

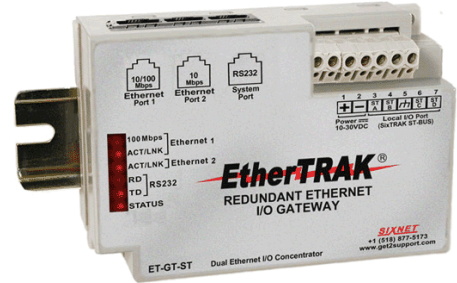

## USER MANUAL

# *EtherTRAK™* Redundant Ethernet I/O Gateway

## Installation and Maintenance



### Contents at a Glance:

<b>Section 1</b>	<b>General Information</b>	<b>3</b>
<b>Section 2</b>	<b>Assembly and Installation</b>	<b>7</b>
<b>Section 3</b>	<b>Power &amp; ST-BUS Wiring</b>	<b>9</b>
<b>Section 4</b>	<b>Communications</b>	<b>12</b>
<b>Section 5</b>	<b>Configuring the ET-GT-ST-3</b>	<b>16</b>
<b>Section 6</b>	<b>Service Information</b>	<b>28</b>

This manual applies to the following products:

**EtherTRAK Redundant Ethernet I/O Gateway (ET-GT-ST-3)**

## **PROTECTED TECHNOLOGY POLICY**

Sixnet protects your investment in Sixnet systems with long-term planned technology and our unique Protected Technology Policy. We will continue to support the specified capabilities of standard Sixnet products for at least five years. We plan each product improvement and new feature to be upward compatible with existing designs and installations. Our goals are to make each new software release bring new power to your Sixnet systems and have every existing feature, applications program and data file continue to work.

We protect your investment even further with a liberal five-year trade-in policy. Exchange standard products for upgraded versions of the same product to take advantage of new features and performance improvements at any time for five years. A prorated trade-in allowance will be given for your existing equipment.

Sixnet protects your long-term productivity with state-of-the-art planned technology and continued support.

## **STATEMENT OF LIMITED WARRANTY**

Sixnet LLC, manufacturer of Sixnet products, warrants to Buyer that products, except software, manufactured by Sixnet will be free from defects in material and workmanship. Sixnet' obligation under this warranty will be limited to repairing or replacing, at Sixnet' option, the defective parts within one year of the date of installation, or within 18 months of the date of shipment from the point of manufacture, whichever is sooner. Products may be returned by Buyer only after permission has been obtained from Sixnet. Buyer will prepay all freight charges to return any products to the repair facility designated by Sixnet.

Sixnet further warrants that any software supplied as part of a product sale, except obsolete products, will be free from non-conformances with Sixnet published specifications for a period of 90 days from the time of delivery. While Sixnet endeavors to improve the features and performance of software associated with its products, no effort on the part of Sixnet to investigate, improve or modify Sixnet software at the request of a customer will obligate Sixnet in any way.

For the convenience of existing customers, Sixnet continues to supply certain products that are classified as obsolete. No warranty on the software features of these products is stated or implied and Sixnet specifically is not obligated to improve the design of these products in any way. Information about the status of any product is available upon request and customers are advised to inquire about the status of older products prior to making a purchase.

This limited warranty does not cover losses or damages which occur in shipment to or from Buyer or due to improper installation, maintenance, misuse, neglect or any cause other than ordinary commercial or industrial applications. In particular, Sixnet makes no warranties whatsoever with respect to implied warranties of merchantability or fitness for any particular purpose. All such warranties are hereby expressly disclaimed. No oral or written information or advice given by Sixnet or Sixnet's representative shall create a warranty or in any way increase the scope of this warranty. This limited warranty is in lieu of all other warranties whether oral or written, expressed or implied. Sixnet's liability shall not exceed the price of the individual units, which are the basis of the claim. In no event shall Sixnet be liable for any loss of profits, loss of use of facilities or equipment, or other indirect, incidental or consequential damages.

These products must not be used to replace proper safety interlocking. No software based device (or other solid state device) should ever be designed to be responsible for the maintenance of consequential equipment or personnel safety. In particular, Sixnet disclaims any responsibility for damages, either direct or consequential, that result from the use of this equipment in any application.

**Note:** All information in this document applies to the EtherTRAK Redundant I/O Gateway; except where otherwise noted. Refer to the Sixnet I/O Tool Kit software online help systems for detailed product specifications and configuration settings.

# Section 1

## Overview

# General Information

This manual will help you install and maintain the EtherTRAK Redundant I/O Gateway. In summary, wiring for power, communications and I/O is connected to the gateway. Then, setup choices are entered using the Sixnet I/O Tool Kit software and the system will be ready to run. Shown below are some typical system configurations.

The ET-GT-ST-3 allows you to build Ethernet I/O stations of as little as 8 I/O channels to as much as 620+ I/O channels. Each ET-GT-ST-3 has two independent Ethernet network ports. This allows you to have redundant Ethernet links to ensure that a simple cable failure will not cause you to lose your I/O. The ET-GT-ST-3 can also be used in conjunction with the SixTRAK IPm Open DCS Controller to provide both redundant network connections, redundant controllers and redundant I/O. With this scheme any single failure of controller, gateway or cable is tolerated.

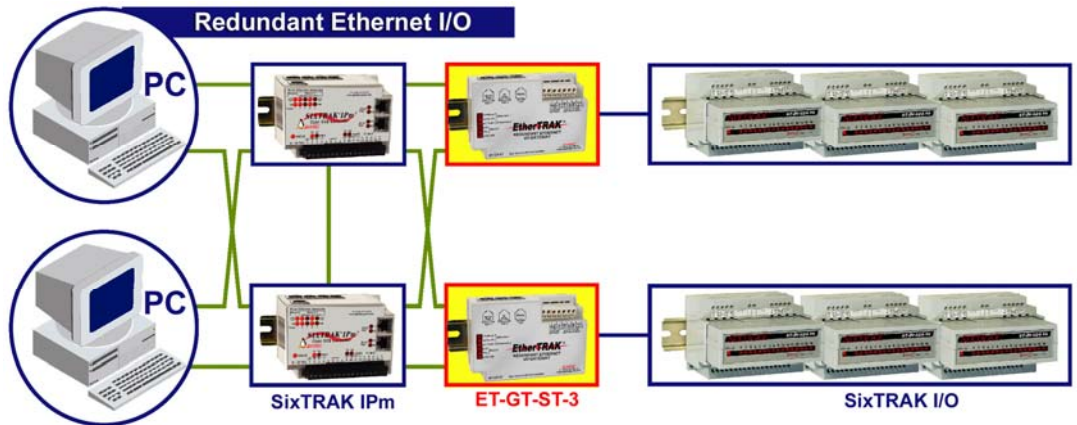

Using the ET-GT-ST-3 for Redundant Ethernet I/O

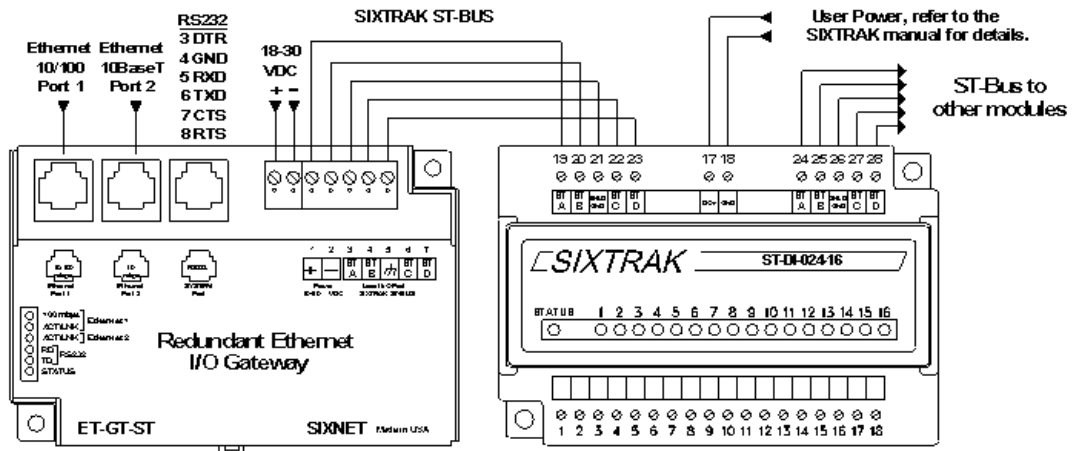

Add up to 20 SixTRAK I/O Modules to an ET-GT-ST-3

## General Specifications

These general specifications apply to the ET-GT-ST-3. More detailed product specifications may be found in the online help system of the Sixnet I/O Toolkit configuration utility.

Required Power	18-30 VDC (I/O Gateway with SixTRAK modules rated for 18-30 VDC); 10-30 VDC (I/O Gateway with newer SixTRAK modules labeled for 10-30 VDC power)
Ethernet port 1	100BaseTx (100 Mbps); Auto-detecting Speed; RJ45
Ethernet port 2	10BaseT (10 Mbps); RJ45
Ethernet Isolation	1500 Volts RMS (for 1 minute)
Operating Temp.	-40 to 70 °C (storage: -40 to 85 °C)
Humidity	5 to 95% (non-condensing)
Protocols	Modbus/TCP, Modbus/UDP, & Sixnet Universal

## Sixnet Software Tools

Sixnet supplies the "mission oriented" tools you need for every step of your project from the initial specification, through startup, and years of trouble free operation. Configuration information flows between Sixnet Windows, saving you time (you don't have to enter data multiple times) and dramatically reducing data entry errors. Refer to the on-line help in the Sixnet I/O Tool Kit for complete details.



### Sixnet I/O Tool Kit

The Sixnet I/O Tool Kit is a configuration, calibration and maintenance tool for Sixnet hardware. Use the I/O Tool Kit to configure I/O features, perform channel-by-channel calibrations in meaningful engineering units, and perform live diagnostics at each station. Refer to the electronic help for details.

Following these steps will make installation and start-up easier.

(Also see Section 5 for more details.)

### ① Mount the Hardware

If you purchased a TrakPak packaged system, the complete enclosure is ready for installation on any flat surface. If you purchased individual components, refer to the following sections of this or the appropriate user manuals for information on installing them into an enclosure.

### ② Install ST-BUS or Communication Wiring to I/O Modules

Make ST-BUS wiring connections to any SixTRAK I/O modules. Refer to a following section for ST-BUS wiring guidelines. Make the necessary communication connections to any EtherTRAK I/O modules. If you have a TrakPak packaged system, all these connections have already been done for you.

### ③ Connect Power and I/O Wiring to the Modules

Connect AC power to the Sixnet or user supplied power supply. Make DC power connections from the power supply to the Sixnet components. Make field wiring connections to the Sixnet I/O modules and any peripheral equipment. Refer to the appropriate user manuals for I/O connection details.

### ④ Install Communication Cabling

Install the appropriate Ethernet and/or RS232 cabling between the Sixnet equipment and to your PC.

Fabricate and install an RS232 cable as needed to connect to other devices. If you are using Ethernet units, install the correct cabling and peripherals. Refer to the documentation for your Ethernet communication devices for details.

### ⑤ Apply Power

Power up the Sixnet components and related peripherals. Observe the status LED on each unit. Typically a solid ON indicates proper operation. A blinking LED may indicate that the unit needs to be configured. Refer to the appropriate Sixnet user manual for details.

### ⑥ Configure Using the Sixnet I/O Tool Kit

Refer to the steps on the next page to create a hardware configuration for each Sixnet station. Refer to the on-line help in the I/O Tool Kit for details.

### ⑦ Test the Hardware

Use the Test I/O window in the I/O Tool Kit program to verify proper I/O operation of all Sixnet stations. Refer to the I/O Tool Kit on-line help system.

### ⑧ Configure Your PC Software to Communicate with the Sixnet station(s)

Refer to the documentation for your software.

### ⑨ If You Have Difficulty

If you experience startup trouble, refer to a following page in this document for some troubleshooting tips or go to [www.sixnet.com](http://www.sixnet.com). If you still need assistance then please contact Sixnet.

## Using Sixnet Windows Software



Below is a quick overview of using the Sixnet I/O Tool Kit. It is supplied on the Sixnet CD and registering for Level 1 (basic features) is free.

**Note:** An expanded version of this page has been provided as on-line help. To access it, click on the Getting Started icon in the I/O Tool Kit online help.

**Basic Configuration:** Run the Sixnet I/O Tool Kit program and create your panel layouts. Then configure operating parameters for each Sixnet component, including channel tag names. Link the SixTRAK I/O modules (if any) and load your configuration to the controller or RTU. Assign virtual I/O modules and I/O transfers for any EtherTRAK modules you wish to have the controller poll. Save this information to a project file. Using the Test I/O function, verify that you can read and write all your I/O.

**Note:** Set tag name restrictions in the Sixnet I/O Tool Kit program before creating tag names to ensure compatibility when exporting them for usage in other Windows applications.

Your Sixnet components are now ready to run. If you will be running a Windows application that requires an I/O driver, then continue with the following steps.



**Exporting I/O Definitions:** (optional) Some Windows applications, such as ISaGRAF, Citect and Intellution FIX, can import Sixnet tag names. If your Windows application supports this feature, run the Sixnet I/O Tool Kit and open your project file. Export your tag names to a file using the appropriate format.

**Note:** If you are exporting tag names for ISaGRAF, Citect or Intellution, you must create, or already have, a project to export tag data into.

## Section 2

## Assembly and Installation

### Panel Assembly

Most Sixnet components snap onto DIN rail strips fastened to a subpanel. Figure 2-1 shows a sample panel with DIN rail strips and wire duct attached. Recommended DIN rail spacing is 8 inches. This spacing allows room for wire duct to be installed without obstructing field wiring installation.

The Sixnet components are typically installed against one another, but space may be left between modules to accommodate other DIN rail mounted components such as terminal blocks and fuse holders. End clamps are recommended to restrict side-to-side movement. Figure 2-2 shows the physical dimensions of the units covered by this manual.

Sixnet components can be installed in any orientation and order on your panel.

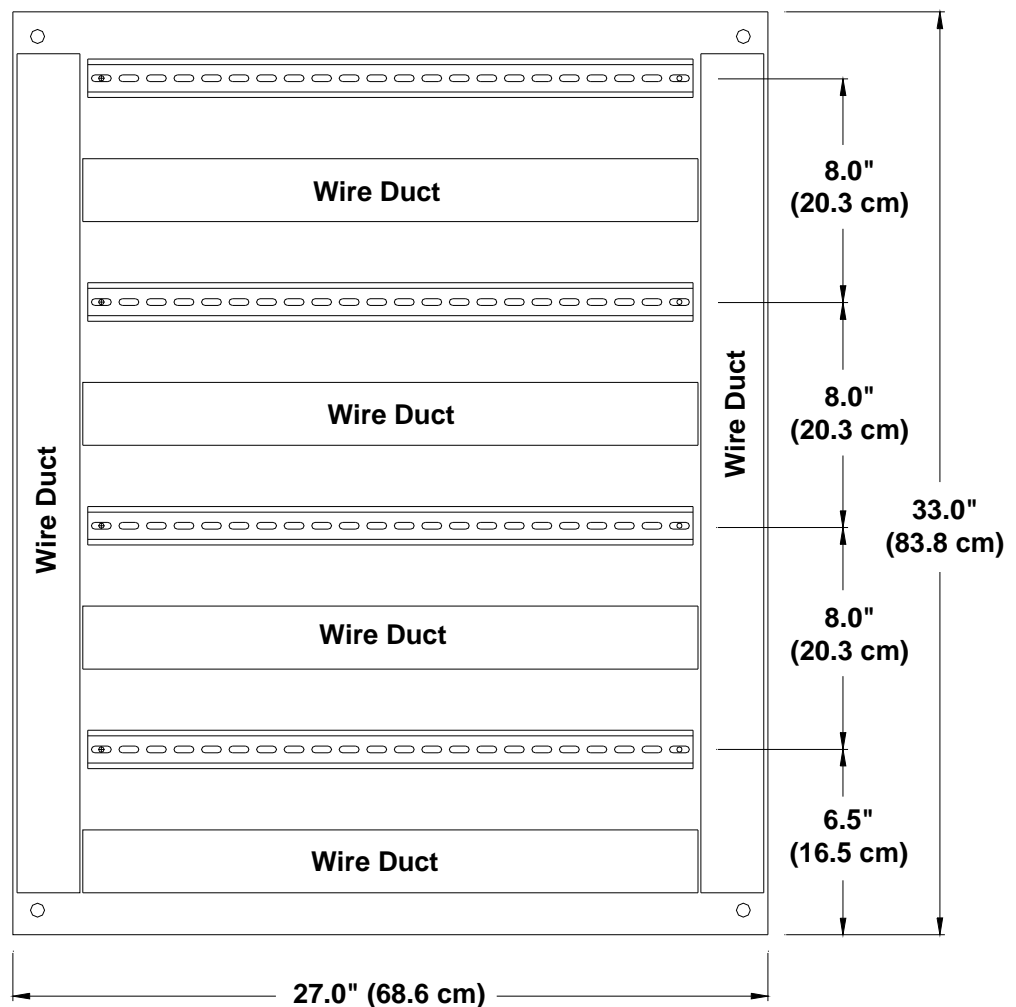

Sample Layout For a 36" x 30" Enclosure  
(Figure 2-1)

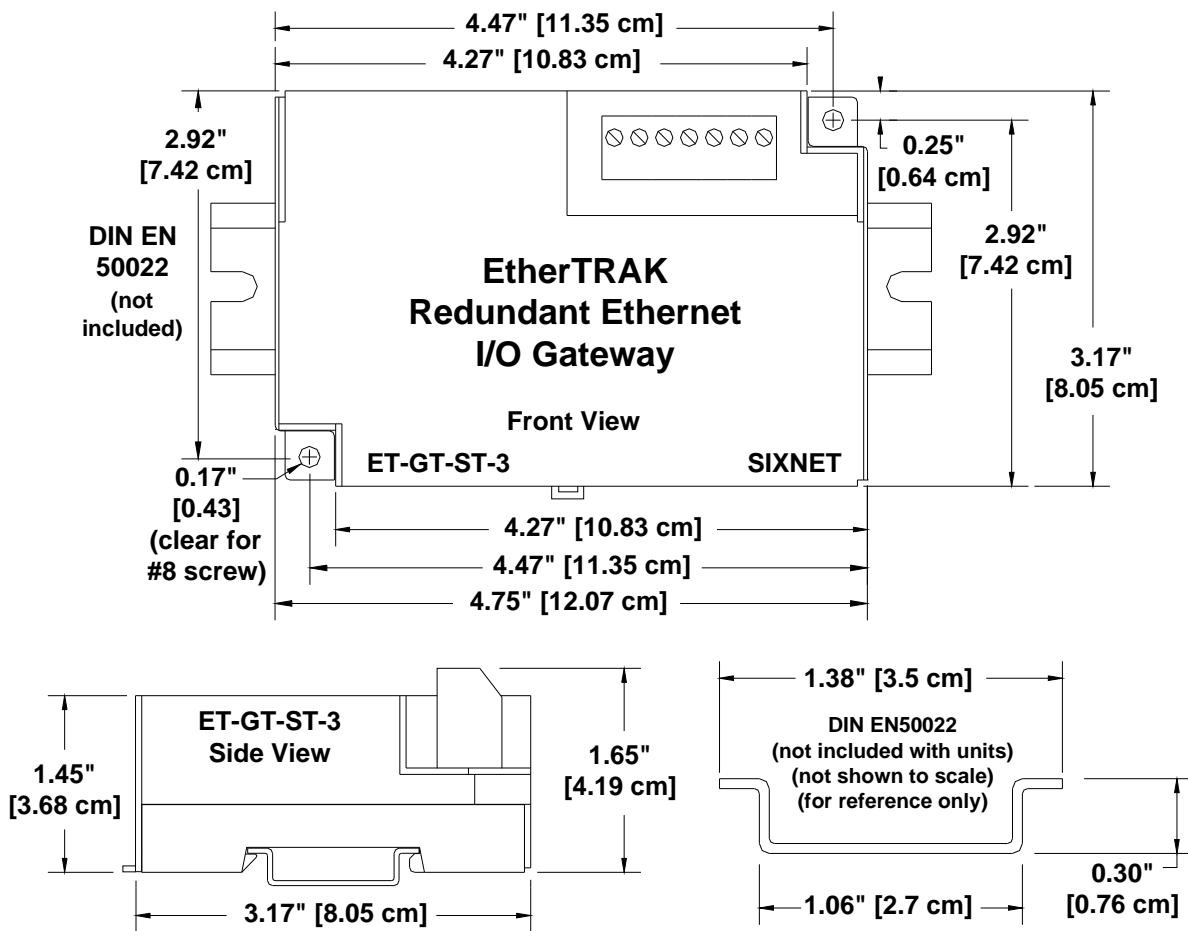

**ET-GT-ST-3 Dimensions  
(Figure 2-2)**





**Current Requirements**

To calculate the current requirements, add the wattage required for the ET-GT-ST-3 and Sixnet modules in use. Then divide the total wattage by the DC power source voltage. Then add any current needed for 4-20 mA user instrumentation loops.

**ST-Bus Wiring Guidelines**

ST-Bus wiring connects the SixTRAK I/O modules to the EtherTRAK Redundant I/O Gateway. Refer to the SixTRAK I/O User Manual for complete ST-Bus wiring guidelines and instructions.

**ST-Bus Capability**

Max. modules connected directly to EtherTRAK Redundant I/O Gateway .....20 (any mix)  
 Required cable type ..... Any with 2 individually shielded pairs, 22AWG min.  
 Recommended cables ..... Alpha 2466C, Belden 8723, Carol C1352  
 Max. cabling off each EtherTRAK Redundant I/O Gateway .....50 ft. (16M)

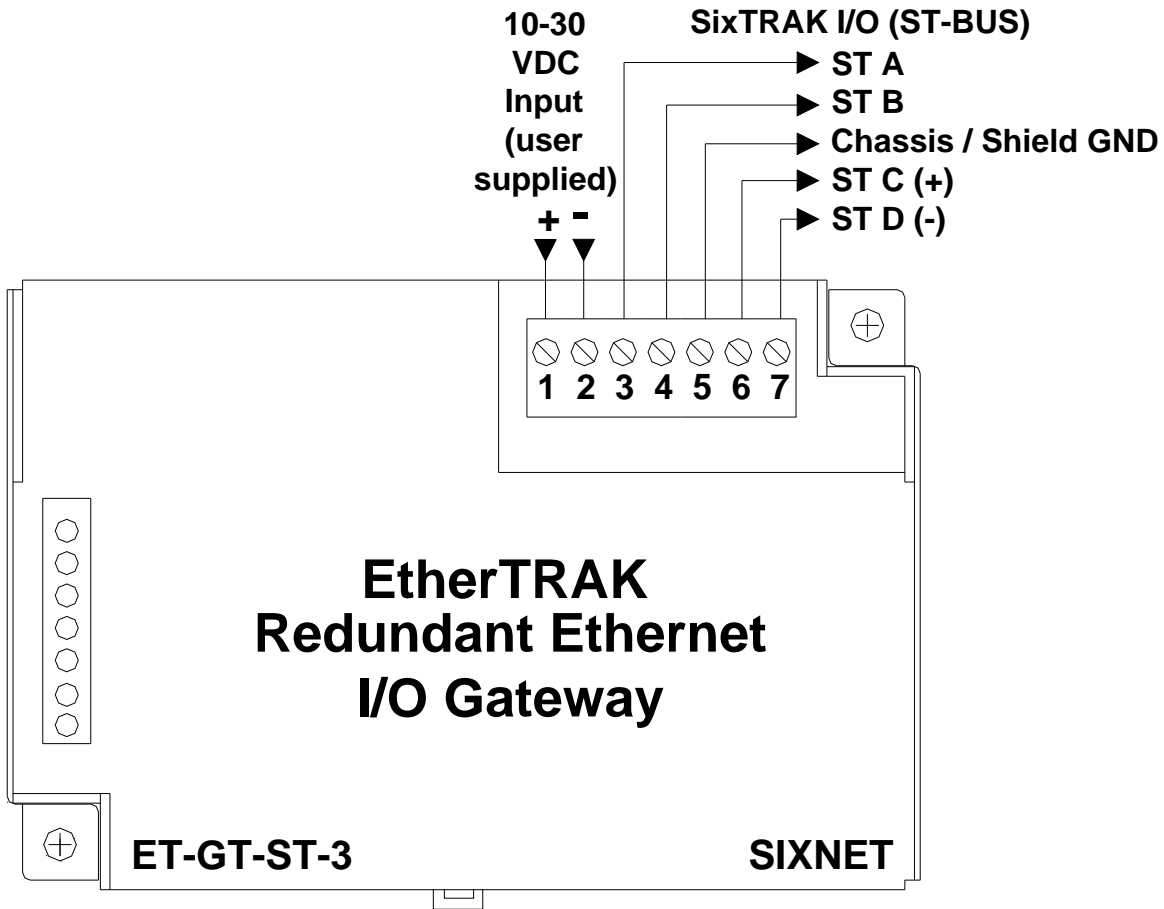

**ET-GT-ST-3 Power and ST-BUS Connections (Figure 3-3)**

**Screw Torque**

All the screw terminals on the base should be tightened to a maximum of 3.48 in-lbs.

## Section 4

## Communications

### Communication Ports

#### RJ45 RS232 Port (ET-GT-ST-3)

The EtherTRAK Redundant Ethernet I/O gateway has the following communication ports and connectors.

EtherTRAK Product	Ethernet 1 Port Style	Ethernet 2 Port Style	RS232 Port Style	SixTRAK ST-BUS
ET-GT-ST-3	RJ45	RJ45	RJ45	Screws

For PC connections there are two choices:

1. Connect a straight-through Ethernet cable between the Sixnet RJ45 port and the prewired RJ45 to DB9 female adapter (part number: RJ45-DB9F-IPM).
2. Insert the colored wires of the unwired RJ45 to DB9 **female** adapter into the appropriate sockets of the DB9 female connector according to the second table below. Plug the adapter's female DB9 connector onto your PC.

The RJ45 serial port connector bodies on Sixnet products are metallic and are connected to the Chassis GND terminal. Therefore, shielded cables may be used to provide further protection. To prevent ground loops, the cable shield should be tied to the metal connector body at one end of the cable only.

**Note:** The Sixnet RJ45 port pinouts are EIA/TIA-561 compliant.

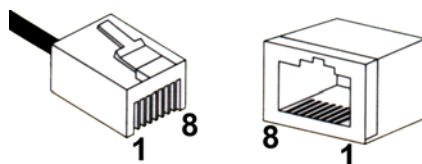

**RJ45 Pin Locations  
(for RS232 or Ethernet)**

Typical PC Adapter Wiring:

<b>RJ45F to DB9F</b>		
<b>RJ45F Pin #, Signal Name</b>	<b>Adapter wire color</b>	<b>DB9 Female Connector Pin #, Signal Name</b>
1 RI/DSR in	Blue	4 DTR out
2 DCD in	Orange	N/C
3 DTR out	Black	6 DSR in
4 GND	Red	5 GND
5 RXD in	Green	3 TXD out
6 TXD out	Yellow	2 RXD in
7 CTS in	Brown	7 RTS out
8 RTS out	White	8 CTS in

#### Ethernet Port 1 (Primary)

This Ethernet port is 10/100BaseTx auto-detecting and auto-mdi/mdix-crossover. This means it will auto-detect the speed, and work with either a straight-thru or cross-wired Ethernet cable. A standard shielded RJ45 connector is provided. See the figures below for the pin-outs. This port has a fixed unique MAC address. The IP address can be set with the Sixnet I/O Tool Kit software. Refer to the on-line help for details.

**Ethernet Port 2  
(Backup)**

This Ethernet port is 10BaseT. A standard shielded RJ45 connector is provided. See the figures below for the pin-outs. This port has a fixed unique MAC address. The IP address can be set with the Sixnet I/O Tool Kit software. Refer to the on-line help for details.

**Note:** The first and second Ethernet ports act independently from each other. Refer to the Sixnet Electronic Help system for more details and usage tips.

**Ethernet Port  
Connections**

See figure 4-1 for Ethernet port pin-outs. Each port has a fixed unique MAC address. The IP addresses can be set with the Sixnet I/O Tool Kit software. Refer to the on-line help for details.

Use data-quality (not voice-quality) twisted pair cable rated category 5 with standard RJ45 connectors. For best performance use shielded cable. Please note that these cables are available as straight-thru or cross-over wired. Either type can be used.

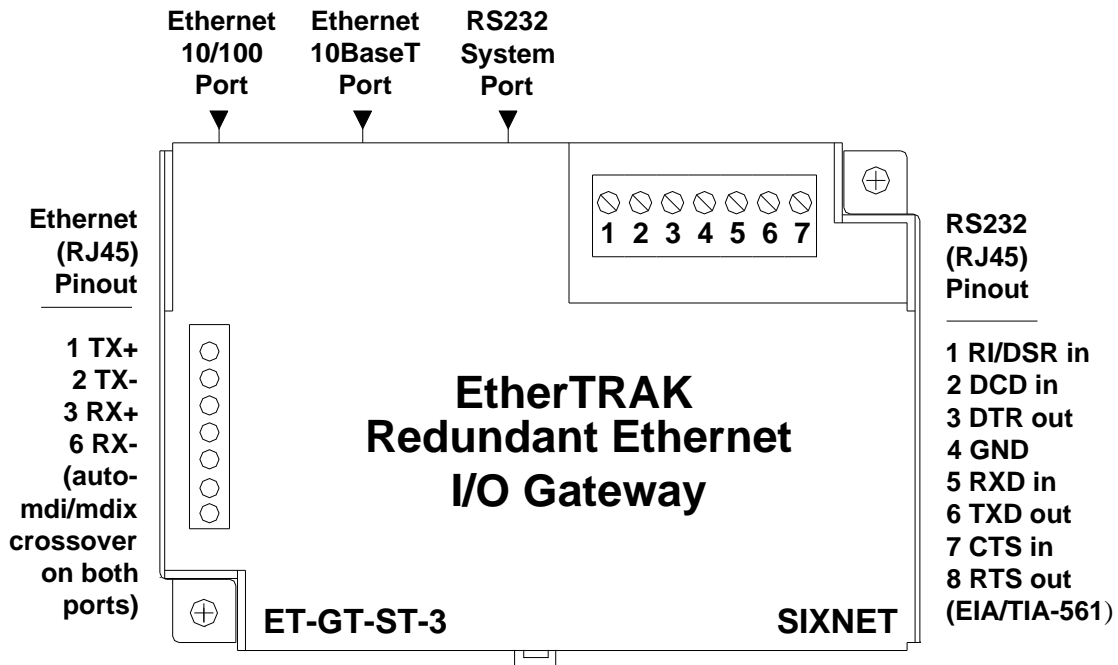

**EtherTRAK Redundant I/O Gateway  
Communication Connections  
(Figure 4-1)**

## Section 5

# Configuring the ET-GT-ST-3

### RS232 Wiring

Connect the RS232 port of the ET-GT-ST-3 to your PC as prescribed in a previous section of this manual.

### Sixnet I/O Tool Kit

The ET-GT-ST-3 is configured using the Sixnet I/O Tool Kit software. Configuration parameters are written over Ethernet or RS232 into permanent memory in the unit. Refer to the Sixnet I/O Tool Kit help for details. The basic steps are:

1. Connect SixTRAK I/O modules and DC power to the unit as prescribed in a previous section of this manual.
2. Connect the unit to your Ethernet network via an Ethernet switch or directly to your PC. Make sure the LNK LED on the unit comes on solid (not blinking).
3. Run the Sixnet I/O Tool Kit, add an ET-GT-ST-3 station and define the parameters for the unit. Be sure to:
  - Choose an IP address that is appropriate for your network. See the help file for details.
  - Enter in the serial number that is printed on a label on the unit.
  - Choose a station (slave) number for the unit that is unique.
4. Once you've completed the wizard, save your project file. Go to the Device menu and choose Serial Port for the communication device. Then go to the Operations menu and select Load. This should set the IP address in the module and then load down your other parameters.
5. Go to the Device menu and choose Ethernet for the communication device. Then go to the Operations menu and select Verify. If this Verify fails for some reason, here are some items to check:
  - Make sure the LNK LED is on solid. If it is off or blinking then a typical cause is a bad cable, an incorrect cable, or you are plugged into the wrong port on your hub/switch.
  - Try to "ping" the unit. Ping is a utility that comes with your PC. Start an MSDOS prompt and type "ping" followed by the IP address of the unit and then hit <CR>. For example, "ping 10.1.0.1" (do not type the quotes). If you get an "unknown command" error then you will need to install the TCP/IP Ethernet protocol on your computer. If you get "destination unreachable" then make sure the gateway's IP address is valid with respect to the IP address and subnet mask of your computer. If you get "request timeout" then check all the items above. For more info., refer to the Sixnet I/O Tool Kit help system.
5. Once you establish that you can communicate with the unit from the Sixnet I/O Tool Kit you then should attempt to communicate with your device using your master software.

## Modes of Operation

The ET-GT-ST-3 has the following modes of operation that can be configured with the Sixnet I/O Tool Kit software:

**Slave Mode** – In this mode the unit operates simply as a slave. It responds to read and write messages from a master PC, controller, RTU, or other device. EtherTRAK stations can respond to messages on all their ports at the same time, allowing for multiple master interrogations. Each serial port can be set for a different protocol (Sixnet or Modbus). Each port can also be configured for slave, master, or Sixnet passthru mode. The two Ethernet ports will respond to Sixnet or Modbus protocol automatically. No protocol configuration is necessary.

**Master Mode** – The ET-GT-ST-3 can act as a Sixnet or Modbus protocol master over its Ethernet or Serial ports. Just configure the port as a Modbus or Sixnet Master and then define I/O Transfers to your slave stations. Refer to the I/O Tool Kit on-line help for details on configuring I/O Transfers.

**Master to Master Mode** – This advanced mode allows two master devices to use the ET-GT-ST-3 to exchange I/O data. In this mode one port is configured for Slave operation and must be connected to a Modbus or Sixnet master device. This device then can write/read I/O data to/from the internal registers of the gateway. Another master device can then do the same on one of the other ports. With this scheme the two ports can be using different protocols. The ET-GT-ST-3 has thousands of I/O registers available for relaying data.

**Passthru Mode** – The ET-GT-ST-3 can be configured for Sixnet Passthru operation. When so, it must be connected to a Sixnet slave device. The Ethernet port must be connected to a master device (via a switch or hub) such as a PC, PLC, or Sixnet controller/RTU. When the gateway receives a message on the Ethernet port from the master device it will look at the station number in the Sixnet message (embedded in a TCP or UDP packet). If the number matches its own then it will respond directly to the message. If the number is anything else then it will pass the message out the other port.

## Section 6

## Maintenance Information

### Local Diagnostics

Local diagnostics can be performed through any available port while the unit is responding to messages from the other port. Diagnostic software, such as the Sixnet I/O Tool Kit, can be used to display the status of the I/O registers. Refer to the software's on-line help for details.

### Status LED

The "Status" LED on the unit indicates its operational status:

**ON**

The unit is operating properly.

**OFF**

There is no power to the controller or service is required. Contact Sixnet technical support.

**FAST BLINK**

This may occur when the unit is being reset, or firmware is to be downloaded from the I/O Tool Kit software.

**SLOW or PERIODIC BLINK**

This indicates that the internal watchdog has detected a problem. Try clearing the memory and reloading the project from the I/O Tool Kit.

### Memory

The ET-GT-ST-3 has nonvolatile (battery-free) memory for storing configuration data from the I/O Tool Kit utility.

It also has battery-backed memory for storage of I/O registers. The battery is a rechargeable lithium cell that is kept fresh by the power circuitry in the unit. The memory retention period for an unpowered unit is at least 6-months at room temperature. The retention time will be shorter at higher temperatures. The life expectancy of the lithium battery is approximately 10 years or more.

### Product Support

To obtain support for Sixnet products, call Sixnet and ask for Applications Engineering. Our phone numbers are:

Phone: 1.518.877-5173

Fax: 1.518.877-8346

E-mail: [support@sixnet.com](mailto:support@sixnet.com)

Visit us on the Web: [www.sixnet.com](http://www.sixnet.com)

Our mailing address:

**Sixnet Technology Park**

331 Ushers Road

Ballston Lake, NY 12019

## Section 11

## Service Information

### Service Information

We sincerely hope that you never experience a problem with any Sixnet product. If you do need service, call Sixnet at (518) 877-5173 and ask for Applications Engineering. A trained specialist will help you to quickly determine the source of the problem. Many problems are easily resolved with a single phone call. If it is necessary to return a unit to us, an RMA (Return Material Authorization) number will be given to you.

Sixnet tracks the flow of returned material with our RMA system to ensure speedy service. You must include this RMA number on the outside of the box so that your return can be processed immediately.

The applications engineer you are speaking with will fill out an RMA request for you. If the unit has a serial number, we will not need detailed financial information. Otherwise, be sure to have your original purchase order number and date purchased available.

We suggest that you give us a repair purchase order number in case the repair is not covered under our warranty. You will not be billed if the repair is covered under warranty.

Please supply us with as many details about the problem as you can. The information you supply will be written on the RMA form and supplied to the repair department before your unit arrives. This helps us to provide you with the best service, in the fastest manner. Normally, repairs are completed in two days. Sometimes difficult problems take a little longer to solve.

If you need a quicker turnaround, ship the unit to us by air freight. We give priority service to equipment that arrives by overnight delivery. Many repairs received by mid-morning (typical overnight delivery) can be finished the same day and returned immediately.

We apologize for any inconvenience that the need for repair may cause you. We hope that our rapid service meets your needs. If you have any suggestions to help us improve our service, please give us a call. We appreciate your ideas and will respond to them.

For Your Convenience:

Please fill in the following and keep this manual with your Sixnet system for future reference:

P.O. #: \_\_\_\_\_ Date Purchased: \_\_\_\_\_

Purchased From: \_\_\_\_\_

### Product Support

To obtain support for Sixnet products, call Sixnet and ask for applications engineering. Our phone numbers are:

Phone: 1.518.877.5173

Fax: 1.518.877.8346

e-mail: support@sixnet.com

Our mailing address:

**Sixnet Technology Park**

331 Ushers Road

Ballston Lake, NY 12019