

The University Bath Hoist & University Transporter

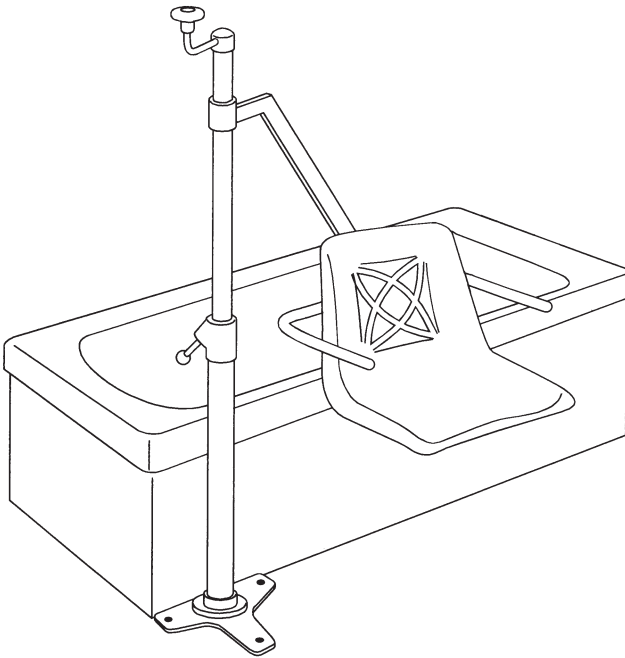

University Electric Bath Hoist

Contents

Introduction	3
Side and End fitting illustration	4
Assembly and installation instructions	5
University Electric Bath Hoist illustration	6
Fitting dimensions	7
Installation of base plate	9
Wooden floor installations	11
University Bath hoist setting up procedure	12
Operating instructions	14
Safety precautions	16
Charging instructions	17
Maintenance schedule	19
Daily check list	19
Schedule maintenance, inspection and test	20
Technical specification	21
Servicing, repairs, inspections and testing	22
Trouble shooting list	23

Every hoist is assembled, fully inspected and load tested in the factory before being disassembled for transportation. A certificate of testing is supplied with each hoist. It is important to install the hoist according to the instructions and guidelines provided in this manual. A number of documents are supplied with each hoist:

- **Test Certificate**
- **User Manual**
- **Dealer Guarantee Card**
- **Customer Satisfaction Card**

The TEST CERTIFICATE is an important document and should be kept in a safe place. It will be required for insurance and LOLER records. The certificate is valid for six months. The University Hoist Company recommend the bath hoist is thoroughly examined and tested every six months by a competent person.

These recommendations are in line with the requirements of No2307 Health and Safety: The Lifting Operations and Lifting Equipment Regulations 1998 (LOLER). Servicing and periodic examination and test can be carried out by your supplier.

Application

The University Bath Hoist and Transporter are suitable for Category C – Bath. The University Bath Hoist and Transporter are suitable for patients in the SITTING Position.

The CE Mark

The University Bath Hoist and Transporter carries the CE mark and complies with the following EC directives:

Medical Device Directive (93/42/EEC)

EMC Directive (89/336/EEC) (Electric's only)

Low Voltage Directive (73/23/EEC) (Electric's only)

1. Left hand side fit
2. Right hand side fit
3. End fit

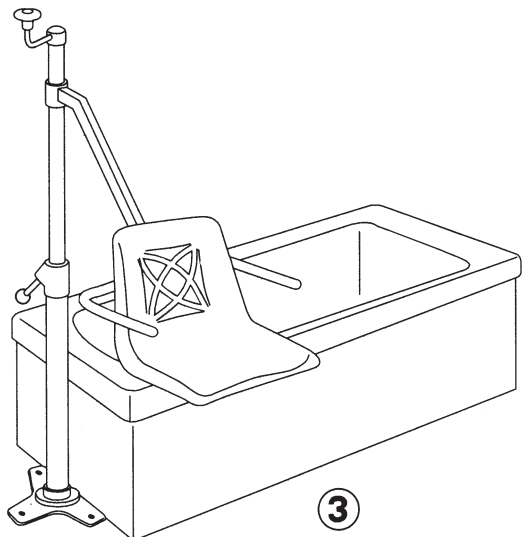
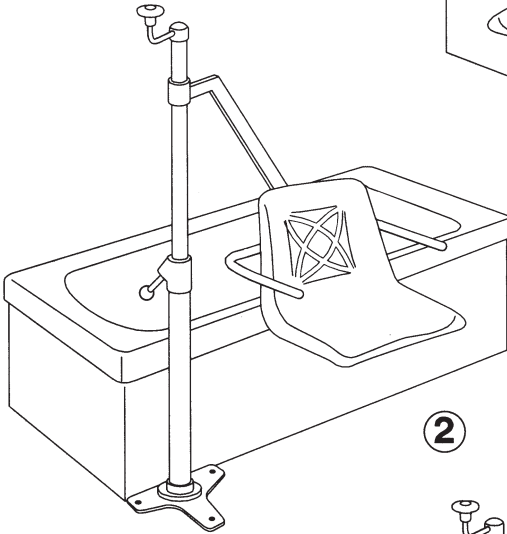
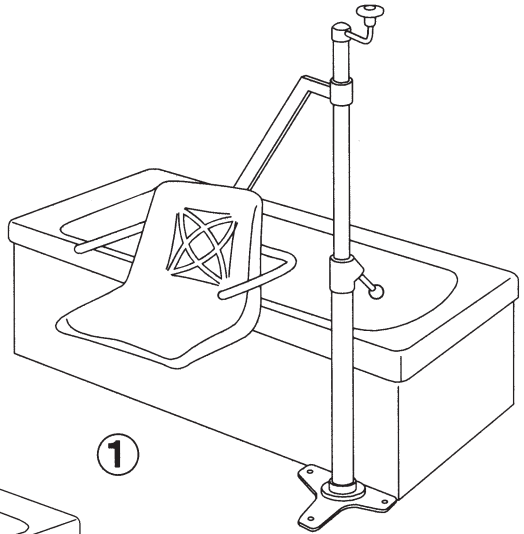

These Instructions apply to the following Models:

- University Bath Hoist
- University Transporter
- University Electric Bath Hoist
- University Electric Transporter

Bathroom Floor Construction

University bath hoists are supplied in two different fixing configurations –

1. For fixing to concrete floors
2. For fixing to wooden floors.

The type of floor fixing must be specified at time of ordering.

Positioning of Bath hoist

University Bath Hoists can be fitted in two positions relative to the bath. The most popular is where the hoist is fitted at the side of the bath and the end fit where the mast is fitted on the centre line of the bath at one end (see illustration page 4), usually the end furthest from the taps. The end fit requires a different arm arrangement to the side fit and must be specified at the time of ordering.

Assembly of University Bath Hoist & Transporter

1. Remove all the parts from the packing cartons, taking care to protect the finish from damage.

SAFETY NOTE:

Some of the parts are heavy and will need to be lifted with care. You may need assistance with the heavier assemblies and components.

2. Before starting assembly establish the seat position required. The drawing on page 4 will help clarify whether a left, right or end fit arm is required.
3. Having established the seat position, assemble the seat and safety arms to the seat support arm. These components are fixed together with two stainless steel nuts and bolts. Fully tighten the nuts and bolts

SEAT POSITIONING

When fitted, the hoist seat should be located on the centreline of the bath and sufficiently forward of the back slope to enable the seat to lower to within 50 mm of the bath bottom. The distance between the mast and the seat is fixed, there is no adjustment. It is therefore very important to establish the exact position of the mast in relation to the bath. Baths vary greatly in depth, width, length and shape. Please follow the instructions carefully to ensure a successful installation.

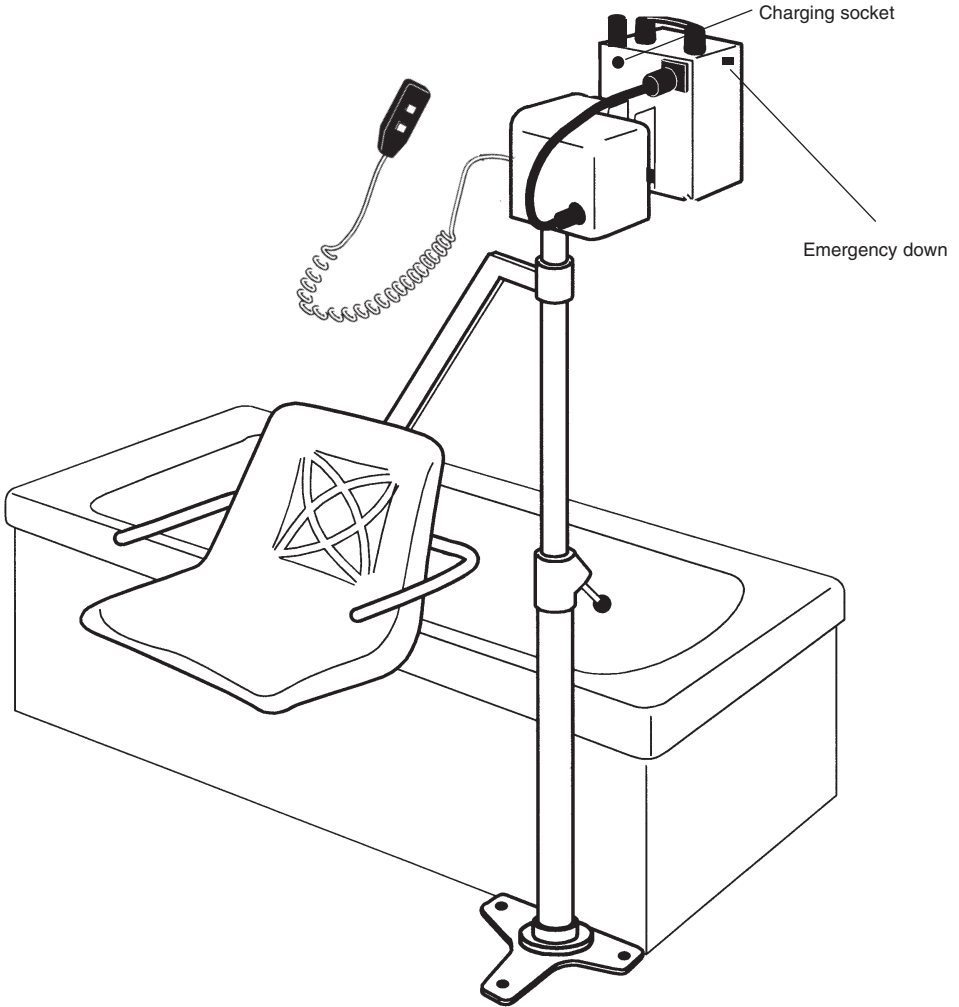

University Electric Bath Hoist

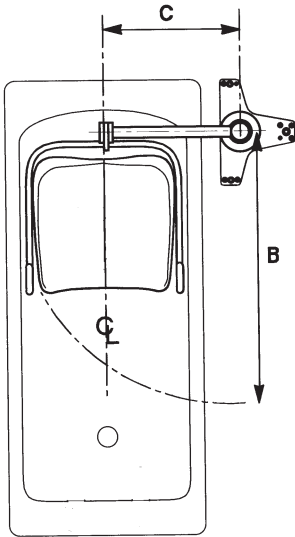

SIDE FITTING

BATH HOIST	COMMODE	TRANSPORTER
B = 850mm	810mm	910mm
C = 430mm	430mm	430mm

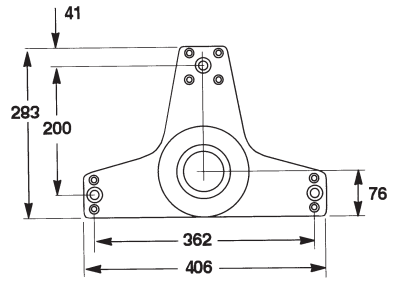

**UNIVERSAL BASE PLATE
PRINCIPLE DIMENSIONS**

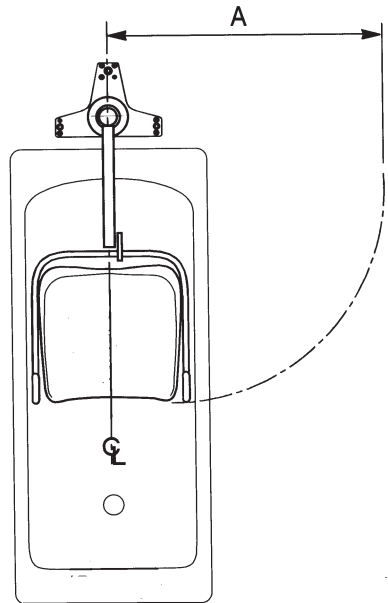

END FITTING

BATH HOIST	COMMODE	TRANSPORTER
A = 865mm	915mm	890mm

IMPORTANT NOTE:

The hoist seat may damage the sides or back of the bath if it is not correctly positioned

1. Lay the base plate on the floor in roughly the final position, either at the side of the bath or at the end. Fit the mast over the four fixing studs on the base plate. Tighten down the nuts provided onto the studs. It is not necessary to fully tighten at this stage.
2. Connect the seat and arm to the hoist column. The open square end of the seat arm fits over the square shaft on the hoist column. Make sure the safety screw is in place and securing the seat arm.

WARNING

The hoist will not stand on an unsecured base plate. The hoist will need supporting at all times during this operation.

3. Next, position the seat in the bath. Move the whole assembly until the seat is in the correct position. This is with the centreline of the seat on the centre line of the bath with clearance both sides and as far back as the slope of the bath will allow. Make sure there is clearance under the seat and make allowance for some downward movement when the seat is loaded. This will avoid damage to the surface of the bath when the seat is loaded.
4. When you are satisfied the seat is in the correct position, mark the floor where the base plate fixing holes are to go. Remove the base plate from the column, this will make it easier to handle while fixing.

WARNING

Check the area of the floor for hidden services – underfloor heating elements, power cables, water pipes etc. before drilling any holes

IMPORTANT NOTE

Take into consideration the turning radius of the seat and make allowance for clearance of the client's knees from radiators, walls, sinks, toilet pans etc. A minimum requirement is a metre from the centre of the column.

CONCRETE FLOORS: Secure fixing of the base plate is essential to the safety of the client. Make sure the concrete floor is sound and at least 120 – 150mm thick. A thin layer of top of screed is acceptable, as long as the expanding section of the fixing bolts are in sound concrete. If you have any doubt as to the suitability of the floor, consult a professional. Drill three 16mm diameter x 125mm deep holes in the positions marked out from the base plate. Locate the base plate and insert the expanding bolts.

WARNING

The type of expanding bolts, which supplied with the hoist, are designed to be fitted fully assembled, **DO NOT** take them apart. Tighten the bolts fully with the Allen key supplied.

IMPORTANT NOTE

Not all concrete floors are suitable for expanding bolts. Floors constructed from pre-cast concrete beams with block infill present problems and it may not be possible to install the hoist. If your floor is this type of construction you should consult an architect before attempting installation

WOODEN FLOORS: Secure fixing of the base plate is essential to the safety of the client. Make sure the floor is of sound construction and is not affect by water spillage, rot or insect damage. If in any doubt as to the suitability of your floor, consult a professional.

There are many forms of wooden floor construction. The following information is offered only as guidelines for your builder or carpenter, whose professionalism will be the important factor in the secure and safe installation of the hoist. Not all wooden floors are constructed in such a way to allow for hoist mounting without extensive strengthening.

For the most common floorboard construction, an under floor bracing kit is supplied as a standard pack. It may not suit all applications. See the illustration on page 11.

If the location of one or more of the base plate fixing holes coincide with a joist, then a heavy wood screw or coach bolt can be used in conjunction with the bracing kit.

Installation of the base plate

Additional holes in the base plate allow for extra location points on wood floors. Floorboards in the immediate area of the base plate should be secured to the joists with heavy wood screws

Chipboard and similar lightweight floors will need to be reinforced locally. The advice of a professional should be sought to establish the amount of reinforcing necessary.

Strengthening sections alongside and between existing joists can be used as reinforcing.

Floors can be strengthened by additional local fixings to the existing joists. Alternatively a heavy marine plywood can be inset into the floor and secured to existing joists.

If in doubt, seek professional advice.

A pair of steel bars are provided for the installation of the Bath Hoist to wooden floors. The bars have three tapped fixing holes and three countersunk steel screws are supplied for fixing. The bars should be used as follows:

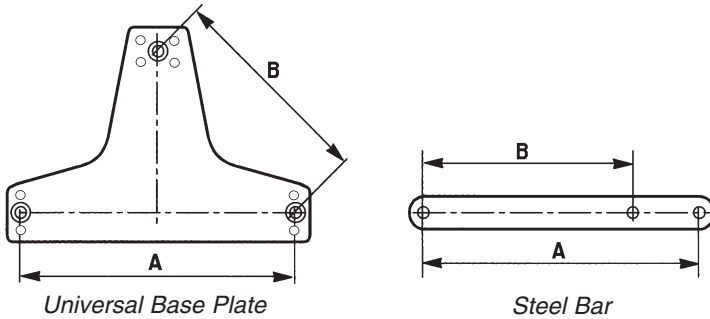

All three holes in the base plate should be used, with one bar spanning either 'A' or 'B' and the other bar bolted through the third hole. Ideally each bar should span as many floorboards as possible (usually three). Whether a bar will span either 'A' or 'B' will be depend on direction and position of the joists in the area chosen for the Bath Hoist.

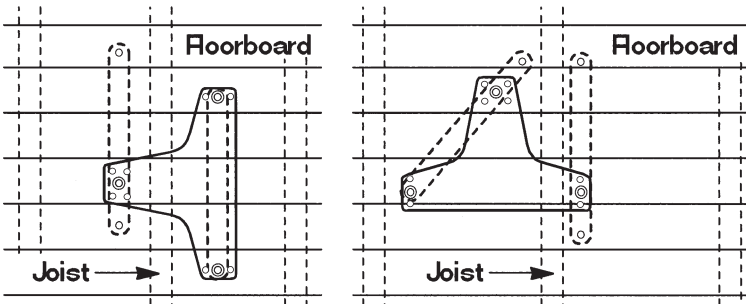

Access to the underside of the floor is normally achieved by removing a section of floorboard adjacent to the fixing area. This section need only be large enough to allow the insertion and positioning of the bars. All floorboards in the area around the base plate should be fixed down firmly to the existing joists with 4" (100mm) countersunk wood screws.

IMPORTANT NOTE

The installation of the hoist should always be tested for safety and security according to the recommendations on page 12

Testing of the installation

With the base plate firmly installed, place the mast back onto the base plate studs and fully tighten down the four nuts cover with plastic nut covers.

IMPORTANT:

It is strongly recommended the installation of the base plate is load tested before the Bath Hoist is put into use.

Following the recommendation in BS EN ISO 10535 1998: Hoists for the transfer of disabled persons (Annex A para. A1) the installed hoist should be load tested one lifting cycle with the safe working load. In the case of the Bath Hoist and Transporter the test load is 130 kg. This load is applied to the centre of the seat. DO NOT ignore this test. If in doubt contact your supplier.

Setting up

The Bath Hoist and Transporter models have setting up procedures that must be followed to ensure the hoist operates safely and causes no damage to the bath or fittings.

SEAT LOCKING SYSTEM:

The seat can be locked in four positions, 90° apart. Locking, and unlocking, is achieved by operating by a lever located on the column. Fully UP, the lever will unlock the seat and allow 360° rotation. Fully DOWN, the seat will lock in one of the four positions. If the lever is pushed down in-between the fixed positions it will engage automatically when the next fixed locking position is encountered.

WARNING

DO NOT use this automatic engagement to stop the movement of a loaded seat. If latch is used repeatedly to stop a moving, loaded seat, the latch will suffer damage and replacement will be required.

SETTING THE LOCKED POSITIONS RELATIVE TO THE BATH: Check the position of the seat in relation to the bath. If the seat is not in line with the centreline of the bath it's position can be adjusted as follows:

Slacken the seat support clamp by loosening the Allen headed screw on the side of the clamp. This will allow the clamp, seat and seat arm to rotate. Push the locking lever fully down and make sure it has engaged in one of the fixed positions. Swing the seat until it is in line with the centre line of the bath. Lightly tighten the Allen headed screw on the seat support clamp. Release the seat lock and rotate the seat through 90°. This will place the seat in the normal start position at the side of the bath. If this is the only adjustment required FULLY tighten the Allen headed screw. If height adjustment is required leave the Allen screw lightly tightened and go on to the next section.

TRANSPORTER MODEL: The Transporter design differs from the Bath Hoist and requires additional instructions.

The Transporter chair is made up of two assemblies, a wheeled base and a seat with armrests. The halves of the complete chair are connected with a simple latch located at the rear of the seat. The chair is attached to the Bath Hoist as follows:

1. The chair support arm of the hoist has a hook and latch device similar to the one connecting the seat to the wheeled base. The support arm hook must be engaged with the cross bar at the top of the seat. An automatic latch will engage to prevent accidental disengagement.
2. The seat can now be lifted off the wheeled base by operating the seat latch, which holds the seat to the wheeled base, and raising the support arm of the lift with the handcontrol or winding handle. The seat will be elevated with the support arm and the wheeled base will remain behind.
3. To reconnect the seat to the base, lower the seat using the handcontrol or winding handle back onto the wheeled base with the lower safety latch in approximately the right position. The seat will lock automatically as it is lowered. When the seat latch is engaged, disengage the latch on the chair support arm and continue to lower. The support arm will drop away from the seat and can be swung away to one side. Check full engagement of the seat latch. The patient can now be transported to another location.

IMPORTANT NOTE:

When the seat is fully secured to the transporter, it is important to ensure the upper safety latch is completely disengaged. Damage to the rear castors will occur if the Bath Hoist continues to be lowered with this latch engaged or partially engaged. The safety locking system has been designed to be very visible and very obvious in operation – double check the latches have engaged or disengaged correctly.

EMERGENCY RAISE: This facility will raise the seat should the lift fail to rise with the handcontrol. It is for emergency use only and should not be used for routine raising. The switch is located on the power unit cover.

Operating the Bath and Transporter Hoist

The University range of bath hoists are designed to be as simple and safe to use as possible. Please follow these simple instructions below, this will help to ensure safe and efficient operation.

MANUAL BATH HOIST - RAISING & LOWERING: On the manual versions of the bath hoist the seat is raised or lowered by the winding handle on the top of the lifting column. Anticlockwise rotation lifts the seat and clockwise lowers the seat. Positive stops are built into the mechanism and limit the amount of travel.

WARNING

DO NOT attempt to force the winding handle beyond the stops as this will damage the mechanism and will lead to expensive repairs.

ELECTRIC BATH HOIST - RAISING & LOWERING The patient seat is raised or lowered by operating the push buttons on the hand control. The hand control is plugged into the control unit on the top of the main column. The buttons are marked with directional arrows. Limits of travel are determined by electronic stops built into the circuitry.

WARNING

Repeated activation of the hand control buttons once the end stops are encountered will damage the control circuitry and shorten working life.

SEAT ROTATION: Release the seat lock by fully lifting the locking lever, the seat is now free to rotate 360°. When the locking lever is fully down, the seat will lock in one of four positions. If the lever is pushed down at an intermediate position it will automatically engage when it encounters the next locking position.

WARNING

DO NOT rely on the automatic engagement of the seat lock to halt the clients rotation. This can cause high loading on the mechanism and will eventually lead to damage and ultimate failure

HEIGHT ADJUSTMENT OF THE SEAT: In normal use the seat will sit lower in the bath than when it is unloaded. It is important, therefore to take this in consideration when setting the seat height. Damage to the bath may occur if the seat is set too low in the bath.

With the seat aligned with the centre line of the bath, slacken the seat clamp again.

Making sure the seat does not rotate out of alignment, slide the clamp up to its maximum position and lightly retighten. Using the winding handle, wind the seat to its lowest position (until the bottom stop is encountered). Slacken the clamp again and carefully slide it down the mast until the bottom of the seat is 30 – 50 mm from the bottom of the bath. Lightly tighten the clamp and recheck the alignment of the seat in the bath. FULLY tighten the clamp Allen screw. The Allen screw must be fully tightened to effect a positive lock.

Baths higher than usual

If the seat hits the bottom of the bath before the end stop is encountered, steps must be taken to avoid damage to the bath. The Bath Hoist and Transporter have been designed to be comparable with a wide range of bath design but the installer may encounter a bath which does not conform to "normal" design.

If the seat "bottoms out" before the end stop on the hoist is encountered, this indicates the bath is elevated higher than normal.

Firstly, check the seat is wound up so its highest position clears the top edge of the bath. Remember a loaded hoist will be lower than an unloaded one, so make sure there is sufficient clearance.

If the seat satisfactorily clears the top edge of the bath then a stop collar can be used to set the lowest position.

If the seat does not clear the top edge of the bath then the hoist must be fitted with a spacer at the bottom of the mast.

Contact Unihoist Ltd. for supply of either the stop collar or the spacer.

Safety precautions

Please read and follow the safety precautions listed below. The operation and use of the University patient hoists is simple and straightforward. Following these few basic safety precautions will make lifting operations easy and trouble free.

- 1 **ALWAYS** plan your lifting operation before commencing.
- 1 **ALWAYS** carry out the DAILY CHECK LIST before using the hoist.
- 1 **ALWAYS** familiarise yourself with the operating controls and safety features of a hoist before lifting a patient.
- 1 **ALWAYS** check the safe working load of the hoist is suitable for the weight of the patient.
- 1 **ALWAYS** carry out lifting operations according to the instructions in the user manual.
- 1 **NEVER** disconnect or bypass a control or safety feature because it seems easier to operate the hoist.
- 1 **NEVER** force an operating or safety control. All controls are easy to use and do not require excessive force to operate. If a control is not working easily there will be a reason. Forcing will only strain or damage the hoist and may compromise safety.
- 1 **DO NOT** charge an electric hoist in a bathroom or shower room.
- 1 **DO NOT** lift a patient unless trained and competent to do so.
- 1 **YOUR** lift is for patient lifting. **DO NOT** use it, or allow it to be used, for any other purpose.

The batteries are located in a power pack and are charged through a socket located on the back face of the pack. This socket also serves as a power supply socket to the hoist. This is a safety feature as it means the hoist cannot be used when charging is taking place. The socket is labelled **POWER/CHARGING POINT**. The battery pack can be removed from the hoist and charged elsewhere or it can be charged while still attached to the hoist. Additional battery packs can be supplied, if required, so that one pack can be on charge at all times.

1. Remove the power supply plug from the **POWER/CHARGING POINT** socket. The plug is removed with a straight pull. **DO NOT** twist the plug in the socket. The battery pack can now be removed from the hoist for charging elsewhere or left in place for charging with the hoist. To remove a battery pack simply pull the battery pack up by the handle on top of the pack and disengage the pack from the locating pins on the mast. Reverse the process for reconnection.
2. Connect the battery charger plug to the **POWER/CHARGING POINT** socket. The plug is indexed and can be fitted only one way. Make sure the red locking ring on the charging plug is in the unlocked position. (Moulded pointer on the locking ring pointing to the "Unlocked" position). Connection is achieved with a straight push and then the locking ring can be twisted to "Lock" position.
3. Plug the charger mains plug into a suitable mains outlet and switch the mains supply **ON**.
4. Charging is fully automatic. The status of the charging is indicated by two LED indicators (see table below). Note: Even if the charger is left plugged in for extended periods it will not allow the batteries to "overcharge".
5. To return the hoist to service, switch OFF the mains supply, twist the locking ring on the charger plug to "Unlocked" and disengage from the **POWER/CHARGING POINT** with a straight pull. **DO NOT** pull on the cable to disengage the plug. The power supply plug can be reconnected with a straight push. **DO NOT** twist the plug in the socket. The lift is now ready for use.

Charger Status	LED Indicators
Bulk charger mode	Yellow – static ON
Battery charged	Green – static ON
Battery reversal detected	Yellow – flashing
High temperature detected	Yellow + Green – flashing simultaneously
Short circuit	Yellow + Green – flashing alternately
Open circuit	Yellow + Green – static simultaneously

Charging instructions for the University Electric Bath Hoist

Charging the battery pack is a simple procedure but it is important to keep the batteries regularly charged. Follow the charging instructions closely. The batteries used for the bath hoist have been selected for their capacity, long life and maintenance free characteristics BUT they do not react well to deep discharge or being left uncharged for long periods. Please pay particular attention to the following points, they will help you avoid problems with discharged batteries.

- ⊙ **KEEP** the batteries fully charged. Place the hoist on charge whenever it is not in use. The charger will not allow the batteries to "overcharge".
- ⊙ **NEVER** run the batteries completely flat. If the audible warning sound, complete the lifting operation in hand and place the lift on charge.
- ⊙ **NEVER** store the hoist for long periods without regular charging throughout the storage period.
- ⊙ **ALWAYS** make sure the mains power to the charger is switched off before connecting or disconnecting the charger to or from the lift.
- ⊙ **NEVER** leave the charger plugged in to the hoist with the mains power off.
- ⊙ **NEVER** disconnect the charger plug by pulling on the cable.

Unihoist Ltd. recommend a six monthly thorough examination and test, carried out by a competent person. We also recommends an annual service. This is in line with the statutory provisions of **1998 No 2307 Health and Safety: The Lifting Operations and Lifting Equipment Regulations 1998**.

Statutory requirements for regular servicing may alter from country to country, please check your national regulations.

Daily checks and a regular service, inspection and test will ensure a hoist is kept in optimum safe working condition. A list of spare parts is available upon request. The **LOAD TEST** and certification should be carried out by a competent person as defined in the LOLER regulations.

Daily Check List

Unihoist Ltd. strongly recommend the following checks are carried out on a daily basis and before using the hoist.

- ⊙ **MAKE** sure the hand control (electric's only) is plugged in firmly and the hoist raises and lowers smoothly.
- ⊙ **MAKE** sure the winding handle on manual hoists operates smoothly and the hoist raises and lowers.
- ⊙ **CONFIRM** the Bath Hoist is not sounding a low battery alarm (electric's only) when the hand control is operated. If the alarm sounds, **DO NOT** use and place the power pack on charge immediately.
- ⊙ **CHECK** the operation of the emergency stop button (electric's only).
- ⊙ **CHECK** the operation of the emergency raise button (electric's only).
- ⊙ **MAKE** sure the seat is free to swing.
- ⊙ **CHECK** the support arm safety screw is in place and tight.
- ⊙ **MAKE** sure the base plate is firmly fixed to the floor.
- ⊙ **MAKE** sure the castors on the Transporter chair are free to rotate and the brakes operate.

Unihoist Ltd. recommend the following tasks are carried out by authorised service dealers only.

FLOOR FIXING: Check the base plate fixing is sound and secure. Follow the test routing as detailed in the test manual. Wooden floors required inspection at more frequent intervals.

MAST TO BASE: Check the four Nyloc nuts securing the mast to the base plate are fully tightened. Check also for signs of grease leakage between the mast and the base plate.

CHAIR SUPPORT CLAMP: Check the chair support clamp is correctly orientated as per the Setting UP instructions. Make sure the seat does not touch the side or bottom of the bath. Check the seat locks in the correct positions.

CHECK the operation of the seat lock.

SUPPORT ARM: Check the support arm has the safety screw in position and tightened. Check the seat is securely attached to the support arm and the fixing nuts and bolts are fully tightened.

SEAT: Check the seat for splits or damage. Check the Bath seat for presence of nine safety plugs fitted to the seat moulding (lifts before December 1998).

CASTORS: Check all castors are free running. Check fixing to the chair legs. Check brakes for correct operation.

HANDCONTROL: Check the up and down switches of the handcontrol. Take the seat to the lowest position and confirm the operation of the bottom stop. Check the seat does not hit the bottom of the bath. Prevent the downward movement of the seat and check the power is switched off automatically.

MOTOR UNIT: The motor should require no maintenance other than checking for correct operation and listening for unusual noise.

BATTERIES: The batteries are housed in the power pack and should not require maintenance other than regular charging as detailed in the charging instructions.

EMERGENCY STOP BUTTON: Check the operation and correct functioning of the emergency stop switch located on the rear of the power pack.

EMERGENCY RAISE BUTTON: Check the operation and correct functioning of the rocker switch located on the motor unit.

SAFETY LATCHES: Check the correct function of the safety latches on the Transporter Chair and the Transporter support arm.

CLEANING: Clean with ordinary soap and water and/or any hard surface disinfectant. Harsh chemical cleaners or abrasives should be avoided as these may damage the surface finish of the hoist.

LOAD TEST: The load test should be carried out in accordance with the manufacturers test procedures. It is strongly recommended the testing is carried out by a competent person as defined in the LOLER regulations.

CERTIFICATION: An authorised service dealer will issue a test certificate after satisfactory completion of the load test. This certificate will be valid for the period

University Bath Hoist & Transporter Technical Specification

Dimension	Model	Manual	Electric
Safe Working Load (SWL)	130kgs	130kgs	
Highest position from base of seat	740mm	715mm	
Lowest position from base of seat	140mm	140mm	
Seat travel		485mm	485mm
Width of seat	Bath Hoist	450mm	450mm
	Commode	360mm	360mm
	Transporter	360mm	360mm
Width between arms	Bath Hoist	395mm	395mm
	Commode	395mm	395mm
	Transporter	430mm	430mm
Depth of seat (front to back)		410mm	410mm
Centres between mast and seat		430mm	430mm
Max. seat turning circle (side fit)	Bath Hoist	850mm	850mm
	Commode	810mm	810mm
	Transporter	840mm	840mm
Max. seat turning circle	Bath Hoist	865mm	865mm
	Commode	815mm	815mm
	Transporter	890mm	890mm
Minimum recommended clearance from mast to allow for leg room	1000mm	1000mm	

WEIGHTS

Bath Hoist	28.2kgs	33.0kgs
Transporter	39.9kgs	44.0kgs
Battery Pack	—	4.0kgs

TRANSPORTER ONLY

Max width	610mm
Max depth	560mm
Max height	610mm
Seat height	510mm
Seat to footrest (adjustable)	430-480mm

ELECTRICAL SPECIFICATION

Batteries 2 x 12 VDC Rechargeable, sealed, lead acid gel
 Capacity 3.2 Ampere/hours
 Charger rated input 230 Vac50/60 Hz
 Charger rated output 27.4/29.0 VDC@0.8A
 Fuse – Hoist 25A Fast Blow " x 1.1/4"

Electric Shock Protection

Charger – Class II Double Insulated Hoist – Internal Power Source

Degree of Shock Protection

Charger – Type B

Hoist – Type B

Mode of operation – 15% Intermittent Duty.

Unihoist Ltd. has an established network of reputable distributors and dealers who will be pleased to handle all your purchasing, warranty, repair and maintenance enquiries.

Included with each lift is a prepaid Customer Satisfaction Card. Please take the time to fill it in and return it to Unihoist Ltd. Our products are guaranteed for a period of twelve months from the date of manufacture or twelve months from the date of purchase if commissioned by an authorised dealer. We recommend that all of our products are commissioned by your dealer and are supported by them for future servicing.

The dealer or distributor operates the warranty programme, so it is important to keep a record of their name address and telephone number so they can be contacted should any problem arise.

If you are in any doubt where your lift was purchased, Unihoist Ltd. can trace the supplier if you quote the serial number of the hoist.

REMEMBER: Contact your distributor for purchases, warranty, repairs, servicing and certified maintenance.

Manual Hoists		
Symptom	Possible Cause	Remedy
Winding handle will not turn	Safety nut engaged	Call service engineer
Seat will not rotate	Locking latch engaged	1. Release latch 2. If this does not work – call service engineer
Seat will not lock	Latch damaged	Call service engineer
Seat rotates when latch engaged	Column hub rotating	Call service engineer
Seat hits side of bath	Seat collar out of adjustment	Adjust collar (see setting up instructions)
Seat hits bottom of bath	1. Seat collar out of adjustment. 2. Bottom stop lost	1. Adjust collar (see setting up instructions). 2. Call service engineer
Base plate loose on fixings	1. Base plate fixing not fully tightened. 2. Base plate fixing damaged	1. Tighten down fixings (see Base plate fitting instructions) 2. Call service engineer
Grease leaking from column	End stop damaged	Call service engineer

Additional for Electric Hoists

Symptom	Possible Cause	Remedy
Hand control will not raise/lower seat	1. Damaged hand control 2. Hand control not plugged in fully 3. Control board failure. 4. Motor failed 5. Battery dead 6. Emergency stop button activated	1. Replace hand control 2. Fully plug in. 3. Call service engineer 4. Call service engineer 5. Charge or replace battery 6. Reset stop button



UNIHOIST LTD.

Unit B, Anvil Court,
Stanton Harcourt Road,
Eynsham, Oxon.
OX29 4UD

Tel: 01865 881881 Fax: 01865 883434

Email: unihoist@btconnect.com