EVOKO MINTO CONFERENCE PHONE

USER MANUAL

Version 1.2

EVOKO

TABLE OF CONTENTS

Initial configuration.....	03
Wall Mount instructions	04
Using the Evoko Minto.....	05
Halo light statuses.....	07
Cable storage.....	07
Charging & battery status	07
Auto power off.....	08
More about connections	08
Configuration from the Evoko Control Panel.....	09

1. Initial configuration

1. Remove plastic cover
2. Turn on by pressing the power button
3. Language selection
 - a. Available languages are: English, German, French, Swedish, Spanish, Italian, Russian, and Chinese (Mandarin).
 - b. To change the language for Voice Feedback: simultaneously hold down the + and - buttons for 2 seconds and you will hear a beeping sound. You will then hear instructions in the first available language.
 - c. Scroll between languages that are being vocally presented by pressing either + or -.
 - d. To select your desired language simply wait 4 seconds after hearing the language of your choice and it will be activated. You will hear the beeping sound again.

NOTE: The language setting will be saved for the next time the unit is restarted. Language settings can only be made when no active audio session is ongoing. No audio session can be started until the language setting is completed.

4. Set Voice Feedback mode
 - a. Activate or deactivate voice feedback using the voice feedback switch at the bottom of the unit.
 - b. Voice mode
 - i. The feedback switch is moved to "NORMAL" position.
 - c. Sound mode
 - i. The feedback switch is moved to "LIMITED" position.

NOTE: Certain system-critical voice feedback tags will also be played in limited mode.

5. Set backlight mode
 - a. To activate a backlight while charging in the Minto Wall Mount, simultaneously hold down the Bluetooth button and power button on the Evoko Minto. Do the same to deactivate.

NOTE: The default backlight mode is off.

NOTE: The unit can be rebooted by carefully inserting a paper clip in the hole marked with "Reset" on the bottom of the unit.

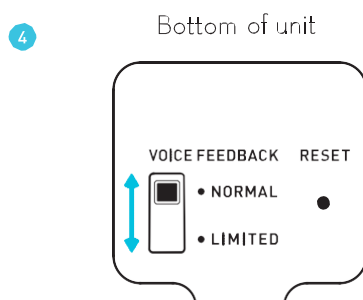
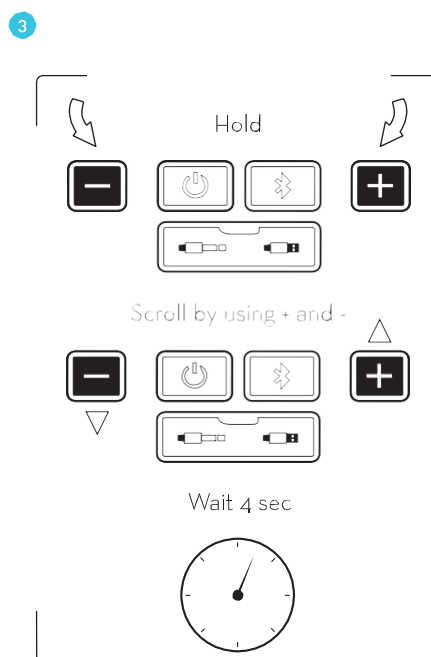
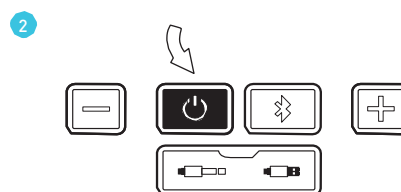
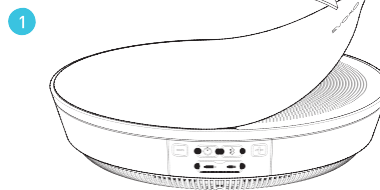

2. Wall Mount instructions

1. Start by unscrewing the two lower screws holding the Wall Mount and wall bracket together.
2. Fasten the Wall Mount bracket on to wall using suitable wall plugs and fastening screws. The cord is pre-assembled vertically, but it is possible to mount it in any direction.
3. Place Wall Mount on top of bracket and fasten from underneath with the screws which come with the package
4. Plug in the power adapter to a proper wall outlet.
5. Slide Minto into place by guiding it onto the back slot on the Wall Mount's protruding top edge.
6. When the Evoko Minto is placed on the wall mount it will automatically charge. When removed from the Wall Mount, voice feedback is provided on the battery status.

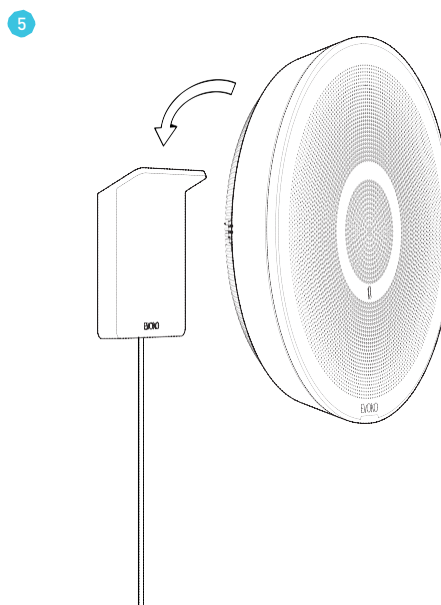
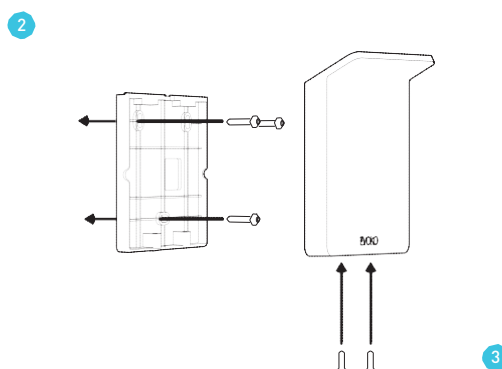
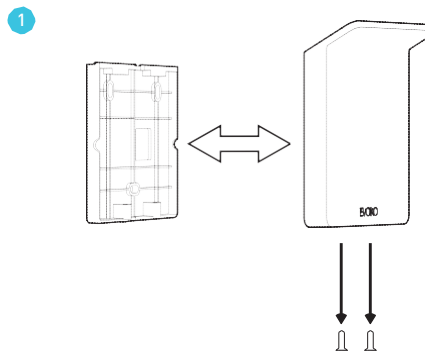

3. Using the Evoko Minto

1. Turn on by pressing the power button
2. Connect the Evoko Minto to the device you would like to use for your call, e.g. mobile phone, tablet or laptop. Evoko Minto can be connected using either Bluetooth, USB cable or audio cable and it can also be used with normal phone calls or VoIP services such as Skype or Micro soft Lync.

a. Bluetooth

- i. Press the Bluetooth button to initiate pairing mode.
- ii. The device ID is now visible and ready for connection.
- iii. Make sure that Bluetooth is activated on the device you would like to connect to the Evoko Minto and choose the Evoko Minto from the list of available Bluetooth devices.
- iv. When pairing is completed this is confirmed by sound and light feedback.
- v. To remove the Bluetooth connection, press and hold the Bluetooth button.

NOTE: The default device ID is "Evoko Minto" followed by the last four digits of the serial number of the unit (which can be found on the bottom of the unit).

NOTE: To change device the Bluetooth connection needs to be removed.

b. USB cable

- i. Open the cover on the front of the Evoko Minto.
- ii. Plug in the micro USB connector to the Evoko Minto and the standard USB connector to the device you would like to connect.

c. Audio cable

- i. Open the cover on the front of the Evoko Minto.
- ii. Plug in one end of the audio cable to the Evoko Minto and the other end to the device you would like to connect.

NOTE: When using the audio cable, the halo light turns green immediately once the cable is plugged in.

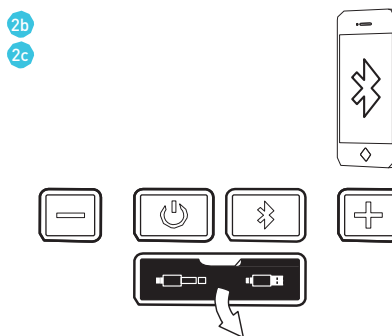
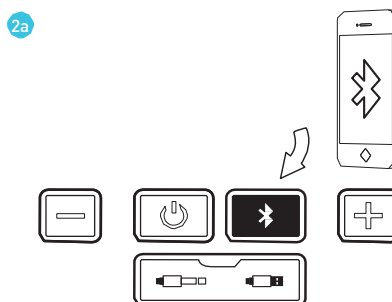
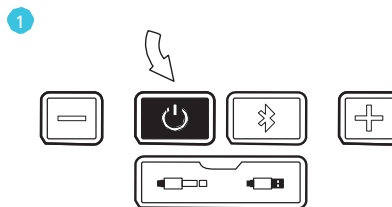

3. Use the connected device to make a call.

4. Air Swipe to mute.

a. Move your hand over the unit's "mute icon" at the center of the device at a distance of approximately 5 cm (2 in) to activate the mute function. The halo light turns red to clearly show to everyone that the microphones are turned off.

b. To unmute, just do another Air Swipe.

NOTE: The Mute function can only be activated in case a voice connection is valid.

5. Change the volume on the Evoko Minto or on the connected device. On the Evoko Minto,

a. Press + to increase, - to decrease volume. Each button press increases or decreases the volume by one step.

b. Hold down on button to increase or decrease volume continuously until maximum or minimum volume level is reached.

NOTE: The volume is a combination between the volume set on Evoko Minto and the volume set on the device connected to it. On the minimum volume level on Evoko Minto, the speaker sound is completely muted. When a connection is broken or changed, and when the Evoko Minto is powered off, the volume level is reset to its default value.

6. Press the power button once to receive voice feedback on battery status.

NOTE: This voice feedback will not be heard at the other end even if there is an ongoing call. For info about the different battery levels, please see the charging and battery section below.

7. Press and hold the power button to power off.

3



4

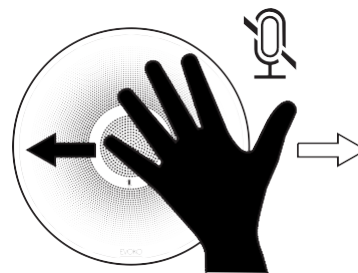

4. Halo light statuses

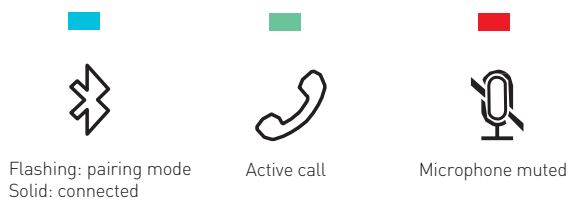

5. Cable storage

At the bottom of the Evoko Minto, there are two cable storage slots; one for the USB cable and one for the Audio cable. To use the cable, simply pull the cable tag and unwind the cable. To put the cable back in the cable storage slot, start by putting the connector without the cable tag in its slot and wind the cable in the direction shown by the symbols at the bottom of the Evoko Minto and finish by inserting the connector with the cable tag into its slot.

NOTE: Only one cable can be kept in the slot at one time. The Evoko Minto comes with the USB cable in the cable storage slot. The Audio cable can be found in the gift box.

6. Charging & battery status

Evoko Minto is stored and charged on its Wall Mount when not in use. When it is placed on the Wall Mount, it will automatically charge and when removed from the Wall Mount voice feedback will be given on the battery status.

Fully charging a completely empty battery takes 6 hours. You will then have a talk time of up to 8 hours.

If connected with a USB cable that is attached to a power source, e.g. the USB port of a laptop, this also provides power to the Evoko Minto and charges the battery.

NOTE: It is possible to buy Portable Chargers as accessories.

Battery level/ voice feedback	POWER BUTTON LIGHT	
	Charging	Running on battery
Full	Fixed white	Fixed white
High	Breathing white	Fixed white
Medium	Breathing white	Fixed white
Low	Breathing red	Flashing red
Critical	Breathing red	Flashing red

7. Auto power off

After 10 minutes of inactivity you will hear the voice feedback "Auto power off in 10 seconds". You will then hear: "Press any button to abort". Press any button on the Evoko Minto to abort the automatic power off. If no button is pressed within the 10 seconds, the unit will power off to save battery power.

NOTE: When an audio cable is connected, the auto power off function is disabled. If there is an active Bluetooth connection, the unit will stay on for 30 minutes before going into Automatic disconnect (see more in the Bluetooth section below) before the Auto power off timer starts.

8. More about connections

1. Audio cable
 - a. The audio cable connection has the highest priority.
 - b. Pressing the Bluetooth button will activate voice feedback: "Please remove audio cable before Bluetooth pairing" and maintain existing audio cable connection.
 - c. Inserting a micro USB cable will initiate charging, if the cable is connected to the device that will supply power, and keep existing 3.5mm cable connection.

NOTE: The audio cable used is an analog audio cable with a 4-pole 3.5 mm connector that works with most mobile phones. Some phone models however use the 3-pole connector.
2. USB cable
 - a. If an audio cable is connected, it has a higher priority and makes the USB connection MUTE.
 - b. If the Bluetooth button is pressed, it has higher priority and the device will switch to Bluetooth and initiate Bluetooth pairing.
 - c. The USB cable also provides power for the Evoko Minto. Charging with USB can also be done if the audio cable is connected or a Bluetooth connection is active.
3. Bluetooth connection
 - a. If the USB cable is connected, it will initiate and maintain the existing Bluetooth connection
 - b. If the audio cable is connected, it has higher priority and makes the Bluetooth connection mute. However if the audio cable is removed and the Bluetooth call is still active the call will be resumed.
 - c. **Cancel ongoing pairing or remove active connection:** Hold down the Bluetooth button to cancel Bluetooth pairing.
 - d. **Failed pairing:** Device will attempt pairing for 40 sec. If the pairing fails, please check the following and try again:
 - i. Make sure the device you are trying to connect has Bluetooth activated, is in visible mode, and is within 10m from the Evoko Minto.
 - ii. That the correct Evoko Minto unit is selected from the list of Bluetooth devices.
 - e. **Automatic disconnect:** After 30 minutes of inactivity, the voice feedback "Bluetooth will disconnect in 10 seconds. Press any button to abort." will be played. Press any button on the Evoko Minto to abort the automatic disconnection. If no button is pressed within the 10 seconds, the Bluetooth connection will be removed to save battery power.
 - f. **Bluetooth during Wall Mount (loudspeaker mode):** The device can be used as a wireless audio speaker when in the Wall Mount. Pairing is initiated by pressing the Bluetooth button, but works in the same way as regular pairing described above.

9. Configuration from the Evoko Control Panel

The settings in the Evoko Minto can also be changed in the Evoko Control Panel software. This is also where you do firmware upgrades.

Please visit www.evoko.se/support to download the Evoko Control Panel.

Please visit

www.evoko.se/support

if you have any questions
or need any help.

FCC Compliance

This device complies with Part 15 of the FCC Rules. Operation is subject to the following two conditions: (1) this device may not cause harmful interference, and (2) this device must accept any interference received, including interference that may cause undesired operation.

Warning: Changes or modifications to this unit not expressly approved by the party responsible for compliance could void the user's authority to operate the equipment.

NOTE: This equipment has been tested and found to comply with the limits for a Class B digital device, pursuant to Part 15 of the FCC Rules. These limits are designed to provide reasonable protection against harmful interference in a residential installation. This equipment generates, uses and can radiate radio frequency energy and, if not installed and used in accordance with the instructions, may cause harmful interference to radio communications.

However, there is no guarantee that interference will not occur in a particular installation. If this equipment does cause harmful interference to radio or television reception, which can be determined by turning the equipment off and on, the user is encouraged to try to correct the interference by one or more of the following measures:

- Reorient or relocate the receiving antenna.
- Increase the separation between the equipment and receiver.
- Connect the equipment into an outlet on a circuit different from that to which the receiver is needed.
- Consult the dealer or an experienced radio/TV technician for help.

Responsible party:

Evoko Unlimited AB, c/o DMJ Technologies, Northeast Territory 2, NJ, NY Metro, 140 Henley Avenue, New Milford, NJ07646, USA. Tel.+1 201 261-5560.

Evoko Minto - Model number EM1001.

Warnings:

- "3.5 mm audio cables must be shorter than 3 meters."
- "The socket-outlet shall be installed near the equipment and easily be accessible."
- "Excessive sound pressure from earphones and headphones can cause hearing loss."

CAUTION:

Danger of explosion if battery is incorrectly replaced. Replace only with the same or equivalent type.



Hereby, Evoko Unlimited AB declares that this conference phone is in compliance with the essential requirements and other relevant provisions of directive 1999/5/EC. The declaration of conformity may be consulted at: www.evoko.se/downloads

