



**Get
2 MORE YEARS
with ProtectionPlus™**

Available in 40 and 60 Gallon Electric Models

- ▶ Upgradeable 6 Year Limited Tank Warranty to 8 Years*
- ▶ 2 Year Limited Parts Warranty*

- Unique professional design
- EverKleen™ self cleaning dip tube
- Oversized magnesium anode rod
- R-Foam insulation (up to R-20)
- Temperature and pressure relief valve included
- Factory installed plumbing nipples
- Professional installation
- Certified to the CAN/CSA C191.1-M90 efficiency standard

* See Residential Warranty Information Brochure for complete warranty information.



DESCRIPTION				FEATURES					ROUGHING IN DIMENSIONS							
MODEL NUMBER	STORAGE CAPACITY			ELEMENTS QTY.	STANDARD ELEMENTS				OVERALL HEIGHT A		DIAMETER B		HEIGHT TO DRAIN VALVE C		ESTIMATED SHIPPING WEIGHT	
	U.S. GALS.	IMP. GALS.	LITERS		208 VOLT		240 VOLT		IN.	MM	IN.	MM	IN.	MM	LBS.	KG
					WATT.	AMP.	WATT.	AMP.								
PRO415TM	45	37.5	170	2	2250	10.8	3000	12.5	46	1168	21-3/4	552	3-1/2	89	117	53
PRO425TM	45	37.5	170	2	2250	10.8	3000	12.5	46	1168	24-1/4	616	3-1/2	89	134	61
PRO615TM	72	60	270	2	3380	16.3	4500	18.8	59	1499	23	584	3-1/2	89	177	80
PRO620TM	72	60	270	2	3380	16.3	4500	18.8	59	1499	24-1/2	622	3-1/2	89	188	85

Notes: 3/4" N.P.T. Outlet, Inlet, Anode Rod, T&P Valve Connections. • 140°F Thermostat Setting. • Not available in 3 phase wiring.

The Exclusive Professional Installation Warranty

When this Rheem PROFESSIONAL water heater is installed by a licensed contractor, the consumer can upgrade the limited tank warranty from 6 to 8 years and the limited parts warranty from 1 to 2 years by returning to Rheem the warranty registration card and a copy of the contractor's invoice.

This Rheem exclusive warranty upgrade feature enhances your value as a plumbing professional. A professional installation is a better installation!

Refer to the warranty certificate enclosed with each heater for specific details.

PROTECTIONPLUS™

8

YEAR LIMITED TANK WARRANTY

10

BECOMES

Before purchasing this appliance, read important energy cost and efficiency information available from your supplier.

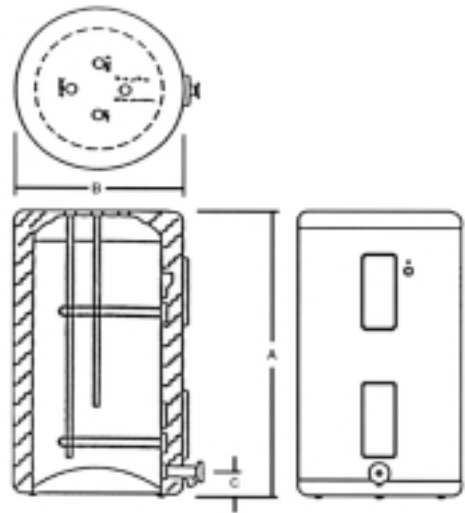

In keeping with its policy of continuous progress and product improvement, Rheem reserves the right to make changes without notice.

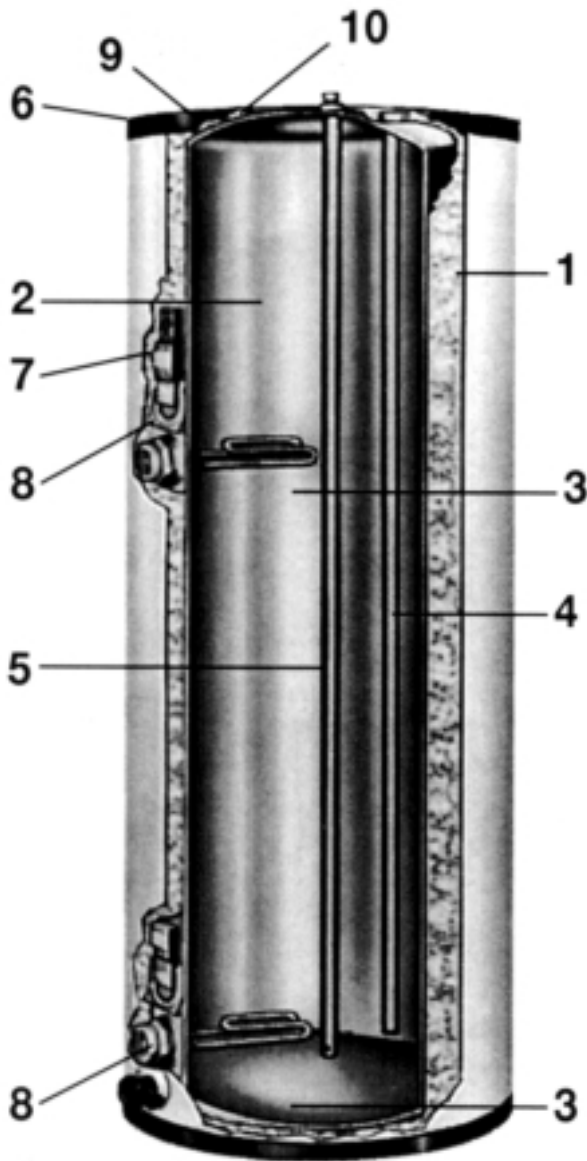

CONSTRUCTION FEATURES

1. **R-Foam Insulation** – Rigid polyurethane foam for improved economy and fuel savings. The use of our patented insulator foam stops allows R-Foam to be injected directly between the tank and outer jacket. This uniform R-Foam application minimizes the possibility of costly heat loss caused by uninsulated areas (voids) common to some other foam processes.
2. **Rheemglas Tank** – Rheem water heater tanks are made of special materials with exacting care. The tank surface is coated with an exclusive porcelain formula called Rheemglas and fused to the solid steel at 1600°F. The result is a smooth, tough, glass-like lining that effectively resists the corrosive attacks of hot water chemicals, thereby assuring long water heater life. Tank is designed and tested to withstand 300 PSI hydrostatic test pressure, for working pressure of 150 PSI.
3. **Elements** – High quality copper.
4. **Dip Tube** – EverKleen™ self-cleaning dip tube reduces sediment buildup by channeling water through a specially developed inlet tube.
5. **Anode Rod** – Premium grade, heavy duty anode provides increased cathodic protection for longer tank life. Effective in varying water conditions.
6. **Electrical Junction Connection** – (For 1/2" and 3/4" conduit) Front location for easy installation.
7. **Over Temperature Protector** – Automatically cuts off power in excess temperature situations.
8. **Automatic Temperature Control** – Thermostat keeps water at desired temperature.
9. **Hot Water Outlet** – Draws water from top of storage tank where temperature is highest.
10. **3/4" Relief Valve Coupling.**