



ASSEMBLY, INSTALLATION, AND REMOVAL OF CONTACTS AND MODULES

FOR 75 OHM AND 75 OHM HD COAXIAL CONTACTS AND MODULES

Table of Contents

SECTION 1 RECEIVER CONTACT ASSEMBLY INSTRUCTIONS

SECTION 2 ITA CONTACT ASSEMBLY INSTRUCTIONS

SECTION 3 CONTACT INSTALLATION AND REMOVAL INSTRUCTIONS

SECTION 4 MODULE INSTALLATION AND REMOVAL INSTRUCTIONS

SECTION 5 CROSS REFERENCE TABLES

SECTION 6 PRODUCT PERFORMANCE SPECIFICATIONS

75 OHM COAXIAL RECEIVER CONTACT ASSEMBLY

PART # 610 104 157 FOR RG179

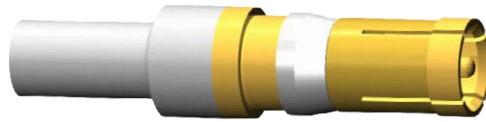

TOOLS REQUIRED

Coaxial 75 Ohm Receiver Crimp Tool Kit, Part # 910 102 106

- Contains- Crimp Tool and Locator Die Assembly, Part # 910 104 137
- .128 Hex Crimp Tool, Part # 910 104 139

ASSEMBLY INSTRUCTIONS

1. Strip wire (**Figure A**).
2. Tin center conductor (only for wires that are soldered).
3. Slide $\frac{3}{16}$ shrink tubing ($\frac{1}{2}$ " long [12.7 mm]) and crimp ring onto wire (**Figure B**).
4. Place contact onto center conductor of wire (**Figure B**) and crimp into position using VPC crimp tool, Part # 910 104 137, at setting #1 (or solder). Measure crimp at 0.028/0.032 [0.71/0.81 mm] opening.
5. Rotate dielectric to flair shield over the contact body (**Figure C**).
6. Insert connector barrel between wire shield and dielectric until dielectric bottoms inside (**Figure C**).
7. Slide crimp ring against shoulder of body (**Figure D**) and use .128 Hex Crimp Tool, Part # 910 104 139 (**Figure E**), to crimp.
8. Slide tubing into position and shrink (**Figure F**).

Dimensions shown: [millimeters]
inches



Figure A. Strip lengths.

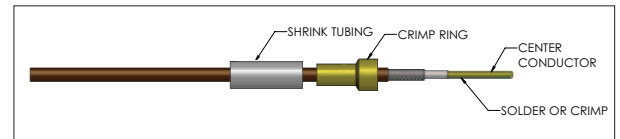

Figure B. Slide shrink tubing and crimp ring onto wire.

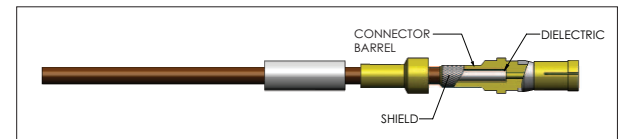

Figure C. Ensure dielectric bottoms inside wire.

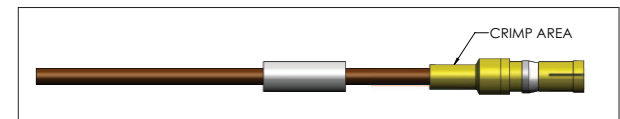

Figure D. Apply crimp ring.



Figure E. Crimp Tool, Part # 910 104 139.



Figure F. Apply shrink tubing.

75 OHM HD COAXIAL RECEIVER CONTACT ASSEMBLY

PART # 610 102 133 FOR SUB-MINIATURE 59/U



Dimensions shown: [millimeters]
inches

TOOLS REQUIRED

Hex Crimp Tool for Outer Shield, Part # 910 104 139

ASSEMBLY INSTRUCTIONS

- Strip wire (**Figure A**).
- Slide shrink tubing and crimp ring onto wire (**Figure B**).
- Remove 0.05" [1.27 mm] of foil (**Figure B**). Leave remaining foil flat against the dielectric.
- Fold shield back without disturbing the foil and tin the center conductor (**Figure C**).
- Slide the wire into the contact inserting the center conductor into the solder cup of the contact center conductor. Rotate the contact in the direction the foil is wrapped to facilitate the installation.
- Check the following:
 - No foil in the window.
 - No braid in the window.
 - The center conductor of the wire is inserted into the solder cup of the contact (**Figure D**).
- Solder the center conductor of the wire to the center conductor of the contact. Clean the solder joint and contact.
- Push the shield over the knurled portion of the contact (**Figure E**).
- Trim any braid exceeding past the knurled area of the contact (**Figure E**).
- Slide the crimp ring over the contact (**Figure F**).
- If the crimp ring does not slide over the shield:
 - Pull the crimp ring back.
 - Comb out the braid.
 - Repeat steps 8 – 11.
- Crimp the contact using the .178 Hex Crimp Tool, Part # 910 104 139 (**Figure G**), in the location shown in **Figure F**.
- Slide tubing into position and shrink (**Figure H**).

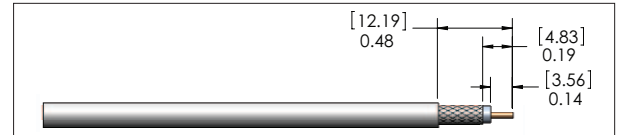

Figure A. Strip lengths.

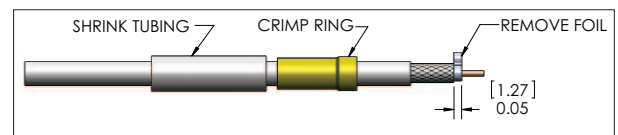

Figure B. Slide shrink tubing and crimp ring onto wire.

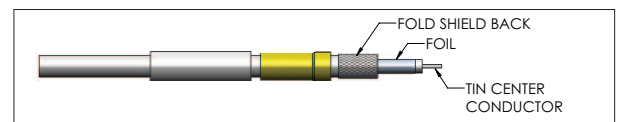

Figure C. Fold shield back.

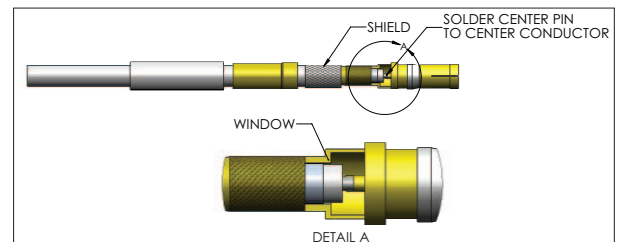

Figure D. Center pin and center conductor.

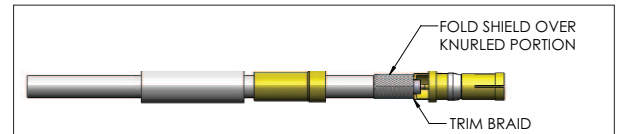

Figure E. Trim braid.

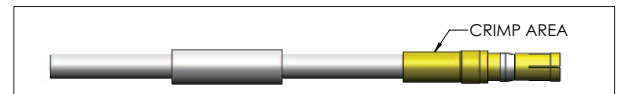

Figure F. Apply crimp ring.



Figure G. Crimp tool, Part # 910 104 139.

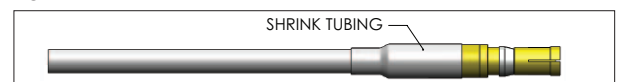

Figure H. Shrink tubing.

75 OHM COAXIAL ITA CONTACT ASSEMBLY

PART # 610 103 169 FOR RG179



TOOLS REQUIRED

Coaxial 75 Ohm ITA Crimp Tool Kit, Part # 910 102 107

Contains- Crimp Tool and Locator Assembly, Part # 910 104 138
Hex Crimp Tool, Part # 910 104 139

Dimensions shown: [millimeters]
inches

ASSEMBLY INSTRUCTIONS

1. Strip wire (**Figure A**).
2. Tin center conductor (only for wires that are soldered).
3. Slide $\frac{3}{16}$ " shrink tubing ($\frac{1}{2}$ " long [12.7 mm]) and crimp ring onto wire (**Figure B**).
4. Place contact onto center conductor of wire (**Figure B**) and crimp into position using VPC crimp tool, Part # 910 104 138 at setting #1 (or solder). Measure crimp at 0.028/0.032 [0.71/0.81 mm] opening.
5. Rotate dielectric to flair shield over the contact body (**Figure C**).
6. Snap center conductor into body and pull back to make sure it is locked in place. Slide crimp ring against shoulder of body and use .128 Hex die to crimp (**Figure E**).
7. Using .128 Hex Crimp Tool, Part # 910 104 139 (**Figure D**).
8. Slide tubing into position and shrink (**Figure F**).

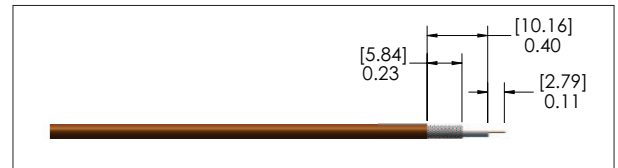

Figure A. Strip lengths.

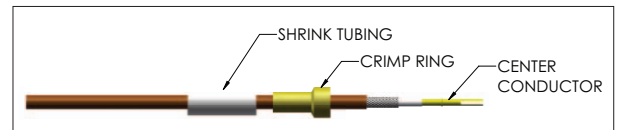

Figure B. Slide shrink tubing and crimp ring onto wire.

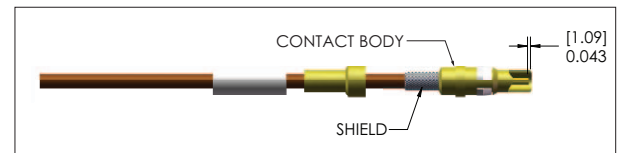

Figure C. Ensure center conductor is locked in place, then apply crimp ring.



Figure D. Hex Crimp Tool, Part # 910 104 139 .

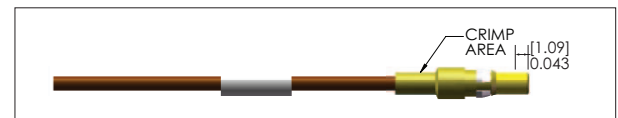

Figure E. Crimp contact.

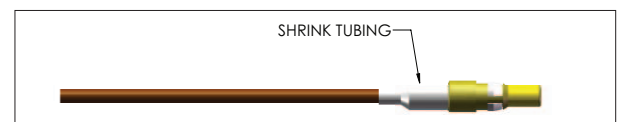

Figure F. Apply shrink tubing.

75 OHM HD COAXIAL ITA CONTACT ASSEMBLY

PART # 610 102 132 FOR SUB-MINIATURE 59/U



TOOLS REQUIRED

Tool, Hex Crimp for Outer Shield, Part # 910 104 139

Dimensions shown: [millimeters]
inches

ASSEMBLY INSTRUCTIONS

- Strip wire (**Figure A**).
- Slide shrink tubing and crimp ring onto wire (**Figure B**).
- Remove 0.05" [1.27 mm] of foil (**Figure B**). Leave remaining foil flat against the dielectric.
- Fold shield back without disturbing the foil and tin the center conductor (**Figure C**).
- Slide the wire into the contact inserting the center conductor into the solder cup of the contact center conductor. Rotate the contact in the direction the foil is wrapped to facilitate the installation.
- Check the following:
 - No foil in the window.
 - No braid in the window.
 - The center conductor of the wire is inserted into the solder cup of the contact (**Figure D**).
- Solder the center conductor of the wire to the center conductor of the contact. Clean the solder joint and contact.
- Push the shield over the knurled portion of the contact (**Figure E**).
- Trim any braid exceeding past the knurled area of the contact (**Figure E**).
- Slide the crimp ring over the contact (**Figure F**).
- If the crimp ring does not slide over the shield:
 - Pull the crimp ring back.
 - Comb out the braid.
 - Repeat steps 8 – 11.
- Crimp the contact using the .178 Hex Crimp Tool, Part # 910 104 139 (**Figure G**), in the location shown in **Figure F**.
- Slide tubing into position and shrink (**Figure H**).

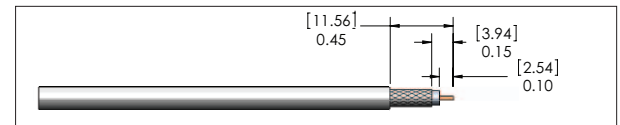

Figure A. Strip lengths.

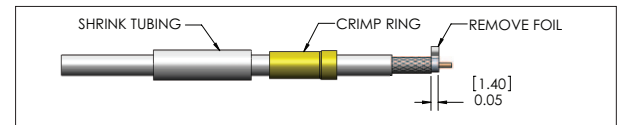

Figure B. Remove foil.

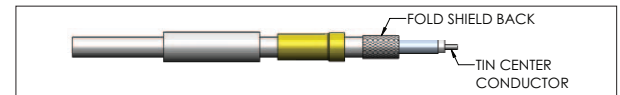

Figure C. Fold shield braid back and tin center conductor.

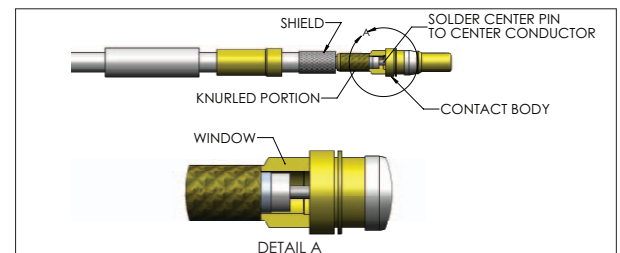

Figure D. Use the window to check the center conductor is inserted properly.

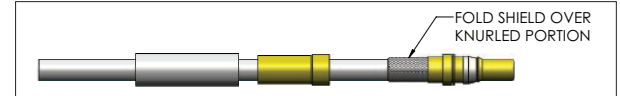

Figure E. Fold shield over knurled portion.

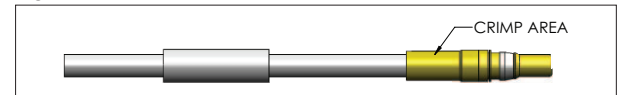

Figure F. Crimp contact.



Figure G. Hex Crimp Tool, Part # 910 104 139.

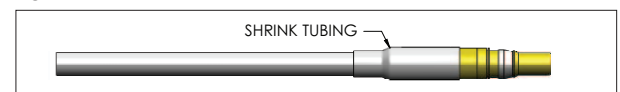

Figure H. Apply shrink tubing.

75 OHM COAXIAL RECEIVER CONTACT INSTALLATION AND REMOVAL

PART # 610 104 157 / 610 102 133

TOOLS REQUIRED

Phillips Screwdriver
0.05" Allen Wrench (75 Ohm HD only)
75 Ohm Coaxial Receiver/ITA Extraction Tool, Part # 910 112 117

CONTACT INSTALLATION INSTRUCTIONS

- Assemble the contact to the respective wire.
NOTE: For more information concerning the process of crimping the contact please see contact assembly instructions in Section 1 of this User's Manual.
- Insert the terminated contact into the back of the assembled module. The contact can only go into one side. Once in place, pull the wire slightly to ensure that the contact is seated.

CONTACT REMOVAL INSTRUCTIONS

- Remove the module from the receiver frame.
NOTE: For more information concerning the process of removing the module from the receiver frame, see module installation and removal instructions in Section 4 of this User's Manual.
- Use a Phillips screwdriver (0.05" Allen Wrench for 75 Ohm HD) to remove the 2-56 screws located at the top and bottom of the module (**Figure A**).
- Grasp the module halves and apply force in opposite directions, rocking the ends of the module while slightly pulling the top of the module away from the mating bottom section. Be sure to open both sides of the module simultaneously or contacts could be damaged.
- Place the 75 Ohm Receiver/ITA Extraction Tool, Part # 910 110 117 (**Figure B**), over the contact to be removed/replaced. Use care to keep the tool perpendicular to the surface of the module, otherwise the tool or the contact could be bent.
- Once the extraction tool is seated and the retaining ring tabs on the contact are compressed, depress the plunger. The contact will be pushed out of the rear of the module.

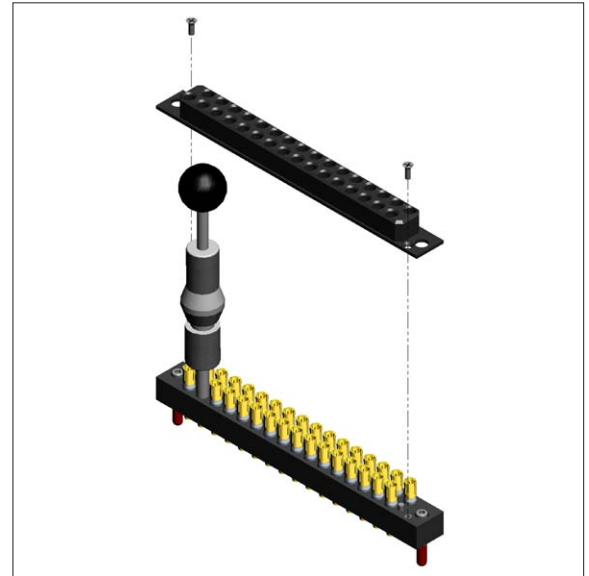

Figure A. There are two screws holding the module halves together.

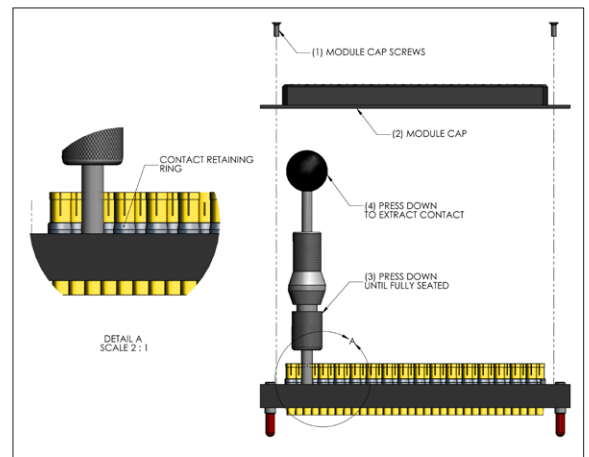

Figure B. Extraction Tool, Part # 910 112 117.



DO NOT DEPRESS THE PLUNGER UNTIL THE TIP OF THE EXTRACTION TOOL HAS BEEN FULLY SEATED INTO THE MODULE AND COMPRESSED THE RETAINING RING TABS ON THE CONTACT.

- Replace the module cap using both hands to push the separated halves together. Replace and tighten the module retaining screws to a maximum torque of 2 in-lbs [0.23 Nm].

NOTE: The process shown here uses standard/90 series modules. The same process is used for modules from other series.

NOTE: If you are using a hybrid module, you may need to reference the User's Manual for the other contact type for extraction instructions.

75 OHM COAXIAL ITA CONTACT INSTALLATION AND REMOVAL

PART # 610 103 169 / 610 102 132

TOOLS REQUIRED

75 Ohm Coaxial Receiver/ITA Extraction Tool, Part # 910 112 117

CONTACT INSTALLATION INSTRUCTIONS

1. Assemble the contact to the respective wire.
NOTE: For more information concerning the process of crimping the contact please see contact assembly instructions in Section 2 of this User's Manual.
2. Insert the terminated contact into the back of the module. Push the contact forward until the crimp is inside the module housing. Once in place, pull the wire slightly to ensure the contact is seated.

CONTACT REMOVAL INSTRUCTIONS

1. Remove the module from the ITA frame.
NOTE: For more information concerning the process of removing the module from the ITA frame, see module installation and removal instructions in Section 4 of this User's Manual.
2. Place the 75 Ohm Coaxial Receiver/ITA Extraction Tool, Part # 910 110 117 (**Figure A**), over the contact to be removed/replaced. Use care to keep the tool perpendicular to the surface of the module as not to bend the tool or the contact to be removed. Rotate the tool slightly while pushing it into the counter bore on the mating side of the module (**Figure B**).

3. Once the extraction tool is seated properly and the retaining ring tabs on the contact are compressed, push the plunger. The contact will be pushed out of the rear of the module.



DO NOT DEPRESS THE PLUNGER ON THE BACK OF THE EXTRACTION TOOL UNTIL THE TIP OF THE EXTRACTION TOOL HAS BEEN FULLY SEATED INTO THE MODULE AND COMPRESSED THE RETAINING RING TABS ON THE CONTACT.

NOTE: The process shown here uses standard/90 series modules. The same process is used for modules from other series.

NOTE: If you are using a hybrid module, you may need to reference the User's Manual for the other contact type for extraction instructions.

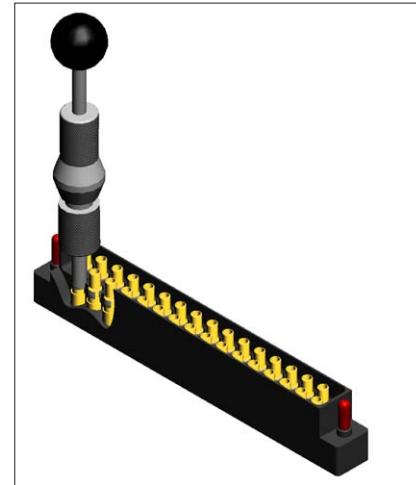

Figure A. Ensure the tool is kept perpendicular to prevent bent contacts.

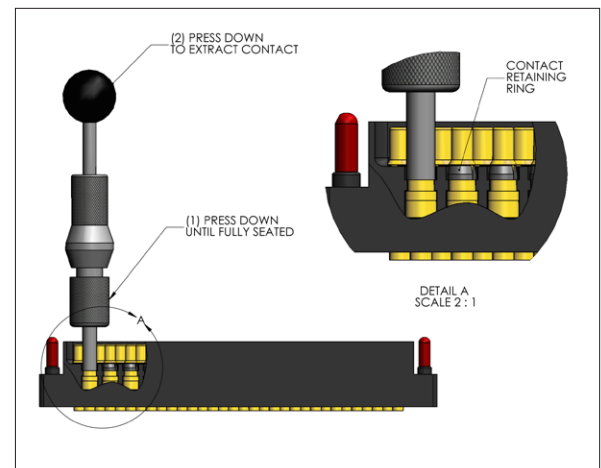

Figure B. Extraction Tool, Part # 910 112 117.

75 OHM COAXIAL STANDARD/90 SERIES MODULE INSTALLATION AND REMOVAL

TOOLS REQUIRED

$\frac{3}{32}$ Allen Wrench

INSTALLATION INSTRUCTIONS

1. Place the module in the receiver or ITA until the upper and lower module screws touch the mating holes in the inner frame. Ensure that Position 1 is located at the top for systems in which the modules are oriented vertically or to the left for systems in which the modules are oriented horizontally.
2. Using a $\frac{3}{32}$ Allen wrench, tighten the top screw 1 to 2 full revolutions, while pushing lightly against the face of the module.
3. Maintain this pressure while tightening the bottom screw 1 to 2 full revolutions.
4. Repeat this sequence until the module is seated. Torque the screw to 4 in-lbs [0.45 Nm].

REMOVAL INSTRUCTIONS

1. To remove, loosen the top screw 1 to 2 full revolutions. Loosen bottom screw 1 to 2 full revolutions.
2. Repeat this sequence until the module is separated from the receiver or ITA.

NOTE: Push or pull the module evenly from the top and bottom to prevent damage to the module.

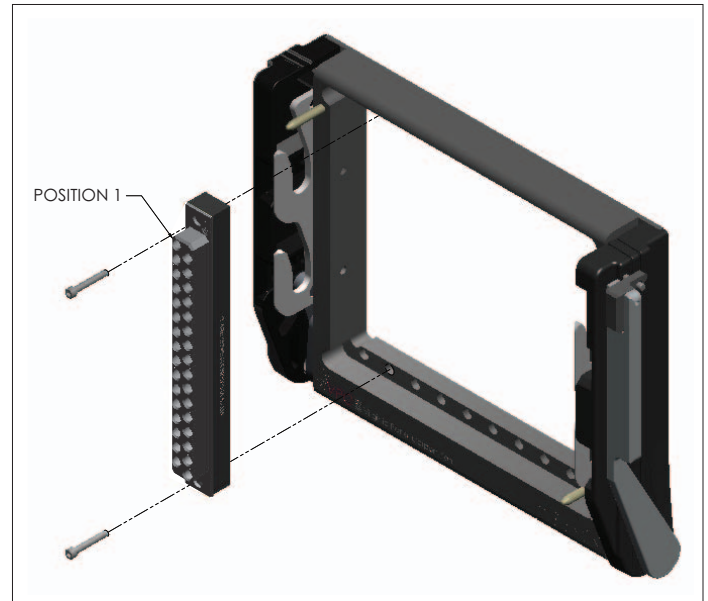

Figure A. Receiver Module.

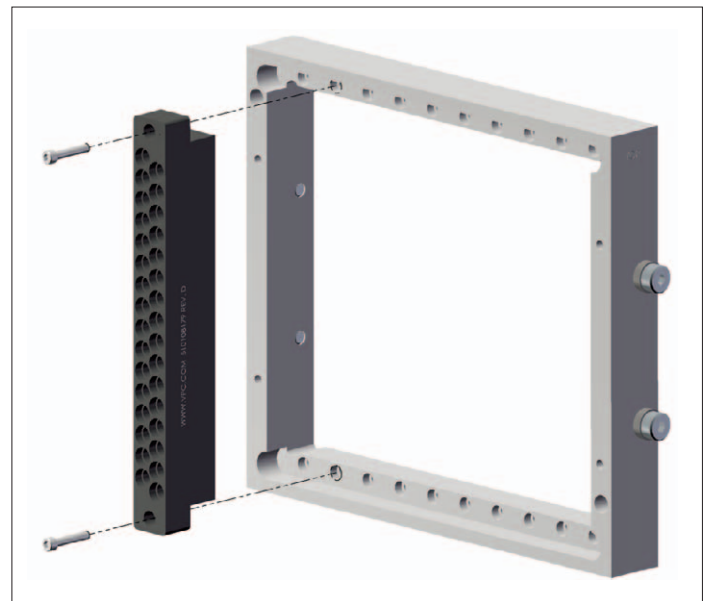

Figure B. ITA Module.

75 OHM HD COAXIAL ICON MODULE INSTALLATION AND REMOVAL

TOOLS REQUIRED

Phillips Head Screwdriver

INSTALLATION INSTRUCTIONS

NOTE: The receiver strain relief plate or the ITA cover may need to be removed prior to installing or removing an iCon module. Please refer to the appropriate User's Manual for instructions on how to perform these steps.

1. Place the module in the receiver or ITA until the upper and lower module screws touch the mating holes in the inner frame. Install modules such that Position 1 is located at the top of the ITA/ receiver frame.
2. Using a Phillips head screwdriver, tighten the top screw 1 to 2 full revolutions, while pushing lightly against the face of the module.
3. Maintain this pressure while tightening the bottom screw 1 to 2 full revolutions.
4. Repeat this sequence until the module is seated. Torque the screw to 1.5 in-lbs [0.16 Nm].

REMOVAL INSTRUCTIONS

1. To remove, loosen the top screw 1 to 2 full revolutions. Loosen bottom screw 1 to 2 full revolutions.
2. Repeat this sequence until the module is separated from the receiver or ITA.

NOTE: For optimum performance and system longevity, distribute the contact load evenly throughout the module.

NOTE: Push or pull the module evenly from the top and bottom to prevent damage to the module.

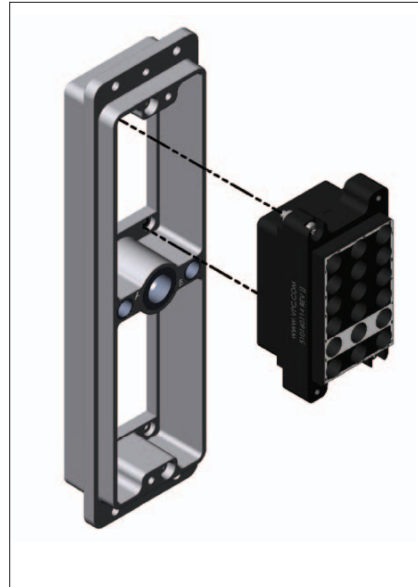

Figure A. Receiver Module.

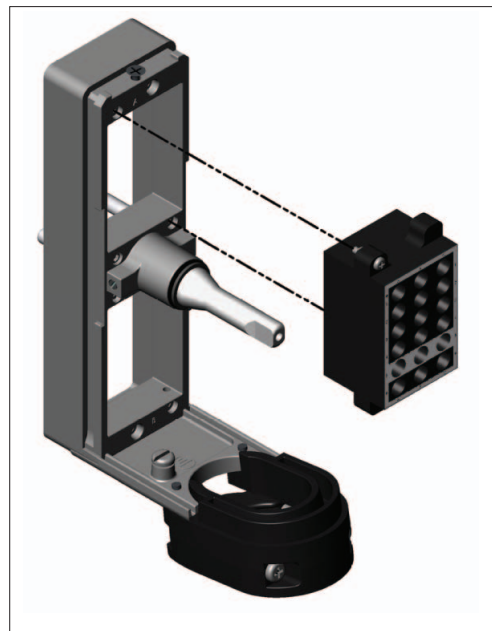

Figure B. ITA Module.

CROSS REFERENCE TABLES

RECEIVER CONTACTS	STANDARD/ 90 SERIES RECEIVER MODULES		ICON RECEIVER MODULES		CRIMP TOOLS		EXTRACTION	MISC.
	510 104 249	510 104 251	510 160 114	510 160 115	910 104 137	910 104 139	910 112 117	910 102 106
610 102 133		X	X	X		X	X	
610 104 157	X				X	X	X	X

ITA CONTACTS	STANDARD/ 90 SERIES ITA MODULES		ICON ITA MODULES		CRIMP TOOLS		EXTRACTION	MISC.
	510 108 179	510 161 114	510 161 115	910 104 138	910 104 139	910 112 117	910 102 107	
610 102 132	X	X	X		X	X		
610 103 169	X			X	X	X	X	

75 OHM COAXIAL CONTACT ELECTRICAL SPECIFICATIONS

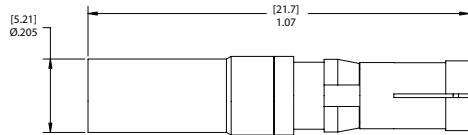

Receiver Contact
Part # 610 104 133

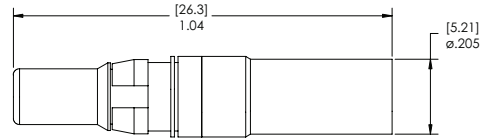

ITA Contact
Part # 610 102 132

Dimensions shown: [millimeters]
inches

Electrical Specifications

CHARACTERISTIC IMPEDANCE	75 Ohms
FREQUENCY RANGE	DC 2 GHz
CONTACT RESISTANCE	Center: 5 Milliohms Outer: 3 Milliohms
DIELECTRIC BREAKDOWN	800 V DC
VSWR	Less than or equal to 1.31 @ 2 GHz
INSERTION LOSS	0.5 db @ 500 MHz
RECOMMENDED CABLE	RG179 (75 Ohm) / SM59u (75 Ohm HD)

Mechanical Characteristics

CYCLE LIFE	20,000
MATING FORCE	2.0 lbs max. [0.9 kg]

Material

SHIELD (ITA)	360 Brass alloy per QQ-B-626 .000030 Au per MIL-G-45204, Type II, over .0001 Ni per QQ-N-290
SHIELD (RCVR)	360 Brass alloy per QQ-B-626 .000030 Au per MIL-G-45204, Type II, over .0001 Ni per QQ-N-290
CENTER CONDUCTOR (ITA)	360 Brass alloy per QQ-B-626 .000030 Au per MIL-G-45204, Type II, over .0001 Ni per QQ-N-290
CENTER CONDUCTOR (RCVR)	BeCu HDM25 .000030 Au per MIL-G-45204, Type II, over .0001 Ni per QQ-N-290
CRIMP RING	360 Brass alloy per QQ-B-626 .0001 Au per QQ-N-290
RETAINING RING	BeCu alloy M25 .0001 Ni per QQ-N-290
DIELECTRIC	Teflon (PTFE)