

FUEGO

TM



## Fuego 01

What you see—and what you don't—is an architectural reinvention of outdoor grilling. A fully retractable lid. Teak and slate countertops wide enough for food, glasses, and elbows. Ample storage areas tucked out of sight. Dual burners with patented Quick Change Drawer System for multiple fuel options. Smooth wheeling agility, and a modular accessory system pegged for optional trays and tools. Fuego 01 delivers it all. And then some.

# FG01AMG Specifications

## Burner Options

- 2 standard stainless burners 37,000 btu/hr.
- Optional Infrared Drawer 18,500 btu/hr.
- Optional Charcoal Drawer

## Colors

Stainless steel with natural teak and slate

## Features

- Patented Quick Change Drawer System
- Multiple fuel options
- Fully retractable cooking lid
- Slate countertops with hidden storage
- Modular Accessory System
- Two sliding drawers for propane tank and storage
- Built in Residue Trays
- Battery ignition
- Built in wheels for easy mobility

## Grilling Area

468 sq. in.

## SS Gas Burners

2 @ 18,500 BTU/hr. (included)

## Grill Grates

Cast iron, enamel coated

## Controls

Manual knobs

## Shipping Weight

395 lbs.

## Shipping Dimensions:

D42 W34 H44

## Gas Requirements

### Natural

- 1/2" NPT male with 3/8" flare adaptor
- Operational Pressure: 4.0" W.C.
- LP to NG conversion kit is available from your dealer

### Propane

- 1/2" NPT male with 3/8" flare adaptor
- LP hose is included (LP tank not included)
- Operational Pressure: 11" W.C.

## Accessories

- FA01ACD Charcoal Drawer Option
- FA01AID Infrared Drawer Option
- FA00AGC Gas Conversion Kit
- FA00AGP Griddle/ Flat Plate Option
- FA00ALL Large Cooking Lid
- FA00ATH Paper Towel Holder
- FA00ACT Ceramic Tray Set
- FA00ASP Spice/ Accessory Jars
- FA01AOC Outdoor Cover

**Warranty:** All grills are covered by a one (1) year comprehensive parts and labor warranty. In addition, a five (5) year limited parts warranty covers specific parts by model.

A lifetime warranty covers all stainless steel components against manufacture related defects. This excludes discoloration or surface corrosion resulting from improper use and care. Please refer to user manual for proper care and maintenance.

Specifications are subject to change without notice. Please call 888.88.FUEGO or check our website at [www.fuegoliving.com](http://www.fuegoliving.com) for potential specification updates.

Fuego North America Roundhouse One, 1500 Sansome Street, #100, San Francisco, CA 94111

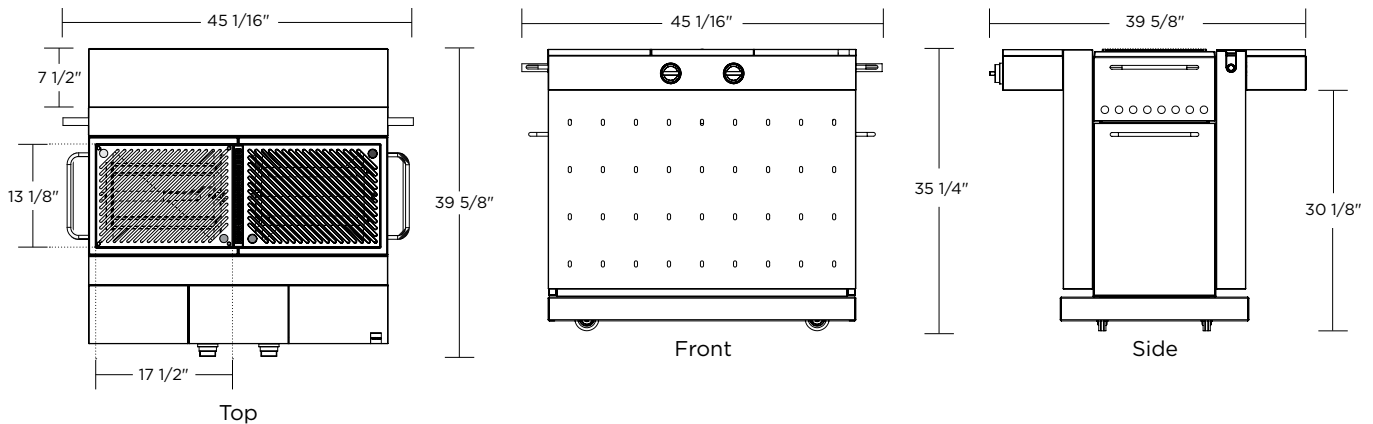

**FUEGO**

TM



## **Fuego 02**

Fuego 02 is a scaled-down interpretation of the Fuego 01. A simplified grill, it possesses the same signature features as its larger sibling. Wood and slate countertops for prepping food and stirring margaritas. Trays pegged on the side. A hidden storage area. Wheeled mobility. They're all here.

# FG02AMG/FG02AMI Specifications

## Burner Options

Gas, Infrared

## Colors

Stainless steel with natural teak and slate

## Features

- Multiple fuel options
- Fully retractable cooking lid
- Slate and Teak countertops with hidden storage
- Modular Accessory System
- Sliding drawer for propane tank
- Built in Residue Trays
- Battery ignition
- Built in wheels for easy mobility

## Grilling Area

252 sq. in.

## SS Gas Burner

1 @ 18,500 BTU/hr. (FG02AMG)

## Infrared Burner

1 @ 18,500 BTU/hr. (FG02AMI)

## Grill Grates

Cast iron, enamel coated

## Controls

Manual knobs

## Shipping Weight

215 lbs.

## Shipping Dimensions:

D31 W28 H45

## Gas Requirements

### Natural

1/2" NPT male with 3/8" flare adaptor  
Operational Pressure: 4.0" W.C.  
LP to NG conversion kit is available from your dealer

### Propane

1/2" NPT male with 3/8" flare adaptor  
LP hose is included (LP tank not included)  
Operational Pressure: 11" W.C.

## Accessories

- FA00AGC Gas Conversion Kit
- FA00AGP Griddle/ Flat Plate Option
- FA00ALL Large Cooking Lid
- FA00ATH Paper Towel Holder
- FA00ACT Ceramic Tray Set
- FA00ASP Spice/ Accessory Jars
- FA02AOC Outdoor Cover

**Warranty:** All grills are covered by a one (1) year comprehensive parts and labor warranty. In addition, a five (5) year limited parts warranty covers specific parts by model.

A lifetime warranty covers all stainless steel components against manufacture related defects. This excludes discoloration or surface corrosion resulting from improper use and care. Please refer to user manual for proper care and maintenance.

Specifications are subject to change without notice. Please call 888.88.FUEGO or check our website at [www.fuegoliving.com](http://www.fuegoliving.com) for potential specification updates.

Fuego North America Roundhouse One, 1500 Sansome Street, #100, San Francisco, CA 94111

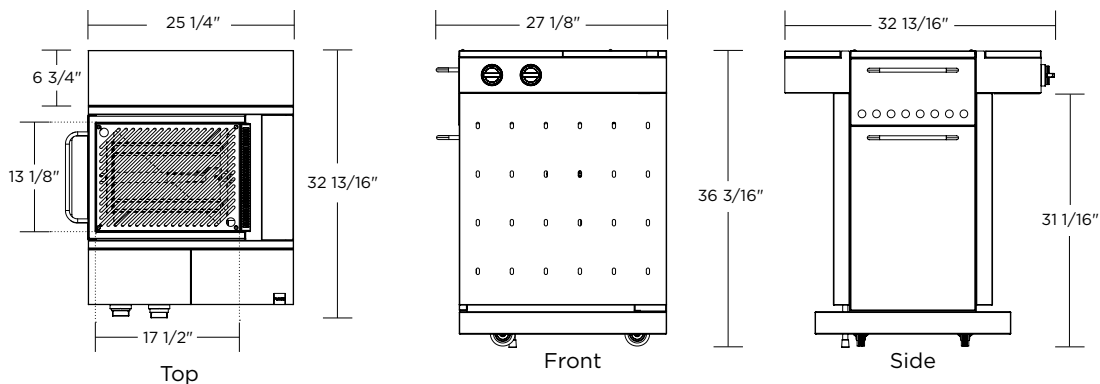

**FUEGO**

TM



## **Fuego 02 Electric**

Seasoned with enough bells and whistles to send conventional electric grills running for cover, Fuego 02 Electric takes modernism to the top. Teak and slate countertops with hidden storage areas. A removable cord for trip-free walking. A streamlined retractable lid. A convenient modular accessory system. They're all here and more.

# FG02AME Specifications

## Burner

Electric Element  
 Power Rated 1650W  
 Voltage Rated 120V, 60Hz  
 Amps, 13.75

## Colors

Stainless steel with natural teak and slate

## Features

Fully retractable weather lid  
 Slate and teak countertops with hidden storage  
 Modular Accessory System  
 Sliding storage drawer  
 Built in Residue Trays  
 Built in wheels for easy mobility  
 Wheel Brake  
 6' Removable Cord

## Temperature Range

Low/ High 150-700 degrees

## Grilling Area

252 sq. in.

## Grill Grates

Cast iron, enamel coated

## Controls

Manual knob

## Shipping Weight

251 lbs.

## Shipping Dimensions:

D31 W28 H45

## Accessories

FA00ALL Large cooking Lid  
 FA00ATH Paper Towel Holder  
 FA00ACT Ceramic Tray Set  
 FA00ABB Beverage Bucket  
 FA00ASP Spice/Accessory Jars (8)  
 FA02AOC Outdoor Cover  
 FA2EAFP Flat Plate

**Warranty:** All grills are covered by a one (1) year comprehensive parts and labor warranty. In addition, a five (5) year limited parts warranty covers specific parts by model.

A lifetime warranty covers all stainless steel components against manufacture related defects. This excludes discoloration or surface corrosion resulting from improper use and care. Please refer to user manual for proper care and maintenance.

Specifications are subject to change without notice. Please call 888.88.FUEGO or check our website at [www.fuegoliving.com](http://www.fuegoliving.com) for potential specification updates.

Fuego North America Roundhouse One, 1500 Sansome Street, #100, San Francisco, CA 94111

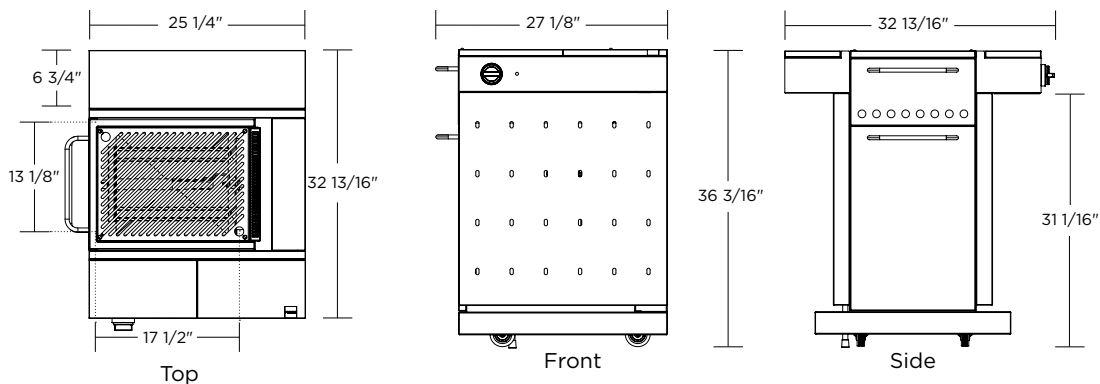

**FUEGO**

®



## **Fuego Modular Outdoor Kitchen**

Big and bold with enough mass appeal to wow a crowd, the award-winning Fuego Modular delivers a fully customized outdoor kitchen with room to grow. It can be configured any way you want—freestanding or mounted—with separate stainless steel modules for grilling, warming, storing, cooling, washing, and gawking.

# Specifications

## A. Storage Unit (model - FM20ASU)

### Color

Commercial Grade Stainless Steel exterior, black powder coated steel interior.

### Features

19" Storage Module  
Large Drawer (propane or interchangeable drawer storage)  
3/4" Teak Countertop

## B. Grill Unit w/ Gas Interchangeable Drawer (model - FM20AGU)

### Color

Commercial Grade Stainless Steel exterior, black powder coated steel interior.

### Features

Patented Quick Change Drawer System  
Lower Sliding Storage Drawer  
4" Cooking Lid  
Built in Residue Tray  
Battery Ignition

### SS Gas Burner

18,500 btu/hr

### Burner Options (sold as accessory)

Charcoal Interchangeable Drawer (FA20ACD)  
Infrared Interchangeable Drawer (FA20AID)

### Grilling Area

468 sq. in

### Grill Grates

Cast Iron, enamel coated

### Controls

Infinite Control knobs

## C. Grill Unit w/ Infrared Interchangeable Drawer (model - FM20AIU)

### Color

Commercial Grade Stainless Steel exterior, black powder coated steel interior.

### Features

Patented Quick Change Drawer System  
Lower Sliding Storage Drawer  
4" Cooking Lid  
Built in Residue Tray  
Battery Ignition

### Infrared Gas Burner

18,500 btu/hr

### Burner Options (sold as accessory)

Charcoal Interchangeable Drawer (FA20AID)  
Gas Interchangeable Drawer (FA20AGD)

### Grilling Area

468 sq. in

### Grill Grates

Cast Iron, enamel coated

### Controls

Infinite Control knobs

## D. Cook Unit (model - FM20ACU)

### Color

Commercial Grade Stainless Steel exterior, black powder coated steel interior.

### Features

Dual sealed gas burners  
Lower Sliding Storage Drawer  
4" Cooking Lid  
Built in Residue Tray  
Battery Ignition

### Gas Burner

2 @ 12,000 btu/hr

### Controls

Infinite Control knobs

## E. Warm Unit (model - FM20AWU)

### Color

Commercial Grade Stainless Steel exterior, black powder coated steel interior.

### Features

Upper Storage Drawer  
Lower Sterno fueled warming drawer (Fuel not included)  
4 chafing pans with lids  
3/4" Slate countertop

## F. Mounting Unit - Dining

### Color

Aluminum

### Free-standing Island configuration

### Features

(2) 8'4" L Mounting Beams (FM20AMBI/FM20AMB2)  
(3) 39 3/4" H Counter Legs (FM20AML)

## G. Dining Unit Counter Top (FA20ADC)

### Material

Dark gray natural basalt stone

## H. Light Unit (model - FM20ALU)

### Color

Aluminum

### Features

Aluminum light frame  
(3) Directional Halogen Lights (MR16)  
110 volts

## I/J. End Panels (FM20BEP/FM20AEP)

End panel without light (FM20AEP)

End panel with light (either left or right side) (FM20BEP)

## K-O Utility Unit

### Color

Commercial Grade Stainless Steel exterior, black powder coated steel interior.

### Features

K. Utility Unit Frame (FM20AUFR/FM20AUFS)  
L. (2) Storage Cabinets (Model# FM20AUS)  
M. Utility Unit countertop, dark gray basalt stone, (FA 20AUC)  
N. Stainless Steel Sink (FA20ASS)  
O. Faucet (FA20AUF)  
Modular Accessory System  
Leveling Legs  
Junction Box Cutout

### Optional Features/Dealer Options (sold separately)

24" Double Drawer Refrigeration Unit

Overlay kits are available for select under counter refrigeration models.

Custom counter top templates available at [www.fuegolving.com](http://www.fuegolving.com)

## Utility Unit Diagram

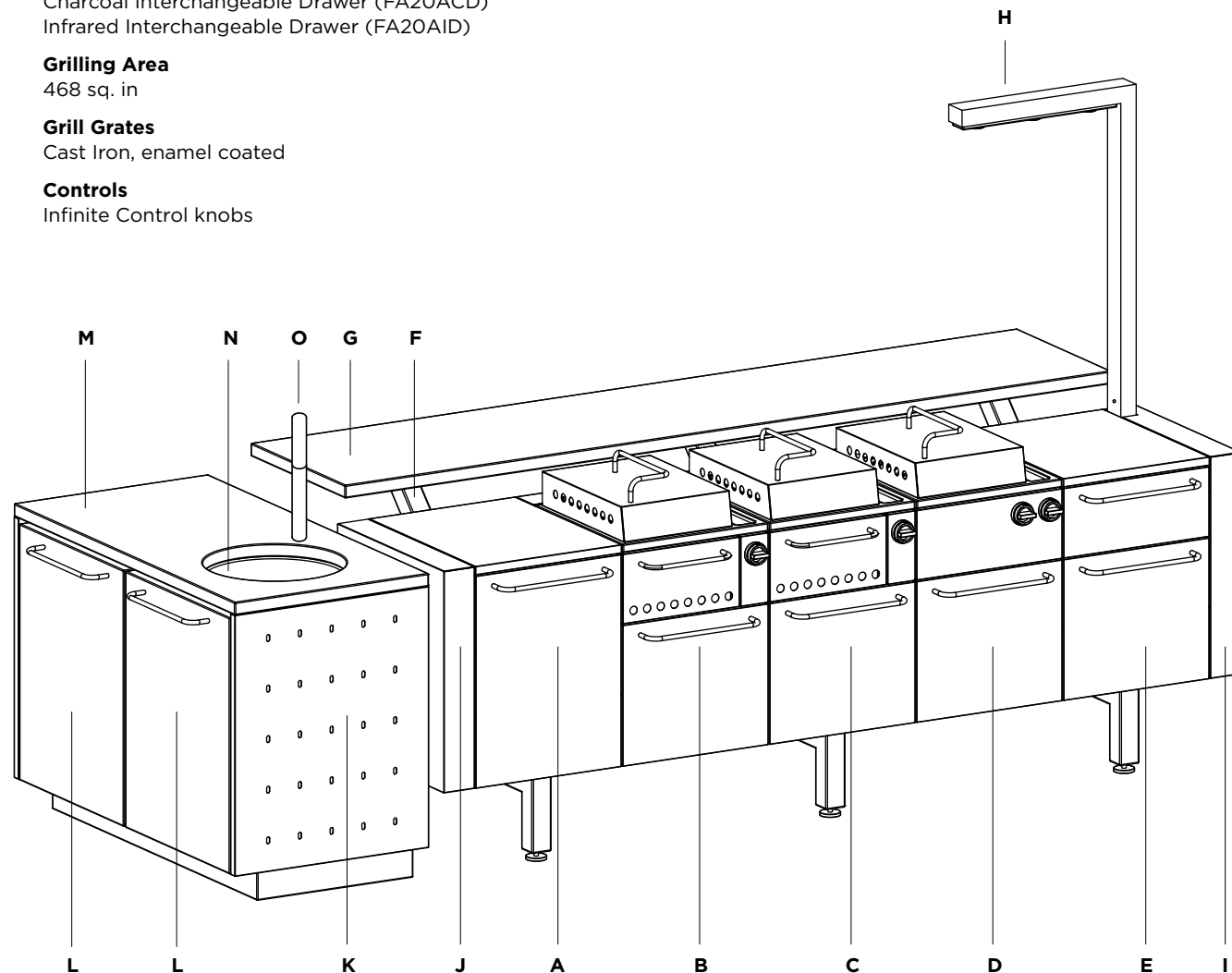
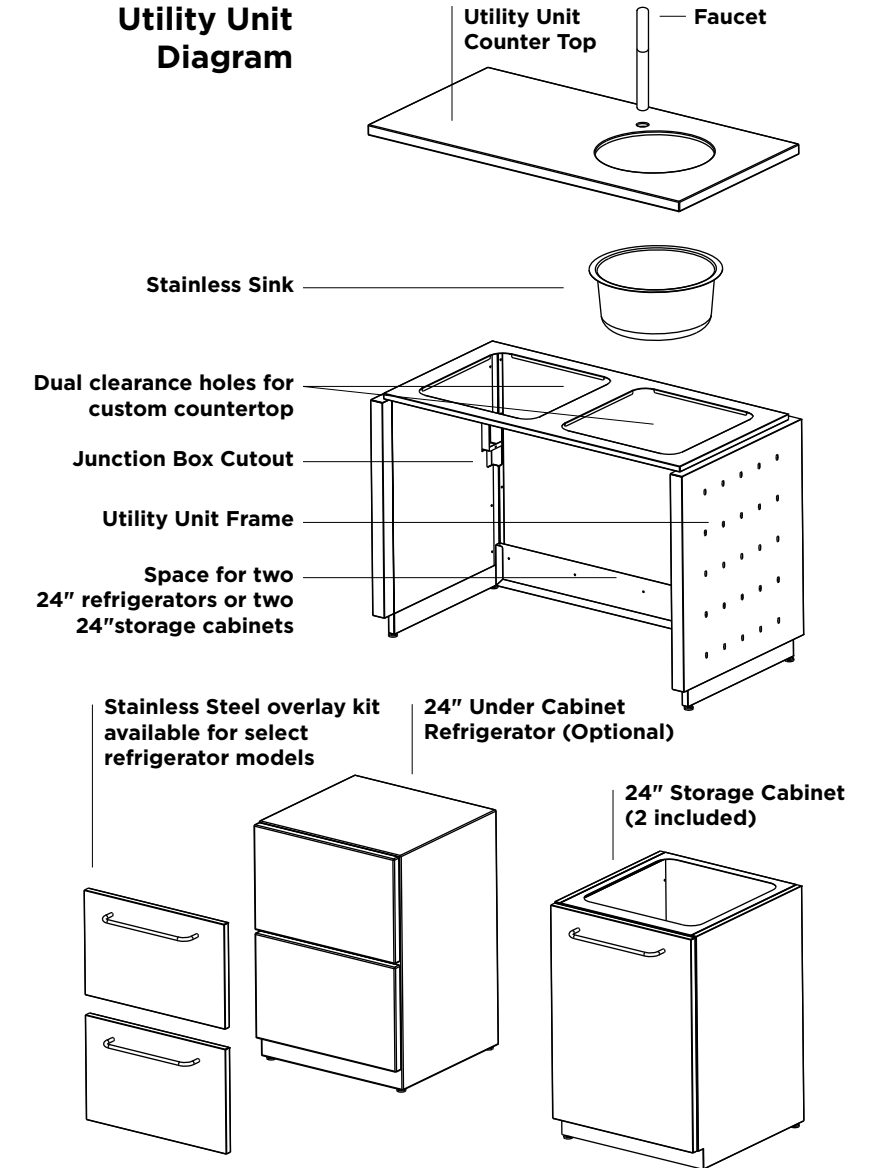



## Gas Requirements

### Natural

Modular comes standard with NG connection.

### Propane

A separate LP kit is available.

## Accessories (sold separately)

- FA20ACD Charcoal Drawer Option
- FA20AID Infrared Drawer Option
- FA20AGD Gas Drawer Option
- FA00ATH Paper Towel Holder
- FA00ACT Ceramic Tray Set
- FA00ASP Spice Accessory Jars (8)
- FA00ABB Beverage Bucket
- FA00AGP Griddle/Flat Plate
- FA00ALL 7" Large Cooking Lid
- FA20ALP LP Conversion Kit

## Warranty

All modules are covered by a one (1) year comprehensive parts and labor warranty. In addition, a five (5) year limited parts warranty covers specific parts by model.

A limited lifetime warranty covers all stainless steel components against manufacturer related defects. This excludes discoloration or surface corrosion resulting from improper use and care. Please refer to user manual for proper care and maintenance.

Specifications are subject to change without notice. Please call 888.88.FUEGO or check our website at [www.fuegoliving.com](http://www.fuegoliving.com) for potential specification updates.

Fuego North America Roundhouse One, 1500 Sansome Street #100, San Francisco, CA, 94111

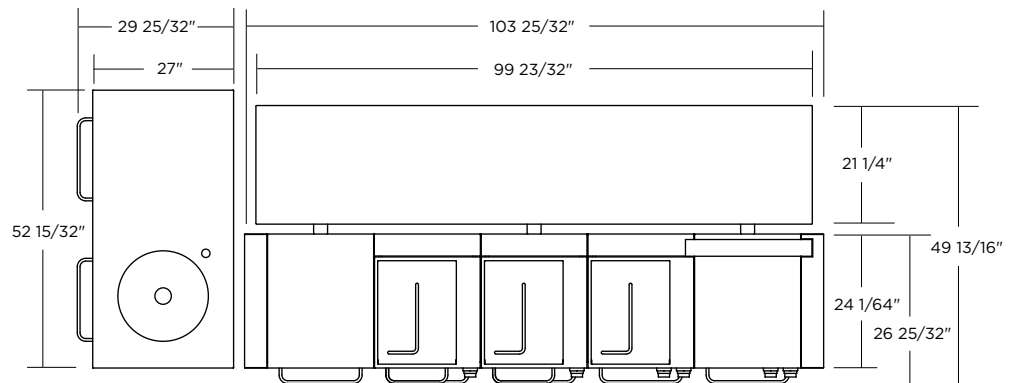

Top

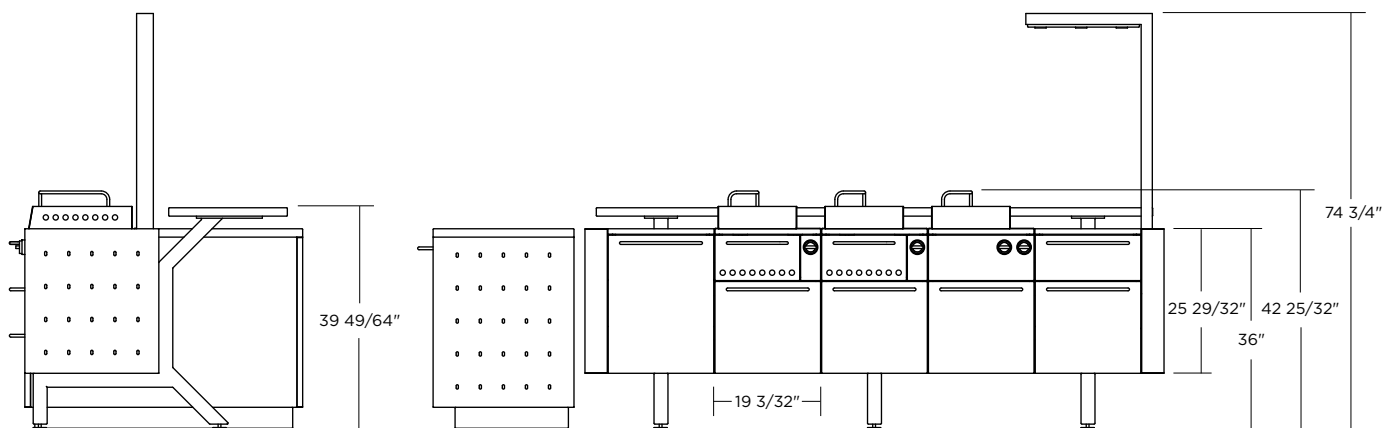

Side

Front

