

SMARTTEC Technologies



**ENGLISH
USER MANUAL**

NOVO Controller

HV3013-4 and HV4413-3

VERSION: 07.6

For any information, kindly send an email to :
us.support@smartectechnologies.com

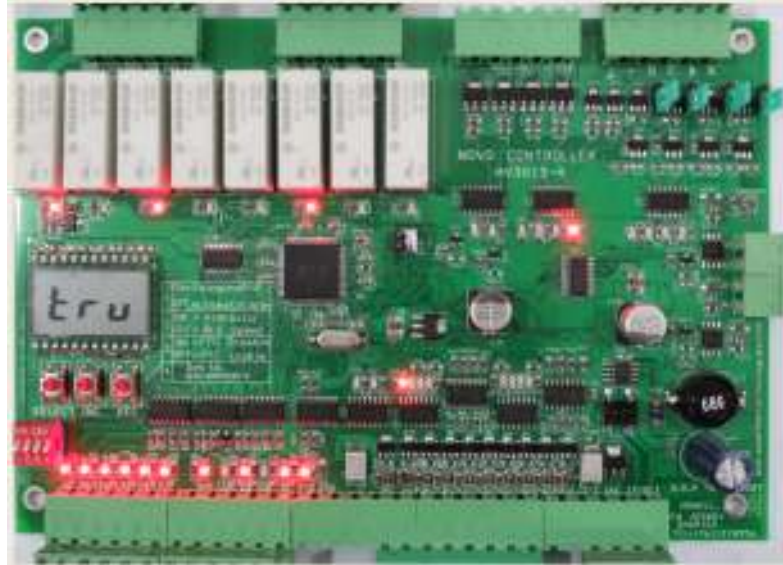

The information contained in this document is the proprietary information of **Smartec Technologies**. The contents are confidential and any disclosure to persons other than the officers, employees, agents or subcontractors of the owner or licensee of this document, without the prior written consent of **Smartec Technologies**, is strictly prohibited.

Further, no portion of this publication may be reproduced, stored in a retrieval system, or transmitted in any form or by any means, electronic or mechanical, including photocopying and recording, without the prior written consent of **Smartec Technologies**, the copyright holder.

Smartec Technologies publishes this manual without making any warranty as to the content contained herein. Further **Smartec Technologies** reserves the right to make modifications, additions and deletions to this manual due to typographical errors, inaccurate information, or improvements to programs and/or equipment at any time and without notice. Such change will, nevertheless be incorporated into new editions of this manual.

All rights reserved.

© **SMARTEC** Technologies 2014-3-17

Publication number: MNH 224 1876 R1A

MNH 224 1876 R1A

NOVO BOARD Elevator Control System

Can be up to 5 floors down collective in a single board,
and 10 stops down collective in serial communication.

SMARTEC Technologies specializes in the design and production of high technology electronic products. Today's electronic product development requires the skillful blend of expert hardware and software engineering together with a spirit of creativity and innovation, tempered by the practical concerns of manufacturability, cost consciousness, testability and on-time delivery. With hundreds of successful project completions, Smartec is uniquely suited to engineer your concept into reality. **Smartec** will work with your idea, perform detailed design, construct prototype units, refine the prototype design and manufacture your electronic product. Fast accurately, on time and on budget.

General Description:

NOVO Board Elevator Control System is a state-of-the-art high-speed Microcomputer based elevator control system that continuously collects and evaluates traffic demand patterns for each individual elevator car and the entire elevator system. Based on real time events when compared to predicted traffic conditions and anticipated system demands, the **NOVO** Board Elevator Control System automatically modifies its dispatching parameters to optimize system operation.

Individual elements of the **NOVO** Board Elevator Control System (Group Supervisory Panel, Car Control System, Motion Control System and Drive Control System) were created to interface in a cohesive manner to provide an elevator system with unmatched ride quality characteristics while exceeding the most stringent performance requirements.

NOVO Board Group Supervisory Panel Operating under standard serial communications protocol, the **NOVO** Board Group Supervisory Panel constantly monitors and analyzes changing traffic demands to predict the future movement of the entire elevator system and to create a real time traffic pattern scenario. Based in part on the following factors: (a) elevator status, (b) elevator direction of travel and hoist way position, (c) hall call assignments, (d) car call patterns, (e) door position, (f) stopping parameters, and (g) systems conditions, the **NOVO** Board Group Supervisory Panel automatically recognizes any fluctuations in traffic conditions and immediately adjusts the system operation.

Combining real time conditions, historical traffic patterns and predicted system demand, the **NOVO** Board Group Supervisory Control System continually creates an arrival time prediction diagram for each elevator car and constantly calculates the shortest waiting time when making a hall call assignment.

NOVO Board Car Control System Utilizing sophisticated **Smartec's** Microcomputer technology and advanced distributed controller design concepts, the **NOVO** Board Car Control System uses a distributed control network to provide an extremely powerful and incredibly flexible elevator control system. Operating under the Plug And Play® communications protocol (interconnected communication via high-speed serial data links), the **NOVO** Board Car Control System continuously distributes control to specific sections of the elevator car (elevator car top, elevator car operating panel, elevator hall fixtures, etc.) to provide superior system performance.

Alpha –numeric view on the LCD display

0	0	A	A	K	K	U	U
1	1	B	B	L	L	V	V
2	2	C	C	M	M	W	W
3	3	D	D	N	N	X	X
4	4	E	E	O	O	Y	Y
5	5	F	F	P	P	Z	Z
6	6	G	G	Q	Q		
7	7	H	H	R	R		
8	8	I	I	S	S		
9	9	J	J	T	T		

Main features

Platform Type	Risk processor Single – Dual Speed - VVVF – Hydraulic
Mode	Single (1Board) - Serial(2Boards)
Fault Capture	Display more than 200 fault messages
Status information	Status of the elevator, door, mode and Limit switch Up &Down are displayed
Fault count	Counts and saves the number and code of errors that occur
Shaft information	End of the Shaft in the Up and Down Direction Slow down in the final stop in Up and Down Direction Level Zone Elevator position is saved at each stop
Indicator signal	Gray, Binary, and 7- Segment
Number of Stops	5(down collective),10(down collective in serial mode)
Door Type	Swinging, Automatic and ½ Automatic
Door Controls	3 input for control: Clse circ / Door E.C / and Door E.O
Floor Stop Time	Can specify time of stopping at each floor
Car Light	Light timer
Home Floor timer	Automatic Return to Home floor after preset time
Inspection Mode	Elevator goes to inspection/service mode
Drop Out	Cancels all the outside calls
No Load	At preset floor, it will cancel all the inside calls if the door was closed
Full Load	The elevator will not serve the out side calls
Emergency Stop	It will stop immediately and cancel all inside calls
Fireman Operation	It will cancel all calls and go to Fireman floor

SUMMARY

1. BOARD DESCRIPTION	PAGE
1.1 BOARD LAYOUT	7
1.2 INPUT TERMINALS	7
1.3 CALL TERMINALS	8
1.4 OUTPUT TERMINALS for AC2 speed and VVVF	8
1.5 INDICATOR OUTPUT TERMINALS	9
2. DIP SWITCH and PUSH BUTTONS	9
2.1 DIP SWITCHES FUNCTIONS	9
2.2 PUSH BUTTONS FUNCTIONS	10
3. LCD SCREEN DISPLAY	10
3.1 How to enter the ERROR PAGE	11
3.2 ERROR LIST DESCRIPTION AND SOLUTION	11
3.3 How to enter the PARAMETER PAGE	12
3.4 LIST OF PARAMETERS.....	13
3.5 TO CHANGE A PARAMETER VALUE	16
3.6 TO EXIT AND LEAVE THE PARAMETERS LIST.....	16
4. Speed table for FUJI Inverter	17
5. Controller Connections	18
5.1 TERMINAL'S POSITIONS ON THE BOARD	19
5.2 INPUT CONNECTIONS	19
5.3 CALL CONNECTIONS	20
5.3.1 <u>5-stops down collective</u>	20
5.4 INDICATOR CONNECTIONS	20
5.5 RELAY OUTPUT CONNECTIONS	22
6. WIRINGS	23
6.1 <u>10-STOPS Down-collective</u> (Serial mode)	24
6.2 <u>10-STOPS None-collective</u> (Simplex mode)	25
6.3 <u>10-STOPS Down-collective</u> (Switching mode)	26
6.4 <u>10-STOPS Full-collective</u> (same inside outside calls)	27
6.5 <u>USING (+60 VDC) CONTACTOR with SAFETY CIRCUIT</u>	28
6.6 <u>USING (110 VAC) CONTACTOR with SAFETY CIRCUIT</u>	29
6.7 <u>2 SPEED VVVF DRIVE</u>	30
6.8 <u>AUTOMATIC/ MANUAL DOOR VVVF</u>	31
6.9 <u>AUTOMATIC /MANUAL DOOR AC2 speed</u>	32
6.11 <u>Door Type</u>	33
7. MAGNETIC SENSORS' DISPOSITION	34

1. BOARD DESCRIPTION

1.1 BOARD LAYOUT

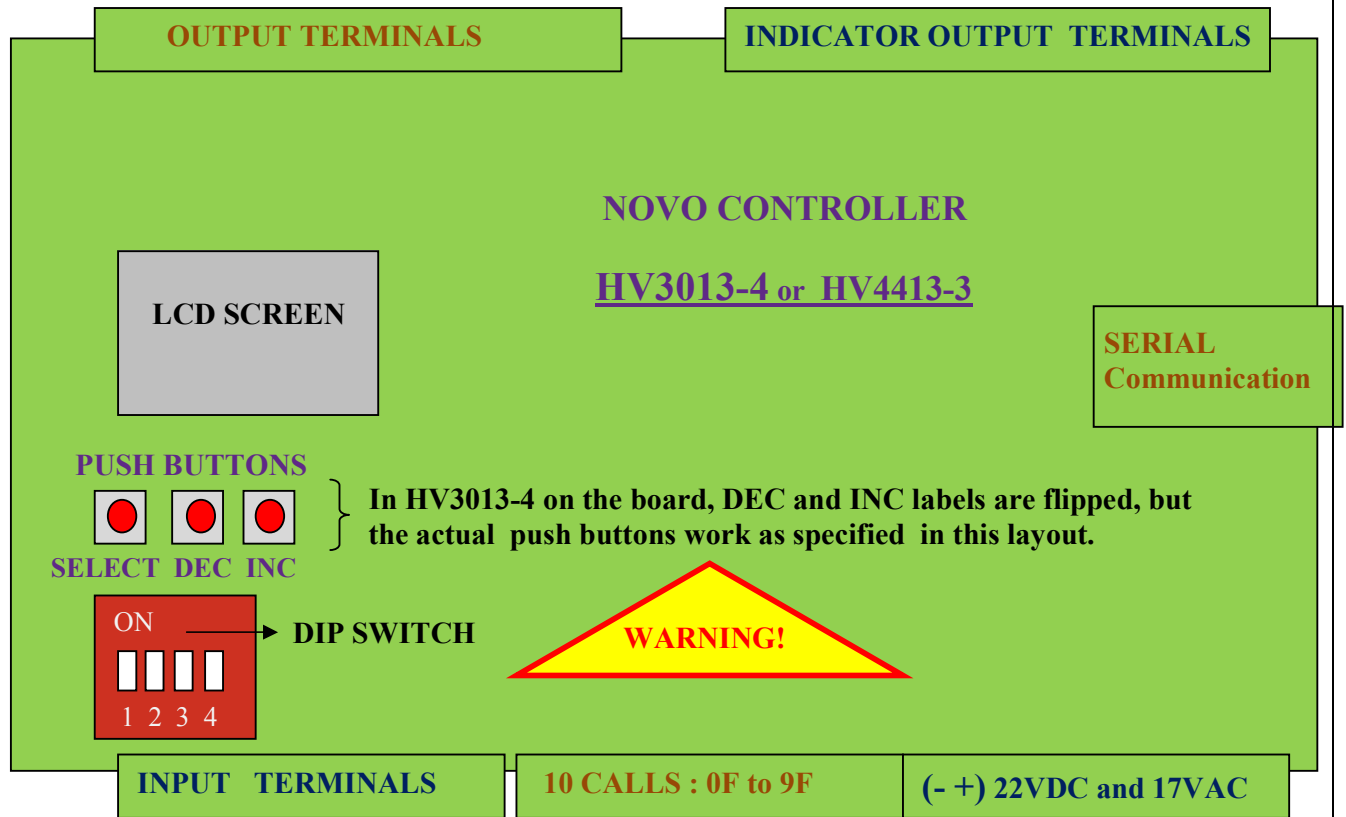

1.2 INPUT TERMINALS

UP	Magnetic switch Up direction
DN	Magnetic switch Down direction
LSUP	Limit switch Up direction
LSDN	Limit switch Down direction
SEN	Service enable
STP	Emergency Stop/ Fireman
XON	Auxiliary ON contactor for UP/DN direction
Clse Circ	Bypasses reclosing delay for automatic door/ defines the door status for swinging door , if its LED on the board is on= close, off=open
Door E.C	Limit switch end of closing
Door E.O	Limit switch end of opening
Last Fl/ RSV	Reserve
PTC	Motor PTC

SUP	Service UP is CALL 1F in Inspection mode
SDN	Service DOWN is CALL 0F in Inspection mode
17 VAC	Board power supply = 17vac

1.3 CALL TERMINALS

0F	Floor 0 call
1F	Floor 1 call
2F	Floor 2 call
3F	Floor 3 call
4F	Floor 4 call
5F	Floor 5call
6F	Floor 6 call
7F	Floor 7 call
8F	Floor 8 call
9F	Floor 9 call

1.4 OUTPUT TERMINALS for AC2 speed and VVVF

(-) 22 V	Biasing voltage from periphery supply –negative side ⁽¹⁾
(+) 22V	Biasing voltage from periphery supply – positive side ⁽¹⁾
CLSE CAM	Cam contactor ⁽³⁾ / Close relay or contactor ⁽²⁾
OPN	Open door relay or contactor ⁽²⁾
CM2	Common 2 for CLSE CAM and OPN
HI	High speed contactor
LOW	Low speed contactor
DOWN	Down direction contactor
UP	Up direction contactor
SPR	Spare output
CM1	Common 1 for HI, LOW,UP, DOWN, and SPARE
LITE	Car light relay
COM LITE	Common for LITE output

⁽¹⁾: Although this is not an output, it is listed with the outputs for convenience

⁽²⁾ : For automatic door only

⁽³⁾ : For swinging door

1.5 INDICATOR OUTPUT TERMINALS

A	Floor information A
B	Floor information B
C	Floor information C
D	Floor information D
↑	Arrow UP
↓	Arrow Down
CAR +	Reserved for switching mode and 7-segment display
CAR -	Reserved for switching mode and 7-segment display
HALL +	Reserved for switching mode and 7-segment display
HALL -	Reserved for switching mode and 7-segment display

2. DIP SWITCH and PUSH BUTTONS

2.1 Dip switches functions

The functions specified by switches 1,2 and 3 can only take place if **switch 4 is OFF**.

Otherwise, if **switch 4 is ON**, the functions' positions of switches 1,2 and 3 will be ignored, and the value specified in their parameters' list will take place.

Switch 1 is in parameter **P02**, (Check section 3.5 for parameters' settings)

Switch 2 is in parameter **P045**, and switch 3 is in parameter **P022**

DIP SWITCHES 1,2, and 3 are activated for a quick way of setting some functions without the need of setting them in the parameters list

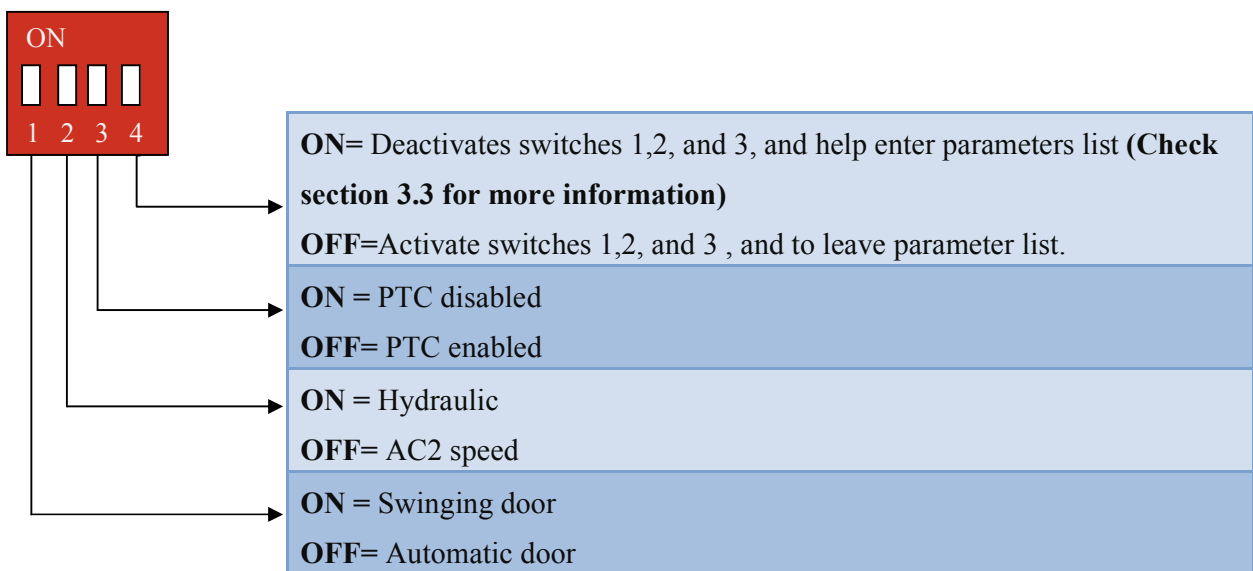

2.2 PUSH BUTTONS FUNCTIONS

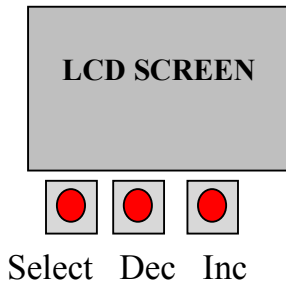

Inc= Increment. To increase a parameter value or scroll up in parameters or pages in increasing order

Dec= Decrement. To decrease a parameter value or scroll down in parameters or pages in decreasing order

Select= To enter a parameter value and save it

3. LCD SCREEN DISPLAY

When the NOVO controller is powered up (17VAC),

The **mode** of the elevator will appear on the screen: (**Inspection , travel, or stop mode**)

According to the wirings that were made on the NOVO controller

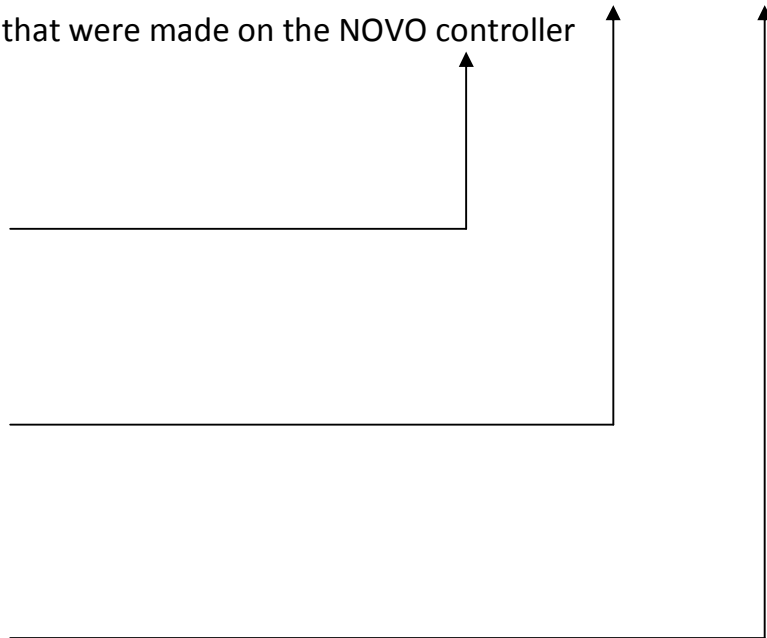
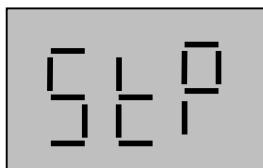
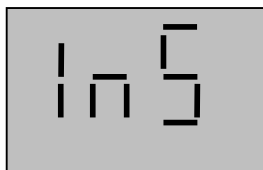

3.1 How to enter the **ERROR PAGE**

Once you are in the main screen (not in parameter's list)
Click **DEC** button and the **ERROR PAGE** will be entered

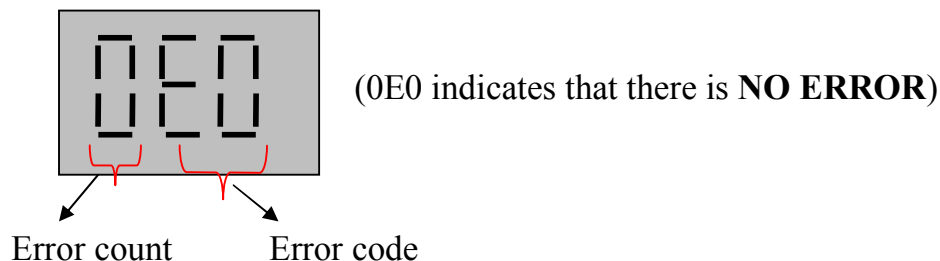

Use **DEC** or **INC** to scroll between the error codes, if more than 1 error occurred.

3.2 ERROR LIST DESCRIPTION AND SOLUTION

Error Displayed on LCD	Description	Controller Action	Solution
xE1	Motor powered but car didn't move	Block	Check the Brake or Pins, Turn electricity off then on.
x11	Missed Pulses.	Reset and make home trip	Check the pins or magnet.
xE2	Limit switch Up fault	Block	Check Switch up, Turn electricity off then on.
xE3	Limit switch Down fault	Block	Check Switch down, Turn electricity off then on.
xE4	Limit switch up & Down fault	Block	Check Switch up & Down, Turn electricity off then on.
xE5	Gamma fail in contactor up	Cancel calls	Check Gamma
xE6	Yale is opened	Cancel calls	Check Yale
x12	Door Lock circuit open during travel	Wait for lock circuit, Cancel calls if fault persists more than 5 sec	Check Yale
x14	Safety and Ready circuits are open	Waits for Ready circuit to close	Check Aux Nc or Yale
x13	Count days of operation expired	Block	Contact the System Administrator.
x10	Stop key Error	Complete cycle	Check Stop Key.
xE7	PTC overheating. Motor Temperature exceeds limits.	Elevator will not take calls after the first stops.	Wait for motor to cool Or disable PTC.

Error Displayed on LCD	Description	Controller Action	Solution
xE9	End of closing automatic door	Door Blocked	Check auto door limit switch
x15	Drive error	VVVF error	Check VVVF
xEb	Block	-	-
xEn	unlock	-	-

Where “x” is the ERROR count.

For example:

0E0 : No Error

1E2 : First error is limit switch up. 2Eb : Second Error is Block.

NOVO Controller is capable of storing 9 errors on the LCD screen.

To leave ERROR List: Click the **SELECT** button to go to main page.

3.3 How to enter the **PARAMETER** page

Once the NOVO board is powered up with 17VAC, **click dip switch 4 ON**, to be able to open the parameters page.(If dip switch 4 is OFF, you cannot enter the parameters page)

Click the **SELECT** push button, and the **first parameter P01** will appear on the screen.

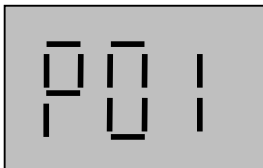

If you click the **INC** button you will jump to parameter **P02** and so on to scroll between parameters in **increasing order**.

If you click the **DEC** button, you will scroll between the parameters in **decreasing order**.

There are 59 parameters, from P01 to P59. The end of the list specified as:

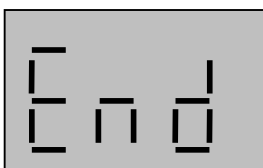

3.4 LIST OF PARAMETERS

Parameter Number	Parameter Description on LCD	Parameter Full Description	Parameter Value(default)	Value Range
P01	<u>Floor Stopping Time</u>	Time between travels in sec.	3	1 → 15 sec
P02	<u>DOOR TYPE</u>	Selects the type of the elevator door. Selects ½ automatic door if there is an electric cam to lock the door in addition to the automatic door drive. (Swinging / Automatic / Semi Automatic)	0	0= Swinging 1= Automatic 2=Semi-automatic (not available, do not use)
P03	<u>LEVEL ZONE</u>	Level of each floor	0	0=None 1=Installed NC 2=Installed NO
P04	<u>MAX. COUNT OF ERR</u>	Sets the maximum count of Level II faults before blocking the elevator	0	1 → 254
P05	<u>BASEMENTS</u>	Sets the number of basements	0	0 → 9
P06	<u>HOME FLOOR</u>	Floor of which station is on.	0	0→9
P07	<u>HOME FLOOR TIMER</u>	Time out to go to home floor.	0	1 → 180 sec
P08	<u>NO LOAD</u>	In case of swinging; if door is not open after certain number of calls, the elevator will cancel all inside calls. Example: value=2 and 5 inside calls has been pressed than people left the elevator. The controller will service 2 stops. In case of automatic: if nothing crossed the photocell, the elevator will cancel all inside calls.	0	0 → 9
P09	<u>COLLECTIVE</u>	Selects between collective selective and down collective modes (Full / Down)	1	0=Full, 1=Down
P10	<u>HOMING ON POWER</u>	When enabled, the elevator makes a homing trip upon every power-on	1	0= Disable, 1=Enable
P11	<u>TRUNCATE</u>	Empty the fault log.	0	0
AUTOMATIC DOOR				
P12	<u>OPN/ CLS DOOR TIME</u>	The Time of the open or close.	6	5→31 sec
P13	<u>Parking Door</u>	The parking status of the door	0	0=Close, 1= Open
P15	<u>LIGHT TIME</u>	Cabin light timer.	5	1 →60sec
SECONDARY				
P16	<u>KEEP CLOSE</u>	Keep door active during travel.	0	0=Disable, 1=Enable
P17	<u>RETRY GAMMA:</u>	Only for swinging door	3	3 → 10 time
P18	<u>RETRY GAMMA TIMER</u>	Gamma retry timer.	3	3 → 30 sec
P20	<u>PULSE TIME OUT</u>	After the magnet time out has passed then the elevator will block	20	1 → 99 sec
P21	<u>YAL TIMER</u>	Disconnect safety circuit time-out to cancel all calls	5	1 → 60 sec
P22	<u>PTC-NTC / PRE-RLS</u>		0	0=PTC, 2=NTC

P23	<u>FIREMAN FLOOR</u>	Programming stop input (check table 3.4.1 for more information)	stp	STP=stop floor F0→F9 ,fireman floor number Ful=full load Drp=Drop out lvl=level zone cls= close delay
P24	<u>FLOOR EXPANSION</u>	(check table 3.4.2 for more information)	16	16,17,64,96,128
P26	<u>INDICATOR TYPE</u>		0	0=Gray, 1= Binary , 2= 7-segment
P30	<u>LMT SW DURING INS</u>		1	0=Disable, 1=Enable
P31	<u>COUNT OF DAYS</u>		0	0→254 days
P36	<u>FIRMWARE VERSION</u>			769
HYDRAULIC AND VVVF ELEVATOR				
P37	<u>VVVF/HYD STOP DELAY</u>	The delay in sec between removing direction and speed reference outputs VVVF selected with speed reference disengaging before direction.	0	0 →50 sec
P38	<u>VVVF START DELAY</u>	The delay in sec between providing direction and speed reference outputs VVVF selected with speed reference disengaging before direction	0	0 →30 sec
P41	<u>SPARE2OUTPUT</u>	Used as output brake in VVVF only	1	0=brake,1=inspection
P42	<u>Hydraulic start time</u>			0→99 msec
P44	<u>PASSENGER CAPACITY</u>		0	0 → 15
P45	<u>DRIVE / VVVF TYPE</u>		0	0=AC2 Speed, 1=VVVF ABB 2= Hydraulic, 3=VVVF standard 4=VVVF 3 speed 5=VVVF Fuji 6=VVVF Fuji 3 speed
P47	<u>BOARD TYPE</u>	Choose board type for serial communication	0	0=none 1=cabin 2=panel
P48	<u>Input Value</u>	For technician use. To light the seven segment strips according to their input value		
P52	<u>First stop</u>	Selects the gray code output for first stop	0	0→1
P53	<u>Dual Door Entrance</u>	Selection mode for dual door opening on certain floors. check section 3.4.3	Dis	Dis= Disable EnA=Enable 0,1,2,3,0-1,0-2,1-2
P59	<u>RESTORE DEFAULT</u>	Click select to restore all default values with either: “dec” to restore all values to swinging mode or “inc” to restore all values to automatic mode		EAS=Exit, Auto, Swing

3.4.1:

NOVO board has **2 programmable inputs (RSV and STP)**

It can be programmed by changing a value of P23 (see the table below)

CODE	DESCRIPTION	USE
STP	Stop floor	Click the button to stop the car
Fx	x= from 0 to 9	Click the button to stop at one certain floor from F0 to F9 for fireman emergency
Ful	Full load	Stop the car when there is over-capacity
Drp	Drop out	Cancel all outside calls
lvl	Level zone	Level the car in the correct position in case there were missed pulses
cls	Close delay	To close the door

3.4.2: Choosing P24 according to certain floor expansion

CODE	Description
16	Up to 5 stops down collective
17	Up to 10 stops down collective (SWITCHING mode)
64	Up to 10 stops none collective (SIMPLEX (+) mode) , when travelling down, only takes 1 outside call going down as long as it is below the position of the car. If you want to go to GND floor, and floor 2 for example requested a down travel, the car will stop at 2 and continue down travel.
96	Up to 10 stops none collective (SIMPLEX normal mode)
128	Up to 10 stops full collective BUT! Inside and outside calls are the same (connected to each other)

You can check the wiring diagrams in section 6

3.4.3: Dual door entrance

Dual doors can be programmed by **P53** to open one of the dual doors inside the elevator car from GF to 3rd floor.

CONNECTIONS FOR THE 2ND DOOR :

-Close and Open **OUTPUTS** : **Door Open = CAR (+) , Door Close= Hall (+)**

-Close and Open **INPUTS** : **Door E.C= Last fl. or RSV , Door E.O= STP**

3.5 TO CHANGE A PARAMETER VALUE:

Once you are in a certain parameter, for example P04, click **SELECT**, and the default value of P04, which is 0 (checking the table), will appear on the screen.

To change this value you can either click **DEC or INC** to scroll in the range of possible values for this parameter in increasing or decreasing order.

When you reach the value you want, click **SELECT** to choose and save that value for the parameter, and you will be back in the parameters list.

3.6 TO EXIT AND LEAVE THE PARAMETERS LIST:

To leave the parameters list and go back to the main page you can either:

1. Clicking **dip switch 4 OFF** will leave the parameters list and go back to main page

(You can click 4 ON again if you don't want to active switches 1 ,2 and 3)

2. Once you are in the parameters list, keep scrolling the parameter list with **DEC or INC** until you reach the **END** of the list:

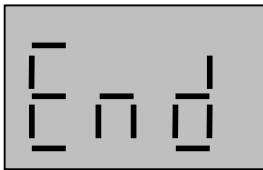

Then click the **SELECT** button to exit to main page, where the mode appears (Section 3).

4. Speed table for FUJI inverters

Use **P38** parameter for VVVF start delay, where (UP or Down) direction logic is set ON, it will delay to set (HI, Spare or Low **in the table below**) to ON

Use **P37** parameter for VVVF stop delay, where (HI, Spare, or Low) are ON, it will delay to set (UP or Down) to OFF

Put P45 = 5. For FUJI VVVF 2-speed:

Speed Ref	UP	Down	HI	LOW	Spare	CAR(-)	Relays of NOVO controller
	FWD	REV	(X3)	(X2)	(X1)	Enable inverter	Connections on Fuji drive
Zero speed (0000)	OFF	OFF	OFF	OFF	OFF	OFF	
Intermediate speed 1 UP (10001)	ON	OFF	OFF	ON	ON	ON	
Intermediate speed 1 DN (01001)	OFF	ON	OFF	ON	ON	ON	
Inspection speed UP (10010)	ON	OFF	OFF	OFF	ON	ON	
Inspection speed DN (01010)	OFF	ON	OFF	OFF	ON	ON	
High speed UP (10111)	ON	OFF	ON	OFF	OFF	ON	
High speed DN (01111)	OFF	ON	ON	OFF	OFF	ON	

Put P45 = 6. For VVVF 3-speed:

Speed Ref	UP	Down	HI	LOW	Spare	CAR(-)	Relays of NOVO controller
	FWD	REV	(X3)	(X2)	(X1)	Enable inverter	Connections on Fuji drive
Zero speed (0000)	OFF	OFF	OFF	OFF	OFF	OFF	
Intermediate speed 1 UP (10001)	ON	OFF	OFF	ON	ON	ON	
Intermediate speed 1 DN (01001)	OFF	ON	OFF	ON	ON	ON	
Inspection speed UP (10010)	ON	OFF	OFF	OFF	ON	ON	
Inspection speed DN (01010)	OFF	ON	OFF	OFF	ON	ON	
Intermediate speed 2 UP (10100)	ON	OFF	ON	OFF	OFF	ON	
Intermediate speed 2 DN (01100)	OFF	ON	ON	OFF	OFF	ON	
High speed UP (10111)	ON	OFF	ON	ON	ON	ON	
High speed DN (01111)	OFF	ON	ON	ON	ON	ON	

5. CONTROLLER CONNECTIONS

5.1 TERMINALS' POSITIONS ON THE BOARD

A2 and B2 for SERIAL CONNECTION cabin and panel board, to extend down collective stops to 10 stops

A1 and B1 are reserved for serial indicator "SMARTEC" and landing calls
 note that if you use serial indicator connection, do not use the above indicator connection "A,B,C,D,up, dn aro"

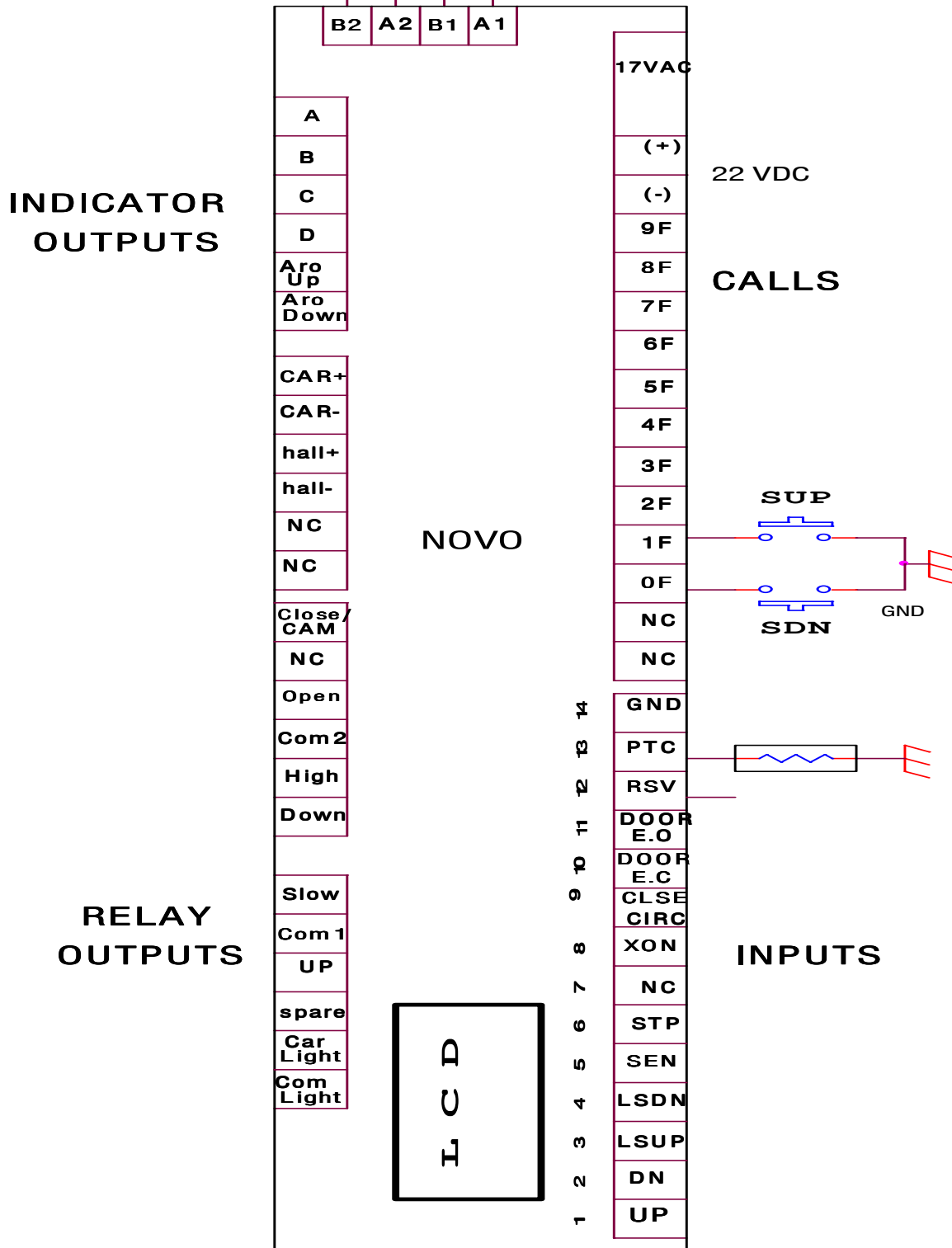

5.2 INPUT CONNECTIONS

ATTENTION!

All voltages on inputs of the controller (+22V DC) must be supplied from the same transformer.

AT NORMAL MODE, STOP STAGE (GROUND LEVEL) :

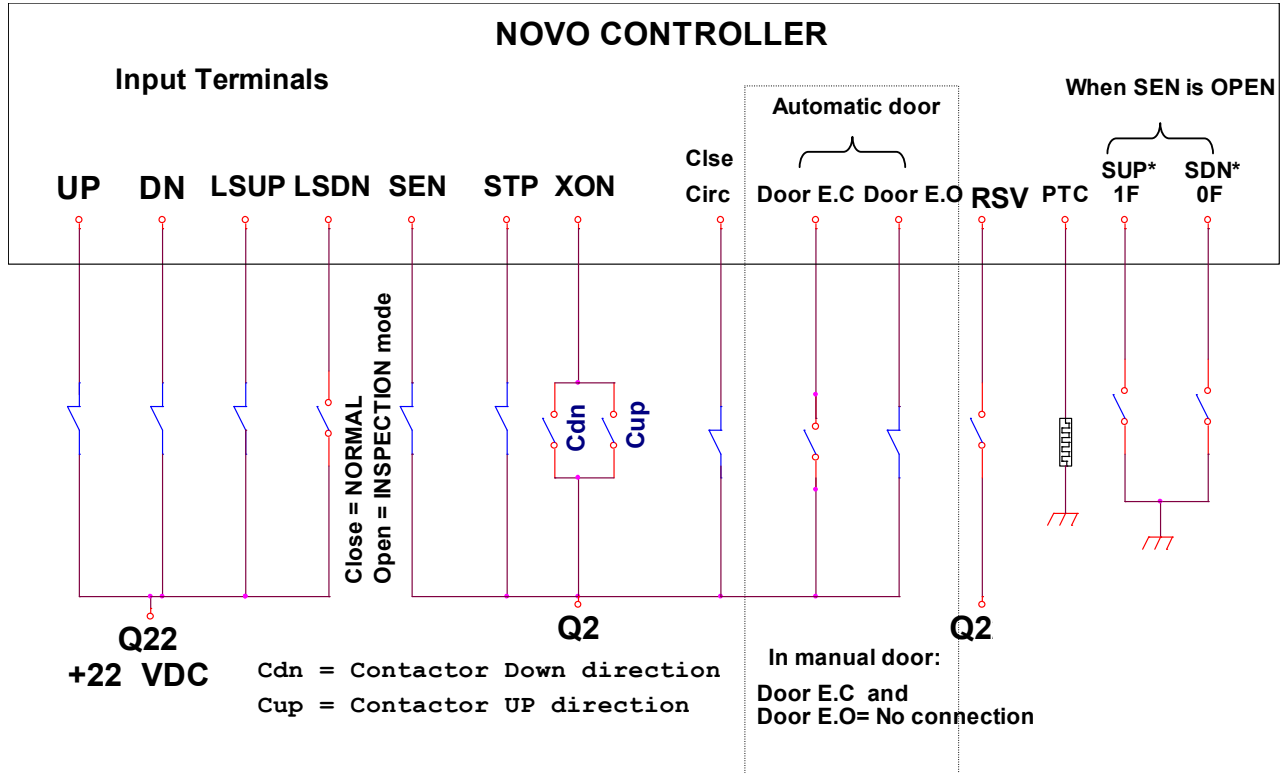

(*) These 2 inputs are service up and service down **only in inspection mode**, otherwise they are calls Where **LSDN and RSV (Last Fl.)** are normally open **N.O**
UP, DN, LSUP, and CLSE CIRC are normally close **N.C**

LED Diagram lighting for inputs in NORMAL mode (At ground level) on the board:

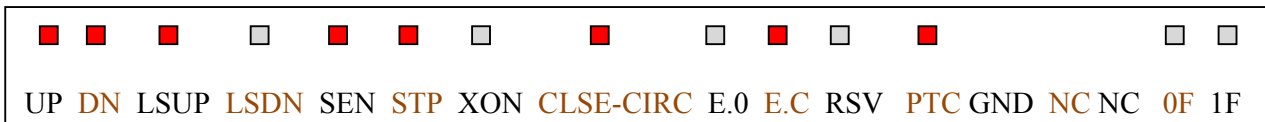

In case P22=PTC , LED is off

P22=NTC, LED is on

LED Diagram lighting for inputs in INSPECTION mode (At ground level) on the board:

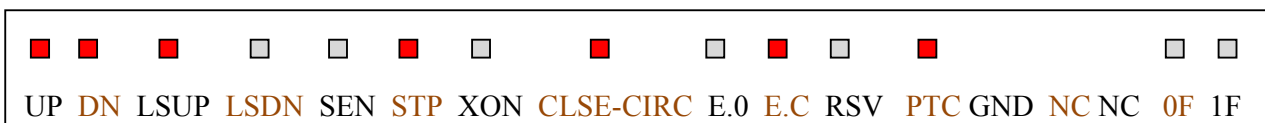

5.3 CALL CONNECTIONS

Novo board has 10 input/output pins or calls from 0F to 9F.

Their connection can be made up to **5 –stops down collective** (using 1 Novo board), or up to **10-stops down or non collective**(using 2 Novo boards in SERIAL-communication).

5.3.1 5-stops down collective

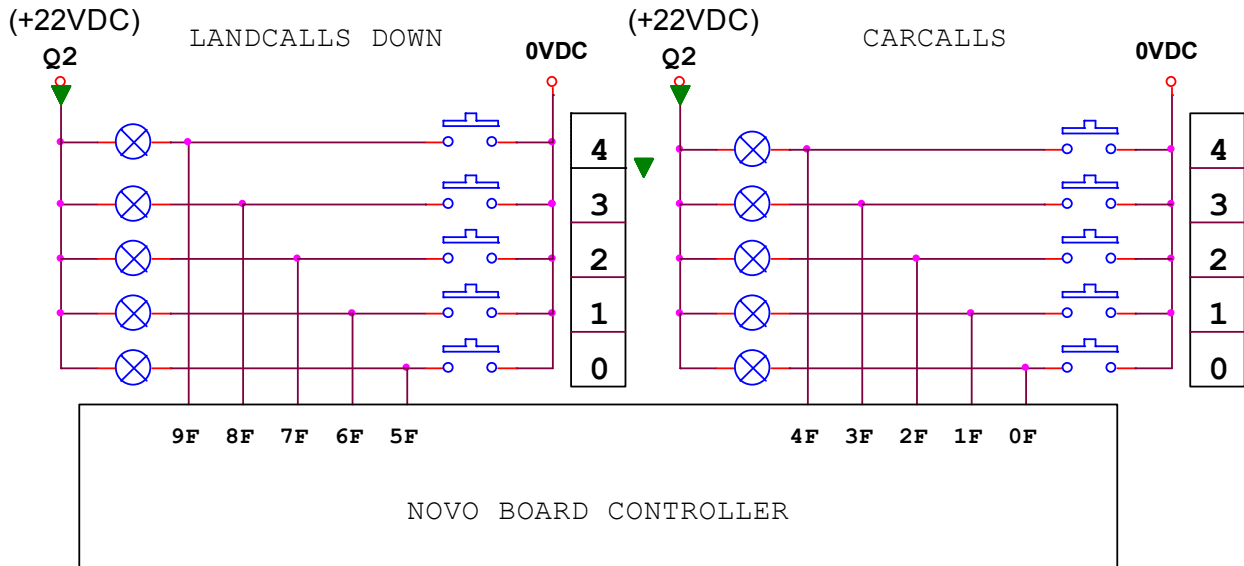

5.3.2 10-stops down collective (serial mode)

Check (page 24) for wiring diagram

5.3.3 10-stops non- collective (simplex mode)

Check (page 25) for wiring diagram

5.3.4 10-stops Down- collective (switching mode)

Check (page 26) for wiring diagram. **7-segment indicator not applicable for switching mode.**

5.3.4 10-stops Full- collective (same inside and outside calls)

Check (page 27) for wiring diagram.

5.4 INDICATOR CONNECTIONS

NOVO board has **BINARY, GRAY, and 7-Segment** indicator.

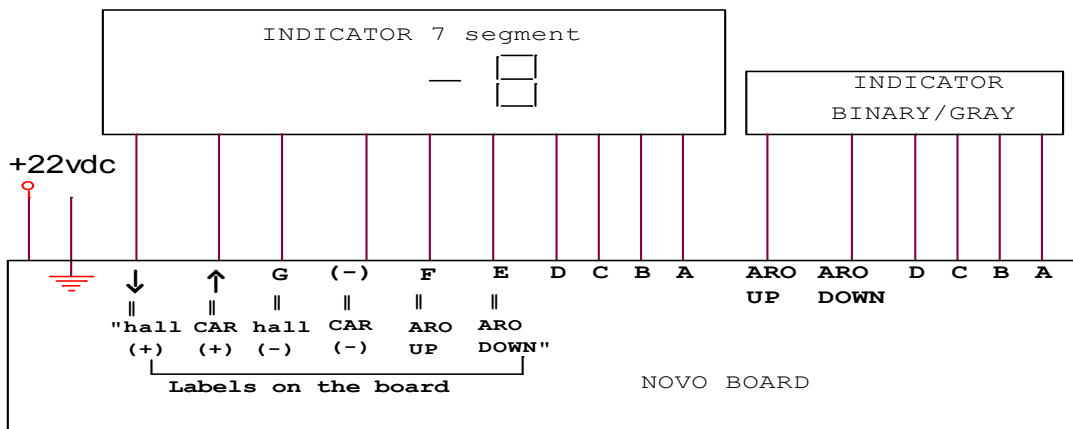

7 Segment :

A,B,C,D must be selected **ACTIVE LOW** (check jumper position in diagram 5.4.4)
ARO UP and ARO Down are **ACTIVE HIGH** always.

Binary /Gray code :

A,B,C,D can be selected either **ACTIVE LOW** or **ACTIVE HIGH**.
ARO UP and ARO DOWN are **ACTIVE LOW**

5.4.4: Changing jumper position for A, B, C and D for active high or low

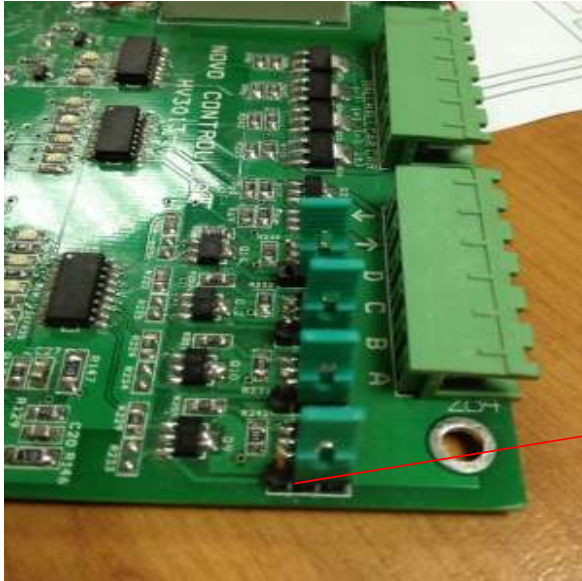

Last pin empty =Active Low



First pin empty =Active High

5.5 RELAY OUTPUT CONNECTIONS

60 VDC or 110, 220 VAC MAX

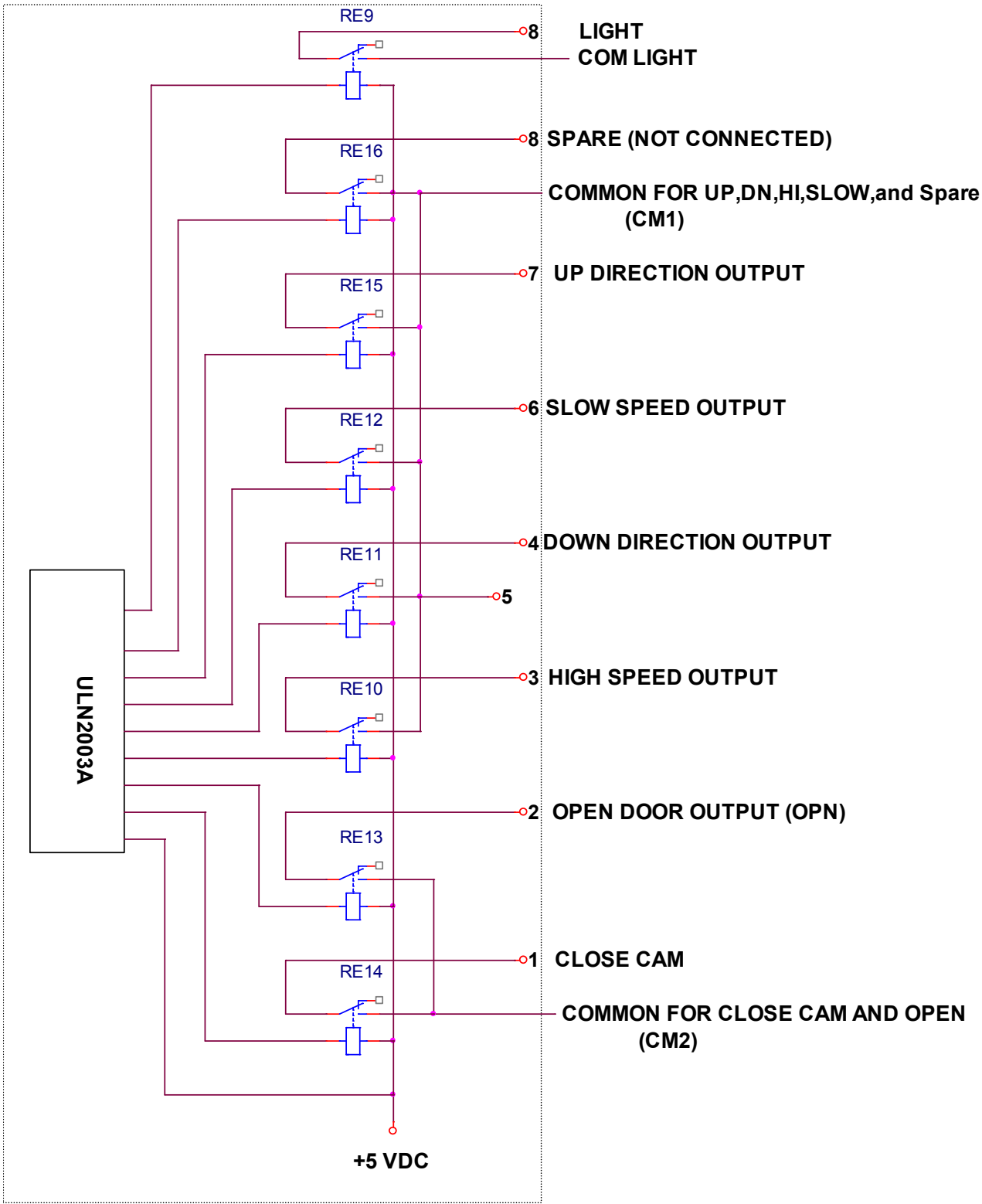

6. WIRINGS

10 STOPS DOWN COLLECTIVE SERIAL CONNECTION (2 Boards)

CABIN BOARD

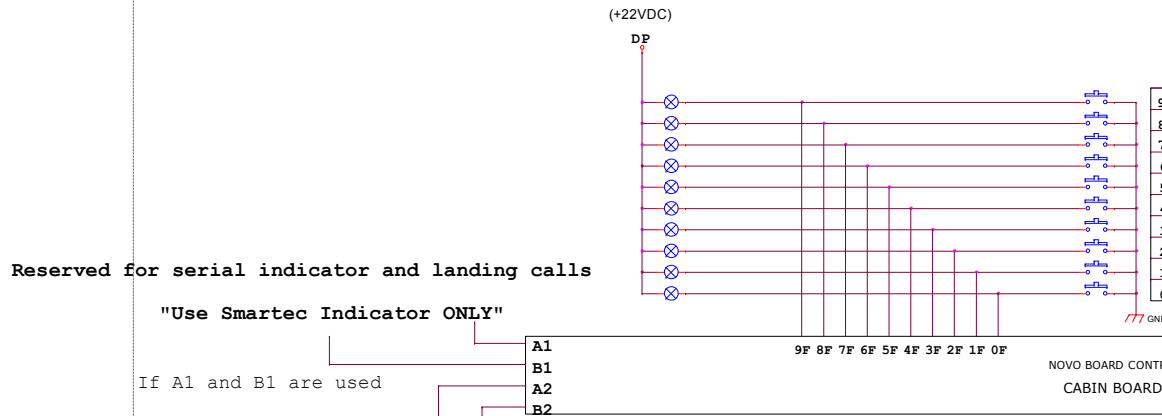

Reserved for serial indicator and landing calls

"Use Smartec Indicator ONLY"

If A1 and B1 are used

- A1
- B1
- A2
- B2

do not use A,B,C,D, aro "up and down" connections

Put P47=1 for cabin board

WIRE COUNT	Flat Cable Needed for Serial Installation
1	+ 24 VDC
1	- 24 VDC
1	A2 RS485 Serial Communication
1	B2 RS485 Serial Communication
2	For Auto/Manual Safety Line 60VDC
TOTAL WIRES	6

PANEL BOARD

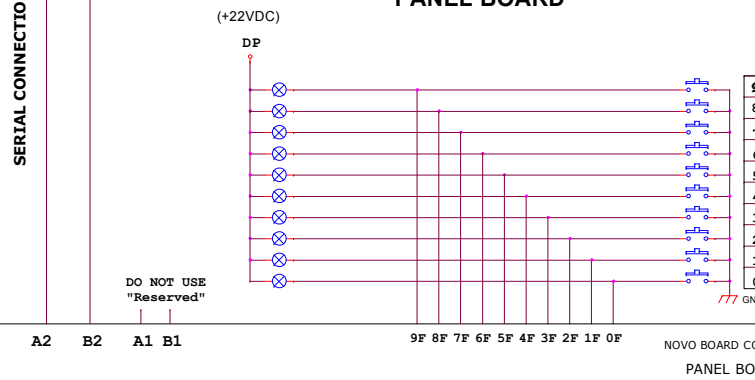

DO NOT USE
"Reserved"

- A2
- B2
- A1
- B1

Put P47=2 for panel board

WIRE COUNT	Optional wires
1	Neuter 220VAC, not required if Light 24VDC used
1	Phase 220VAC, not required if Light 24VDC used
2	For Parachute
2	Siren For Emergency
TOTAL WIRES	6

SMARTEC Technologies 55Hamdan bldg., Suite UG., Milano Rd. Beirut - Lebanon Telefax: + 961 1 278 956 www.smartectechnologies.com	page description:	project:	date: February 14, 2014
	10 STOPS DOWN COLLECTIVE SERIAL CONNECTION	NOVO BOARD CONTROLLER	page:

SIMPLEX MODE: 10 STOPS NOT COLLECTIVE

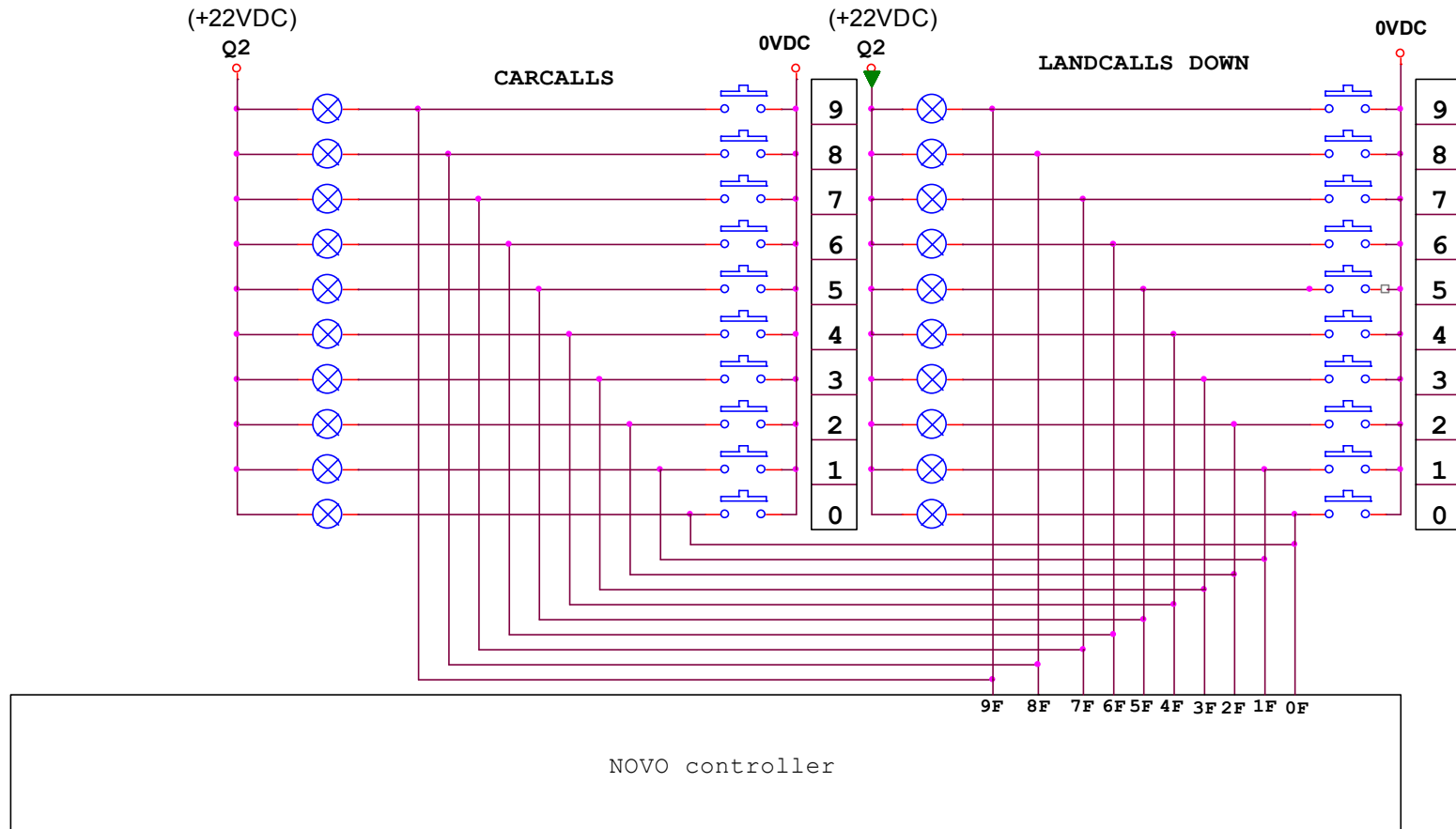

SMARTEC Technologies 55Hamdan bldg., Suite UG., Milano Rd. Beirut - Lebanon Telefax: + 961 1 278 956 www.smarttechnologies.com	page description: Simplex 10 STOPS NOT COLLECTIVE Installation	project: NOVO	date: February 17,2014
			page:

SWITCHING MODE 10 STOPS DOWN COLLECTIVE

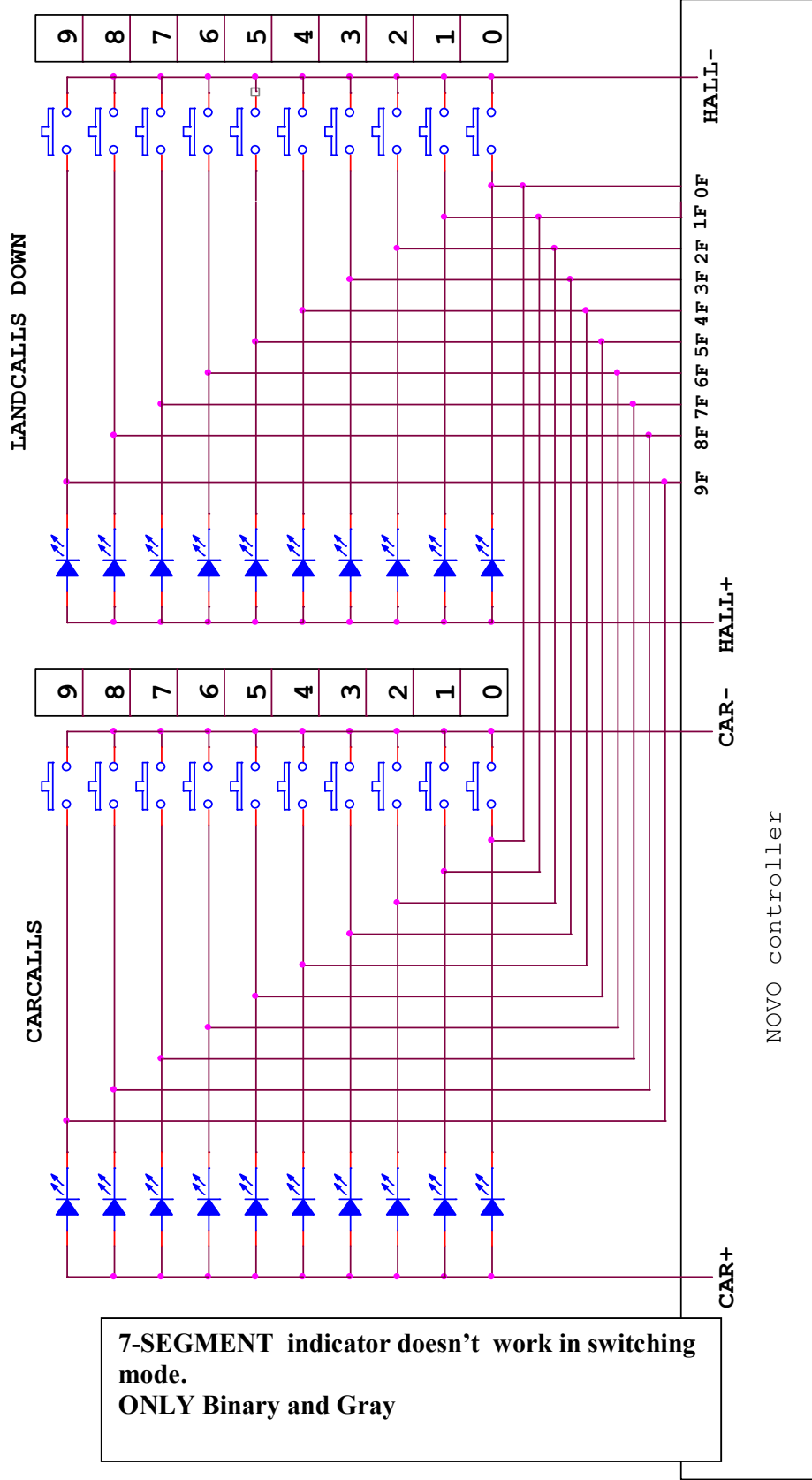

NOVO controller

<p>date: February 17, 2014</p>	<p>project: NOVO</p>
<p>page description: 10 STOPS DOWN COLLECTIVE Installation</p>	
<p>SMARTEC Technologies 55Hamdan bldg., Suite UG., Milano Rd. Beirut - Lebanon Telefax: + 961 1 278 956 www.smartecthnologies.com</p>	

10 STOPS FULL COLLECTIVE (Same inside and outside calls)

P24=128

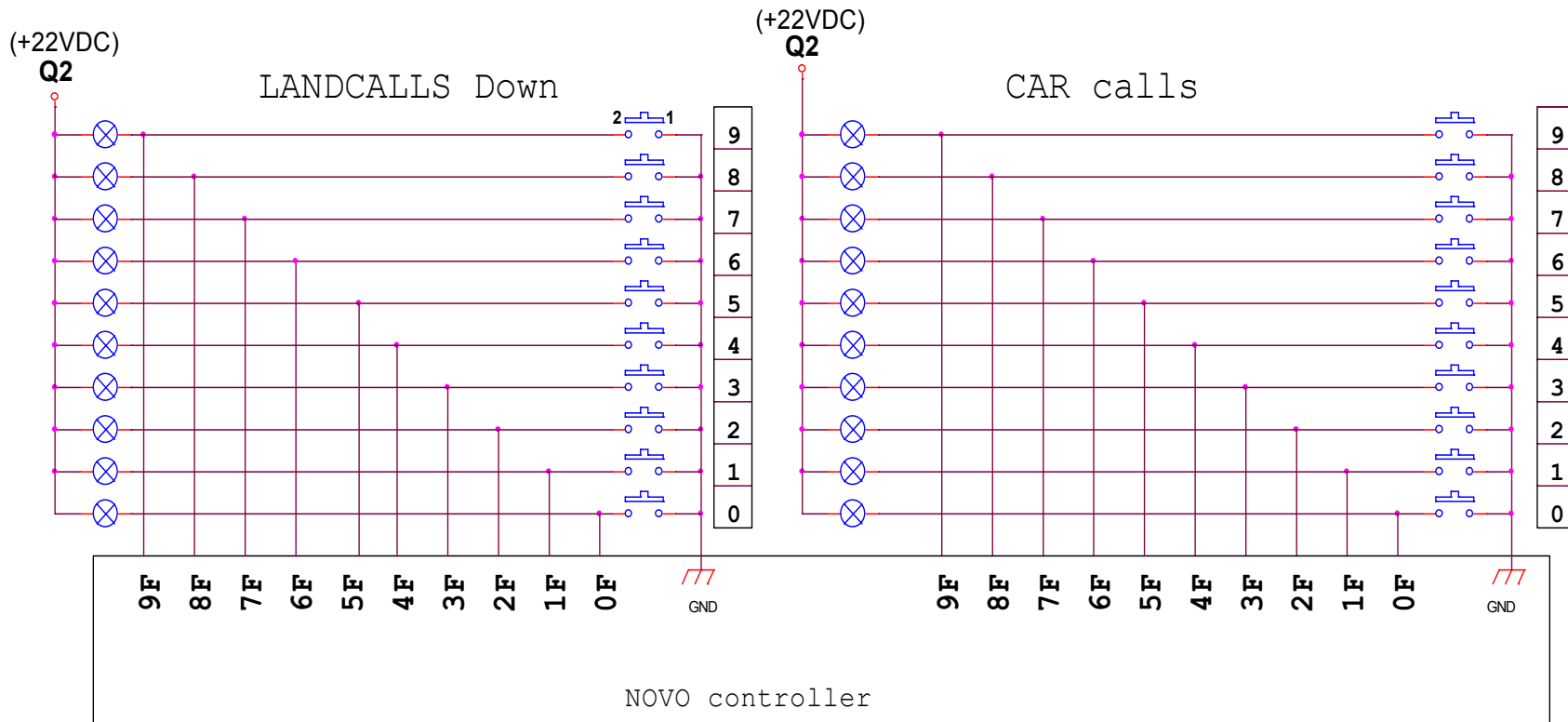

<p>SMARTEC Technologies 55Hamdan bldg., Suite UG., Milano Rd. Beirut - Lebanon Telefax: + 961 1 278 956 www.smartectechnologies.com</p>	<p>page description: 10 STOPS FULL COLLECTIVE same inside and outside calls</p>	<p>project: NOVO</p>	<p>date: March 17, 2014 <hr/> page:</p>
--	--	----------------------------------	---

USING (+60 VDC) CONTACTOR with SAFETY CIRCUIT

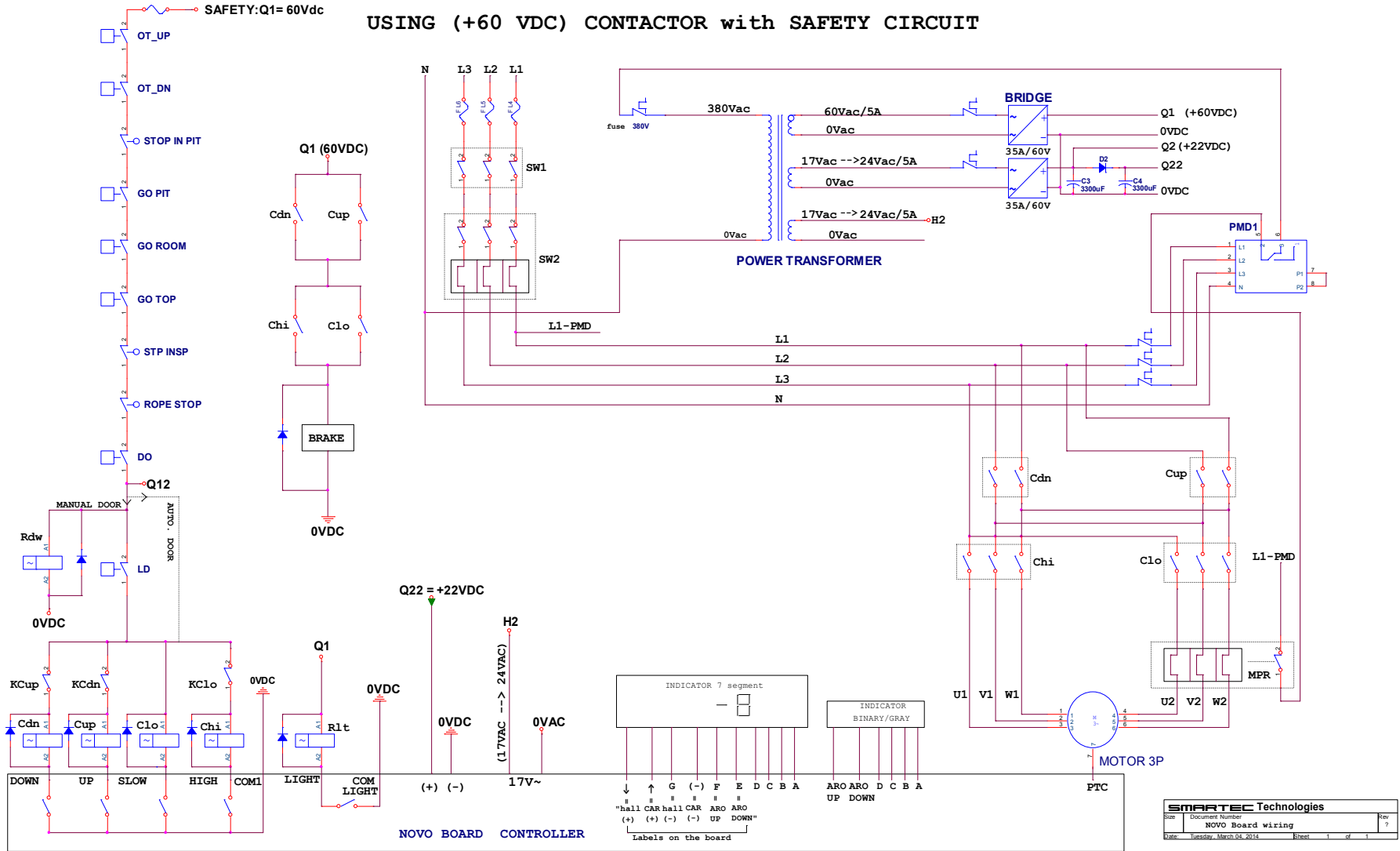

OT-UP: Over travel up mechanical limit switch
 OT-DN: Over travel down mechanical limit switch
 GO PIT: Overspeed governor pit
 GO ROOM: Overspeed governor machine room
 GO TOP: Overspeed governor top of cabine
 STP INSP: Stop inspection top of cabine

DO : Door contact mechanical switch
 LD : Door lock contact
 Rdw: Door contact relay
 KClo: Auxilliary switch for low speed contactor, should be N.C
 KCdn: Auxilliary switch for down direction contactor, should be N.C
 KCup: Auxilliary switch for up direction contactor, should be N.C

Cdn: Down direction contactor
 Cup: Up direction contactor
 Clo: Slow speed relay
 Chi: High speed relay
 Rlt: Light relay
 MPR: Motor protection relay

FMD: Phase balance and phase sequence monitoring device
 PTC: Connected to the PTC input in the EMW2.15 board
 SW1: Main circuit breaker
 SW2: Thermo-magnetic circuit breaker in control panel

SMART EC Technologies	
Doc Name	NOVO Board wiring
Date	Tuesday, March 04, 2014
Rev	1 of 1

USING (110 VAC) CONTACTOR with SAFETY CIRCUIT

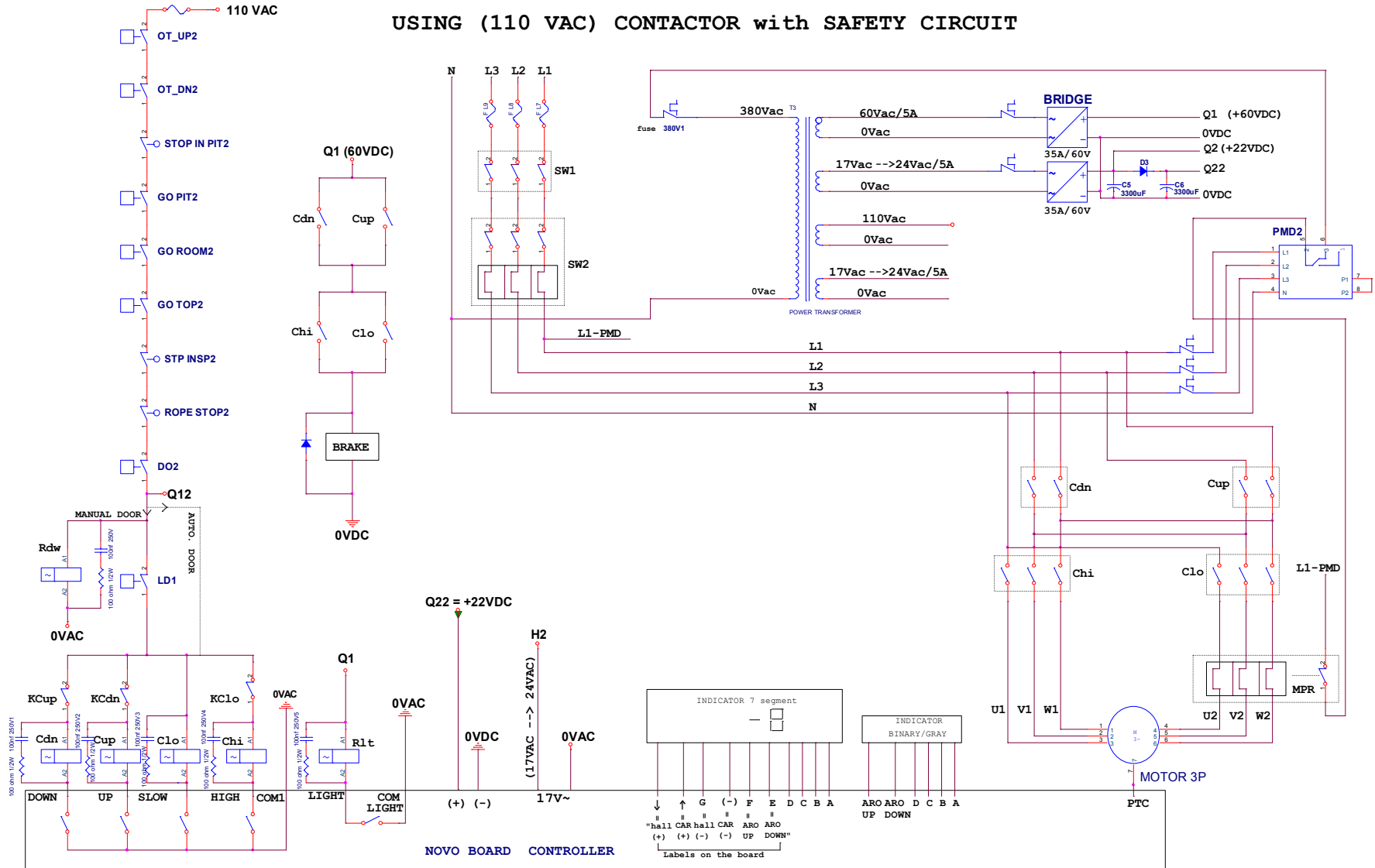

OT-UP: Over travel up mechanical limit switch
 OT-DN: Over travel down mechanical limit switch
 GO PIT: Overspeed governor pit
 GO ROOM: Overspeed governor machine room
 GO TOP: Overspeed governor top of cabine
 STP INSP: Stop inspection top of cabine

DO : Door contact mechanical switch
 LD : Door lock contact
 Rdw: Door contact relay
 KClo: Auxiliary switch for low speed contactor, should be N.C
 KCdn: Auxiliary switch for down direction contactor, should be N.C
 KCup: Auxiliary switch for up direction contactor, should be N.C

Cdn: Down direction contactor
 Cup: Up direction contactor
 Clo: Slow speed relay
 Chi: High speed relay
 Rit: Light relay
 MPR: Motor protection relay

PMD: Phase balance and phase sequence monitoring device
 PTC: Connected to the PTC input in the EMW2.15 board
 SW1: Main circuit breaker
 SW2: Thermo-magnetic circuit breaker in control panel

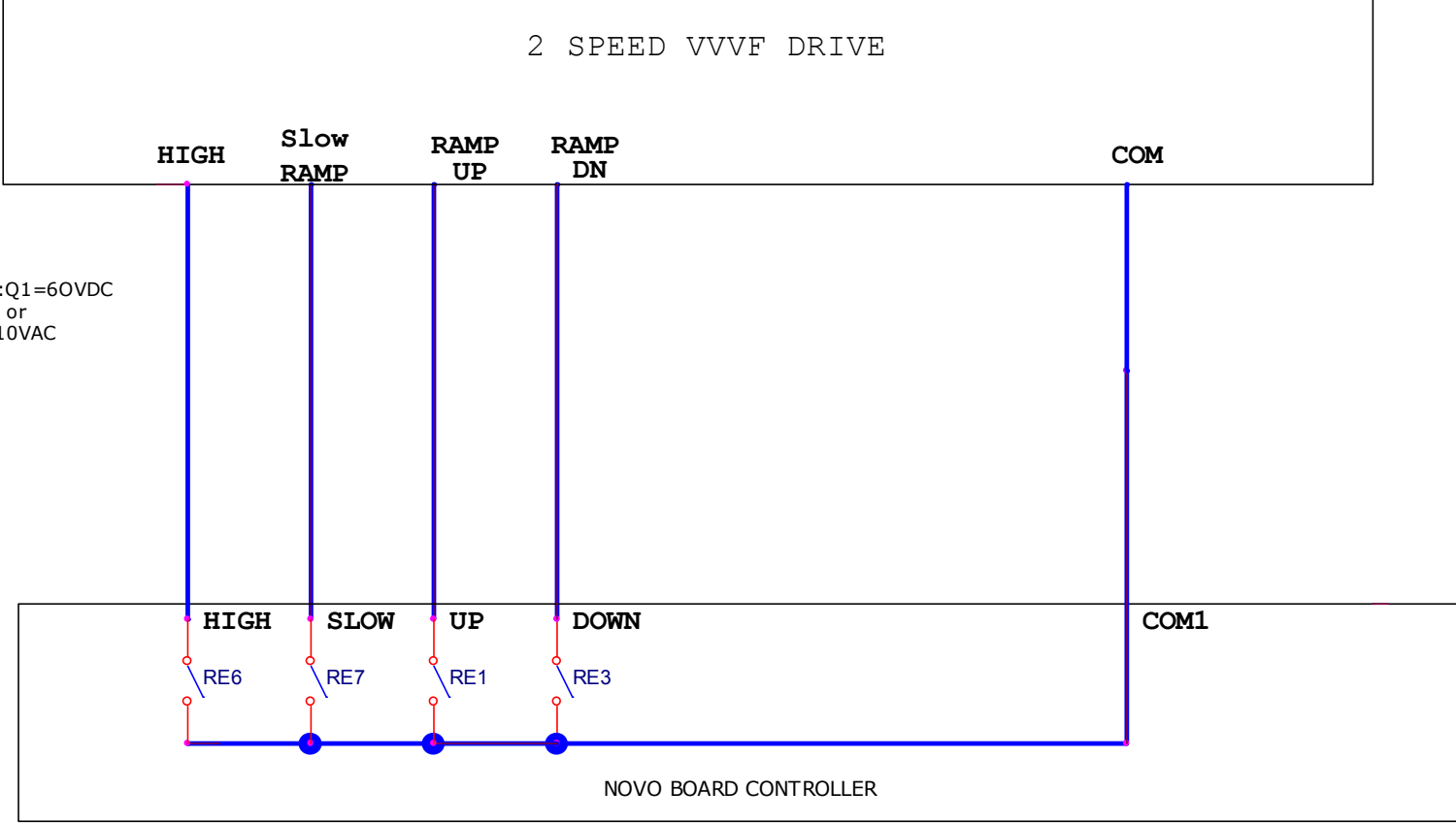

(*):do not install diodes with contactors if S1 was 110VAC

SMARTEC Technologies 55Hamdan bldg., Suite UG., Milano Rd. Beirut - Lebanon Telefax: + 961 1 278 956 www.smartectechnologies.com	page description: 2 SPEED VVVF DRIVE	project: NOVO BOARD CONTROLLER	date: February 14, 2014
			page:

AUTOMATIC/ MANUAL DOOR VVVF

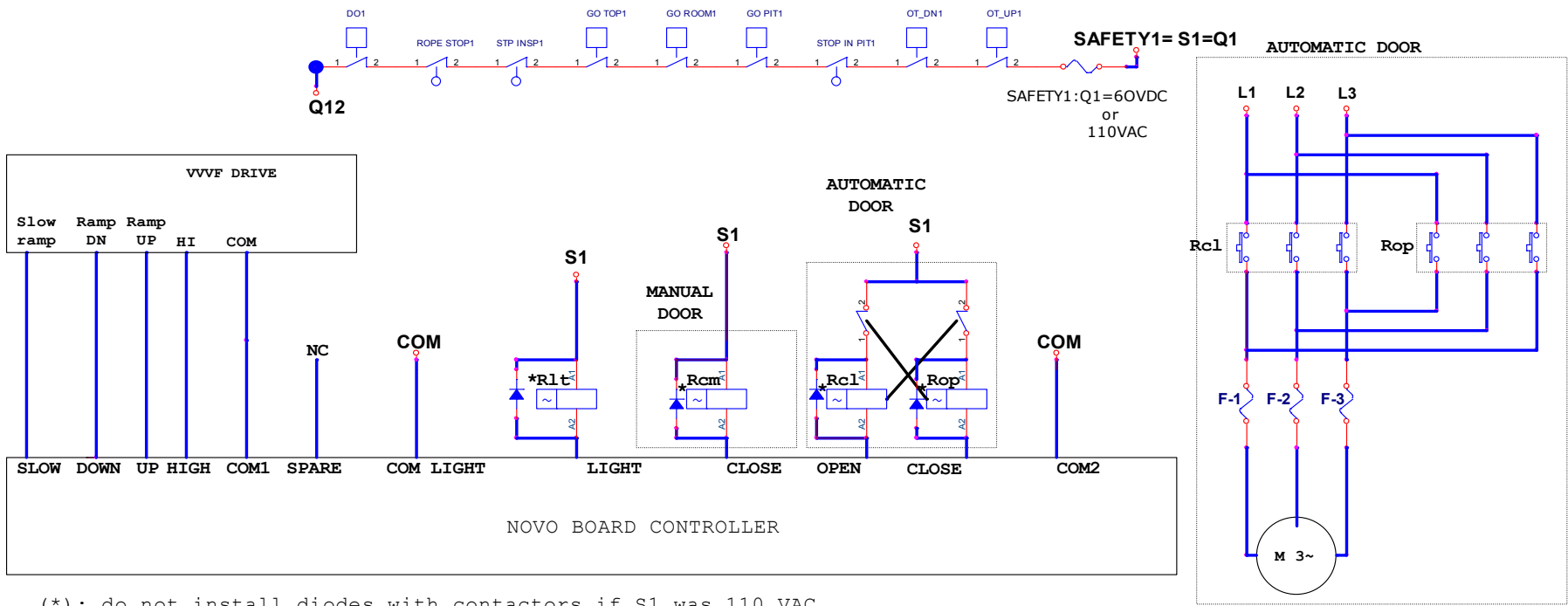

(*): do not install diodes with contactors if S1 was 110 VAC

DO :	Door contact mechanical switch	Rlt:	Light relay
STP INSP:	Stop inspection top of cabine	Rcm:	Cam relay for swinging door
GO TOP:	Overspeed governor top of cabine	Rcl:	Close door relay
GO ROOM:	Overspeed governor machine room	Rop:	Open door relay
GO PIT:	Overspeed governor pit	F-1, F2, F3:	fuses
OT-DN:	Over travel down mechanical limit switch	COM1:	Common for relay (down,up,slow,high and spare) is connected to 0VDC or 0VAC depending on the chosen (110VAC or 60VDC)
OT-UP:	Over travel up mechanical limit switch	COM2:	Common for relay (open & close) is connected to 0VDC or 0VAC
		COM LIGHT :	Common for relay car light is connected to 0VAC or 0VDC

SMARTEC Technologies 55Hamdan bldg., Suite UG., Milano Rd. Beirut - Lebanon Telefax: + 961 1 278 956 www.smartechnologies.com	page description:	project:	date:
	AUTOMATIC/ MANUAL DOOR VVVF	NOVO BOARD CONTROLLER	February 14, 2014
			page:

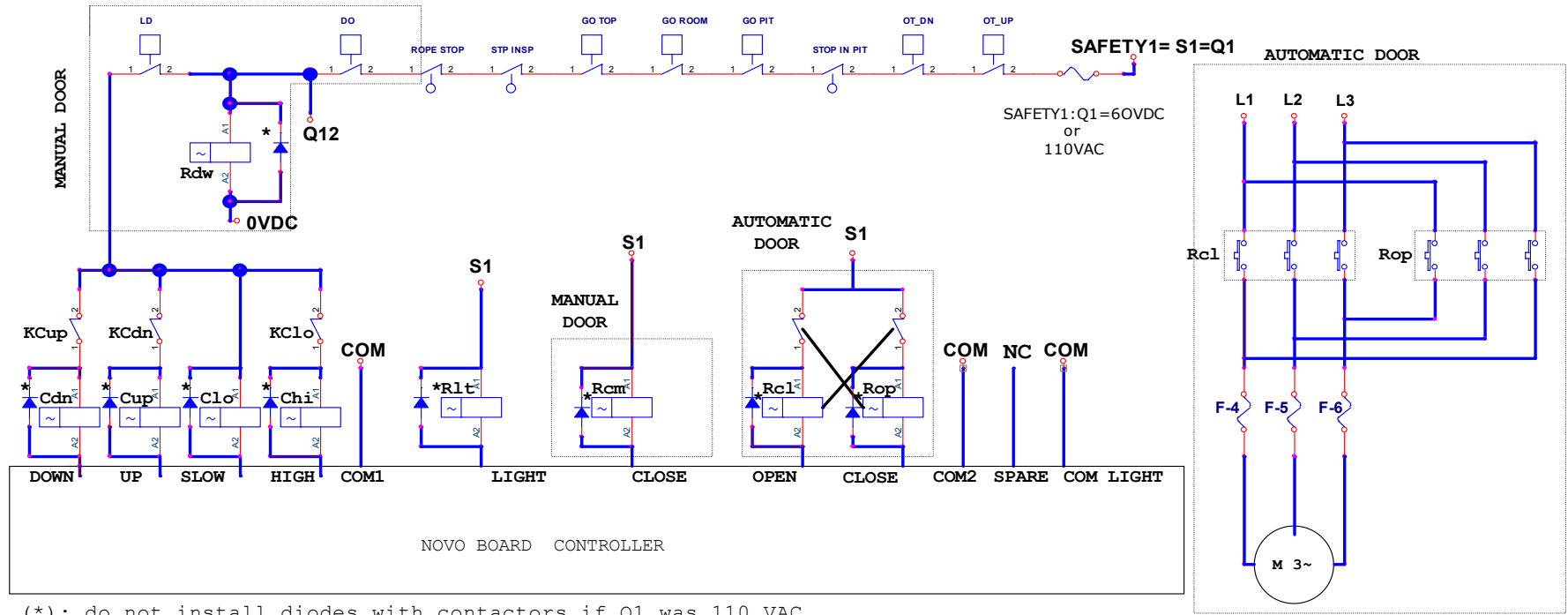

(*): do not install diodes with contactors if Q1 was 110 VAC

LD :	Lock door contact	Cdn:	Down direction contactor
DO :	Door contact mechanical switch	Cup:	Up direction contactor
STP INSP:	Stop inspection top of cabine	CLo:	Slow speed relay
GO TOP:	Overspeed governor top of cabine	Chi:	High speed relay
GO ROOM:	Overspeed governor machine room	Rlt:	Light relay
GO PIT:	Overspeed governor pit	Rcm:	Cam relay for swinging door
OT-DN:	Over travel down mechanical limit switch	Rcl:	Close door relay
OT-UP:	Over travel up mechanical limit switch	Rop:	Open door relay
Rdw:	Door contact relay	COM1:	Common for relay (Down,up, slow, high and spare) is connected to 0VAC or 0VDC
KCup:	Auxiliary switch for up direction contactor,should be N.C	COM2:	Common for relay: (open & close)is connected to 0AC or 0VDC depending on the chosen (110VAC or 60VDC)
KCdn:	Auxiliary switch for down direction contactor,should be N.C	COM LIGHT :	Common for relay car light is connected to 0AC or 0DC
KClO:	Auxiliary switch for low speed contactor,should be N.C	F-4, F-5, F-6:	Fuses

SMARTEC Technologies 55Hamdan bldg., Suite UG., Milano Rd. Beirut - Lebanon Telefax: + 961 1 278 956 www.smartechnologies.com	page description:	project:	date:
	AUTOMATIC /MANUAL DOOR AC2	NOVO BOARD CONTROLLER	February 14, 2014
			page:

TYPE OF DOOR

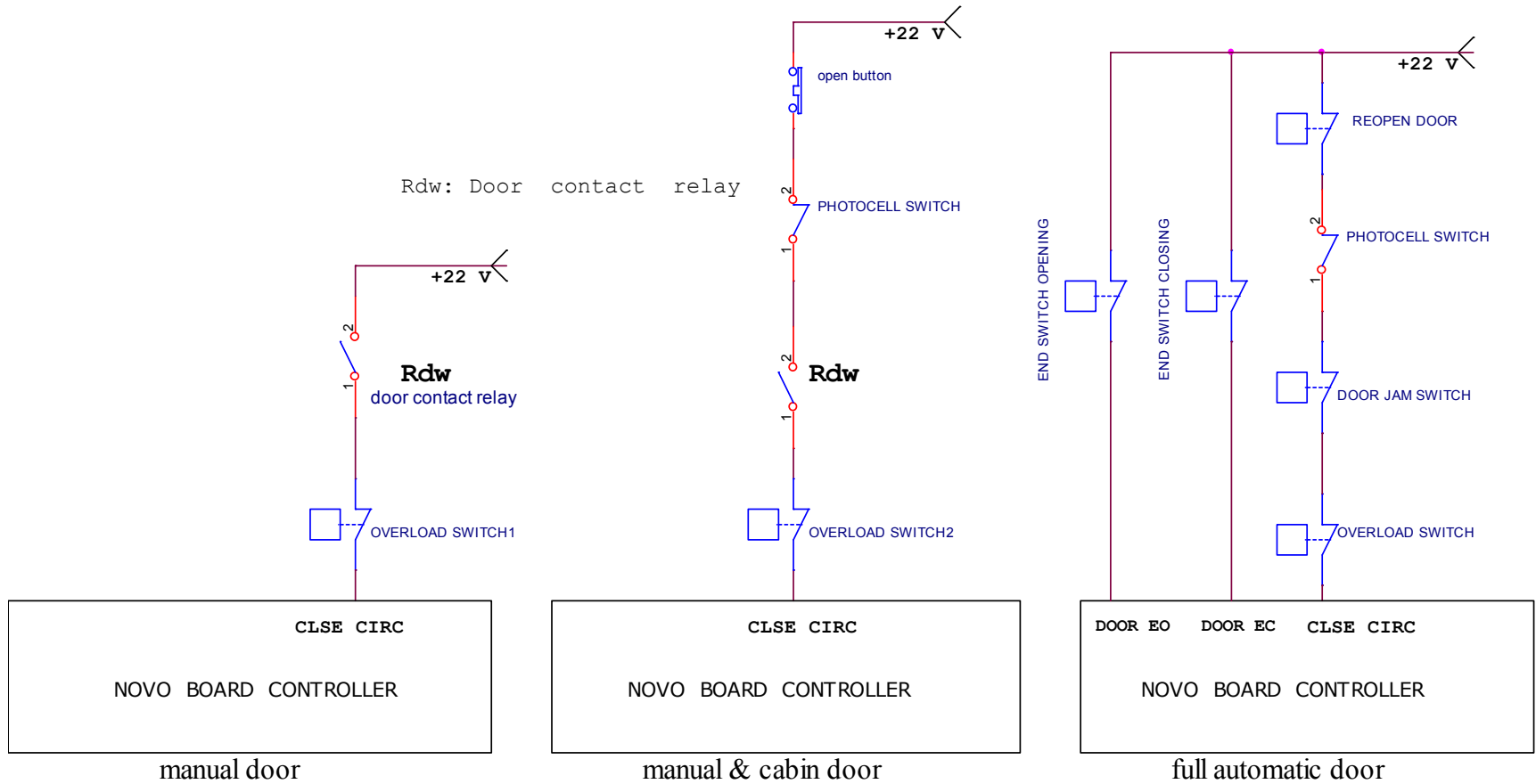

SMARTEC Technologies
 55Hamdan bldg., Suite UG., Milano Rd.
 Beirut - Lebanon
 Telefax: + 961 1 278 956
 www.smartectechnologies.com

page description:
 TYPE OF DOOR

project:
 NOVO BOARD CONTROLLER

date:
 February 14, 2014

page:

MAGNETIC SENSORS' DISPOSITION
For Bistable floor count

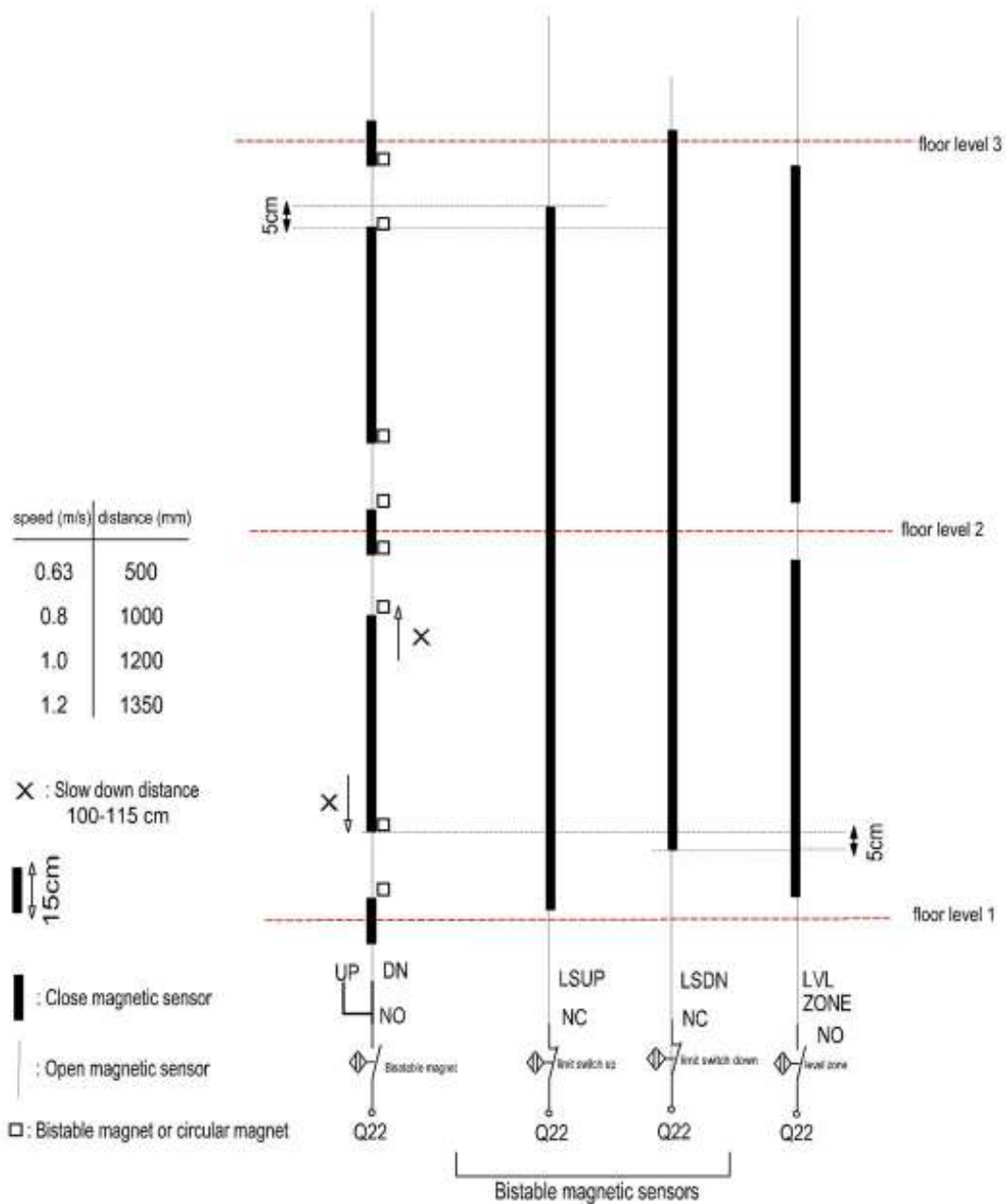

MAGNETIC SENSORS' DISPOSITION

For Monostable floor count

