

SPORTLINE[®]



HYDRACOACH[®]
INTELLIGENT WATER BOTTLE

USER GUIDE

PRINTED IN HONG KONG

TABLE OF CONTENTS

1. Introduction	3
2. Hydration Education and Information	4
3. The Heartbeat Behind HydraCoach	7
4. HydraCoach Description of Parts	8
5. Disassembling and Reassembling the HydraCoach	9
6. Battery Information and Installation	11
7. HydraCoach Button/Display Description	12
8. HydraCoach Initial Setup Mode	15
9. HydraCoach Functions	17
10. HydraCoach Screen Display Sequence	18
11. HydraCoach Operation	19
12. HydraCoach Reset	20
13. HydraCoach NOM Setup Modes	22
14. Helpful Tips	23
15. Warnings and Cautions	24
16. Proper Care and Cleaning	25
17. Troubleshooting	26
18. HydraCoach Disclaimer	27
19. Warranty and Service	27

**For an online version of the HydraCoach User Guide go to:
www.sportline.com**

SPORTLINE[®]

Sportline is a wholly owned subsidiary of E&B Giftware, LLC
© 2007 E&B Giftware LLC
Corporate Headquarters • 4 Executive Plaza • Yonkers, NY 10701
Tel: (914) 964-5200 • Fax: (914) 964-1283 • Toll Free 1-800-338-6337
U.S. Patent No. 6,212,959
SP3906ISOISPORA



Congratulations! As a new owner of the HydraCoach, you recognize the importance of proper daily hydration to a healthy, active lifestyle. The HydraCoach is the world's first interactive water bottle. It calculates your personal hydration needs, tracks your real-time fluid consumption, paces you throughout the day and motivates you to achieve and maintain optimal hydration. Doctors, Nutritionists and Fitness Trainers all recommend that we drink more water yet there has never been a device to help individuals adhere to the expert's recommendations. The HydraCoach is the only product of its kind and an evolutionary leap in personal hydration monitoring.

HYDRACOACH

who should use the HydraCoach?

Well, just about everyone. Proper hydration is critical to the health and well-being of all people regardless of age, sex or fitness level. This is particularly true for athletes and active individuals, anyone trying to lose weight, aging adults and children. However, most find it difficult to simply remember to drink fluids on a regular basis, let alone calculate and track their daily intake. The HydraCoach will provide immediate benefits by monitoring your personal consumption rate and motivating you to drink steadily through the day. Serious athletes to everyday health conscious individuals can now interactively manage their own fluid consumption to maximize the benefits of hydration while proactively preventing the ill-effects of both dehydration and over-hydration (Hyponatremia).



what are the benefits of proper hydration?



Water is the most fundamental nutrient to the human body. We can survive weeks without food but only days without water. Nearly every bodily function and cellular action requires water. At birth we are roughly 75% water but less than 50% water by adulthood. Proper hydration has been linked to everything from increasing metabolism to reducing the risks of some types of cancer. The health benefits of water are too great to list but include the following:

- **Transports nutrients and oxygen to cells**
- **Ensures adequate blood volume**
- **Protects against heat exhaustion**
- **Acts as insulation in the cold**
- **Regulates body temperature**
- **Cushions joints**
- **Suppresses appetite**
- **Assists the body in metabolizing stored fat**
- **Relieves fluid retention problems**
- **Reduces sodium buildup in the body**
- **Helps to maintain proper muscle tone**
- **Rids the body of waste and toxins**
- **Helps convert food into energy**
- **Maintains strength and endurance**
- **Protects organs**

how much water do we need on a **daily basis?**

Proper hydration is personal and determined by many factors such as gender, age, weight, environmental conditions and activity level. To ensure you are consuming the correct amount of fluids, our best advice is to consult your doctor.

The HydraCoach prompts you to enter your weight into the patented Hydration Monitor. With this information it automatically sets your Personal Hydration Goal (PHG) which is calculated as half your body weight (lbs.) displayed as ounces. For example, if you weigh 140 lbs., your PHG would be 70 ounces. This consumption goal is simply a baseline and may not reflect what's right for you. Toggle the PHG calculation up or down to reach your desired hydration goal.

what the experts **say about daily water consumption.**

The National Research Council (NRC) uses a sliding scale of 1 milliliter of water for every calorie burned. The NRC says the average man who burns about 2,900 calories daily needs 2,900 milliliters, or about 12 cups, of water each day. The average woman who burns 2,200 calories daily needs about 2,200 milliliters, or about 9 cups, of water each day¹. For your own calculations: One measuring cup (8 ounces) of water equals 236 milliliters of water.

¹Mayo Clinic, Consumer Health Tips and Products, June 25, 2002

the Heartbeat behind **HydraCoach:**

The Craig and Kelly Perkins story



HydraCoach was founded by world-renowned climbers, Craig and Kelly Perkins, who conceived the idea out of personal necessity.

In September, 1996, Craig and Kelly were making their way down Half Dome in Yosemite after reaching its summit. This was Kelly's first serious hike following a heart transplant operation only ten months earlier. Using a concealed hydration backpack, Kelly was unable to gauge her rate of fluid intake during the climb. Disastrously, she ran out of water four miles from the nearest stream. Severe dehydration put Kelly back in the hospital where she fortunately made a full recovery.

Knowing proper hydration is critical to fitness and health, Craig and Kelly set out to devise a tool to help individuals quantify, achieve and maintain optimal hydration. The HydraCoach is the result of their experience and vision, and an evolutionary leap in hydration monitoring. As a tribute to Kelly and other organ transplant recipients, a portion of the proceeds generated from this product will be used to support organ donation.

Disassembling and Reassembling the HydraCoach

HYDRACOACH DESCRIPTION OF PARTS

Please read instructions thoroughly before using the HydraCoach.

1. Mouthpiece
2. Upper Cap with Finger Ring
3. Impeller Assembly
4. Tubing
5. Bezel
6. Computer
7. Bottle

IMPELLER ASSEMBLY

Short Connector Tube



Impeller Housing



Draw Tube

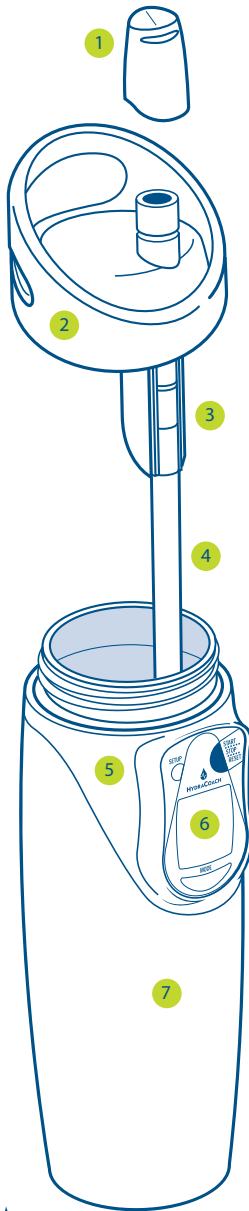

The HydraCoach can be easily disassembled, and reassembled, to change the battery, refill the bottle, replace a part, or to clean. There are seven main components to the HydraCoach. The exploded view illustration shows where each of these parts locate in relation to one another, and explains how they all fit together. To ensure that the system works properly, it is important that these components join to one another properly.

UPPER CAP ASSEMBLY AND BOTTLE

To remove the Upper Cap from the Bottle, simply twist the outer threaded Finger Ring in a counter-clockwise direction. When the Finger Ring has been unscrewed completely, you will be able to lift the Upper Cap, along with the attached Impeller/Tube Assembly, up and off of the Bottle.

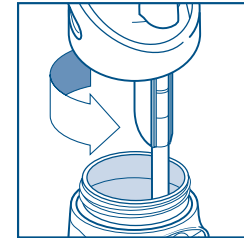

To replace the Upper Cap, position the Mouthpiece at the front of the Bottle. The tabs on the Plug will automatically align with the slots in the Bottle. Gently press the cap downward to ensure that the tabs engage the slots, and then twist the Finger Ring in a clockwise direction until the Upper Cap is fully screwed down onto the Bottle for a snug and watertight fit.

UPPER CAP AND IMPELLER ASSEMBLY WITH TUBING

To remove the Impeller Assembly with Tubing, simply grasp the hard plastic housing of the Impeller Assembly and pull it down and away from the Upper Cap. The tabs in the rail of the Impeller Assembly will disengage from the notches on the rails of the Upper Cap.

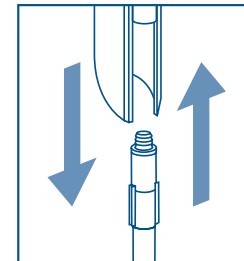

At the same time, the Impeller Assembly will also disengage from the short Connector Tube and the Upper Cap.

To replace the Impeller Assembly with Tubing, simply reverse this process. Make sure that both of the rails are aligned properly so that the Impeller Assembly's locking tabs engage the notches in the Upper Cap. Gently push the Impeller Assembly up and into the short Connector Tube and the Upper Cap making sure that the barbed fitting is securely inserted within. At this point, you should hear an audible "click" indicating that the Impeller Assembly with Tubing is properly attached to the Upper Cap.

IMPELLER ASSEMBLY AND TUBING

Both the Short Connector Tube and the Longer Draw Tube that attach to either end of the Impeller Housing may be removed and then reattached by simply pulling them off and pushing them back on to the barbed fittings.

Note: The Impeller Housing and Tubes can only fit together in one orientation or the system will not work. Please make sure that the Short Connector Tube is at the top of the Impeller Housing (defined by the check valve inside) and the Longer Draw Tube is at the bottom.



MOUTHPIECE AND UPPER CAP ASSEMBLY

To remove the Mouthpiece, grasp it firmly and pull until it comes free of the Upper Cap.

To replace the Mouthpiece, simply press it over and down on to the stem of the Upper Cap until it is properly seated.

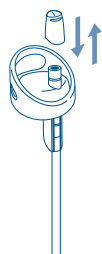

BEZEL WITH COMPUTER AND PC BOTTLE

With the Upper Cap removed from the Bottle, the Bezel with attached Computer may be lifted up and off the Bottle as a single piece. To replace, simply reverse the process and press the Bezel with Computer back down and onto the Bottle.

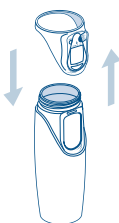

COMPUTER AND BEZEL

The Computer detaches from the Bezel by means of a tab and notch system. Simply pinch both sides of the Bezel inward while gently pressing on the Computer's face, and the Computer will come free from the Bezel. Note: The Computer only fits within the Bezel from the rear and in one orientation. To replace the Computer, simply place it into the back of the Bezel and press until you feel the locking tabs of the Bezel engage the notches in the Computer.

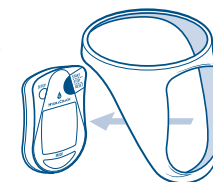

Battery

Information and Installation

The HydraCoach computer comes with an installed CR2032 3 Volt Lithium battery. To ensure the battery retains its maximum charge, an insulation tab has been inserted. In order to activate the computer, this insulation tab must be manually removed and the battery reinstalled. To remove insulation tab, please follow steps on following page.

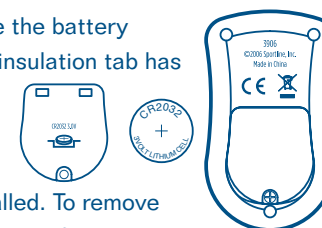

IMPORTANT NOTE

- This product uses non-rechargeable batteries
- Do Not use old batteries
- Exhausted batteries need to be removed - the display will be very weak when batteries need replacing
- Do Not dispose of battery in fire; battery may explode or leak
- Do Not dispose of product in fire; battery may explode or leak

Under normal circumstances the battery should last approximately 6 months. When it is time to replace the battery, a Low Battery Icon  will appear in the upper right hand corner of the display and flash. Note: Always recycle or dispose of dead batteries properly, and in accordance with your local laws.



PROCEDURE FOR REMOVING AND REINSTALLING THE BATTERY IS AS FOLLOWS:

STEP 1: Remove the screw from the battery door on the back of the computer using an appropriate screwdriver. Note: The screw will come free when unfastened, so be careful not to lose it during this process.

STEP 2: Using a fingernail within either of the two pry slots, gently lift the battery door open and remove the battery from the battery compartment.

STEP 3: To reinstall the battery, simply place it down into the battery compartment with the positive (+) side facing out. Note: Be careful not to touch or bend any of the battery contacts within the battery compartment during installation.

STEP 4: Replace the battery door making sure that the o-ring seal does not get pinched or distorted, and refasten the screw to ensure that the computer is water-resistant. Note: The screw should be snug. However, to avoid damage to the battery door and fastener system, do not over-tighten the screw.

After installing a new battery, you will need to re-program the HydraCoach. Please follow initial set-up mode instructions on page 15.

MAIN DISPLAY

- A** Function Abbreviations (TAC, TET, PHG, %DG, CLK, DAY)
- B** Upper Line Display
- C** Lower Line Display
- D** Tertiary Line Display
- E** Tertiary Line Function/Unit Abbreviations (AVG, L/HR, OZ/HR)
- F** Upper/Lower Line Unit Abbreviations (PM, KG, LB, L, OZ)

ABBREVIATION AND ICON DEFINITIONS

- TAC** Total Amount Consumed
- TET** Total Elapsed Time
- PHG** Personal Hydration Goal
- %DG** Percent of Daily Goal
- CLK** Clock
- DAY** Date
- AVG** Average Consumption
- L/HR** Liters Per Hour
- OZ/HR** Ounces Per Hour
- PM** PM Time Designation
- LB** Pounds
- KG** Kilograms
- L** Liters
- OZ** Ounces

Low Battery Icon 

Stop Watch Icon 

HydraCoach
Button/Display Description

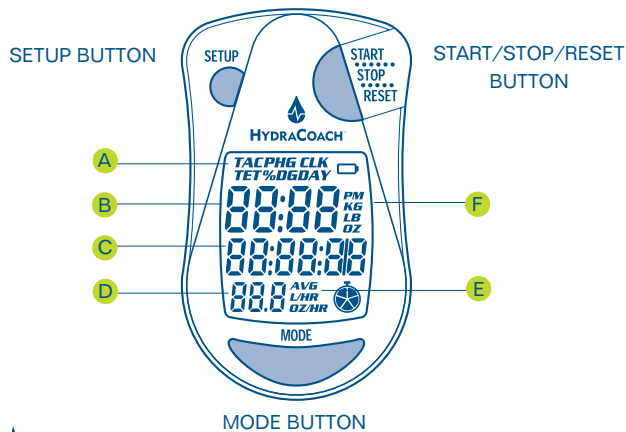

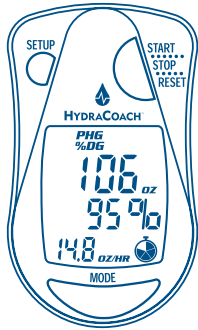

HYDRACOACH®

The Intelligent Water Bottle



Personal Hydration Calculator
Automatically calculates a recommended daily Personal Hydration Goal.



Average Consumption
Displays the average amount of fluid consumed per hour.



Drink Monitor
Monitors the total amount of fluid consumed throughout the day.



Sip Tracker
Displays the percentage of fluid consumed relative to your Personal Hydration Goal.



Time Tracker
Displays the amount of time elapsed for the day to reinforce proper pacing.

HydraCoach Initial Setup Mode

After battery installation, the computer displays the program's master screen briefly, and then automatically enters into the Initial Setup Mode. This Initial Setup Mode may be accessed in two ways: 1) After a battery insertion (the program will display factory default settings), or 2) When both the Setup and Start/Stop/Reset buttons are pressed and held simultaneously for 2 seconds (the program will display user preset settings).

The Initial Setup Mode allows you to select operational units and enter personal data in order to customize the HydraCoach Hydration Program to meet your needs. All steps in the Initial Setup Mode have been preprogrammed. If an entry error is made, complete the Initial Setup Mode program and then re-enter from the Normal Operating Mode as described above to revise the setting(s).

SETUP MODE BUTTON OPERATIONS

Mode Button – Toggles through units and advances digits. Hold down for fast advance.

Setup Button – Sets units or digits and advances to the next item or screen.

Start/Stop/Reset Button – Has no function in Setup Mode.

INITIAL SETUP MODE PROGRAM

Units of Fluid Measure

Select OZ (Ounces) or L (Liters) as the program's default unit of fluid measure. Note: The default setting for Units of Fluid Measure is Ounces (OZ).



Units of Weight

Select LB (Pounds) or KG (Kilograms) as the program's default unit of weight. Note: The default setting for Units of Weight is Pounds (LB).



Current Weight

Enter your current weight into the computer one digit at a time.

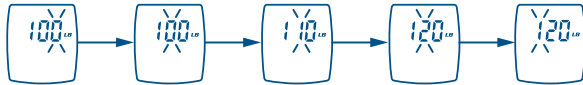

Personal Hydration Goal (PHG)

Based on your previously programmed weight, the computer will automatically calculate your recommended daily Personal Hydration Goal (PHG) value and display it on the screen. This value may be accepted or adjusted up or down to meet your personal daily fluid requirements.



Clock Format

Select 12 or 24 Hour clock format. Note: The default setting for Clock Format is 12 Hour.

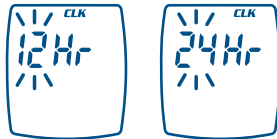

Current Time

Enter the current time into the computer in hours and minutes. Note: There is only a PM time designation in 12 Hour format; there is no AM time designation.

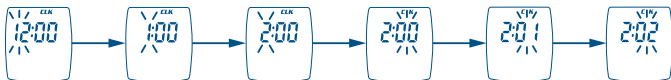

Current Date

Enter the current month, day and year into the computer.



HydraCoach Functions

TOTAL AMOUNT CONSUMED (TAC)

This function displays the total amount of fluid that has been consumed since the HydraCoach was started. Value resolution for Ounces is in whole numbers, and in Liters to tenths.



TOTAL ELAPSED TIME (TET)

This function is a count-up timer that displays the total elapsed time since the HydraCoach was started.



AVERAGE CONSUMPTION (AVG)

This function displays the average hourly rate of fluid consumption. Data displays after one minute of total elapsed time. Note: Values that are out of the program's operating range will display as dashes on the screen. Real-time values will replace these dashes as soon as they fall within the program's operating range.



PERSONAL HYDRATION GOAL (PHG)

This function displays your Personal Hydration Goal for the day. The PHG value is defined as the amount of fluid that an individual should consume over the course of a 24-hour day to maintain optimal hydration. Based on your current weight, this value is automatically generated by the HydraCoach program in the Setup Mode. The PHG value should be adjusted up or down to meet your specific needs.



PERCENT OF DAILY GOAL (%DG)

This function displays, in real-time, the total amount of fluid consumed, expressed as a percentage of your daily PHG.



CLOCK (CLK)

This function displays, in 12 or 24-Hour format, the current time.



DATE (DAY)

This function displays, in Month/Day/Year format, the current calendar date.



HydraCoach Screen Display Sequence

When you have completed the Initial Setup Mode, the computer will automatically enter into the Normal Operating Mode (NOM). There are three NOM function screens. The first two are specific to the Hydration Program, while the third displays the time and date.

Normal Operating Mode (NOM) Function Screens

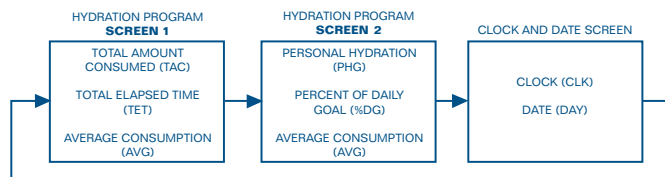

Press the Mode button to cycle through the NORMAL OPERATING MODE (NOM) function screens.

HydraCoach Operation

Starting and Stopping the Hydration Program

All Hydration Program operations are executed by means of the Start/Stop/Reset button and may only be performed from within either of the two Hydration Program screens (TAC/TET/AVG or PHG/%DG/AVG). Note: The Hydration Program may never be started or stopped, or a NOM reset performed, from the Clock and Date screen (CLK/DAY).

To start the HydraCoach, make sure that you are in either the TAC/TET/AVG or PHG/%DG/AVG screen, and press the Start/Stop/Reset button. A Stopwatch icon will begin running in the lower right hand corner of the display. This indicates that the Hydration Program is active, and that you may begin drinking at any time.

To stop the HydraCoach, make sure that you are in either the TAC/TET/AVG or PHG/%DG/AVG screen, and press the Start/Stop/Reset button. The Stopwatch icon will pause, and all Hydration Program functions will cease updating. The HydraCoach will display the information that was last recorded before the computer was stopped. To resume the Hydration Program, press the Start/Stop/Reset button again in either the TAC/TET/AVG or PHG/%DG/AVG screen, and all functions will pick up where they last left off.

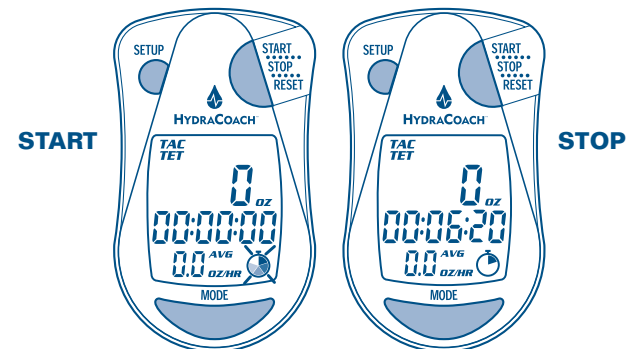

HydraCoach Reset

Press the Mode Button to cycle through the NORMAL OPERATING MODE function screens.

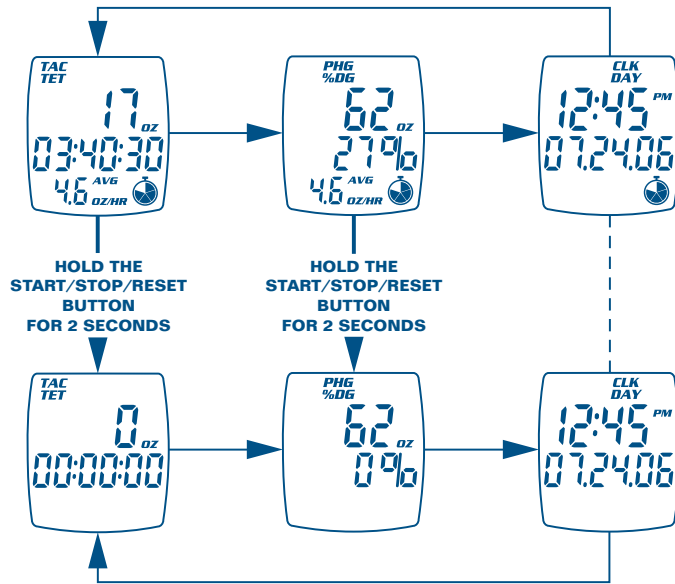

NOM RESET

The HydraCoach may be reset at any time. To do this, the HydraCoach must first be stopped as described in the previous section. From either the TAC/TET/AVG or PHG/%DG/AVG screen, press and hold the Start/Stop/Reset button for 2 seconds. All Hydration Program functions will reset to zero or their last set default values. The computer is now ready to start a new Hydration Program.

24-HOUR LIMIT RESET

The HydraCoach monitors the amount of fluid that an individual consumes over the course of a 24-hour day. When the Total Elapsed Time (TET) function reaches 24 hours, the HydraCoach

will stop automatically. All NOM function screens will begin flashing to notify you that the 24-hour time limit has been reached. At this point, you may either toggle through the NOM function screens to review your end-of-day data by means of the Mode button, or you may reset the computer and begin a new Hydration Program.

To reset the Hydration Program after the 24-hour time limit has been reached, simply press and hold the Start/Stop/Reset button for 2 seconds in any of the flashing NOM function screens. Note: This is the only case in which the Hydration Program may be reset from the Clock and Date screen (CLK/DAY). All Hydration Program functions will reset to zero or their last set default values. The computer is now ready to start a new Hydration Program.

Press the Mode Button to cycle through the NORMAL OPERATING MODE function screens.

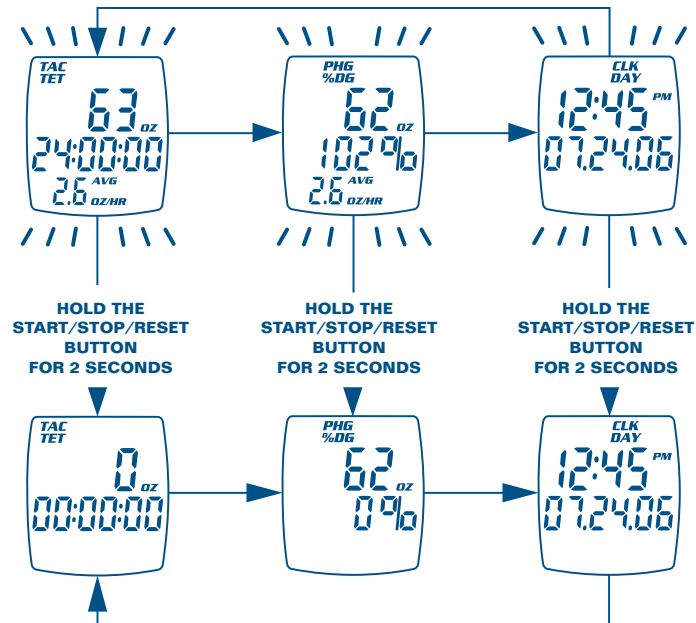

HydraCoach

NOM Setup Modes

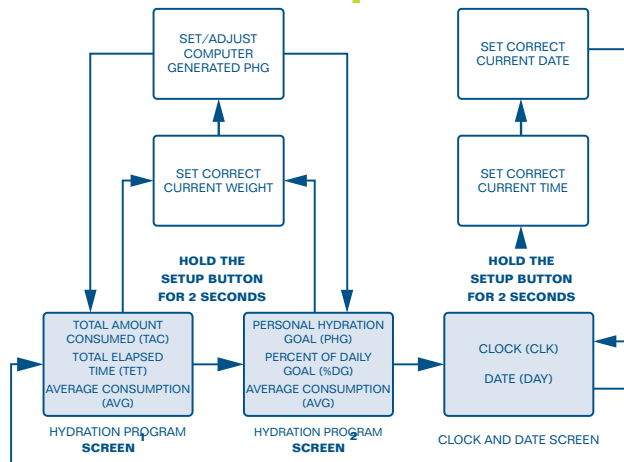

Press the Mode Button to cycle through the NORMAL OPERATING MODE function screens.

There are two NOM Setup Modes. Each may be accessed directly from within specific NOM function screens whether the Hydration Program is active or not. These NOM Setup Modes enable quick and convenient program setting changes without having to stop the HydraCoach. Changes made while in the NOM Setup Modes will be realized immediately once you return back to the Normal Operating Mode. To enter into either of the NOM Setup Modes, press and hold the Setup button for 2 seconds while in the appropriate NOM function screen.

WEIGHT AND PHG SETUP

The first NOM Setup Mode allows you to adjust your weight and manipulate your PHG value, and is accessed via the TAC/TET/AVG or PHG/%DG/AVG function screens. Note: The NOM Setup Mode button operations are the same as in the Initial Setup Mode.

CLOCK AND DATE SETUP

The second NOM Setup Mode allows you to adjust the time and date, and is accessed via the CLK/DAY function screen.

Helpful Tips

Some useful information and insights to help you make the most of your HydraCoach experience...

- Drinking from the HydraCoach using the Mouthpiece is a two-step process. With your lips around the mouthpiece, locate your teeth on the indents at the tip and bite down to open the slit. **To ensure accuracy take a good suck in, just like you would with a straw, to draw the fluid from the bottle up in to your mouth.** When finished, simply remove your mouth from the Mouthpiece and the slit will automatically seal itself to protect against accidental spillage.
- The PHG value may be adjusted throughout the day to accommodate your personal hydration needs. The PHG value may be adjusted up to address greater fluid needs as a result of exercise, the environment, illness or health conditions, pregnancy or other variables. The PHG value may also be adjusted down to account for fluids consumed from alternate sources other than the HydraCoach. Before embarking on a custom hydration program, please consult your doctor on all issues related to your personal hydration requirements.
- The Bottle should be refilled when the water line reaches the ----REFILL---- mark on the lower back portion of the bottle. This ensures that no air is sucked through the system resulting in erroneous readings. The accuracy of the HydraCoach relies on maintaining a "closed system" in which water is captured within the Impeller Assembly and Tubing at all times.
- Do not tip the bottle too far forward while you drink. Think of it more like drinking from a straw in a cup. Keep the bottle oriented in a vertical position for it to work most effectively. The bottle may be slightly tipped forward while drinking for ease of use. Do not tip it upside down to drink as you would with open lid or squirt style bottles.

- It is perfectly all right to put ice in the bottle to keep your drink cold.
- When adding water to the bottle, **DO NOT** fill to the very top. When the Upper Cap is screwed down, water will be displaced and spill out.
- When transporting a filled HydraCoach, especially within a bag or other confined space, make sure that the Mouthpiece does not become compressed or deformed in any way, or water will be released from the system.

Warnings and Cautions

Important things to be aware of when using your HydraCoach...

- **DO NOT** place boiling or very hot liquid into the HydraCoach bottle as it could potentially damage or compromise some of the seals and/or components located within the system.
- The use of fluids other than water within the HydraCoach could potentially damage or compromise some of the seals and/or components located within the system, especially if left to sit and dry.
- **DO NOT** allow air to be sucked up into the system, as this will produce erroneous readings.
- The Computer is water-resistant and sealed to withstand wet conditions. However, **DO NOT** deliberately place or submerge the HydraCoach into water.
- Avoid leaving the HydraCoach exposed to extremely hot or cold conditions.
- **WARNING:** The HydraCoach is **NOT** microwave safe.
- Although designed and manufactured for durability and performance, the HydraCoach contains sensitive electronic and magnetic components. Care should be taken when handling to minimize any risks, due to extreme impacts or shock, which might damage the unit.

Proper Care and Cleaning

The HydraCoach disassembles into seven main components. (See Disassembling and Reassembling the HydraCoach) This allows you to clean the system easily and thoroughly. The best methods for cleaning the individual components are as follows:

Bottle – The Bottle may be placed in a dishwasher or washed by hand in warm soapy water. It may then be wiped dry with a soft cloth or left to air dry. **DO NOT** place the electronic module in the dishwasher.

Computer – The Computer may be polished with a soft cloth in most cases. However, a slightly damp cloth may be used if necessary. Note: Be careful not to scratch the lens area. Never use solvents, abrasives, or harsh chemicals or materials to clean the Computer. Never submerge the Computer in water or other liquid medium. **DO NOT** place in the dishwasher.

Impeller Assembly and Tubing – To thoroughly clean the Impeller Assembly and Tubing, they should first be soaked in warm soapy water, making sure that no air is trapped within the components. Next, flush the system with a stream of warm running water through the bottom end, or the end that the longer Draw Tube attaches. Once flushed thoroughly, it is now ready for use. To dry, the Tubing should be disconnected from the Impeller Assembly, air blown through the components to rid the system of excess water, and then left to air dry.

Mouthpiece, Upper Cap and Bezel – These components are best washed by hand in warm soapy water and then rinsed clean. However, they may be placed in a dishwasher's upper rack and away from heating elements if absolutely necessary. They may then be wiped dry with a soft cloth or left to air dry.

When not in use, the HydraCoach should be allowed to dry completely and then stored away for safe keeping until you want to use it again.

Troubleshooting

The HydraCoach seems to be reading low.

You may be sucking too lightly. Try sucking a little harder through the Mouthpiece. (See the Helpful Tips section in this manual for more details)

The HydraCoach seems to be reading high.

Make sure that you are not sucking any air through the system. Ensure that there is always water contained within the Impeller Assembly and Tubing while in use. (See the Helpful Tips section in this manual for more details)

The Computer does not register my fluid intake after I drink from the HydraCoach.

The Hydration Program has not been started, or is paused. (See the HydraCoach Operation section in this manual for more details)

The HydraCoach is assembled improperly. (See the Disassembling and Reassembling the HydraCoach section in this manual for more details)
The Impeller may be bound or seized. Check to make sure that the Impeller spins freely within its housing.

The Computer behaves erratically, experiences "lock-ups" or the display is weak or fades in and out.

The Battery may be weak and/or dying. Check to see if the Low Battery Icon is flashing on the display to indicate replacement. (See the Battery Information and Installation section in this manual for more details)

The Computer's LCD and other sensitive components do not operate well in extremely hot or cold conditions. Return the HydraCoach to a less extreme environment.

Check the components for cracks or breaks, and the fit of all assemblies to ensure that the system is air and water tight. A system that is compromised by air or water leaks will cause the HydraCoach to malfunction. Tighten any loose fittings.

The Computer's display is blank or does not light up.

The Battery is completely dead, not installed or the factory installed Insulation Tab may still be inside the battery compartment. (See the Battery Information and Installation section in this manual for more details)

It is difficult to suck water through the tubing and mouthpiece.

The Mouthpiece and/or Air Check Valve may not be fully cut through. Try pinching and rolling the Mouthpiece between your thumb and index finger to open the slit completely. Run a fingernail across the Air Check Valve to separate the four triangular shaped flaps from one another to allow air to more easily pass through.

HydraCoach Disclaimer

The HydraCoach is not a medical tool and should not be used as one. The Personal Hydration Goal calculation offers only a general guideline for daily fluid consumption and may not be an appropriate recommendation for many. Neither HydraCoach nor Sportline make any medical claims or instruction with respect to individual hydration requirements. Please consult your doctor on all issues related to your own hydration requirements.

Warranty and Service

For purchases made in the U.S. If at any time within one (1) year from the purchase date of this product, it fails to perform properly because of defects in material or manufacturing, return it prepaid to:

E&B GIFTWARE, LLC, 585 Oak Ridge Road, Hazleton, PA 18202

Complete this Guarantee Certificate and enclose it (or a copy of it) with the product. **(PLEASE PRINT CLEARLY)**

NAME	TEL
ADDRESS	CITY
STATE	ZIP
STORE PURCHASED FROM	
DATE OF PURCHASE	PURCHASE PRICE
PROBLEM WITH PRODUCT	

REPLACEMENT

This product has been carefully designed, manufactured and packaged. If any parts are missing or damaged, please contact us at the address above and we will replace the unit at no charge. (Guarantee does not cover crystal or battery.)

For purchases made in the UK:

Should you experience problems with this item, please return it to the point of purchase. This will not affect your statutory rights. Alternatively return it to the address shown below for a repair/replacement.

StarCase (UK) Ltd, Berkeley Business Park, Wainwright Road,
Worcester WR4 9FA.

www.hydracoach.com

www.sportline.com