

USER'S MANUAL

⚠ READ BEFORE USE! **Factory No.: HYPH50061-6** **Style No.: 65211**

Propane Patio Heater



⚠ IMPORTANT

Read this manual carefully before assembling, using or servicing this heater. Keep this manual for future reference.

⚠ FOR YOUR SAFETY

If you smell gas:

1. Shut off gas to the appliance.
2. Extinguish open flame.
3. If odor continues, keep away from the appliance and immediately call your gas supplier or the fire department.



**COMPLIES WITH ANSI Z83.26a-2008/CSA 2.37a-2008 STANDARDS
FOR GAS-FIRED OUTDOOR INFRARED PATIO HEATERS**

Contents

General Safety Information.....	2
Assembly Instructions	
Components.....	4
Components List.....	5
Installation Process	
Step 1 - Attach Post Assembly to Cylinder Housing...5	
Step 2 –Attach Head Assembly to Post.....6	
Step 3 –Attach Reflector Stud to Head Assembly.... 6	
Step 4 –Attach Center Reflector to Reflector Panel...7	
Step 5 –Attach Reflector Assembly to the top of Head Assembly.....	8
Connect Hose & Regulator to Cylinder.....	8
Check for leaks.....	9
Minimum clearances.....	10
Operation.....	10
Storage	12
Maintenance.....	12
Service.....	14

General Safety Information

This manual contains important information about the assembly, operation and maintenance of this patio heater. General safety information is presented in these first few pages and is also located throughout the manual.

Keep this manual for future reference and to educate new users of this product. This manual should be read in conjunction with the labeling on the product.

Safety precautions are essential when any mechanical or propane fueled equipment is involved. These precautions are necessary when using, storing, and servicing. Using this equipment with the respect and caution demanded will reduce the possibilities of personal injury or property damage.

The following symbols shown below are used extensively throughout this manual. Always heed these precautions, as they are essential when using any mechanical or **propane fueled equipment**.

DANGER

DANGER indicates an imminently hazardous situation which, if not avoided, will result in death or serious injury.

WARNING

WARNING indicates an imminently hazardous situation which, if not avoided, could result in death or serious injury.

CAUTION

CAUTION indicates an imminently hazardous situation which, if not avoided, may result in minor or moderate personal injury, or property damage.

WARNING

Do not store or use gasoline or other flammable vapor and liquids in the vicinity of this or any other appliance.

An LP-cylinder not connected for use shall not be stored in the vicinity of this or any other appliance.

WARNING: For Outdoor Use Only

WARNING

Improper installation, adjustment, alteration, service or maintenance can cause injury or property damage. Read the instructions thoroughly before installing or servicing this equipment.

DANGER

Failure to comply with the precautions and instructions provided with this heater can result in death, serious bodily injury and property loss or damage from hazards of fire, explosion, burn, asphyxiation, and/or carbon monoxide poisoning.

Only persons who can understand and follow the instructions should use or service this heater.

DANGER

• EXPLOSION - FIRE HAZARD

- Keep solid combustibles, such as building materials, paper or cardboard, a safe distance away from the heater as recommended by the instructions.
- Provide adequate clearances around air openings into the combustion chamber.
- Never use the heater in spaces which do or may contain volatile or airborne combustibles, or products such as gasoline, solvents, paint thinner, dust particles or unknown chemicals.
- During operation, this product can be a source of ignition. Keep heater area clear and free from combustible materials, gasoline, paint thinner, cleaning solvents and other flammable vapors and liquids. Do not use heater in areas with high dust content. Minimum heater clearances from combustible materials: three (3) feet from the sides & two (2) feet from the top.

WARNING

We cannot foresee every use which may be made of our heaters.

Check with your local fire safety authority if you have questions about heater use.

Other standards govern the use of fuel gases and heat producing products for specific uses. Your local authorities can advise you about these.

If no local codes exist, follow National Fuel Gas Code, ANSI Z223.1. In Canada, installation must conform to local codes. If no local codes exist, follow the current National standards of CANADA CAN/CGA-B 149.2.

DANGER

• CARBON MONOXIDE HAZARD

- This heater is a combustion appliance. All combustion appliances produce carbon monoxide (CO) during the combustion process. This product is designed to produce extremely minute, non-hazardous amounts of CO if used and maintained in accordance with all warnings and instructions. Do not block air flow into or out of the heater.
 - Carbon Monoxide (CO) poisoning produces flu-like symptoms, watery eyes, headaches, dizziness, fatigue and possibly death. You can't see it and you can't smell it. It's an invisible killer. If these symptoms are present during operation of this product get fresh air immediately!
 - For outdoor use only .
 - Never use inside house, or other unventilated or enclosed areas.
 - This heater consumes air (oxygen). Do not use in unventilated or enclosed areas to avoid endangering your life.

CAUTION

• SERVICE SAFETY

- Keep all connections and fittings clean. Make sure propane cylinder valve outlet is clean.
- Inspect hose before use. Replace if there is evidence of abrasion or wear.
- During set up, check all connections and fittings for leaks using soapy water. Never use a flame.
- Use as a heating appliance only. Never alter in any way or use with any device.
- Check entire hose at least annually.

WARNING

• BURN HAZARD

- Never leave heater unattended when hot or in use.
- Keep out of reach of children.

⚠ WARNING

- This product is fueled by propane gas. Propane gas is invisible, odorless, and flammable. An odorant is normally added to help detect leaks and can be described as a "rotten egg" smell. The odorant can fade over time so leaking gas is not always detectable by smell alone.
- Propane gas is heavier than air and leaking propane will sink to the lowest level possible. It can ignite by ignition sources including matches, lighters, sparks or open flames of any kind many feet away from the original leak. Use only propane gas set up for vapor with draw.
- Propane gas should be stored or used in compliance with local ordinances and codes or with ANSI/NFPA 58. Turn off propane when not in use.

⚠ DANGER

- **EXPLOSION - FIRE HAZARD**
- Never store propane near high heat, open flames, pilot lights, direct sunlight, other ignition sources or where temperatures exceed 120 degrees F (49°C).
- Propane is heavier than air and can accumulate in low places. If you smell gas, leave the area immediately.
- Never install or remove propane cylinder while heater is lighted, near flame, pilot lights, other ignition sources or while heater is hot to touch.
- This heater is red hot during use and can ignite flammables too close to the burner. Keep flammables at least 3 feet from sides & 2 feet from top. Keep gasoline and other flammable liquids and vapors well away from heater.
- The propane cylinder must always be stored outdoors in a well ventilated space. Never store propane cylinder in an enclosed area (house, garage, etc.). If heater is to be stored indoors, disconnect the propane cylinder for outdoor storage.

Assembly Instructions

Components

- Remove all components from package.

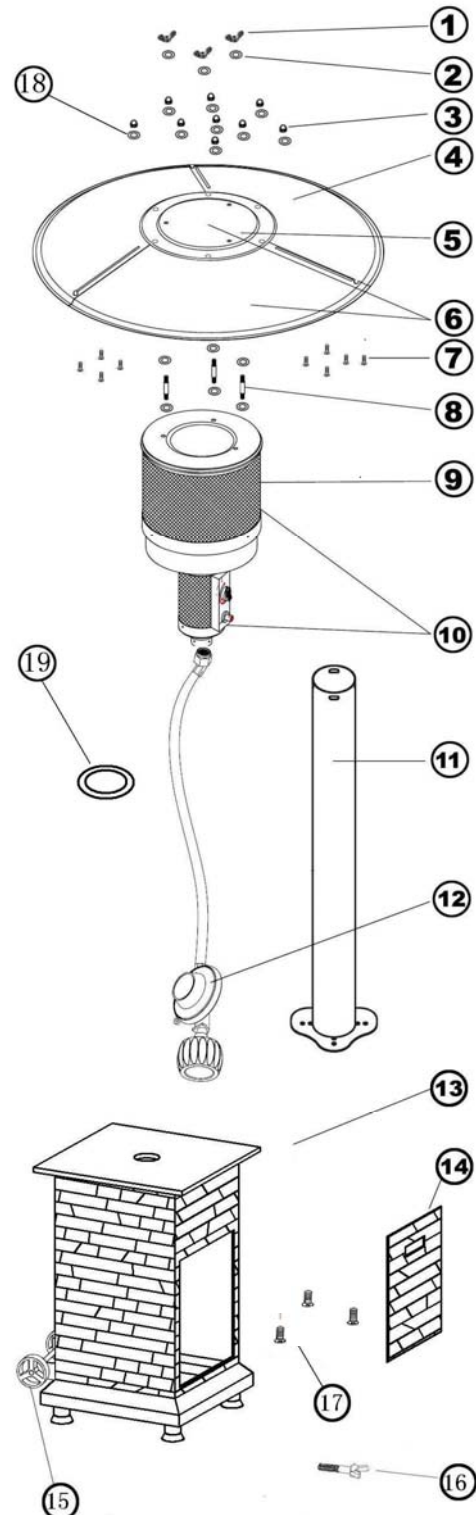

Components List

Part No.	Description	Qty	Part No.	Description	Qty
1	Wing Nut	3	2	Flat Washer	9
3	Cap Nut	9	4	Reflector Panel	3
5	Center Reflector	1	6	Reflector Assembly	1
7	Small Screw M6	9	8	Reflector Stud	3
9	Heater Burner Screen	1	10	Head Assembly	1
11	Post	1	12	Regulator	1
13	Cylinder Housing	1	14	Cylinder Housing Door	1
15	Wheel Assembly	1	16	Wing Screw	1
17	Screw M5 X 10	3	18	Small Flat Washer	9
19	Cup	1			

Installation process

Note: You must follow all steps to properly assemble heater.
Do NOT attempt to assemble without proper tools.

Step 1 – Attach Post Assembly to Cylinder Housing

■ Attach the post to the cylinder housing using M5x10 Screw (3pcs). Please see **Figure 1** and **Figure 2**

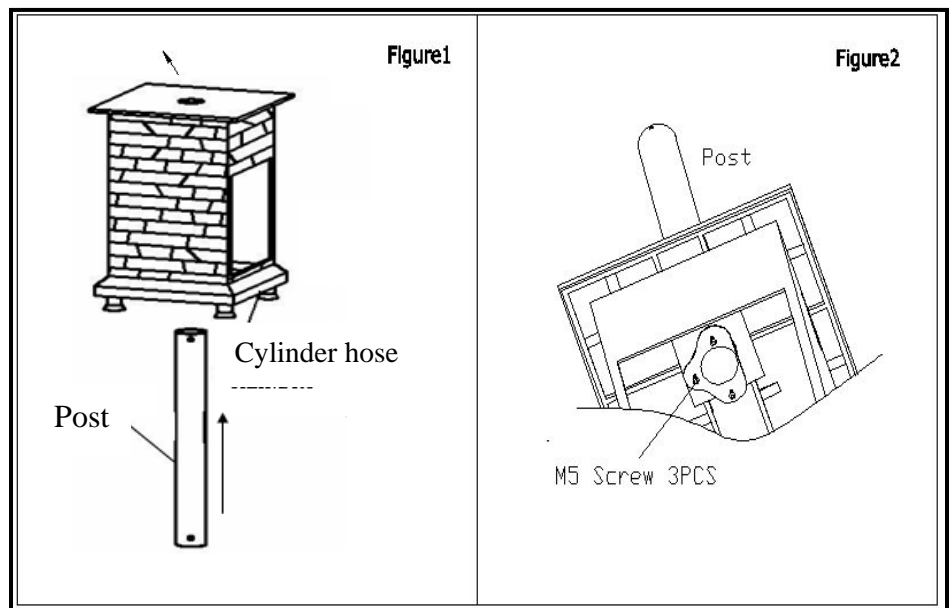

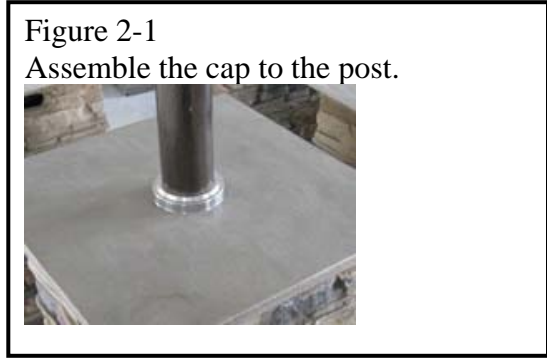
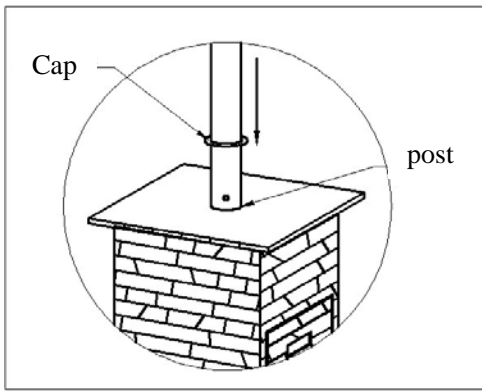

Step 2 –Attach Head Assembly to Post

- Screw off 4pcs bolts which preassembling on the head assembly. Please see **Figure 3**.
- Load head assembly by inserting gas hose into post. Please see **Figure 4 and Figure 5**
- Insert head assembly into post. Tighten securely using bolts (4pcs). Please see **Figure 6**

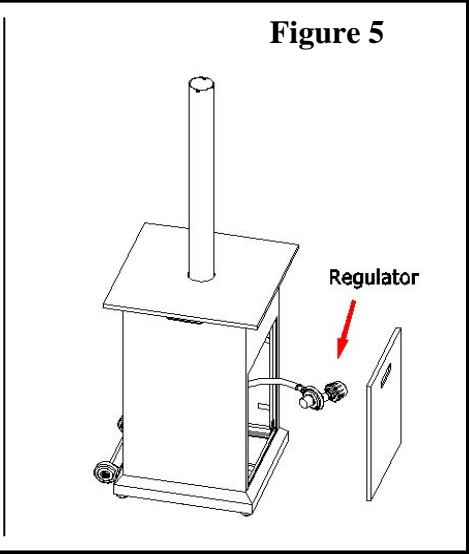
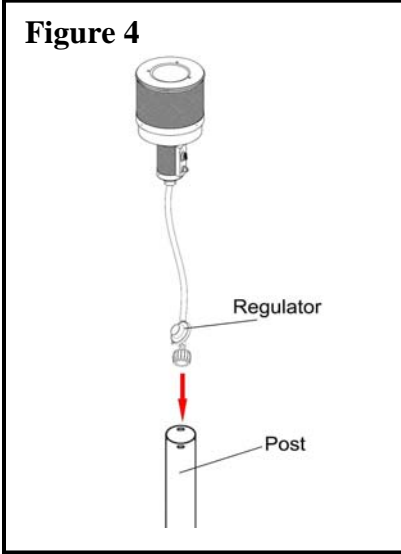
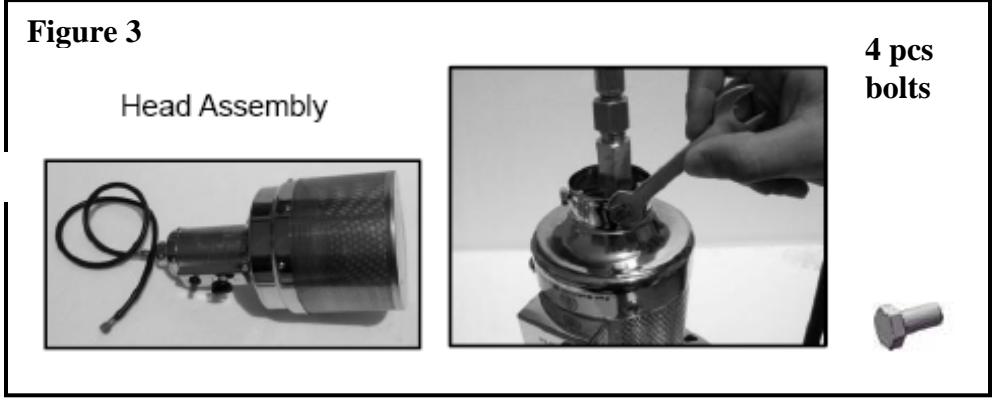

Step 3 –Attach Reflector Stud to Head Assembly

- Attach reflector stud (3pcs) and flat washers (3pcs) to the top of head assembly and tighten the bolts securely Please see **Figure 7**

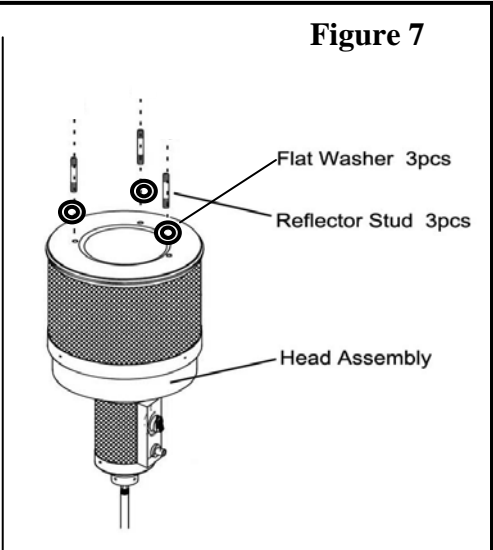
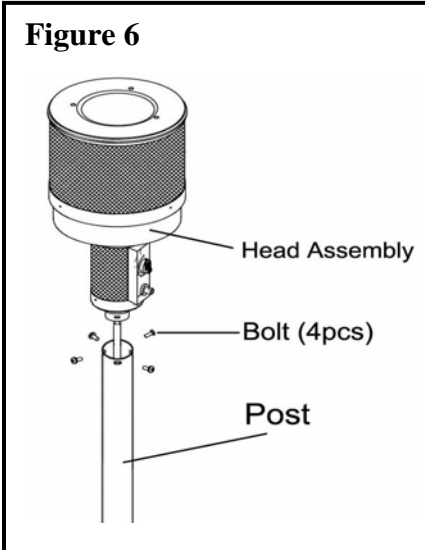

Step 4 –Attach Center Reflector to Reflector Panel. Figure 9

- Remove protective cover before assemble. Please see **Figure 8**
- Slide two reflector panels together. Please see **Figure 10**
- Insert one small screw and screw on cap nut loosely. Please see **Figure 10**
- Slide reflector plate onto reflector panels. **Figure 10**
- Insert one small screw and screw on cap nut loosely. **Figure 10**
- Repeat procedure to complete the assembly of all four sections. Fully tighten all of the screws. **Figure 9**

Figure 8

WARNING!

Remove protective cover before assemble.

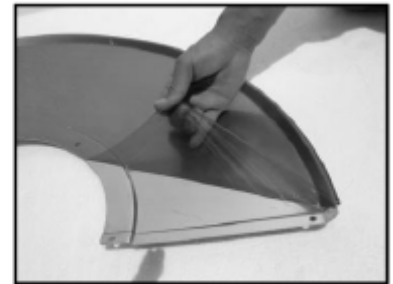
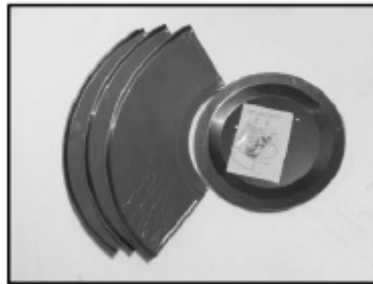

Figure 9

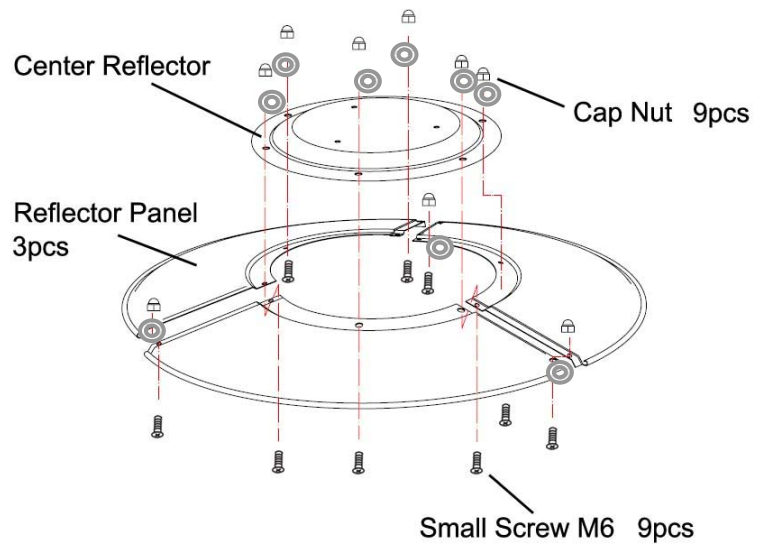
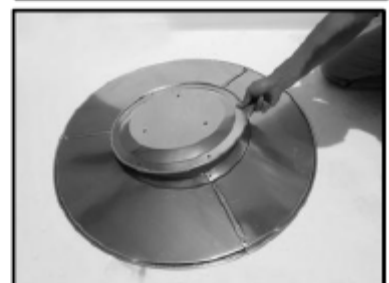
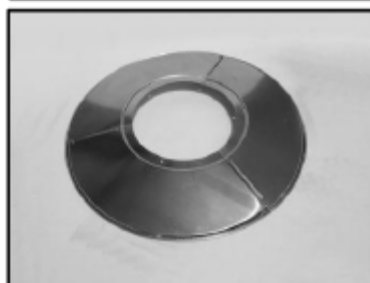
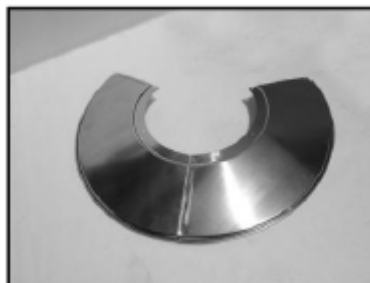

Figure 10



Step 5 –Attach Reflector Assembly to the top of Head Assembly

■ Attach reflector assembly to the top of head assembly by sliding over reflector stud (3pcs). Fasten with flat washers (6pcs) and wing nuts (3pcs). Please see **Figure 11**.

Figure 11

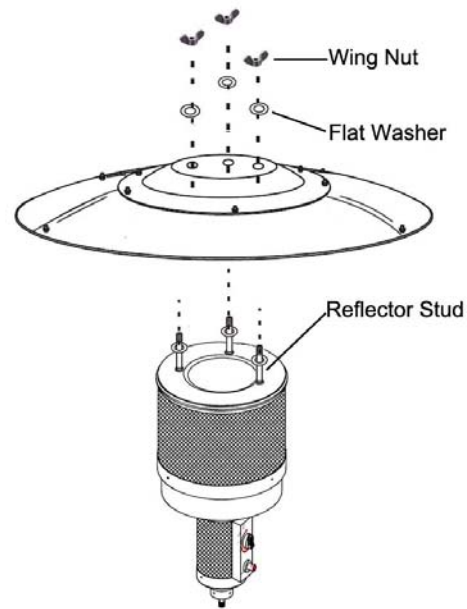

Connect Hose & Regulator to Cylinder

Step 1 – Gas Cylinder Required

- You must provide propane gas and propane cylinder. Use a standard 20lb. propane cylinder only.
- Use this heater only with a propane vapor withdrawal supply system. See Chapter 5 of the Standard for Storage and Handling of Liquefied Petroleum Gas, ANSI/NFPA 58. Your local library or fire department will have this book.
- Maximum supply pressure of 250 psi. A minimum supply pressure of 11.0 W.C. is required for the purpose of input adjustment for propane gas.
- The pressure regulator and hose assembly supplied with the appliance must be used.
- The installation must conform with local codes, or in the absence of local codes, with National Fuel Gas Code, ANSI Z223.1/ NFPA 54, Natural & Propane installation code, CSA B149.1 as applicable.
- A dented, rusted or damaged propane cylinder may be hazardous and should be checked by your cylinder supplier. Never use a propane cylinder with a damaged valve connection.
- The propane cylinder must be constructed and marked in accordance with the specifications for LP gas cylinders of the U.S. Department of transportation (DOT) or the Standard for Cylinders Spheres & Tubes for transportation of Dangerous Goods & Commission, CAN/CSA-B339, as applicable.
- Never connect an unregulated propane cylinder to the heater.
- Provided with a listed overfilling prevention device.
- Provided with a cylinder connection device compatible with the connection for the appliance.
- Do not store a spare LP-Gas cylinder under or near this appliance.
- Place the dust cap on the cylinder valve outlet when ever the cylinder is not in use. Only install the type of dust cap on the cylinder valve is provided with the cylinder valve.

Figure 12

20LB Propane Cylinder



Step 2 – Install Cylinder on the base.

- Put the gas cylinder in the metal stand. Make sure the gas tank sits on the metal stand completely. Turn the wing screw on the outer part of metal stand clockwise to secure the gas tank tightly. **Please see Figure 13**

Step 3 –Connect the Regulator to the gas cylinder valve.

- Turn the cylinder valve clockwise to close the gas supply on the gas cylinder. **See Figure 14**
- Screw Regulator Coupling clockwise by hand only. Make sure it is fastened. **See Figure 14**

Figure 13

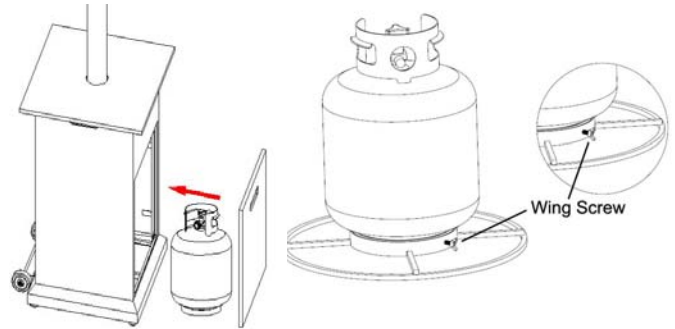
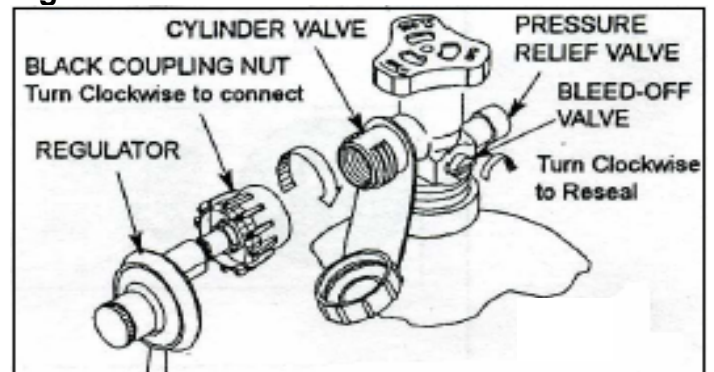

Figure 14



Check for leaks

Warning:

**Perform Leak test outdoors only.
Never leak test when smoking.
Do not use a flame to check for leaks.**

Your Patio Heater has been checked at all factory connections for leaks. To check the connection of the regulator/cylinder: **See Figure 15**

- Make leak solution by mixing 1 part liquid dish soap and 3 parts water.
- Brush several drops (or use spray bottle) of the solution onto the gas hose/regulator and regulator/cylinder connection.
- Turn on gas. Inspect the connections and look for bubbles.
- If no bubbles appear, the connection is safe.
- If bubbles appear, there is a leak, loosen and re-tighten this connection.

NOTE:

Whenever gas connections are loosened or removed, you must perform a complete leak test.

Figure 15



Regulator / Cylinder
Connection

Minimum clearances

BE CAREFUL: WHEN CERTAIN MATERIALS OR ITEMS ARE Stored, ABOVE, BESIDE OR UNDER THIS HEATER WHILE IN USE, THEY WILL BE SUBJECT TO RADIANT HEAT AND COULD BE SERIOUSLY DAMAGED.

- This heater is primarily used for the heating of outdoor patios, decks, and pool and spa areas. Always make sure that adequate fresh air ventilation is provided. Follow the spacing tolerances shown in **Figure 16**.
- The minimum clearances, shown in Figure 1, must be maintained at all times.
- This heater must be placed on firm level ground.
- Never operate in an explosive atmosphere. Keep away from areas where gasoline or other flammable liquids or vapors are stored or used.

Figure 16

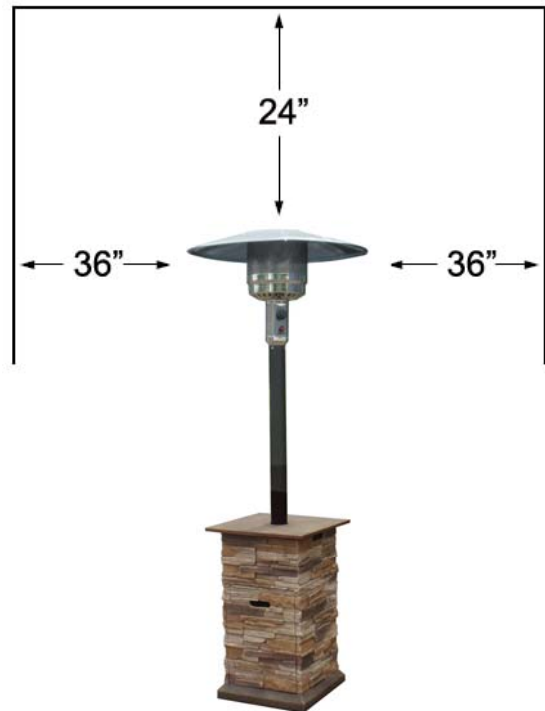

Operation

WARNING: DO NOT attempt to operate heater until you have read and understand all precautions. Failure to do so can result in serious personal injury, death or property damage.

Before Turning Gas Supply ON

Your heater was designed and approved for **OUTDOOR USE ONLY**. **DO NOT** use it inside a building, or any other enclosed area. Make sure surrounding areas are free of combustible materials, gasoline and other flammable vapors or liquids. Ensure that there is no obstruction to air ventilation. Be sure all gas connections are tight and there are no leaks. Be sure the access panel is clear of debris. Be sure any component removed during assembly or servicing is replaced and fastened prior to starting.

Before Lighting

Heater should be thoroughly inspected before each use and by a qualified service person at least annually. If relighting, always wait at least 5 minutes.

Lighting

Note: This heater is equipped with a Pilot Light that allows for safer startups and shutdowns. Pilot must be lit before Main Burner can be started.

- Open valve at gas cylinder.
- Open Viewing Hole by sliding cover to either side. (See Figure 18)
- Push Control Knob IN and rotate to Pilot position. (See Figure 17-1)

Note: For initial start or after any cylinder change, hold Control Knob IN for 2 minutes to purge air from gas lines before proceeding.

- While depressing control knob, press spark igniter button to light up Pilot. And be visible through Viewing Hole.
- Release Control Knob after 30-60 seconds. Pilot Light will remain lit. If not, return to step 1.
- Turn Control Knob to LO or HI position. (See Figure 17-2) Main Burner will light immediately. Flame is visible through Viewing Hole. If not, return to step 1.

WARNING: If spark igniter fails to light the pilot after 30 seconds, release control knob, turn to “OFF” position (See Figure 20) , all valves should be closed and wait 5 minutes before relight.

- If for some reason your spark igniter fails to deliver a spark, your heater can be started by inserting a lit match through the viewing hole (See Figure 19) while pushing the control knob in while in the “PILOT” position(See Figure 17-1).

Figure 17-1

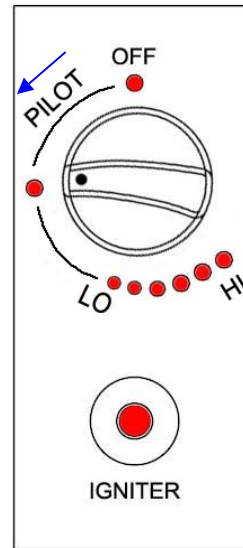

Figure 17-2

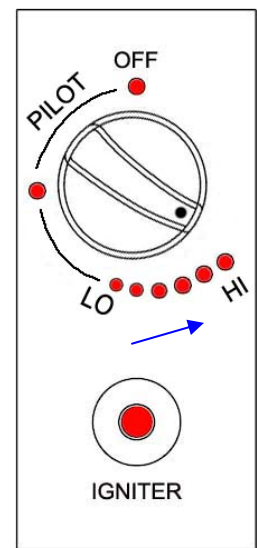

Figure 18 Viewing Hole

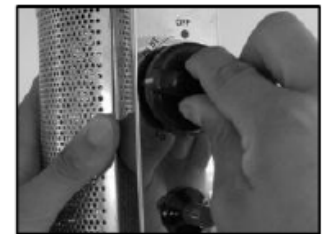
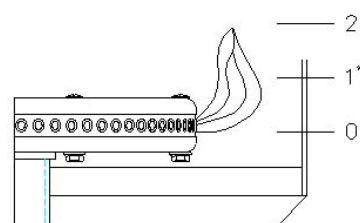
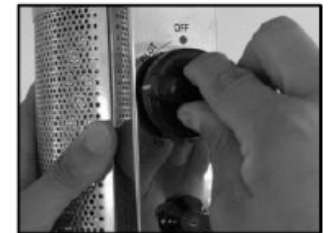

Figure 19 Match lighter



Observe the flame pattern

When heater is ON:

- When lit for the first time the heater may emit a slight odor and smoke. This is a normal temporary condition caused by the “burn in” of paints and lubricants used in the manufacturing process and will not occur again. Simply run the heater on “high” for 30 minutes.
- Emitter screen will become bright red due to intense heat. The color is more visible at night. Burner will display tongues of blue flame. These flames should not be yellow or produce thick black smoke, indicating an obstruction of airflow through the burners.

Never leave the heater unattended while in use.

Shut down

- Turn Control Knob clockwise to Pilot. (Normally, burner will make a slight popping sound when extinguished.) Burner will extinguish but Pilot will remain ON.
- To extinguish Pilot, depress Control Knob and continue to turn it clockwise to OFF. (See Figure 20).
- Turn off gas supply at the valve of gas cylinder.
- Disconnect the cylinder and remove when the heater is not in use.

Figure 20

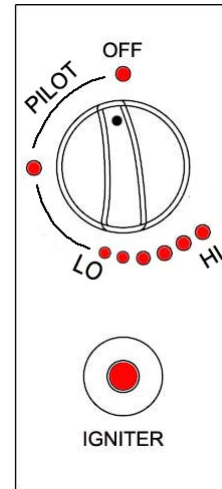

Storage

Note: Wait until heater is cool before covering.

When heater is not in use for a prolonged period of time, remove gas cylinder.

Verify that the gas cylinder valve is closed tightly.

Do not store the gas cylinder indoors, store gas cylinder in a well ventilated area.

Maintenance

To obtain the best performance from your heater make sure you perform the following maintenance activities on a regular basis:

- Keep exterior surfaces clean. Use warm soapy water for cleaning. Never use flammable or corrosive cleaning agents. Be sure to keep the area around the burner and control assembly dry at all times.
- Keeping the ventilation openings of the cylinder enclosure free and clear from debris. Visually checking burner flames with pictorial representations shown on page 11.
- Airflow must be unobstructed. Clear insect nests or webs away from your heater's exterior and interior using a straight piece of wire and wire brush or vacuum cleaner at least once a year or immediately upon indication of any of the following systems:
 - a. Flashback
 - b. Smell the fuel gas
 - c. Predominate yellow flames
 - d. Excessive popping noises during operation
 - e. Uneven emitter glow

Carbon deposits may create a fire hazard. Clean dome and emitter with warm soapy Water if necessary.

Caution:

Never use wood or plastic, it may break and block the parts.

Never spray any cleaning product on the emitter grid or burner area.

Troubleshooting and replacement parts

To learn how to service and procure parts for worn out, defective or damaged components which shown in below list need replace please contact your selling dealer or call us directly for assistance. Please provide us with heater's model number and the serial number.

Warning: Use our original equipment replaced parts only. Use unauthorized parts or modification of parts can void warranty and create an unsafe condition.

PROBLEM	PROBABLE CAUSE	SOLUTION
Pilot will not light	Gas valve may be OFF	Turn the gas valve ON
	Gas Cylinder empty	Refill LP gas cylinder
	Orifice blocked	Clean or replace orifice
	Air in supply system	Purge air from lines, with knob in pilot position, depress and hold in, to release air.
	Loose connection	Check all fittings
	Igniter is not sparking	Use match to light pilot; obtain new igniter and replace
Pilot will not stay on	Debris around pilot	Clean dirty area
	Thermocouple bad	Replace thermocouple
	Gas leak in line	Check connections
Burner won't light	Pressure is low	Refill or replace LP gas cylinder
	Orifice blocked	Remove, clean and replace
	Thermocouple is bad	Replace thermocouple
	Pilot light assembly bent or not in correct location	Place pilot in proper position and retry
Burner flame is low	Gas pressure is low	Turn cylinder valve OFF and replace cylinder
	Outdoor temperature is less than 40°F and tank is less than 1/4 full	Use a full cylinder
	Supply hose is bent or kinked	Straighten hose
Carbon build up	Dirt or film on reflector and burner screen	Clean reflector and burner screen

Thick black smoke	Blockage in burner	Remove blockage and clean burner inside and outside
--------------------------	--------------------	---

Service

- A hazardous condition may result if a heater is used that has been modified or is not functioning properly. When the heater is working properly:
 - The flame is contained within the heater.
 - The flame is essentially blue.
 - There is no strong disagreeable odor, eye burning or other physical discomfort.
 - There is no smoke or soot internal or external to the heater.
 - There is no unplanned or unexplained shutdown of the heater.
 - There is no Flashback.
 - There are no excessive popping noises during operation.
 - There is no diminished and uneven emitter glow.

The parts list shows the heater as it was constructed. Do not use a heater, which is different from that shown. In this regard, only the cylinder connections and regulator supplied with the heater. Do not use alternative parts. For this heater the regulator is set for 11.0" water column outlet pressure. If there is any uncertainty about the regulator setting, have it checked. A heater that is not working properly must be repaired, but only by a trained, experienced service person.

- If your heater needs maintenance or is not working properly, please contact your local authorized agent for service. It is a necessity to contact an authorized source for replacement of parts and/or other servicing.

IF YOU HAVE QUESTIONS OR CONCERNS
PLEASE CALL BOND TOLL FREE #
1-866-771-BOND(2663) OR TO BETTER
EXPEDITE YOUR REQUEST FEEL FREE TO EMAIL US
customerservice@bondmfg.com
OR LOG IN TO OUR WEBSITE UNDER CUSTOMER SERVICE SUPPORT
www.bondmfg.com
BOND MANUFACTURING CO.
1700 West 4th Street Antioch, CA 94509 USA