

# USER'S MANUAL

IM-EESIFLO

ELECTRONICS EDITION JUL 2007



## PORTABLE ULTRASONIC FLOWMETER EESIFLO PORTALOK 7S



# USER'S MANUAL

IM-EESIFLO

ELECTRONICS EDITION JUL 2007



## Introduction

### Regarding this Manual

This manual has been written for the personnel operating EESIFLO Portalok 7S series flowmeter. It contains very important information about the instrument, how to handle it correctly, how to avoid damaging it and how to avoid injury. Always keep this manual at hand. Get acquainted with the safety rules and the handling precautions. Make sure you have read and understood this manual before using the instrument. All reasonable effort has been made to ensure the correctness of the content of this manual. Should you however find some erroneous information, please inform us.

Please note that we shall be grateful for any suggestions and comments regarding this product. This will ensure that we can further improve our products for the benefit of our customers and in the interest of technological progress.

Should you have any suggestions about improving the documentation and particularly this User's Manual, please let us know so that we may consider your comments for future reprints.

We also provide special customer solutions and will be pleased to advise you in using EESIFLO for specific applications and finding the most appropriate solution for your measurement problem. Please log onto our website [www.eesiflo.com](http://www.eesiflo.com) for contact details.

The content of this manual may be changed without prior notice. All rights reserved. No part of this manual may be reproduced in any form without EESIFLO's written permission.

### Safety Precautions

This manual contains the following safety information:

<b>Note:</b>	The notes contain important information which help you use your instrument in an optimal way.
--------------	---

<b>Attention!</b>	This text gives you important instructions which should be followed in order to avoid damage or destroy the instrument. Proceed with attention!
-------------------	---

	This text denotes an action which could result in injury or death of personal. Proceed cautiously!
---	--

**Follow these safety precautions!**

# USER'S MANUAL

IM-EESIFLO

ELECTRONICS EDITION JUL 2007

---



## Warranty

The EESIFLO Portalok 7S series flowmeter is guaranteed for 12 months from date of purchase provided the equipment has been used for the purpose for which it has been designed and operated according to the instructions given in the present User's Manual. Misuse of the EESIFLO meter will immediately revoke any warranty given or implied. This includes:

- the replacement of a component of the EESIFLO by a component that was not authorized by **EESIFLO**;
- Unsuitable or insufficient maintenance;
- Repair of the EESIFLO by unauthorized personnel.

**EESIFLO** assumes no responsibility for injury to the customer or third persons caused by the material owing to defects in the product which were not predictable or for any indirect damages.

The EESIFLO Portalok 7S series is a very reliable instrument. It is manufactured under strict quality control, using modern production techniques. If installed correctly, as recommended, the Portalok 7S will be an invaluable tool for flow measurement. If you are unable to resolve any technical issues with the help of this manual, please contact our office, giving a precise description of the problem.

# USER'S MANUAL

IM-EESIFLO

ELECTRONICS EDITION JUL 2007



---

## The Portalok 7S Flowmeter

### Overview

**EESIFLO Portalok 7S** is a flowmeter that uses ultrasonic signals to measure the flow in pipes or conduits filled with liquid. It can measure the following quantities:

- flow velocity;
- volume and total flow;
- sound velocity of a medium.

The transducer's recommended temperature operation is between  $-30^{\circ}\text{C}$  and  $100^{\circ}\text{C}$  and for short periods, up to  $130^{\circ}\text{C}$ . Measurement can be made on all commonly used pipe materials such as steel, synthetic material, glass or copper. Recommended pipe diameters may range from 1 inch (25mm) up to 40 inches (1000 mm) with the standard transducers. The two clamp-on transducers allow for non-invasive measurement that does not affect the pipework or the liquid to be measured. They are small, lightweight and easy to install.

**PORTALOK 7S** is a portable ultrasonic flow meter and operates with an external power supply 100...240 VAC or 6 VDC internal batteries. The Portalok 7S is a waterproof flow meter and has a protection degree IP68 when its cover is closed. It is therefore suitable for monitoring tasks under difficult environmental conditions.

**Portalok 7S** has a backlit display which shows input data and measurement results as well as operational errors. The menu guide the user through the parameter setup and the measurement.

An internal data bank contains the properties of many materials and media which may be selected to suit the application.

# USER'S MANUAL

IM-EESIFLO

ELECTRONICS EDITION JUL 2007



## Measuring Principle

EESIFLO uses ultrasonic signals for the measurement of liquid flow, employing the so-called **transit time** method. Ultrasonic signals are emitted by one transducer installed on one side of a pipe, reflected on the opposite side and received by a second transducer. These signals are emitted alternatively in the direction of flow and against the flow

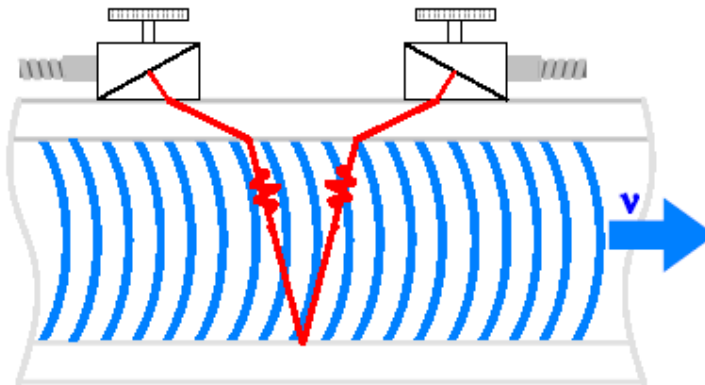

Transit path of the ultrasonic signals

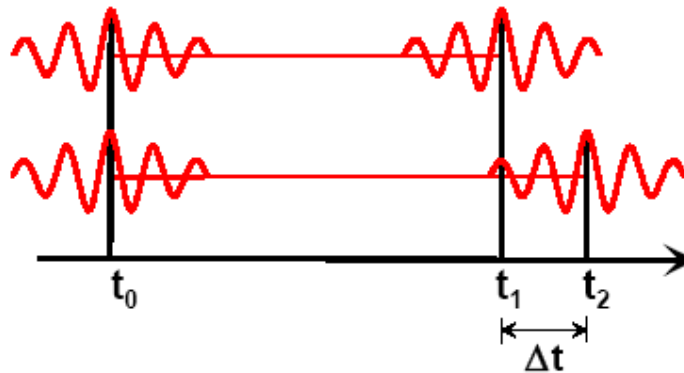
Transit-time difference  $\Delta T$ 

When the medium is flowing, the transit time of the sound signals propagating in the direction of flow is shorter than the transit time of the signal propagating against the direction of flow.

The transit-time difference  $\Delta T$  is measured and allows the determination of the average flow velocity on the propagation path of the ultrasonic signals. A profile correction is then performed to obtain the average flow velocity on the cross-section of the pipe, which is proportional to the volume flow rate.

# USER'S MANUAL

IM-EESIFLO

ELECTRONICS EDITION JUL 2007

---



The Portalok 7S diagnoses the incoming ultrasonic signals and evaluates the plausibility of the measured values. The integrated microprocessors control the complete measuring cycle, eliminating disturbance signals by statistical signal processing techniques.

## Portalok 7S Applications

The Portalok 7S can be used where the pipe wall and the liquid to be measured are sonically conductive. This is true for pipe walls consisting of homogeneous material, and for liquids which carry only small amounts of solid particles or gas bubbles. Since ultrasonic waves also propagate in solid materials, the transducers can be mounted outside the pipe, allowing for non-invasive measurement.

The transit time difference effect can be observed over the complete range of flow velocities found in many applications. Furthermore, it is independent of the electrical parameters of the fluid (conductivity, dielectric constant, etc.). The Portalok 7S is thus a very versatile instrument.

### Advantages:

- Non-invasive method permits safe measurement on aggressive or high temperature media flowing in closed conduits.
- Flow values can be measured without interruption of the process.
- The installation does not require any alterations to the pipe system.

# USER'S MANUAL

IM-EESIFLO

ELECTRONICS EDITION JUL 2007



## Description of the Flowmeter

### Control Panel of the Portalok 7S

**Attention!** The protective degree IP68 is only effective when the meter lid is fully shut.

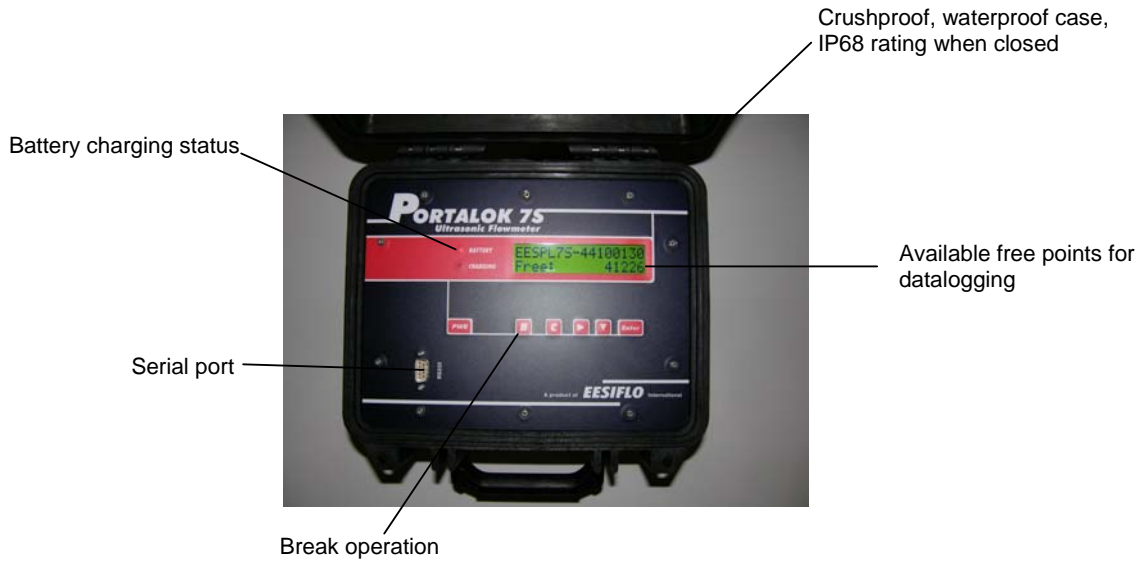

**Top panel of Portalok 7S - Batteries are located inside the unit. They can be accessed and replaced by removing the top panel.**

See labels for transducer connection

See labels for output connection

See labels for power supply connection



# USER'S MANUAL

IM-EESIFLO

ELECTRONICS EDITION JUL 2007



---

## The Transducers

The transducers are mounted correctly if the engravings on the two transducers together form an arrow. The transducer cables should then show in opposite directions.

The arrow, in conjunction with the displayed measured value, will help you to determine the direction of flow.

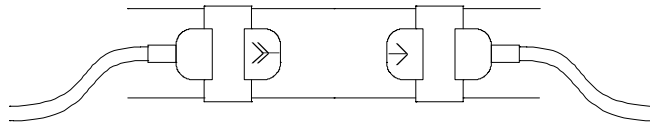

**Correct positioning of the transducers with the arrow in the direction of the flow**

<b>Note:</b>	The engraving should also form an arrow if the two transducers are mounted on opposite sides of the pipe wall.
--------------	--

## Serial Number

Model and serial number are indicated on the lid-cover in the flowmeter. When contacting EESIFLO, always have both numbers at hand. If the serial number is lost, the number can be obtained from the start up screen.

# Handling

## Scope of Delivery

On delivery, please make sure that all items of the following list (standard scope of delivery) are in the package:

- 1 User's manual
- 1 Portalok 7S in IP 68 case including power supply and cable (output cable is optional)
- 1 Set of 2 transducers as per order, with integrated cables
- 2 Transducer mounting fixtures with tension straps/chains
- 1 Tube of acoustic coupling compound

Your package may contain other components according to your particular order.

Model designation and serial number are given on the data plate of the flowmeter. When contacting EESIFLO, always have both of them at hand,

### General Precautions

The Portalok 7S is a precision measuring instrument and it must be handled with care. To obtain good measurement results and in order not to damage the instrument, it is important that attention is paid to the instructions given in this User's Manual, and particularly to the following points:

- Protect the instrument from excessive shock.
- Keep the transducers clean.
- Do not drop transducers from heights
- The protective degree IP68 of **Portalok 7S** is given only if the lid is closed
- Connect the flowmeter correctly to the mains power supply if not using battery power
- Work under correct ambient conditions (see specifications). Do not exceed IP 68 protection.

## Maintenance

No maintenance work is necessary. Always follow the handling precautions and the instructions given in this manual. The Portalok 7S will provide trouble free service if installed correctly, in an appropriate location and used as recommended.

## Cleaning

Clean the instrument with a soft cloth. Do not use detergents. Remove traces of acoustic coupling compound from the transducers with a paper tissue.

# Installation of EESIFLO the Portalok 7S

## Location

, STEP 1 :Select the measuring point according to the recommendations given in this manual. Ensure that the temperature at the selected location is within the operating temperature range of the transducers.

STEP 2, Select a location that is within cable reach from the measuring point to the transmitter. Ensure that the temperature at the selected location is within the operating temperature range of the transmitter.

## Setting-up

### Connection of the Transducers

**Attention!** The IP 68 protective degree of the flowmeter is only guaranteed if all cables are connected firmly and tightly to the weatherproof connectors on the flowmeter. The top plate should be tightly screwed to the housing.

### Connection of the power supply and Battery Charging

110/VAC or 220/VAC – Do not connect the meter to incorrect voltages when charging.

The Portalok 7S will run approximately 24 hours on battery power when fully charged. Do not overcharge the unit. 24 hours usage will require approximately 24 hours charging time.

The Portalok 7S has two status LED's which display status information about the battery and the battery charging process.

**BATTERY** LED has three states:

**ON** – The charge of the battery is more than 20 percent but less than 50 percent.

**OFF** – The charge of the battery is more than 50 percent.

**BLINKING** – The charge of the battery is less than 20 percent.

**CHARGE** LED also has three states:

**ON** – The instrument is connected to a power supply. The battery is fully charged.

**OFF**- The instrument is not connected to a power supply. The battery is not being charged.

**BLINKING**- The instrument is connected to a power supply. The battery is being charged.

#### BATTERY REPLACEMENT PROCEDURE

Replacing the battery requires careful removal of the control panel cover screws and panel.

Please note the following:

**ONLY USE BATTERY PACKS SUPPLIED BY EESIFLO TO ENSURE GUARANTEED PERFORMANCE AND TO AVOID DAMAGE TO THE INSTRUMENT.**

## Connection of the Process Outputs

<b>Attention!</b>	The IP 68 protective degree of the flowmeter is only guaranteed if all cables are connected firmly and tightly to the weatherproof connectors on the flowmeter. The top plate should be tightly screwed to the housing.
-------------------	---

The optional output connector to send signals to remote devices consists of a cable with 6 flying leads. Each lead has been numbered. Please refer to the table for information for wiring purposes.

### Labels for the connection of the process outputs

Connection
Binary output B1
Binary output B2
Current loop I1

If you have purchased an optional output cable, please refer to the labels attached to the actual cables for identification.

Circuits of the process outputs

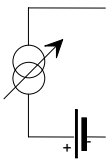
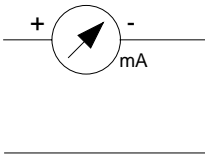
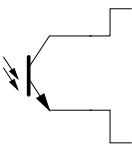
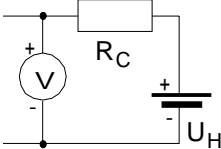
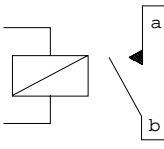
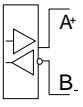
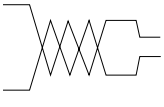
OUTPUT	EESIFLO	CIRCUIT	
Current loop (active)			$R_{LOAD} < 500 \Omega$
Binary output (Open-Collector)			$U_H = (5 \text{ to } 24) \text{ V}$ $R_C [k\Omega] = U_H / I_C [mA]$ $I_C = (1 \text{ to } 4) \text{ mA}$
Binary output (Reed-Contact Relay)			$U_{MAX} = 24 \text{ V}$ $I_{MAX} = 150 \text{ mA}$
RS485 (optional and not standard)			(one $120\Omega$ termination resistor) <b>NOT APPLICABLE IN THIS VERSION</b>

# Getting Started- Instrument Start-Up

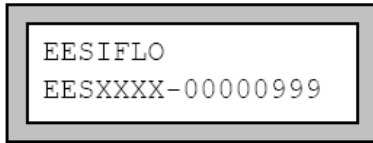

Turn power on by pressing PWR, a message EESIFLO will appear for several seconds along with the serial number of the instrument..

**Note!** No data can be entered whilst the serial number is displayed.

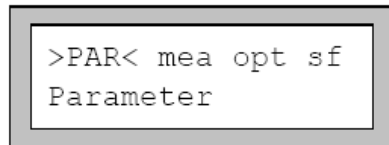

On start up the >Par< (Parameter) mode is indicated. If you have previously been doing measurements the >mea< ( Measurement) screen will appear.

## The Keyboard









The operator interface of the Portalok 7S consists of 6 keys including power switch



Keyboard of EESIFLO Portalok 7S

### Key operations

General functions	
	Power and the backlight are controlled by the PWR power button. To switch the instrument ON, briefly press the PWR button. To switch the backlight on and off, press the PWR button briefly. To switch the instrument OFF, press the PWR button for at least 3 seconds.
	Confirm selection or entered value.
	Cancel selection or edition and return to the main menu. Similar to Esc and is used at any time a wrong entry is made
	RESET: Press these keys simultaneously to recover from an error. This has the same effect as restarting the unit. Similar to Ctrl, Alt Del Data will not be affected.
	UNIT (cold-start): Pressing these keys simultaneously while switching the flowmeter ON until the MAIN MENU appears will initialize EESIFLO. Most parameters and settings are reset to the factory default values. The memory will not be cleared.
Horizontal selection	
	Select next item on the right (wrap after rightmost item).



	Select next item on the left (wrap after leftmost item).
<b>Vertical selection</b>	
	Scroll forward (wrap after last item).
	Scroll backward (wrap after first item).
<b>Input of numerical values</b>	
	Move cursor to the right.
	Scroll digit above cursor.
	Move cursor to the left. When the cursor is on the left margin: - an already edited value will be reset to previously saved value - an unedited value will be deleted. If the entered value is not valid, an error message will be displayed. Press any key and enter a correct value.
<b>Input of text</b>	
	Move cursor to the right (wrap after rightmost item).
	Scroll through character set above cursor.
	Reset all characters to last saved entry.

## The Menu

### The Main Menu

```
>PAR< mea opt sf
Parameter
```

After switching on and initialization, the main menu appears on the first line of the display. The main menu has following entries: PAR (parameter), MEA (measuring), OPT (output options) and SF (special functions), corresponding to the four different program branches. The selected program branch is displayed in capital letters between arrows. The full name of the program branch is displayed on the second line.

Use keys  and  to select a program branch. Confirm your selection by pressing **ENTER**.

### The Program Branches

In the **PARAMETER** program branch, you can enter the parameters of the pipe and of the medium.

The **MEASURING** program branch leads you through the different steps of the measuring process.

In the **OUTPUT OPTIONS** branch, you can set all relevant output parameters, such as the physical quantity to be displayed during measurement and the measurement units.

The SPECIAL FUNCTION branch contains all functions that are not directly related with the basic measurement.

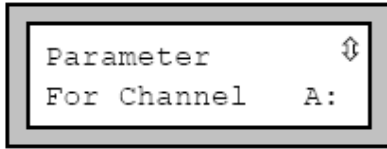

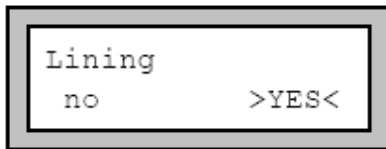

If a vertical arrow (⇅) is displayed beside a menu option, this menu contains a scroll list. This list is displayed on the second line.

Use the arrow keys  and  to scroll through the list, then confirm your selection by pressing **ENTER**.



Portalok 7S sometimes requests a selection on the second line. The selected option is displayed in capital letters between arrows.

Use keys  and  to select one of the options, then confirm your selection by pressing **ENTER**.

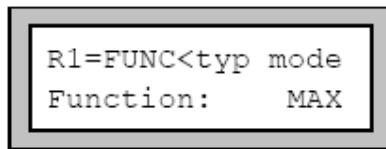

The Portalok 7S sometimes requests a horizontal selection between different menus on the upper line of the display. The selected menu is displayed in capital letters between arrows. The selected options of the menus are displayed on the second line.

Use key  to select one of the menus.

Use the arrow key  to scroll through the selected menu.

**Note:** You can return to the main menu at any time by pressing key  (Esc)

**Note:** In this manual, all program entries and keys will appear in capital letters. Program entries are in typewriter characters ("PARAMETER"). Submenus are separated from the main menu entry by a backslash.

## Command Execution during Measurement

Commands that can be executed during measurement are shown on the upper line of the display. A command line always begins with a →. Scroll on the upper line of the display with key  until the required command is displayed. Confirm your selection with **ENTER**. Depending on the instrument's settings, an authorization code might have to be entered; example - the user is required to use the instrument outside of its recommended measurement range. A list of the commands available during measurement is given in the HOT CODE section.

## HotCodes

A HotCode is a specific key sequence which has to be entered to activate special settings. The Portalok 7S is a very powerful instrument but certain settings are purposely locked to avoid misapplication in the field.



```
SYSTEM settings ↕
Miscellaneous
```

To enter a HotCode, select the program branch >Sf<  
SPECIAL FUNCTIONS\SYSTEM SETTINGS\  
MISCELLANEOUS.

```
Input a HOTCODE
no >YES<
```

Select YES to enter a HotCode.

Use HotCodes only when instructed by EESIFLO for certain applications

```
Please input a
HOTCODE: 000000
```

Enter the required HotCode. Confirm with **ENTER**.

```
INVALID HOTCODE
HOTCODE: 000000
```

If an invalid code is entered, an error message is displayed. Press any key to continue.

```
Input a HOTCODE
no >YES<
```

Select YES to continue or NO to go back to the MISCELLANEOUS menu.

## Interruption of Power

EESIFLO stores the last measurement parameters in a non-volatile coldstart resistant EPROM as soon as the measurement begins.

Previous input data and measuring parameters are preserved.

```
EESIFLO
EESXXXX-00000999
```

If the unit is accidentally turned off, the serial number of the instrument appears briefly on the display when the power is restored

The Portalok 7S automatically continues the measurement **when power is restored**. All selected output options will also be active.

The flowmeter does not continue the measurement after return of the power supply if a coldstart was performed.

To perform a coldstart, press **BRK, C** and **ENTER** simultaneously, then let the **BRK** and **C** keys pressed and release **only** the **ENTER** key. The instrument will be restarted. Do not release **BRK** and **C** before the main menu is displayed.

# Selection of the Measuring Point

The correct selection of the measuring point is crucial for achieving reliable measurements and a high accuracy. Measurements must take place on a pipe where:

- Sound can propagate and in which a fully developed rotationally symmetrical flow profile is observed.

The correct positioning of the transducers is essential for error-free measurement. It guarantees that the sound signal will be received under optimal conditions and evaluated correctly. Because of the variety of applications and the different factors influencing measurement, there can be no standard solution for the positioning of the transducers. The correct position of the transducers will be influenced by the following factors:

- the diameter, material, lining, wall thickness and form of the pipe;
- the medium flowing in the pipe;
- the presence of gas bubbles in the medium.

Ensure that the temperature at the selected location is within the operating temperature range of the transducers

Select the location of the instrument within cable reach of the measuring point. Ensure that the temperature at the selected location is within the operating temperature range of the transmitter.

## Acoustic Propagation

Acoustic propagation can be assumed when pipe and medium do not attenuate the sound so strongly that the signals are completely absorbed before reaching the second transducer. The level of sound attenuation in a specific system depends on:

- the kinematic viscosity of the liquid,
- the proportion of gas bubbles and solid particles in the liquid,
- the presence of deposits on the inner pipe wall,
- the wall material.
- Temperature

Ensure that following conditions are fulfilled at the measuring point:

- the pipe is always full
- no material build up.
- no bubbles accumulate (even bubble-free liquids can form gas pockets where the liquid expands, e.g. especially after pumps and where the cross-sectional area of the pipe is not uniform).

## Undisturbed Flow Profile

Many flow elements (elbows, slide valves, valves, pumps, T-sections, reducers, diffusers, etc.) distort the flow profile in their vicinity. The axi-symmetrical flow profile required for correct measurement may therefore influence flow measurements. A careful selection of the measuring point will reduce the impact of disturbance sources.

**It is most important that the measuring point is chosen at a sufficient distance from any disturbance sources. Only then can it be assumed that the flow profile in the pipe is fully developed.**

The Portalok 7S will however provide good results even under non-ideal measuring conditions.

In the following examples, recommended straight inlet and outlet pipe lengths are given for different types of flow disturbance sources to assist in selecting the correct measuring point. This may not always be possible but should be used as a guide.

**Recommended distance from disturbance source:**  
(D = nominal pipe diameter at measuring point, L = recommended distance)

**Disturbance source: 90°-elbow**

Inlet

$L \geq 10 D$

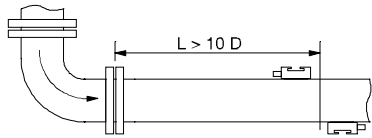

Outlet

$L \geq 5 D$

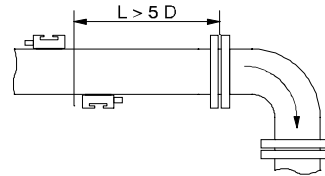

**Disturbance source: 2 x 90°-elbows in one plane**

Inlet

$L \geq 25 D$

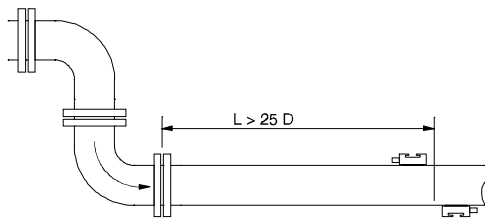

Outlet

$L \geq 5 D$

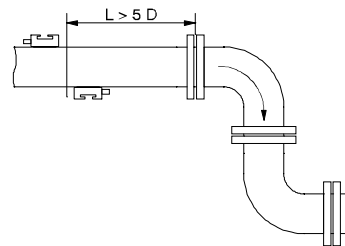

**Disturbance source: 2 x 90°-elbows in different planes**

Inlet

$L \geq 40 D$

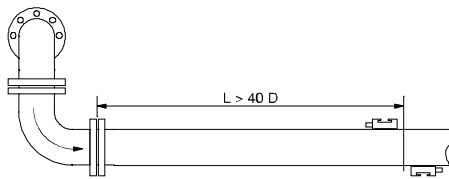

Outlet

$L \geq 5 D$

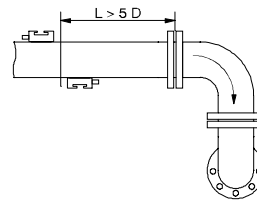

**Disturbance source: T-section**

Inlet

$L \geq 50 D$

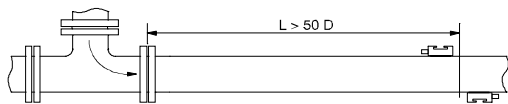

Outlet

$L \geq 10 D$

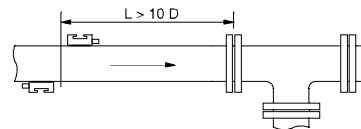

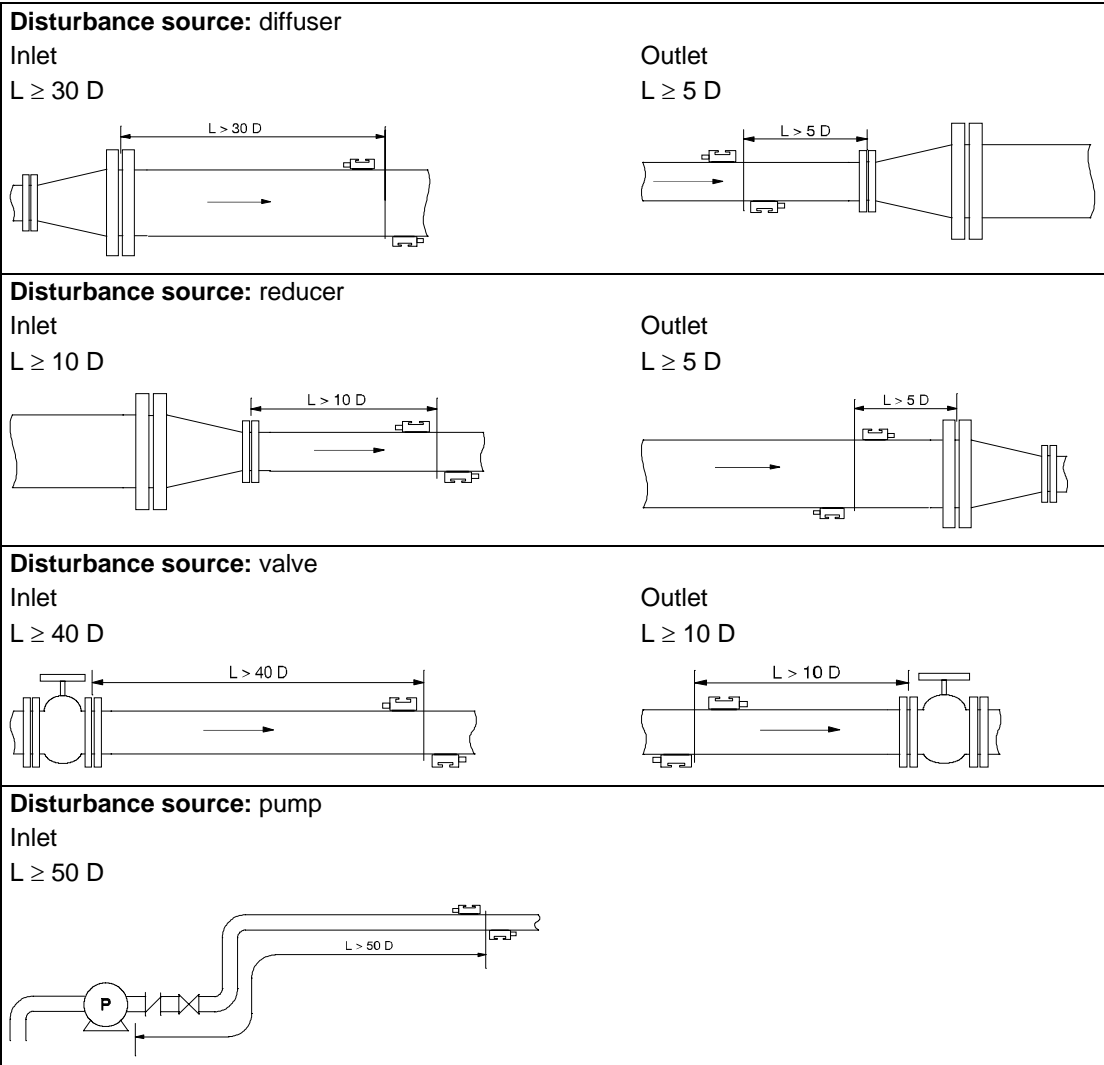

# Points to Avoid

Avoid measuring locations:

- in the vicinity of deformations and defects of the pipe;
- or in the vicinity of welding;
- where deposits have formed in the pipe ie: lime scale, calcium build up..

## Points to avoid

### For an horizontal pipe:

Select a location where the transducers can be mounted on the side of the pipe, so that the sound waves emitted by the transducers propagate horizontally in the pipe. Thus, the solid particles deposited on the bottom of the pipe and the gas pockets developing at the top won't influence the propagation of the signal.

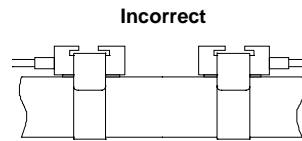
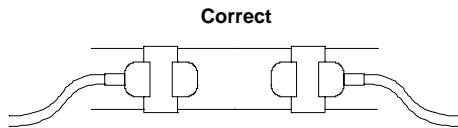

### For a free inlet or outlet pipe section:

Select the measuring point at a location where the pipe cannot run empty.

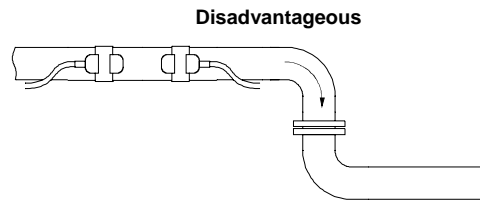
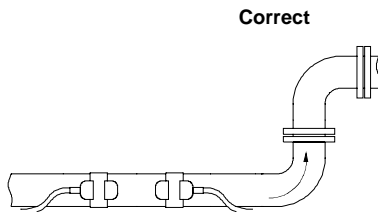
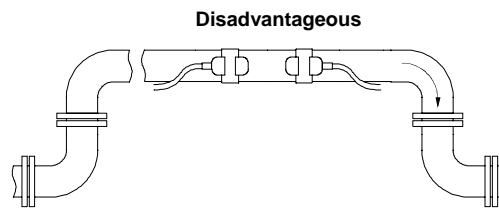
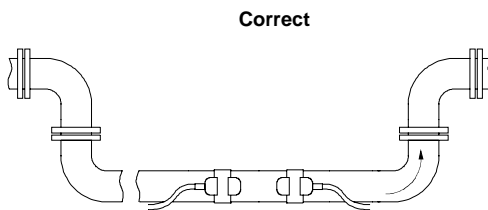

### For a vertical pipe:

Select the measuring point at a location where the liquid flows upward. The pipe must be completely filled.

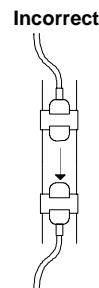
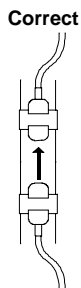

# Basic Measurement

Once the measuring point has been selected, the parameters of the pipe and of the medium can be entered. They can be modified at any time later by pressing **B** and then accessing `PARAMETER` again.

## Input of the Pipe's Parameter

The parameters of the pipe now have to be entered for every measuring point.

```
Outer Diameter
1100.0 MAXIMUM
```

(Example)

The values that can be given to the parameters of pipe and medium are limited by the characteristics of transmitter and transducers. Refer to the Portalok specifications if you are not sure of these limits.

In some instances the entered outer diameter may be too big. In this case, the instrument might display the maximal possible value for this parameter (1100.0 mm in the case of standard transducers and a pipe with a wall thickness of 50 mm).

**Note:** The Portalok 7S only accepts the parameters if all the values have been entered in `PARAMETER`.

The pipe parameters that you will now enter can be modified at any time in `PARAMETER`.

```
>PAR< mea opt sf
Parameter
```

In the main menu by pressing **B**, select the program branch `PARAMETER` and press **ENTER**.

## Pipe Outer Diameter / Circumference

```
Outer Diameter
100.0 mm
```

Enter the outer diameter of the pipe.

Confirm your entry or the displayed value by pressing **ENTER**.

It is possible to change this menu in order to enter the pipe circumference instead of the diameter. This setting is coldstart resistant and can be made in the program branch `SPECIAL FUNCTION`

If the input of the pipe circumference is activated and you inadvertently enter a 0 (zero) in the `OUTER DIAMETER` display, the Portalok 7S will switch to the `PIPE CIRCUMFER.` display. If you do not wish to enter the pipe circumference, press **B** to return to the main menu and start the parameter input again.

## Wall Thickness

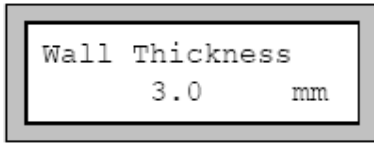

```
Wall Thickness
  3.0      mm
```

Enter the pipe wall thickness. The range of possible values depends on the transducer specifications. Default value for this parameter is 3.0 mm.

Confirm by pressing **ENTER**.

If you do not have reliable wall thickness information from known pipe specifications, you may need to measure the wall thickness on site with a non contact thickness gage.

If you do not have a separate pipe wall thickness gage, please contact EESIFLO for the model WTG-EES-01 stand alone ultrasonic thickness gage or purchase one from a local vendor.

**Note:** The Portalok calculates the inner diameter (outer diameter - 2 x wall thickness) and checks if this value is within the specified inner diameter range for the transducers used. An error message is displayed if this is not the case. It is possible to modify the value of the minimal pipe inner diameter accepted by the Portalok 7S for a certain type of transducer. Contact EESIFLO for the HOTCODE

## Pipe Material

The pipe material now has to be selected in order to determine its sound velocity. The nominal sound velocities of the materials of the selection list are already programmed in the instrument. When the pipe material is selected, the Portalok 7S sets the sound velocity automatically.

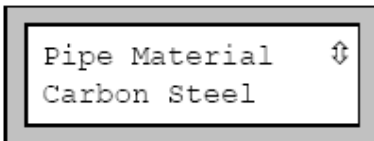

```
Pipe Material ↕
Carbon Steel
```

Select the pipe material in the pipe material selection list. If the correct material is not listed, select the entry **OTHER MATERIAL**.

Confirm by pressing **ENTER**.

**Note:** It is possible to select which materials are to be displayed in the material selection list..

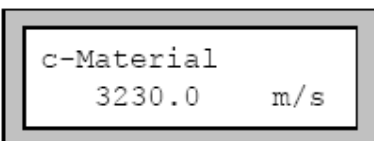

```
c-Material
 3230.0   m/s
```

If you have selected **OTHER MATERIAL**, the Portalok 7S requests the entry of the sound velocity. Enter the sound velocity of the pipe material. Values between 600.0 and 6553.5 m/s are accepted. Confirm by pressing **ENTER**.

**Important!** Enter the sound velocity of the material (longitudinal velocity or transversal velocity) which is nearer to 2500 m/s.

## Pipe Lining

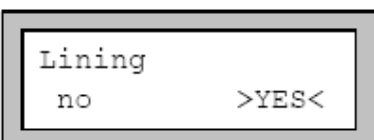

```
Lining
no      >YES<
```

If the pipe is lined, select **YES** and confirm by pressing **ENTER**.

If you select **NO**, the Portalok 7S displays the next parameter

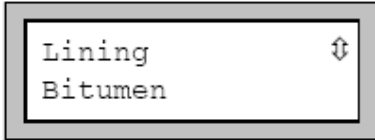

Lining  
Bitumen

Select the lining material or the entry `OTHER MATERIAL` if the lining material is not listed.

Confirm by pressing **ENTER**.

**Note:** It is possible to select which materials are to be displayed in the material selection list. Contact EESIFLO if you wish to have this when ordering.

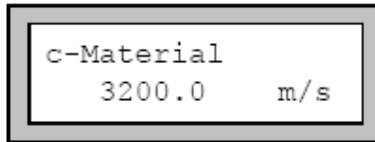

c-Material  
3200.0 m/s

If you have selected `OTHER MATERIAL`, the Portalok 7S requests the entry of the sound velocity. Enter the sound velocity for the liner material. Values between 600.0 and 6553.5 m/s are accepted.

Confirm by pressing **ENTER**.

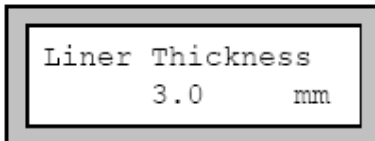

Liner Thickness  
3.0 mm

Enter the pipe liner thickness. Default value for this parameter is 3.0 mm.

Confirm by pressing **ENTER**.

**Note:** EESIFLO checks the correlation between the entered outer diameter, the pipe wall and liner thickness. The inner diameter (outer diameter - 2 x wall thickness - 2 x liner thickness) should be within the specified inner diameter range for the transducers used. An error message is displayed if this is not the case.

## Pipe Roughness

The roughness of the inner pipe wall influences the flow profile of the liquid and is used for the calculation of the profile correction factor. In most cases, the pipe roughness cannot be exactly determined, but must be estimated. For your convenience, we have compiled a list of roughness factors for a number of materials, based on experience and measurements. The display `ROUGHNESS` requests the input of a value for the selected pipe or lining material.

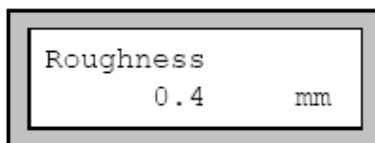

Roughness  
0.4 mm

Change the suggested value according to the condition of the inner pipe wall. Values between 0.0 mm and 5.0 mm are accepted. Default value is 0.1 mm.

Confirm by pressing **ENTER**.

## Input of the Medium's Parameters

After entering the pipe parameters, the Portalok 7S requests the medium parameters.

The medium parameters required for measurement are:

- the minimum and maximum sound velocity for the medium,
- the kinematic viscosity of the medium,
- the density of the medium (only if the output option `MASS FLOW` is activated),
- the temperature of the medium.

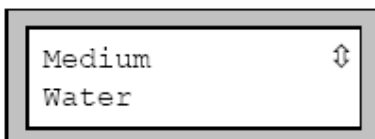

Medium  
Water

Select the medium or the entry `OTHER MEDIUM` if the medium to be measured is not listed.

Confirm by pressing **ENTER**.



If the medium has been selected, the Portalok 7S will immediately request the medium temperature. If you have selected `OTHER MEDIUM`, EESIFLO requests the entry of the minimal and maximum sound velocity, the kinematic viscosity and the density of the medium.

**Note:** It is possible to select which media are to be displayed in the medium selection list.

## Sound Velocity

EESIFLO uses the sound velocity of the medium for the calculation of the distance between the transducers at the beginning of the measurement. However, the sound velocity does not influence the measuring result directly. Often, the accurate value of the sound velocity for a given medium is unknown. A range of possible values for the sound velocity must therefore be entered.

```
c-Medium      MIN
1400.0        m/s
```

Enter the minimum and maximum values of the sound velocity for the medium you want to measure (in m/s).

Values between 800.0 m/s and 3500.0 m/s are accepted.

Confirm your entries by pressing **ENTER**.

## Kinematic Viscosity

The kinematic viscosity influences the flow profile of the liquid. The Portalok 7S uses the value of the kinematic viscosity as well as other parameters for the profile correction.

```
Kinem.Viscosity
1.00 mm2/s
```

Enter the kinematic viscosity of the medium. Values between 0.01 and 30,000.00 mm<sup>2</sup>/s are accepted.

Confirm by pressing **ENTER**.

## Density

EESIFLO now requests the density of the medium. This value is required for calculating the mass flow rate (= volume flow rate multiplied with the entered density).

**Note:** If you are not interested in measuring the mass flow rate, just confirm the displayed value by pressing **ENTER**. This will not influence your results.

```
Density
1.00 g/cm3
```

Enter the density of the medium. Values between 0.10 g/cm<sup>3</sup> and 20.00 g/cm<sup>3</sup> are accepted.

Confirm by pressing **ENTER**.

## Medium Temperature

EESIFLO requires the medium temperature for the calculation of the distance between the transducers (distance suggested at the beginning of measurement) and for correcting the sound velocity and the viscosity which both depend on temperature.

```
Medium Temperat.
20 C
```

Enter the medium temperature. The value must be within the operating range of the transducer. The default value is 20°C.

Confirm by pressing **ENTER**.

**Note:** The range of possible medium temperature depends on the operating range of the selected transducers.

## Other Parameters

### Transducer Parameters

The following display will appear at the end of parameter input:

```
TransducerType  ⬆
Standard
```

Select `STANDARD` to work with standard transducer which is part of the Portalok 7S standard offering or enter parameters or `SPECIAL VERSION` to edit the transducer parameters (manufacturer's data must be available).

Confirm by pressing **ENTER**.

**Attention!** EESIFLO cannot guarantee the precision of values obtained when working with transducers not designed for the model purchased. Measurement might be impossible.

```
Transd. Data  1
35.99
```

If you have selected `SPECIAL VERSION`, Portalok 7S will ask for the transducer data. Enter the value of the 6 transducer parameters as given by the manufacturer, confirming each entry by pressing **ENTER**.

### Cable length

```
Additional cable
65.0 m
```

Portalok 7S then asks for the length of any additional transducer cable used (not the total length of the transducer cable!). Enter the additional cable length if non standard extra lengths have been supplied and confirm by pressing **ENTER**.

You will only need to use this if you have purchased additional cable lengths

## Selection of the Sound Path Factor

```
par >MEA< opt sf
Measuring
```

In the main menu, select the program branch `MEASURING`, then press **ENTER**.

```
par >MEA< opt sf
NO DATA      !
```

If this error message appears, "no complete parameter set exists" Return to the program branch `PARAMETER` and enter the missing parameters.

EESIFLO now requests the **sound path factor**, which is the number of transits of the ultrasonic waves through the medium in the pipe.

A sound path factor of "0" (zero) is not feasible in terms of physics.

An **odd** number of transits (diagonal mode) require mounting of the transducers on opposite sides of the pipe (see illustration below).

An **even** number of transits (reflection mode) requires mounting of the transducers on the same side of the pipe (see illustration below).

Some small pipes in sound path 1 may show a negative distance. In this case, the transducers must overlap according to the negative distance.

An increased number of transit paths mean increased accuracy of the measurement. However, the increased transit distance also leads to a higher attenuation of the signal. The reflections on the opposite pipe wall and eventual deposits on the inner pipe wall cause additional amplitude losses of the sound signal. Measurements on a system where both the pipe and the medium strongly attenuate the signal may require fewer sound path transits.. The signal may be further attenuated by deposits on the inner pipe wall, resulting in a single (1) transit

Transducer installation in diagonal mode		Transducer installation in reflection mode	
number of transits	sound path	number of transits	sound path
1		2	
3		4	
etc.		etc.	

Sound path

**Note:** Positioning the transducers is easiest for even numbers (2,4,6 etc) of transit paths than for odd numbers(1,3,5 etc)  
 Tip: Select sound path 2 as this is the most convenient and quickest to get started.

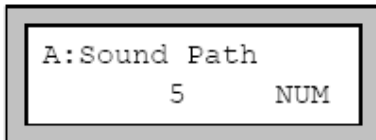

Enter the sound path factor.  
 Confirm by pressing **ENTER**.

## Mounting and Positioning the Transducers

### Distance between the Transducers

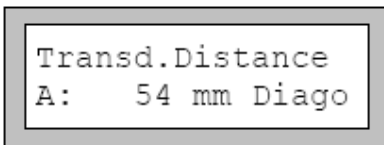

A = Measuring channel A  
 'Refle' = Reflection mode  
 'Diago' = Diagonal mode

Once the number of transit paths has been entered, the Portalok 7S indicates the mounting distance between the transducers.(here: 54 mm). The transducer distance given here is the distance between the inner edges of the transducers. For very small pipes, a negative transducer distance is possible

**Note:** The accuracy of the distance suggested by EESIFLO depends on the accuracy of both the pipe and medium parameters entered.

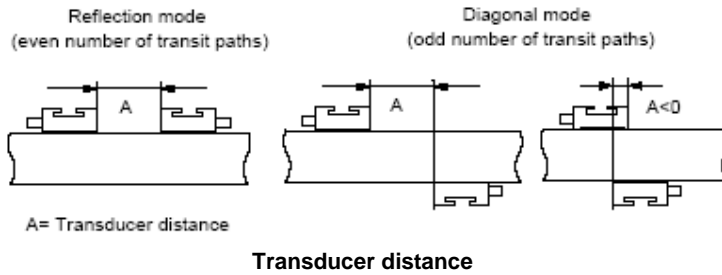

## Mounting the Transducers

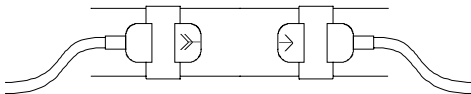

Correct positioning of the transducers

Always mount the transducers so that the front edges are opposite to each other. The engraving on the top of the transducers should form an arrow, as illustrated.

<b>Important!</b>	<p>In order to obtain maximum acoustics between the pipe and the transducers, check the following:</p> <ul style="list-style-type: none"> <li>• Rust or other deposits absorb the sound signals! Clean the pipe where you plan to mount the transducers. Remove rust or loose paint. Grind off any thick layer of paint.</li> <li>• Always apply a bead of acoustic coupling compound lengthwise down the center of the contact surface of the transducers.</li> <li>• There should be no air or air pockets between the transducer surface and pipe wall. Ensure that the mounting fixture applies sufficient pressure on the transducers.</li> </ul>
-------------------	--

## Mounting with Spring Tension Fixtures (optional)

<b>Note:</b>	Where vibration is high, we recommend the optional EESIFLO tension straps. Most applications use standard spring and chain sets which are provided. These chain sets also allow for pipe expansion or contraction.
--------------	--

<b>Note:</b>	Do not tighten the screws completely at this point!
--------------	---

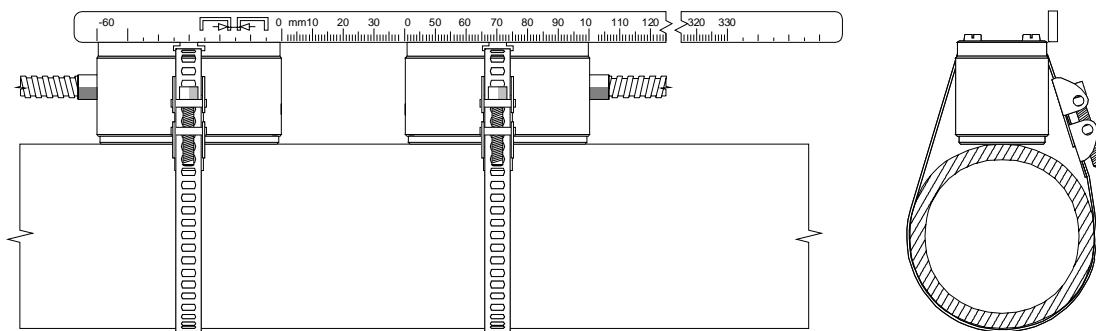

Transducers mounted with tension straps

## Mounting with Runners and Chains (Slide rail option)

- Insert the transducers in the runners. Turn the screw on top of the runners by 90° in order to engage and lock its extremity in the groove of the inserted transducer.
- Insert the ruler in the lateral slots of the runners. Adjust the transducer distance suggested by the Portalok 7s and fix the transducers with the small plastic screws on the transducer cable side of the runner.

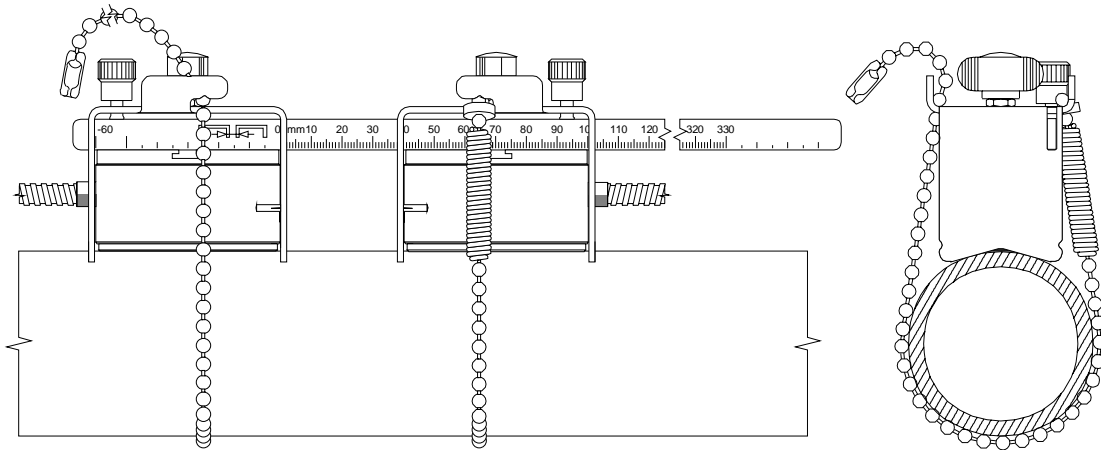

Transducers mounted with runners and chains (optional)

- Place the runners/ruler assembly on the pipe at the measuring point.
- Insert the last ball (spring end of the ball chain) in the slot on the top of one of the clips.
- Lay the chain around the pipe

**Note:** When mounting the transducers on a vertical pipe with the Portalok 7S situated lower than the pipe, it is recommended to slip the cable of the upper transducer under the tension strap in order to free it from mechanical strain.

- Pull the chain firmly against the spring tension and insert it in the second slot on the top of the runner.
- Fix the other transducer in the same way.

## Extension of the Ball Chain

To extend the chain, insert the last ball of the spring end of the extension in the fastening clip of the ball chain.

The spare fastening clips supplied with the chain can be used to repair a broken chain.

## Positioning the Transducers

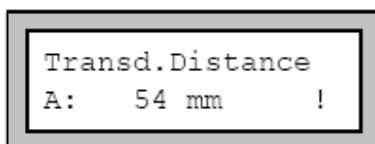

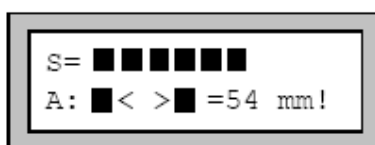

When the transducers are mounted, confirm the transducer distance by pressing **ENTER**.



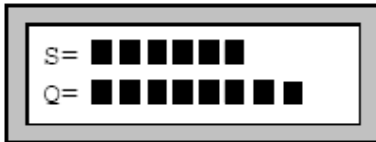

A bar graph ("S=") informs you of the amplitude of the received signal.

Adjust the transducers by moving them slightly in order to obtain a maximal length of the bar graph.

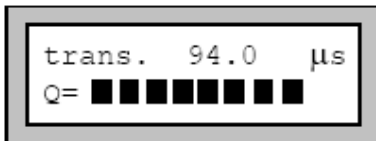

Press key  to scroll to the lower line of the display. The bar graph Displays the quality of the signal ("Q="). If the signal is not sufficient for measurement, UNDEF is displayed.



Press key  to scroll to the upper line of the display. The bar graph displays the signal amplitude ("S=") The display also indicates the transit time in microseconds.

**Note:** It is important that the maximum signal with the shortest transducer distance (shortest transit time) is achieved. However, this signal maximum should not deviate from the suggested distance by more than  $\pm 0.5$  cm (50 mm). Should deviations exceed 50mm check entered parameter inputs or repeat measurement at a different location on the pipe.

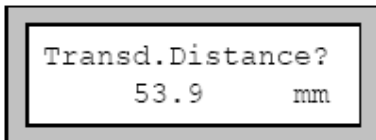

After positioning of the transducers, the suggested transducer distance is again requested with "?".

Enter the actual (precise) transducer distance and press **ENTER** or just confirm the displayed value (if within 50 mm) by pressing **ENTER**.

## Starting the Measurement

When the precise transducer distance has been entered, the measurement will be automatically activated. You may have to wait a few seconds after pressing the last enter before the unit will display the flow readings.

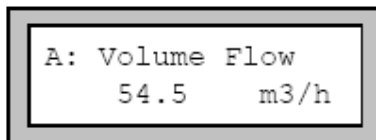

You can press **ENTER** to return to the bar graph display.

The results are displayed and transmitted according to the selected output options

## Recognition of Flow Direction

The medium flows in direction of the arrow if the display shows a positive flow reading (example: 54.5 m<sup>3</sup>/h).

The medium flows against the arrow direction if the display shows a negative flow reading (example: -54.5 m<sup>3</sup>/h).

The transducers are mounted correctly if the engraving on the two transducers together form an arrow. The transducer cables should then show in opposite directions.

The arrow, in conjunction with the displayed measured value, will help you to determine the direction of flow.

## Stopping the Measurement

You can stop the measurement at any time by pressing **B**

### Attention!

Be careful not to interrupt an ongoing measurement by inadvertently pressing **B**

## Displaying the Measured Values

The physical quantity to be measured, stored and transmitted can be set in the `OUTPUT OPTIONS`. Default display is quantity of measurement displayed on the first line and its value on the second line. It is possible to temporarily adapt the display to your requirements by selecting which quantity should be shown on the first and second line of the display.

## Selection of the Physical Quantity and of the Unit of Measurement

The Portalok 7S can measure the following quantities:

- flow velocity
- volume flow rate
- mass flow rate

The Portalok 7S measures the flow velocity directly. The volume flow is calculated by multiplying the flow velocity with the cross-sectional area of the pipe, the mass flow by multiplying the volume flow with the density of the medium.

```
par mea >OPT< sf
Output Options
```

In the main menu, select `>OPT<` `OUTPUT OPTIONS`.

```
Physic. Quant. ⇅
Volume Flow
```

Select quantity of measurement in the scroll list.

Confirm by pressing **ENTER**.

The selection of the physical quantity `SOUND VELOCITY` immediately ends the `OUTPUT OPTIONS`, since the process outputs are not active during the measurement of the sound velocity and there are thus no more settings to be made.

```
Volume in: ⇅
m3/h
```

For all quantities of measurement other than `SOUND VELOCITY`, a scroll list of the available measurement units is displayed. The previously selected unit is shown on the second line. Select the unit of measurement ie "Volume" then the physical quantity "m3/h" to be displayed and transmitted..

Confirm by pressing **ENTER**.

You can now return to the main menu by pressing **BRK**. The next displays of the program branch `OUTPUT OPTIONS` are for the activation of the output options.

# Configuration of the Display

The Portalok 7S has the option of displaying two of the measured values (one on each line of the display) the display readings may be configured according to your requirements.

You can change the displayed values independently and without interfering with the ongoing measurement. The changes have no influence on the totalizers, the storage of measured values, the operation of the process interfaces etc.

The following can be displayed on the first line of the display:

- Designation of the quantity of measurement actually being measured and recorded
- Totalizer values (if activated)
- the date and time at which the memory will be full
- the measuring mode
- the transducer distance
- the calculation function if activated
- the time remaining until the automatic stop of a programmed measurement
- the state of the alarms if any alarm outputs are activated and the display of the alarms' state is enabled.

The following information can be displayed on the second line in addition to the selected quantity of measurement:

- Flow velocity
- Mass flow rate
- Volume flow rate

Use key  to scroll through the different displays of the first line whilst measurement is on.

Use key  to scroll through the different displays of the second line while measurement is on.

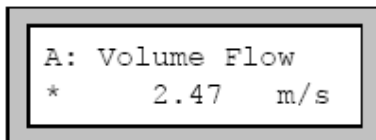

The asterisk "\*" indicates that the displayed value (here: the flow velocity) is not the selected quantity of measurement (here: the volume flow).

## Transducer Distance

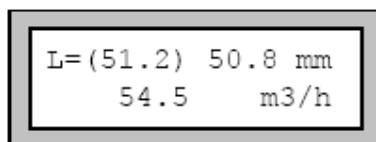

During measurement, it is possible to scroll to display the transducer distance by pressing the  key.

The actual optimum transducer distance "L" is displayed first in parenthesis (here: 51.2 mm), then the entered transducer distance (here: 50.8 mm). The optimal transducer distance might change during measurement due to temperature fluctuations for example. An eventual mispositioning of the transducers (here: -0.4 mm) will be internally compensated by the Portalok 7S.

**Attention!** Never change the transducer distance during measurement!



# Datalogging and Retrieving Data

By Scrolling through the OUTPUT OPTIONS menu, you will be prompted to save data.as well as the data storage rate The built in datalogger will normally have 60,000 values available for data storage.

To retrieve data, connect the serial cable(Null Modem) supplied with the unit to the Portalok 7S.Use the EESIDATA program (provided) to retrieve data onto your computer. Ensure that the com port settings are correct. EESIDATA will allow you to view stored values, study readings in depth and also prepare the data in graphical format for saving or printing.

## Advanced Measuring Functions

### Command Execution during Measurement

Commands that can be executed during measurement are shown on the upper line of the display. A command line always begins with a → .

Scroll on the upper line of the display with key  until the required command is displayed. Confirm your selection with **ENTER**. Depending on the instrument's settings, an authorization code might have to be entered. The commands available are the following:

#### Commands that can be executed during measurement

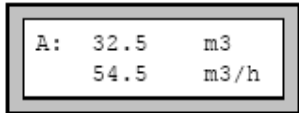
COMMAND	ACTION
→ADJUST SENSORS	 Switch to the sensor positioning mode. If a program code is activated, measuring will be automatically continued 8 seconds after the last keyboard action.
→CLEAR TOTALIZER	 All totalizer values will be reset to zero.
→BREAK MEASURE	Stop measuring and return to main menu. If a program code is activated, you have to enter the 6 digit BREAK-CODE first.

### The Damping Factor

Each measured value displayed by the instrument is actually the average of the measured values of the last x seconds, where x is the **damping factor**. A damping factor of 1 s means that the measured values are not averaged, since the measuring rate is of approx 1 value per second. The default value is 10 s. This is appropriate for normal flow conditions. Strongly fluctuating readings caused by high flow dynamics require a larger damping factor.

Select the OUTPUT OPTIONS.Scroll through the list, confirming the already selected options by pressing **ENTER**, until you reach the DAMPING option.

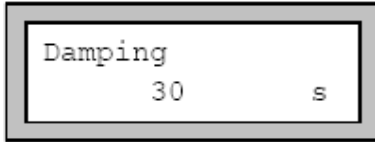

Enter the damping factor. Values between 1 s and 100 s are accepted.

Confirm by pressing **ENTER**.

Return to the main menu by pressing **BRK**.

## Flow Totalizers

The Portalok 7S totalizes the **volume** or the **mass** of medium passing through the pipe at the measuring point.

- There are two built-in flow totalizers, one for totalizing in positive flow direction, the other for totalizing in negative flow direction.
- The unit of measurement used for totalization corresponds to the volume or mass unit used in the quantity of measurement (see section ).
- Every numerical value of the totalizer consists of up to 11 characters, with a maximum of 3 figures to the right of the decimal point.

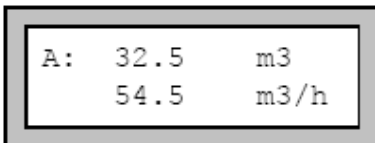

To reach the display of the totalizers, scroll on the upper display line using key .

To toggle between the display of the totalizer for positive flow direction and the totalizer for negative flow direction, press **ENTER** while a totalizer is displayed.

To reset the two flow totalizers to zero, select the command  $\rightarrow$ CLEAR TOTALIZER on the upper line of the display and confirm with **ENTER**.

**Note:** The flow velocity cannot be totalized.

## Quantity Recall

The function of the totalizer after a measurement has been stopped or after a reset can also be set in the program branch SPECIAL FUNCTION \ SYSTEM SETTINGS \ MEASURING. This setting is coldstart resistant.

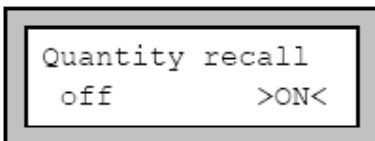

In the MEASURING scroll list, select the QUANTITY RECALL option.

If you select ON, the numerical values of the totalizers will be memorized and used for the next measurement or when the measurement is continued after a reset. If you select OFF, the totalizers will be reset to zero in both cases.

## Overflow of the Totalizers

The flow totalizers can work in two different modes:

- Without overflow: The numerical value of the respective totalizer increases up to the internal limit of  $10^{38}$ . The values are displayed as exponential numbers ( $\pm 1.00000E10$ ) if necessary. The totalizer can only be reset to zero manually.
- With overflow: The totalizer resets automatically to zero as soon as  $\pm 9999999999$  is reached.

It is always possible to reset the totalizers manually, independently of the selected option,

The totalizer wrapping mode can be set in the program branch `SPECIAL FUNCTION \ SYSTEM SETTINGS \ MEASURING`. This setting is cold start resistant.

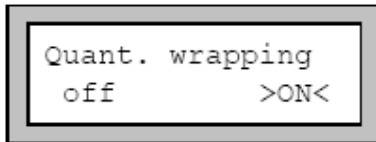

Select the `QUANT. WRAPPING` option.

Select `ON` to work with overflow, `OFF` to work without overflow.

**Note:**

- The output of sum of both totalizer (the throughput ' $\Sigma Q$ ') via a process output will not be valid after the first overflow (wrapping) of one of the respective totalizers.
- To alarm the overflow of a totalizer, activate the alarm output with the switching condition `QUANTITY` and the type `HOLD`.

## Upper Limit for Flow Velocities

A single outlier caused by heavily disturbed surroundings can appear in flow measured values. Such a measured value will, when not ignored, affect all derived quantities, which will then be unsuitable for integration (pulse outputs, e.g.).

It is possible for the instrument to ignore all measured flow velocities bigger than a preset upper limit and mark them as outlier ("invalid measured value"). This upper limit for the flow velocity can be set in the program branch `SPECIAL FUNCTION \ SYSTEM SETTINGS \ MEASURING`. This setting is cold start resistant.

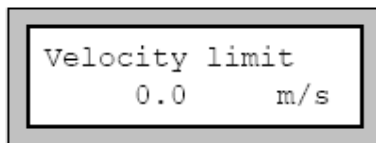

In the program branch `SPECIAL FUNCTION \ SYSTEM SETTINGS \ MEASURING`, select the `VELOCITY LIMIT` option. Enter the upper velocity limit. Values between 0.1 and **25.5 m/s** are accepted. Entering "0" switches off the test for outliers.

Confirm by pressing **ENTER**.

When the test is activated (velocity limit > 0.0 m/s), every measured flow velocity will be compared with the entered upper velocity limit. If the flow velocity is bigger than the limit:

- The flow velocity is marked as "invalid"; the measuring quantity cannot be determined..
- The display shows a '!' behind the unit of measurement. (In case of a 'normal' error, a '?' appears.)
- Tip: Set Velocity limit to 10 m/s

**Attention!**

If the defined velocity limit is too small, measurement might be impossible - most measured values are declared invalid.

## Cut-off Flow

The cut-off flow function automatically sets all measured flow velocities falling below a certain value to zero. All values derived from this flow velocity are equally set to zero. The cut-off can depend on the sign identifying the direction of flow or not. The default cut-off value is 5 cm/s. The largest cut-off value which can be set is **12.7 cm/s**.

The cut-off value can be set in the program branch `SPECIAL FUNCTION \ SYSTEM SETTINGS \ MEASURING`. This setting is cold start resistant.

```
Cut-off Flow
absolute >SIGN<
```

If you select **ABSOLUTE**, the user defined cut-off value will not depend on the sign identifying the direction of flow. There is only one limit to be set. The absolute value of the measured value will be compared with the cut-off value.

```
Cut-off Flow
factory >USER<
```

If you select **SIGN**, the user defined cut-off value will depend on the sign identifying the direction of flow. Two independent limits can be entered for positive and negative flow velocities.

If you select **FACTORY**, EESIFLO will use the factory default setting of 5 cm/s for the cut-off value.

Select **USER** to define you own cut-off.

Confirm by pressing **ENTER**.

If you have previously selected **CUT-OFF FLOW \ SIGN**, two cut-off values must be entered:

```
+Cut-off Flow
5.0 cm/s
```

Enter the cut-off flow for positive measured values. When a positive value falls below this threshold, the flow velocity is set to 0 cm/s. All derived values are equally set to zero.

```
-Cut-off Flow
-5.0 cm/s
```

Enter the cut-off flow for negative measured values. When a negative value rises above this threshold, the flow velocity is set to 0 cm/s. All derived values are equally set to zero.

If you have previously selected **CUT-OFF FLOW \ ABSOLUTE**, only one cut-off value has to be entered :

```
Cut-off Flow
5.0 cm/s
```

The limit comparison will be performed using the absolute numerical value of the measured flow velocity.

## Uncorrected Flow Velocity

For special applications, the knowledge of the uncorrected flow velocity might be of interest.

In the program branch **SPECIAL FUNCTIONS \ SYSTEM SETTINGS \ MEASURING**, you may enable or disable the flow profile correction for the flow velocity. This setting is coldstart resistant.

```
Flow Velocity
>NORMAL< uncorr.
```

In the **FLOW VELOCITY** display, select **NORMAL** to have the profile corrected flow velocity displayed and transmitted. Select **UNCORR.** to enable the display of flow velocities without flow profile correction.

Confirm by pressing **ENTER**.

```
A: PROFILE CORR.
>NO< yes
```

From now on, when the program branch **MEASURING** is selected, the Portalok will ask explicitly whether to use the profile correction or not.

```
A: FLOW VELOCITY
  2.60    m/s
```

```
A: PROFILE CORR.
no        >YES<
```

```
A: Volume Flow
*U  54.5    m/s
```

If you select **NO**, the profile correction will be completely disabled. All measuring quantities will be calculated with the uncorrected flow velocity. The designations of the measuring quantities will be displayed in capital letters to indicate this.

If you select **YES**, Portalok 7S uses the uncorrected flow velocity only if the physical quantity **FLOW VELOCITY** is selected in the **OUTPUT OPTIONS**. Portalok 7S determines all other physical quantities (volume flow, mass flow, etc.) with the corrected flow velocity. During measurement, **FLOW VELOCITY** will be displayed in capital letters, indicating that the displayed flow velocity is uncorrected.

Confirm by pressing **ENTER**.

However, in both cases, the corrected flow velocity can still be displayed by scrolling on the second line of the display (key ). The uncorrected flow velocity is preceded by "U".

## Limit Values for the Transducer Parameters

It is possible to modify the value of the minimal pipe inner diameter accepted by the Portalok 7S for a certain type of transducer. This setting is cold-start resistant.

```
DNmin Q-Sensor
  25    mm
```

Enter HotCode **071001**.

Enter the minimal pipe inner diameter the Portalok 7S should accept. Confirm each value by pressing **ENTER**.

## Protection against Interruption

The special function **SET PROGRAM CODE** allows the user to input a 'secret number' that must be entered to interrupt an ongoing measurement, as a protection against unwanted interruption. When a program code has been entered, the full code (= **BREAK** code) must be entered to interrupt the measure. To execute commands during a running measure, you only need to enter the first 3 digits of the code (= **ACCESS** code).

When a program code has been set, the message "**PROGRAM CODE IS ACTIVE**" might be displayed when a key is pressed. The message will disappear after a few seconds.

**Note!** Don't forget the program code!

```
Special Funct. ⬆
Set program code
```

In the **SPECIAL FUNCTION** program branch, select the **SET PROGRAM CODE** option.

```
Program Code
-----
```

Enter a program code of up to 6 characters.

Confirm the entered code by pressing **ENTER**.

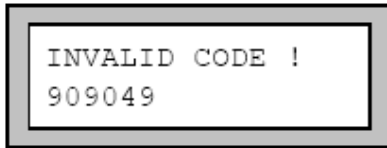



This error message warns you if you have entered a reserved number

The previous program code, as far as existing, is valid until you enter another code correctly or deactivate the program code.

## Interruption of Measurement

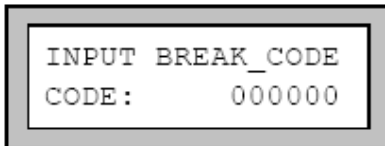
When a program code has been set, the meter will request it when you select a command line or press key **BRK** during measurement.



Enter the program code (ACCESS or BREAK code depending on what you want to do) using keys  and .

With key **C**, you can cancel the code input and return to the measure.

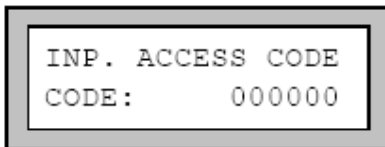

The program code "000000" is always displayed first in the program code input display. If you enter a program code beginning with "000", you will have a nearly immediate access to measure related commands.

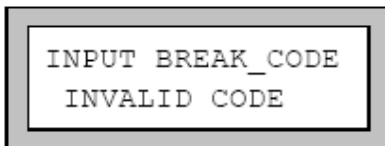

If the entered code is **not** the current program code, an error message is displayed for a few seconds. If the entered code is valid, the command will be executed or the measurement will be interrupted.

## Deactivating a Program Code

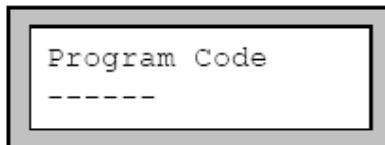

A program code can be cancelled by entering "-----" in the PROGRAM CODE display (SPECIAL FUNCTION \ SET PROGRAM CODE). Confirm with **ENTER**.

If you enter "-" less than six times, the Portalok 7S reads your entry as a new program code!

# Libraries

The internal data bank of the instrument contains the properties of more than 20 different materials (pipe material, lining) and more than 40 different media. It is possible to select the materials and fluids displayed in the selection lists of the program branch `PARAMETER` (pipe material, lining, and medium). You can thus adapt the list to your specific measuring tasks and the shorter selection lists make your work more efficient.

An integrated coefficient storage (user area), allows you to define new materials and media. If necessary, the properties of these new materials and media can be defined as temperature-dependent or pressure-dependent polynomials. The coefficient storage can be partitioned as you like.

## Editing the Selection Lists

The procedures for the edition of the material and of the media selection list are the same. We describe here the edition of the material selection list.

**Note:** User materials and media are always displayed in the selection lists of the program branch `PARAMETER`.

```
Special Funct.  ⇅  
SYSTEM settings
```

In the program branch `SPECIAL FUNCTION`, select the option `SYSTEM SETTINGS` and press **ENTER**.

```
SYSTEM settings ⇅  
Libraries
```

In the `SYSTEM SETTINGS` scroll list, select the option `LIBRARIES` and press **ENTER**.

```
Libraries  ⇅  
Material list
```

Select `MATERIAL LIST` to edit the material selection list or `MEDIUM LIST` to edit the medium selection list.

Select `GO BACK` to return to the `SYSTEM SETTINGS`.

Confirm your selection by pressing **ENTER**.

```
Material list  
factory >USER<
```

Select `FACTORY` if all materials/media of the internal data bank should appear in the selection lists. An already existing selection list will not be deleted but only deactivated.

Select `USER` to activate the user-defined selection list.

Confirm by pressing **ENTER**.

```
Material list  ⇅  
>Show list
```

If `USER` has been selected, you can edit the selection list. The options of the scroll list are described later

```
Material list  ⇅  
>End of Edit
```

After edition, select `END OF EDIT` and press **ENTER**.

```
Save list      ?  
no             >YES<
```

Select **YES** to save all changes made in the selection list or **NO** to leave the edit menu without saving.

Confirm by pressing **ENTER**.

**Note:** If you quit the edit menu with **BRK** before saving, all changes will be lost.

## Displaying a Selection List

```
Material list  ⬆  
>Show list
```

Select **SHOW LIST** and press **ENTER** to display the selection list as it would appear in the program branch **PARAMETER**.

```
Current list=  ⬆  
>Carbon Steel
```

The current selection list is displayed as a scroll list on the second line of the screen. User materials/media are always part of the current user-defined selection list.

```
Current list=  ⬆  
>Other Material
```

Press **ENTER** to exit the current selection list and return to the selection list edit menu.

## Adding a Material/Medium to the Current List

```
Material list  ⬆  
>Add Material
```

To add a material/medium to the current selection list, select **ADD MATERIAL** or **ADD MEDIUM**.

Confirm by pressing **ENTER**.

```
>Add Material  ⬆  
Rubber
```

The Portalok 7S displays as a scroll list on the second line all materials/media which are not in the current selection list.

Select the material/medium to be added and press **ENTER**. The material/medium is added to the selection list.

**Note:** The materials/media will appear in the list in the order in which they have been added.

## Deleting a Material/Medium from the Current List

```
Material list  ⬆  
>Remove Material
```

To remove a material or a medium from the selection list, select **REMOVE MATERIAL** or **REMOVE MEDIUM**.



```
>Remove Materia ⇅  
Rubber
```

Portalok 7S displays as a scroll list on the second line all materials/media of the current selection list.

Select the material/medium to be removed and press **ENTER**. The material/medium is deleted from the selection list.

**Note:** User materials/media are always part of the current user-defined selection list. They cannot be deleted.

## Deleting all Materials/Media from the Current List

```
Material list ⇅  
>Remove all
```

Select **REMOVE ALL** and press **ENTER** to remove all materials/media from the current selection list. User-defined materials and media will not be removed.

**Note:** User materials/media are always part of the current user-defined selection list. They cannot be deleted.

## Adding all Materials/Media to the Current List

```
Material list ⇅  
>Add all
```

Select **ADD ALL** and press **ENTER** to add all materials/media of the internal data bank to the current selection list.

## Defining New Materials and Media

It is possible to add self-defined materials or media ("user materials" or "user media") to the internal data bank. These entries are stored in the coefficient storage ("user area").

The number of user materials/media that can be defined depends on the partitioning of the user area. The user materials/media will appear in the selection lists of the program branch **PARAMETER**. The storage of user defined materials and media is cold-start resistant and remains active even if the unit has been switched off.

The basic properties of a medium are its maximum and minimum sound velocities, its viscosity and its density. The basic properties of a material are its transversal and longitudinal sound velocities and its typical roughness. If the Extended Library function is activated, you can additionally define temperature or pressure dependent properties for materials or media.

**Note:** The user area must be partitioned before any data can be stored.

## Partitioning the User Area

The capacity of the user area can be partitioned in the following data set types:

- Basic data of a material (sound velocity, typical roughness)
- Basic data of a medium (sound velocities, kinematic viscosity, density)

### Capacity of the user area

	Maximum number of data sets	Corresponding occupancy of the user area in %
Materials	13	97
Media	13	95

```
Libraries      ↕
Format USER-AREA
```

In the SPECIAL FUNCTIONS \ SYSTEM SETTINGS \ LIBRARIES program branch, select the entry FORMAT USER-AREA.

Confirm by pressing **ENTER**.

```
MAXIMAL : 13 !
Materials: 15
```

A message will be displayed if the selected number of data sets exceeds the memory of the user area.

```
Format USER-AREA
Materials:  03
```

Enter the required number of user materials.

Confirm by pressing **ENTER**.

```
Format USER-AREA
Media:      03
```

Enter the required number of user media.

Confirm by pressing **ENTER**.

```
Format USER-AREA
Heat-Coeffs: 00
```

Enter 0. Heat flow coefficients can only be defined when your instrument is equipped with temperature inputs. (not available with Portalok 7S)

Confirm by pressing **ENTER**.

```
Format USER-AREA
Steam-Coeffs: 00
```

Enter 0. Steam coefficients can only be defined when your instrument is equipped with temperature inputs.

(not available with Portalok 7S)

Confirm by pressing **ENTER**.

```
Format USER-AREA
Concentrat.: 00
```

Enter 0. Concentration coefficients can only be defined when your instrument is equipped with temperature inputs. (not available in the Portalok 7S series)

Confirm by pressing **ENTER**.

```
USER-AREA:
      52% used
```

EESIFLO displays the memory of the user area for the selected partition for a few seconds

```

Format NOW?
no          >YES<
  
```

EESIFLO requests confirmation of the selected partition. Select YES to proceed to partitioning.

Confirm by pressing **ENTER**.

```

FORMATTING...
■■■■■■■■...
  
```

The Portalok 7S formats the user area according to your inputs. This procedure takes a few seconds.

```

Libraries  ↕
Format USER-AREA
  
```

Once the formatting is finished, the Portalok 7S will return to the `FORMAT USER-AREA` display.

### Keeping Data during Formatting of the User Area

When reformatting the user area, EESIFLO can keep up to 8 data sets of each type.

*Example 1: Reducing the number of user materials from 5 to 3. The data sets #01 to #03 are kept. The last two data sets #04 and #05 are deleted.*

*Example 2: Increasing the number of user materials from 5 to 6. All 5 data sets are kept.*

## Extended Library Function

The Extended Library function allows you to enter temperature or pressure dependent properties. The function has to be activated in the `SPECIAL FUNCTIONS` program branch before defining a material or medium with such properties.

Table1 gives an overview of the properties that can be entered and what they are needed for.

**Table 1: Medium and material properties that can be stored**

Property	Property is necessary for...
Basic data of a medium	
sound velocity (MIN and MAX)	start of measurement
viscosity	profile correction of the flow velocity
density	mass flow rate calculation
Basic data of a material	
transversal sound velocity	flow measurement
longitudinal sound velocity	wall thickness measurement and/or flow measurement
type of sound wave to be used	flow measurement
typical roughness	profile correction of the flow velocity

**Enter only those properties which are relevant for your measuring task.**

*Example: The density of a medium is unknown. If the mass flow rate is not required, you may set the density to any constant value. The measurement of flow velocity and volume flow is not affected by this. However, the value of the mass flow rate will be incorrect.*

The dependency of certain properties on process quantities (temperature, pressure) can be described by polynomials of grade 0 to 4 or by other specialized interpolation functions. In most cases constant values or a linear dependency are quite sufficient. For instance, if the temperature fluctuations at the measuring point are small compared with the temperature dependencies of the properties, considering a linear dependency or completely neglecting the temperature dependency will not result in a considerable additional measuring error. If the process conditions fluctuate strongly and the properties of the involved materials/media have a pronounced temperature dependency (the viscosity of hydraulic oils for example), polynomials or other specialized functions should be used for the interpolation.

If in doubt, consult EESIFLO to find the best solution for your specific measuring task.

## Specialized Interpolations

Some dependencies are approximated in an unsatisfactory way by polynomials. EESIFLO offers some specialized interpolation functions (option "Basics:Y=f(x,z)"). Multidimensional dependencies ( $y=f(T,p)$ ) can also be approximated with these specialized functions.

Contact EESIFLO for further information about specialized interpolations.

```
Libraries      ↕  
Extended Library
```

In the SPECIAL FUNCTIONS \ SYSTEM SETTINGS \ LIBRARIES program branch, select the entry EXTENDED LIBRARY.

Confirm by pressing **ENTER**.

```
Extended Library  
off           >ON<
```

Select **OFF** to disable the Extended Library function. You can then enter basic material and media properties only as constants. The installation of a user medium/material will require only a few keystrokes.

Select **ON** if you wish to enter additional properties of the media/materials or temperature or pressure dependent properties.

Confirm by pressing **ENTER**.

## Input of Material/Media Properties without the Extended Library Function

If you do not wish to define temperature or pressure dependent material or medium, the extended library function should be disabled. The procedures for the input of material and medium properties are the same.

```
Special Funct. ↕  
Install Material
```

In the program branch SPECIAL FUNCTION select **INSTALL MATERIAL** or **INSTALL MEDIUM** and press **ENTER**.

```
USER Material  
NOT FORMATTED !
```

An error message appears if no data or *user media* sets for user materials were reserved when formatting the user area. In this case, partition the user area according to your requirements.

```
Install Material  
>EDIT<  delete
```

Select **EDIT** and press **ENTER**.

```
USER MATERIAL ↕  
#01:--not used--
```

Select one of the available memory locations.

Confirm by pressing **ENTER**.

```
EDIT TEXT (↑↓←→)
USER MATERIAL 1
```

Default name for a user material or medium is "USER MATERIAL N" or "USER MEDIUM N", with N an entire number. This designation can be modified now.

**Note:** There are 95 ASCII-characters (letters, capital letters, numbers, special characters [! ? " + - ( ) > < % \* ~ etc.] available for the designation of your material/medium, with a maximum of 16 characters per designation. The input of text is described in section .

```
EDIT TEXT (↑↓←→)
Polystyrene
```

Press **ENTER** when the edition of the designation is finished.

#### FOR A MATERIAL:

```
c-Material
1590.0 m/s
```

The Portalok 7S requests the sound velocity of the material. Table B . of Appendix B gives the sound velocities of some materials. Values between 600.0 and 6553.5 m/s are accepted.

Confirm by pressing **ENTER**.

```
Roughness
0.4 mm
```

Enter the roughness of the pipe, taking into consideration the state of the pipe. Table B . of Appendix B gives typical roughness values of pipes.

Confirm by pressing **ENTER**.

#### FOR A MEDIA:

```
c-Medium MIN
1400.0 m/s
```

Enter the minimum value of the sound velocity (in m/s) for the medium you want to measure. Values between 800.0 and 3500 m/s are accepted.

Confirm by pressing **ENTER**.

```
c-Medium MAX
1550.0 m/s
```

Enter the maximum value of the sound velocity (in m/s) for the medium you want to measure. Values between 800 and 3500 m/s are accepted.

Confirm by pressing **ENTER**.

```
Kinem.Viscosity
1.01 mm2/s
```

Enter the kinematic viscosity of the medium. Values between 0.01 and 30,000.00 mm<sup>2</sup>/s are accepted.

Confirm by pressing **ENTER**.

```
Density
1.00 g/cm3
```

Enter the density of the medium.

Confirm by pressing **ENTER**.

## Input of Material Properties with the Extended Library Function

Ensure the Extended Library function is activated.

```
Special Funct. ⬆
Install Material
```

In the program branch `SPECIAL FUNCTIONS`, select `INSTALL MATERIAL` and press **ENTER**.

```
USER Material
NOT FORMATTED !
```

An error message appears if you did not reserve data sets for user materials when formatting the user area. In this case, partition the user area according to your requirements.

```
Edit Material ⬆
Basics:Y=const.
```

Select the required dependence of the properties on the temperature or pressure.

Select "Y=const." to enter the properties as constants.

```
Basics:Y=m*X +n
Basics:Y=Polynom
Basics:Y=f(x,z)
...go back
```

Select "Y=m\*X +n" to enter the properties as linear functions of the temperature.

Select "Y=Polynom" to enter the properties as polynomials  $y = k_0 + k_1 \cdot x + k_2 \cdot x^2 + k_3 \cdot x^3 + k_4 \cdot x^4$ .

Select "Y=f(x,z)" to enter the properties as one of the pre-defined functions (for experienced users or by arrangement with EESIFLO).

Select `GO BACK` to return to the previous menu.

```
USER MATERIAL ⬆
#02:--not used--
```

Select the material properties to be defined. Default name for a user material or medium is "USER MATERIAL N" or "USER MEDIUM N", with N an entire number.

```
USER MATERIAL 2
>EDIT< delete
```

If you have selected a material which properties are already defined, the Portalok 7S requests confirmation. Select `EDIT` to edit the properties of the material, `DELETE` to delete the already defined properties and return to the `EDIT MATERIAL` scroll list.

```
#2:Input Name:
USER MATERIAL 2
```

Enter the material designation. Press **ENTER** to confirm when finished.

You will now be requested to enter the transversal and longitudinal sound velocity of the material in m/s. Depending on the selected dependence of the material properties on the process quantities, you will have to enter one to five coefficients for each material property. Confirm each value with **ENTER**. If you are editing an already defined material, the Portalok 7S will request each property to be edited. Select `YES` or `NO` and confirm by pressing **ENTER**, then edit the coefficients.

```
Default soundsp.
long. >TRANS.<
```

Select the kind of sound wave to be used for the flow measurement. The transversal sound wave (`TRANS`) is normally used.

Confirm by pressing **ENTER**.

```
Roughness
      0.4   mm
```

Enter the typical roughness of the material.

Confirm by pressing **ENTER**.

```
Save changes
no          >YES<
```

Select **YES** to save the entered properties, **NO** to leave without saving.

Confirm by pressing **ENTER**.

## Input of Medium Properties with the Extended Library Function

Ensure the Extended Library function is activated

```
Special Funct.  ⬆
Install Medium
```

In the program branch **SPECIAL FUNCTIONS**, select **INSTALL MEDIUM** and press **ENTER**.

```
USER Medium
NOT FORMATTED !
```

An error message appears if you did not reserve data sets for user media when formatting the user area. In this case, partition the user area according to your needs

```
Edit Medium  ⬆
Basics:Y=const.
```

Select the required dependence of the properties on the temperature or pressure.

Select "Y=const." to enter the properties as constants.

```
Basics:Y=m*X +n
Basics:Y=Polynom
Basics:Y=f(x,z)
...go back
```

Select "Y=m\*X+n" to enter the properties as linear functions.

Select "Y=Polynom" to enter the properties as polynomials  $y = k_0 + k_1 \cdot x + k_2 \cdot x^2 + k_3 \cdot x^3 + k_4 \cdot x^4$ .

Select "Y=f(x,z)" to enter the properties as one of the pre-defined functions (for experienced users or by arrangement with EESIFLO).

Select **GO BACK** to return to the previous menu.

```
USER MEDIUM  ⬆
#01:--not used--
```

Select the medium which properties to be defined. Default name for a user material or medium is "USER MATERIAL N" or "USER MEDIUM N", with N an entire number.

```
USER MEDIUM  1
>EDIT<      delete
```

If you have selected a medium which properties have already been defined, the Portalok requests confirmation. Select **EDIT** to edit the properties of the medium, **DELETE** to delete the already defined properties and return to the **EDIT MEDIUM** scroll list.

```
#1:Input Name:
USER MEDIUM 1
```

Enter the medium designation. Press **ENTER** to confirm when finished.

You will now be requested to enter the longitudinal sound velocity (in m/s), the kinematic viscosity (in  $\text{mm}^2/\text{s}$ ) and the density (in  $\text{g}/\text{mm}^3$ ) of the medium. Depending on the selected dependence of the medium properties on the process quantities, you will have to enter one to five coefficients for each medium property. Confirm each value by pressing **ENTER**. If you are editing an already defined medium, EESIFLO will ask you for each property if it should be edited. Select **YES** or **NO** and confirm by pressing **ENTER**, then edit the coefficients.

```
Save changes
no >YES<
```

Select **YES** to save the entered properties, **NO** to leave without saving.

Confirm by pressing **ENTER**.

## Deleting a User Material or User Medium

To delete a user material or medium, proceed as follows:

```
Install Material
edit >DELETE<
```

In the program branch **SPECIAL FUNCTION**, select **INSTALL MATERIAL** or **INSTALL MEDIUM** and press **ENTER**.

Select **DELETE** and confirm by pressing **ENTER**.

```
USER MATERIAL ⬆
#01:Polystyrene
```

Select the user material or medium to be deleted.

Confirm by pressing **ENTER**.

```
Really Delete?
no >YES<
```

The Portalok 7S requests confirmation. Select **YES** or **NO**.

Confirm your selection by pressing **ENTER**.



# Settings

## Setting the Internal Clock

The Portalok 7S features a battery buffered clock. During measurement, the data is automatically stamped with date and time.

### Setting the Time

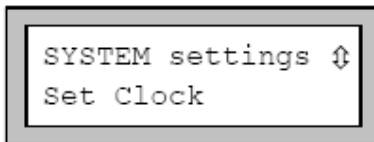

In the program branch SPECIAL FUNCTION, select the SYSTEM SETTINGS option.

Confirm by pressing **ENTER**.

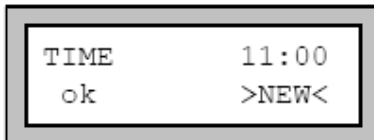

The actual time is displayed. Select **OK** to confirm or **NEW** to set the time.

Confirm by pressing **ENTER**.

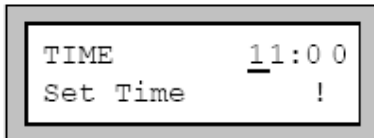

Use key  to select the digit to be edited. See section for more information on the numeric input mode.

Use keys  and  to edit the selected digit.

Confirm your setting by pressing **ENTER**.

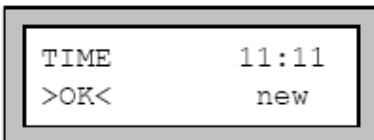

The next display shows the newly set time. Select **OK** to confirm or **NEW** to set the time again.

Confirm by pressing **ENTER**.

### Setting the Date

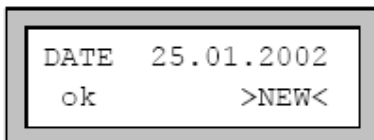

Once the time has been set, the DATE display will appear. Select **OK** to confirm or **NEW** to set the date.

Confirm by pressing **ENTER**.

Please note date is Day/Month/Year

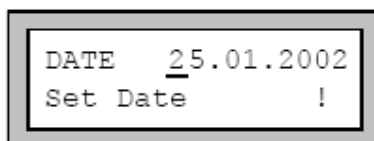

Use key  to select the digit to be edited. See section for more information on the numeric input mode.

Use keys  and  to edit the selected digit.

Confirm your setting by pressing **ENTER**.

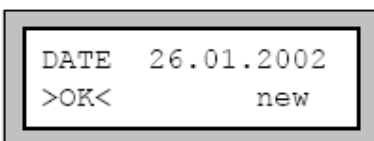

The next display shows the newly set date and requests confirmation. Select **OK** to confirm or **NEW** to set the date again.

Confirm by pressing **ENTER**.

## Settings for the Dialogues and Menus

```
SYSTEM settings ↕  
Dialogs/Menus
```

In the program branch `SPECIAL FUNCTION`, select the `SYSTEM SETTINGS`, then the `DIALOGS/MENUS` option.

**Note:** The Portalok 7S stores the `DIALOG/MENUS` settings at the end of the dialogue. If you exit the program branch before the end of the dialogue, your settings will not be stored.

## Input of the Pipe Circumference

```
Pipe circumfer.  
off >ON<
```

`ON` enables you to enter the pipe circumference instead of the pipe diameter in the program branch `PARAMETER`.

This setting is cold-start resistant.

Confirm by pressing **ENTER**.

```
Outer Diameter  
100.0 mm
```

When the `PIPE CIRCUMFERENCE` option is `ON`, Portalok 7S will still request the outer diameter in the program branch `PARAMETER`. However, you can switch to the `CIRCUMFERENCE` display by entering 0 (zero) and pressing **ENTER**.

```
Pipe Circumfer.  
314.2 mm
```

The value displayed in the `CIRCUMFERENCE` display is calculated using the last displayed value of the outer diameter.

(For example:  $100 \text{ mm} \times \pi = 314.2 \text{ mm}$ )

```
Pipe Circumfer.  
180 mm
```

You can now enter the circumference of the pipe.

(The parameter limits for the circumference are calculated using the limits for the outer diameter.)

```
Outer Diameter  
57.3 mm
```

The program branch `PARAMETER` displays the outer diameter corresponding to the entered circumference.

(For example:  $180 \text{ mm} : 3.142 = 57.3 \text{ mm}$ )

**Note:** The edition of the circumference is of a temporary nature. When the unit switches back to the display of the pipe circumference (internal re-calculation), slight rounding errors may occur.  
Example: Entered circumference = 100 mm, displayed outer diameter = 31.8 mm. When the unit switches back to the circumference internally, a value of 99.9 mm will be displayed.

## Input of the Fluid Pressure

The Portalok 7S calculates the dependency of fluid properties on pressure.

```
Fluid pressure
off          >ON<
```

In the FLUID PRESSURE display, select ON if you wish to activate the fluid pressure query in the program branch PARAMETER. The fluid pressure must be between 1 and 600 bar.

If you select OFF, the Portalok 7S uses a fluid pressure of 1.0 bar in all calculations.

## Input mode for the Measuring Point Designation

```
Meas.Point No.:
-          ( ↑↓←→ )
```

Select "1234" if you wish to identify the measuring points using only numbers, point and dash.

Select "↑↓←→" if you wish to enter the measuring point designations using the ASCII-editor (see section).

## Display of the Last Entered Transducer Distance

```
Transd. Distance
auto          >USER<
```

If you select TRANSDUCER DISTANCE \ USER, Portalok 7S will display the last precise transducer distance entered after positioning of the transducers.

```
Transd.Distance?
(50.8) 50.0 mm
```

If the suggested transducer distance and the entered distance are not identical, the suggested value is then displayed in parenthesis on the left, followed by the last precise transducer distance entered. **This setting is recommended if you always measure at the same measuring point.**

```
Transd.Distance?
50.8 mm
```

If you select TRANSDUCER DISTANCE \ AUTO, EESIFLO will only display the suggested transducer distance after the positioning of the transducers. **This setting is recommended if the measuring point changes often.**

## Error-Value Delay

```
Error-val. delay
damping >EDIT<
```

EDIT enables you to enter an error-value delay. The error-value delay is the time after which a special error value will be sent to an output when no valid measured values are available. If you select DAMPING, Portalok 7S uses the value of the damping as error-value delay.

## Display of the Alarms' State

```
SHOW RELAIS STAT
off          >ON<
```

ON activates the display of the alarms' state during measurement.

**Note:** EESIFLO stores all changes at the end of this configuration dialogue.

## Measurement Settings

```
SYSTEM settings ↕  
Measuring
```

In the program branch `SPECIAL FUNCTION`, select the `SYSTEM SETTINGS`, then the `MEASURING` option.

**Note:** Portalok 7S stores the `MEASURING` settings at the end of the dialogue. If you exit the program branch before the end of the dialogue, your settings will not be stored.

```
SKYDROL Korrekt  
>OFF<      on
```

Select `OFF` and confirm by pressing **ENTER**.

```
Flow Velocity  
>NORMAL< uncorr.
```

Select `NORMAL` to always have the profile corrected flow values displayed and output, `UNCORR.` to obtain flow values without flow profile correction for output and data storage. This setting is cold-start resistant..

Confirm by pressing **ENTER**.

```
Cut-off Flow  
>ABSOLUTE< sign
```

**ENTER** a lower limit for the flow velocity..

```
Cut-off Flow  
factory >USER<
```

```
Velocity limit  
24.0      m/s
```

**ENTER** an upper limit for the flow velocity. Values between 0.1 and 25.5 m/s are accepted. Entering "0" switches off the flow velocity control.

```
Quant. wrapping  
off      >ON<
```

Select the overflow option of the totalizers.

```
Quantity recall  
off      >ON<
```

In the `QUANTITY RECALL` display, select `ON` to keep the previous numerical values of the totalizers after restart of the measurement. Select `OFF` to reset totalizers to zero after restart of the measurement.

**Note:** Portalok 7S stores all changes of the `SYSTEM SETTINGS` at the end of this dialogue.

## Setting the Contrast

```
SYSTEM settings ⬆  
Miscellaneous
```

In SPECIAL FUNCTION \ SYSTEM SETTINGS, select MISCELLANEOUS and press **ENTER**.

```
SETUP DISPLAY  
< CONTRAST >
```

Set the contrast of the display using the following keys:  
to increase contrast or decrease use the right and left arrow keys

**Note:** The contrast will be reset to "medium" after a coldstart.

## Instrument Information

```
Special Funct. ⬆  
Instrum. Inform.
```

Select SPECIAL FUNCTION \ INSTRUM. INFORM. to obtain information about the flowmeter:

- the type designation and the serial number of your instrument and
- the version of the firmware.

Confirm with **ENTER**.

```
EESXXXX-00000999  
v 5.xx 11.11.00
```

The type designation and the serial number of your instrument are displayed on the first line.

The firmware version and its date are displayed on the second line for example. Here: Version V5.xx from 11/11/2000

Confirm with **ENTER**.

# SuperUser Mode

The SuperUser mode is used for experimental work.

Features of the SuperUser mode:

- The flowmeter operates without observing pre-set standard parameters.
- There are no plausibility checks when parameters are being entered.
- The Portalok 7S does not operate outside the physical laws and specifications.
- The cut-off flow velocity is not active.
- The sound path factor must always be entered numerically.

It is possible to modify the value of the minimal pipe inner diameter accepted by EESIFLO for a certain type of transducer without entering the SuperUser mode..

## Activating/Deactivating

Enter the **HotCode 071049** to activate the SuperUser mode.

```
SUPERUSER MODE
*IS ACTIVE NOW *
```

EESIFLO indicates that the SuperUser mode is activated.

Confirm by pressing **ENTER**. The main menu will appear again.

Enter the HotCode **071049** again to deactivate the SuperUser mode.

```
SUPERUSER MODE
IS PASSIVE NOW
```

EESIFLO then indicates that the SuperUser mode is deactivated.

Confirm by pressing **ENTER**. The main menu will appear again.

You can also deactivate the SuperUser mode by switching EESIFLO off.

## Transducer Parameters

In SuperUser mode, the `TRANSDUCER TYPE` display will appear at the end of parameter input even though the transducers were detected and recognized by the instrument.

```
Transducer Type ↕
Q2E-314
```

Confirm the displayed transducer type (here for example: Q2E-314) or select a transducer type in the scroll list. If you wish to edit the transducer parameters, select the option `SPECIAL VERSION`.

Confirm by pressing **ENTER**.

```
Transd. Data 1
35.99
```

If you have selected `SPECIAL VERSION`, the Portalok 7S will request the transducer data. Enter the value of the 6 transducer parameters as given on the transducer data card, confirming each entry with **ENTER**.

## Malfunctions in SuperUser Mode

Since the SuperUser mode operates without any plausibility checks, nonsensical entries may result in an automatic switching-off of the instrument or in a crash of the internal software. This would occur, for example, if you enter 0 (zero) as the number of sound paths or if you specify an outer diameter of 0.1 mm.

In such a case, switch the flowmeter ON again and reactivate the SuperUser mode.

If necessary, RESET the instrument by pressing keys **BRK**, **C** and **ENTER** simultaneously.

**Note:**

Switching OFF and resetting both deactivate the SuperUser mode.

# Measuring the Sound Velocity of the Medium

```
par mea >OPT< sf
Output Options
```

In the main menu, select the program branch **OUTPUT OPTIONS**.

```
Physic. Quant. ⬆
Sound velocity
```

Select the sound velocity as quantity of measurement.  
Confirm by pressing **ENTER**.

This selection immediately ends the program branch **OUTPUT OPTIONS** since the sound velocity measurement is not transmitted to the outputs.

To start the measurement, select the program branch **MEASURING**.

```
A:c-Medium ca. ?
      1475   m/s
```

Enter an estimated value for the sound velocity of the medium. Values between 800 and 3500 m/s are accepted.

Confirm by pressing **ENTER**.

```
A:Reflection Mod
no           >YES<
```

Select **YES** to measure in reflection mode, **NO** to measure in diagonal mode. Generally, the correct positioning of the transducers in reflection mode is easier than in diagonal mode.

```
A:Transd. Distan
24.7 mm Reflecti
```

Mount the transducers on the pipe, according to the suggested transducer distance. Confirm by pressing **ENTER**.

(EESIFLO calculates the suggested transducer distance on the base of the estimated value of the sound velocity and the actual parameters.)

```
MOVE TRANSDUCER!
■■■■■■■■
```

The amplitude of the received signal is displayed as a bar graph. Move one of the transducers until the bar graph indicates the best signal. One should try to obtain the maximal signal amplitude with the shortest transducer distance possible.

Press **ENTER** to conclude the positioning of the transducers.

**Attention!** Do not move the transducers any more!

```
Transd.Distance?
      25.5   mm
```

Measure and enter the current (precise) transducer distance.

(In this example, 25.5 mm is the current precise transducer distance.)

Confirm by pressing **ENTER**.



The following error messages might appear at this point:

```
ESTIMATED VALUE
TOO LARGE      !
```

```
ESTIMATED VALUE
TOO SMALL      !
```

In both cases, the entered estimated value for the sound velocity differs too much from the real sound velocity of the medium. The transducers were positioned to a parasitic signal or an echo.

Confirm error messages by pressing **ENTER**. Enter a new estimate for the sound velocity.

```
Sound velocity
c= 1488.1 m/s
```

As soon as you have entered an estimated value compatible with the real sound velocity of the medium, the measurement starts.

## Displayed Information

Press keys  and  to obtain further information in the upper or lower line of the display.

```
Curr.Trans.Dist.
L= 25.5 mm
```



### Current transducer distance (L):

Distance entered during the last positioning of the transducers. The sound velocity is calculated using this value.

```
Better distance
(L*= 25.2) mm
```



### Better distance (L\*):

Transducer distance derived from the measured sound velocity.

This allows you to detect wrong positioning. Still, do not change the transducer distance at this point!

```
t= 94.51 μs
c= 1488.1 m/s
```



### Signal transit time (t):

The signal transit time in the medium can be displayed on the upper line.

Conclude the ongoing measurement by pressing **ENTER**.

The positioning of the transducers can be repeated now.

```
Search again ?
no >YES<
```

The Portalok 7S asks you if you want to search again for the correct transducer distance.

Select **NO** if the sound velocity of the medium has been measured precisely ( $|L^*-L| < 1$  mm).

Select **YES** if the difference between the actual transducer distance and the better distance is of 1 mm or more, or if no signal could be found. A new measurement cycle will be started.

The cycle can be repeated as often as necessary. In most cases, one or two cycles are quite enough for measuring the sound velocity.

```
Store data      ?  
no             >YES<
```

Select **YES** to store the measured sound velocity in the actual parameter record for flow measurement.

```
c-Medium is:  
1488.1 m/s
```

The measured sound velocity can be edited before it is stored.

Confirm by pressing **ENTER**.

The name of the medium of the actual parameter record is changed to **OTHER MEDIUM**.

# Process Outputs

If your instrument is equipped with process outputs, these outputs must be installed and activated before they can be used.

To install an output, you must:

- Define the measured value that should be transmitted to the output (source item) and the properties of the signal.
- Define the output parameter if no valid measured values are available.

The installed output must be activated (program branch `OUTPUT OPTIONS`). Only after this procedure has been completed will measured values be available at the outputs.

## Installation of a Process Output

The installation of the process outputs takes place in the `SPECIAL FUNCTION \ SYSTEM SETTINGS \ PROCESS OUTPUTS` program branch.

**Note:** The Portalok 7S stores the configuration of an output at the end of the installation dialogue. If you exit the installation dialogue by pressing **BRK**, changes won't be saved.

```
SYSTEM settings ⬆
Proc. outputs
```

In the `SPECIAL FUNCTION \ SYSTEM SETTINGS` program branch, select the `PROCESS OUTPUTS` option. Confirm by pressing **ENTER**.

```
Install Output ⬆
Current I1
```

Select the output you want to install. The scroll list contains all the available process outputs. A tick (✓) after an item of the list means that this output has already been installed. Confirm by pressing **ENTER**.

```
I1 enable
no >YES<
```

This display will appear if the selected output was not already enabled.

Select **YES** and confirm by pressing **ENTER**.

```
I1 disable
>NO< yes
```

If the selected output was already enabled, select **NO** to reconfigure it, or **YES** to return to the previous menu and select another output.

Confirm by pressing **ENTER**.

```
I1 Source item ⬆
Flow
```

Select the measuring quantity to be transmitted to the output (source item). The available source items and their configuration option are described in the table below. If you are configuring a binary output, only the options `LIMIT` and `IMPULSE` are offered.

### Configuration options for the process outputs

Source item	Available configuration options	Output
Flow	-	Output of the measuring quantity selected in program branch <code>OUTPUT_OPTIONS</code>
Quantity	Q+ Q- ΣQ	Output of the totalizer for the <b>positive</b> flow direction Output of the totalizer for the <b>negative</b> flow direction Output of the <b>sum</b> of the totalizers
Limit	R1 R2 R3	Output of a limit message (alarm output R1) Output of a limit message (alarm output R2) Output of a limit message (alarm output R3)
Impulse	From abs (x) from x > 0 from x < 0	Impulse output without sign consideration Impulse output for positive measured values Impulse output for negative measured values
Miscellaneous	Soundspeed fluid Signal	Output of the sound velocity (see chapter ). Output of the amplitude of the signal

## Output Range

```
I1:Output range ↕
      4/20 mA
```

If you are configuring an analogue output, EESIFLO requests the output range. Select one of the ranges offered in the scroll list or `OTHER_RANGE` to enter manually the output range.

```
I1:Output MIN ↕
      10.0 mA
```

If you have selected `OTHER_RANGE`, enter the minimal output value (`OUTPUT_MIN`) and the maximum output value (`OUTPUT_MAX`).

```
I1:Output MAX ↕
      11.0 mA
```

Confirm each value with **ENTER**.

```
I1:Output MAX ↕
      12.0 MINIMAL
```

The entered output range should cover at least 10% of the full physical output range ( $I_{MAX} - I_{MIN} \geq 2\text{mA}$  for a 20 mA current loop for example). If this is not the case, Portalok 7S will display the smallest maximum value (`OUTPUT_MAX`) possible for the entered minimal output value (`OUTPUT_MIN`).

## Output Value in Case of Error

You can also select that value which the Portalok 7S shall transmit if the assigned source item cannot be measured or located. For example, the Portalok 7S might not be capable of measuring the flow during a certain period because of the presence of gas bubbles in the medium. It will then output the defined "error value".

**Error value options**

Error value option	Result
Minimum	Output of the lowest possible value (lower limit of the output range)
Hold last value	Output of the last measured value
Maximum	Output of the highest possible value (upper limit of the output range)
Other value	Output of a value to be defined within the physical limits of the output.

**Example:**

The flow volume was selected as source item for the current loop, the current loop range was set to 4/20 mA, the error value delay  $t_d$  to a value greater as zero.

The measurement of the volume flow rate is impossible during the time interval  $t_0 \dots t_1$ .

What signal should be output during this time interval?

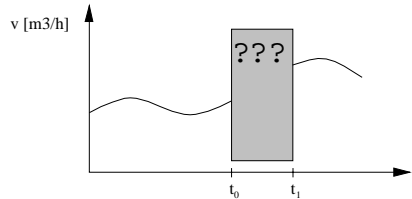

**Error value delay**

**Error value options**

Selected error value option	Output signal
<div style="border: 1px solid gray; padding: 5px; width: fit-content;">                     Error-value <span style="float: right;">⇅</span>                      Minimum (4.0mA)                 </div>	
<div style="border: 1px solid gray; padding: 5px; width: fit-content;">                     Error-value <span style="float: right;">⇅</span>                      Hold last value                 </div>	
<div style="border: 1px solid gray; padding: 5px; width: fit-content;">                     Error-value <span style="float: right;">⇅</span>                      Maximum (20.0mA)                 </div>	
<div style="border: 1px solid gray; padding: 5px; width: fit-content;">                     Error-value <span style="float: right;">⇅</span>                      Other value ...                 </div> <p>Error-Value = 2.00 mA</p>	

```
Error-value  ⬆
Minimum (4.0mA)
```

Select an error value in the scroll list.  
Confirm by pressing **ENTER**.

```
Error-value:
...
```

If you have selected **OTHER VALUE**, enter an error value now. The value must be within the physical limits of the process output.  
Confirm by pressing **ENTER**.

**Note:** The Portalok 7S stores your settings at the end of this dialogue.

```
I1 active loop
Terminal:P1+,P1-
```

The terminals for the connection of the outputs are now displayed (here: P1+ and P1- for the active current loop).  
Confirm by pressing **ENTER**.

## Function Check

Finally, you can test the function of the installed output. Connect the terminals assigned to the output you have installed to a multimeter.

### Test of analogue outputs

```
I1:Output Test
4 mA
```

Enter a test value (in our example, the current output is tested). The test value should be in the selected output range.  
Confirm by pressing **ENTER**.

```
I1= 4.0 mA
Again? no >YES<
```

The input functions correctly if the measuring instrument displays the entered value.  
Select **YES** to repeat the test, **NO** to return to the **SYSTEM SETTINGS**.  
Confirm by pressing **ENTER**.

### Test of binary outputs

```
B1:Output Test
Reed-Relais OFF
```

In the **OUTPUT TEST** scroll list, select **OFF** to test the de-energized state of the output.  
Confirm by pressing **ENTER**.  
No current should be flowing at the output now.

```
B1= OFF
Again? no >YES<
```

Select **YES**.  
Confirm by pressing **ENTER**.

```
B1:Output Test
Reed-Relais ON
```

In the OUTPUT TEST scroll list, select ON to test the energized state of the output.  
Confirm by pressing **ENTER**.  
A current should be flowing now.

```
B1= ON
Again? no >YES<
```

Select YES to repeat the test, NO to return to the SYSTEM SETTINGS.  
Confirm by pressing **ENTER**.

## Defining the Error Value Delay

The error value delay is the time interval after which the Portalok 7S will transmit the error value to the output if no valid measured values are available.

The error value delay can be entered in the OUTPUT OPTIONS program branch if this inquiry has been previously activated in the program branch SPECIAL FUNCTION. If you don't enter a specific value for the delay, Portalok 7S will use the damping value.

```
Error-val.delay
>DAMPING< edit
```

In the SPECIAL FUNCTION \ SYSTEM SETTINGS \ DIALOGS/MENUS program branch, select the ERROR-VAL. DELAY option.

```
Error-val.delay
10 s
```

Select DAMPING if you wish the damping factor to be used as error-value delay (default setting). Select EDIT to activate the error value delay inquiry. From now on, the Portalok 7S will request the error value delay in the program branch OUTPUT OPTIONS.

This setting is coldstart resistant.

## Activation of an Analogue Output

**Note:** An output can only be activated in the program branch OUTPUT OPTIONS if it has been previously installed.

```
par mea >OPT< sf
Output Options
```

In the main menu, select the program branch OUTPUT OPTIONS.

```
Current Loop
I1: no >YES<
```

Select YES in the display of the output to be activated.  
Confirm by pressing **ENTER**.

## Scale Values for the Analogue Outputs

After you have activated an analogue output in the program branch OUTPUT OPTIONS, EESIFLO will request the scale values for the source item.

```
Zero-Scale Val.  
0.00 m3/h
```

```
Full-Scale Val.  
300.00 m3/h
```

Enter as ZERO-SCALE VALUE the lowest measured value expected. The displayed measuring unit is the unit of the source item of the output. The ZERO-SCALE VALUE is the measured value corresponding to the lower limit of the output range

Enter as FULL-SCALE VALUE the highest measured value expected. The FULL-SCALE VALUE is the measured value corresponding to the upper limit of the output range

Example :

*The output range 4/20 mA was selected for a current loop, the zero-scale value was set to 0 m<sup>3</sup>/h and the full-scale value to 300 m<sup>3</sup>/h.*

*A signal of 20 mA will be transmitted to the current output when a flow rate of 300 m<sup>3</sup>/h is measured. For a measured current of 0 m<sup>3</sup>/h, a signal of 4 mA will be transmitted.*

## Activation of a Pulse Output

A pulse output is an integrating output which emits a pulse when the medium volume or the medium mass which has passed the measuring point attains a given value (=PULSE VALUE). The integrated quantity is the selected quantity of measurement. Integration is restarted when a pulse is emitted.

<b>Note:</b> The display PULSE OUTPUT only appears in the program branch OUTPUT OPTIONS if a pulse output has been installed.
---

```
par mea >OPT< sf  
Output Options
```

In the main menu, select the program branch OUTPUT OPTIONS.

```
Pulse Output  
Bl: no >YES<
```

Select YES in the display of the output to be activated.

Confirm by pressing **ENTER**.

```
Pulse Output  
NO COUNTING!
```

If the flow velocity is selected as the quantity of measurement, an error message is displayed.

```
Pulse Value  
0.01 m3
```

Enter the PULSE VALUE. EESIFLO automatically displays the unit of the actual measuring quantity. When the totalized measuring quantity reaches the pulse value, a pulse will be emitted.

```
Pulse Width  
100 ms
```

Enter the PULSE WIDTH. Values between 80 and 1000 milliseconds are accepted. The range of possible pulse widths depends on the specifications of the instrument (e.g. counter, totalizer, PLC) which will be connected with the pulse output.



The Portalok 7S then displays the maximum possible flow in the pipe that the pulse output can work with. This value is calculated from the data given for pulse value and pulse width. If the actual flow exceeds this 'Max-Value', the pulse output will not function properly. In such a case, the pulse value and pulse width should be changed to accommodate the flow conditions. Confirm the maximal value by pressing **ENTER**.

**Attention!** If the actual flow rate exceeds this 'Max-Value', the pulse output will not function correctly.

## Activation of an Alarm Output

**Note:** The display `ALARM OUTPUT` only appears in the program branch `OUTPUT OPTIONS` if an alarm output has been installed.

A maximum of three alarm outputs operating independently of each other can be linked. The alarm outputs can be used for the output of status information about the ongoing measurement or to start and stop control pumps, electrical motors or other equipment.

## Setting the Alarm Properties

You can define the switching condition, the type (the holding state) and the mode (the state in de-energized condition) of the alarm output. The settings are described in the following table:

### Alarm properties

Alarm property	Available settings	Description
<b>FUNC</b> (switching condition)	<b>MAX</b>	Alarm switches when the measured value exceeds the upper limit.
	<b>MIN</b>	Alarm switches when the measured value falls below the lower limit.
	<b>+⇒ - -⇒ +</b>	Alarm switches when the flow changes its direction (sign change of measured value).
	<b>QUANTITY</b>	Alarm switches when the totalizing function is activated and the totalizer reaches or exceeds the programmed limit.
	<b>ERROR</b>	Alarm switches when no measurement is possible.
<b>TYP</b> (holding behavior)	<b>OFF</b>	No function, the alarm is not working..
	<b>NON-HOLD</b>	Alarm returns to idle state after approx. 1 second if the switching condition is not true any more.
<b>MODE</b> (alarm state in de-energized condition)	<b>HOLD</b>	Alarm stays activated even if the switching condition is not true any more.
	<b>NO Cont.</b>	Alarm is energized when the switching condition is true, i.e. de-energized when idle (NO=normally open).
	<b>NC Cont.</b>	Alarm is de-energized when the switching condition is true, i.e. energized when idle (NC=normally closed).

**Attention:** When EESIFLO is not measuring, all alarms are in de-energized state, independently of the programmed function.

```
par mea >OPT< sf
Output Options
```

In the main menu, select the program branch `OUTPUT OPTIONS`.

```
Alarm Output
no >YES<
```

Select **YES** in the display of the output to be activated. Confirm by pressing **ENTER**.

```
R1=FUNC<typ mode
Function:    MAX
```

The display that then appears contains three scroll lists:

- FUNC for setting the switching condition,
- TYP for setting the holding state,
- MODE for setting the state in de-energized condition.

Use left and right arrow keys to select an scroll list on the first line.

Use left and right arrow keys to select the corresponding setting on the second line.

Press **ENTER** to confirm the selected settings at the end of selection.

## Setting the Limit Values

For the functions **MAX** and **MIN**

If you have selected the switching condition **MAX** or **MIN** under **FUNC**, you can enter the desired limit values for the alarm outputs as follows:

```
R1 Input:    ↕
Volume Flow
```

Select in the **INPUT** scroll list which physical quantity should be used for comparison. Available options are:

- the volume flow,
- the signal amplitude,
- the sound velocity for the medium.

Confirm by pressing **ENTER**.

EESIFLO will then request the value of the limit.

### Limit values

Function	Display and comparison	Remarks
MAX	<pre>High Limit: -10.00 m3/h</pre> <p>Comparison: measured value &gt; limit</p> <p>The alarm output switches when the measured value exceeds the programmed limit.</p>	<p>The sign is taken into account!</p> <p><i>Example:</i></p> <p><i>High limit = -10.0 m<sup>3</sup>/h</i></p> <p><i>The limit will be exceeded by a measured value of -9.9 m<sup>3</sup>/h or +2.5 m<sup>3</sup>/h. The alarm won't switch if, for instance, the measured value amounts to -11.0 m<sup>3</sup>/h.</i></p>
MIN	<pre>Low Limit: -10.00 m3/h</pre> <p>Comparison: measured value &lt; limit</p> <p>The alarm output switches when the measured value falls below the programmed limit.</p>	<p>The sign is taken into account!</p> <p><i>Example:</i></p> <p><i>Low limit = -10.0 m<sup>3</sup>/h</i></p> <p><i>The limit will be exceeded by a measured value of -11.0 m<sup>3</sup>/h or -22.5 m<sup>3</sup>/h. The alarm won't switch if, for instance, the measured value amounts to -9.9 m<sup>3</sup>/h.</i></p>

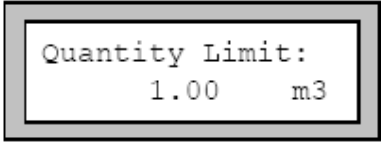
QUANTITY	 <p>Comparison: totalizer value <math>\geq</math> limit</p> <p>The alarm output switches when the totalizer reaches the programmed limit.</p>	<p>Portalok 7S has a totalizer for each flow direction (positive and negative).</p> <p>If you enter a <b>positive limit</b>, the comparison will be made with the totalizer value for positive flow direction. If you enter a <b>negative limit</b>, the comparison will be made with the totalizer value for negative flow direction.</p> <p>The comparison will also be made if the totalizer of the other flow direction has been selected for displaying.</p>
----------	--	---

**Note:** During measurement, the limit values will always be interpreted in terms of the unit of measurement that was selected at the time the quantity limit was set. The limit value stays the same even if the quantity and/or unit of measurement is changed. If you change the unit of measurement, also change the quantity limit.

*(Example: You have entered a limit value of 60.0 m<sup>3</sup>/h, then changed the unit of measurement to m<sup>3</sup>/min. You should also change the quantity limit from 60.0 m<sup>3</sup>/h to 1.0 m<sup>3</sup>/min).*

## Defining the Hysteresis

It is now possible to define the hysteresis for the alarm.

This function is useful to avoid a constant triggering of the alarm by measuring values fluctuating around the limit. The hysteresis is a symmetrical range around the limit in which fluctuation is permitted. The alarm will be activated when the measuring values reach the upper limit of this range and deactivated when the measuring values fall below the lower limit.

*Example: For an hysteresis of 1 m/s and a limit of 30 m/s, the alarm will be activated at 30.5 m/s and deactivated at 29.5 m/s. Small fluctuations around 30 m/s won't have any effect on the alarm.*

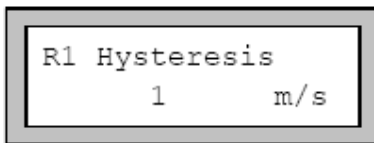

Enter the desired value or enter "0" (zero) if you do not require hysteresis.

Confirm by pressing **ENTER**.

## Operation of the Alarm Outputs

### Apparent Delays when Alarm Outputs switch

The Portalok 7S rounds the measured value and totalizer value with a precision of two decimal places behind the decimal separator before they are displayed. However, the Portalok 7S compares the limits with the non-rounded values. This might cause an apparent output switching delay, especially when extremely small changes of the measured value take place (smaller than the equivalent of two decimal places behind the comma). In these cases the accuracy of the output switching is higher than the accuracy of the display.

## Reset and Initialization of the Alarms

- After a coldstart, all alarm outputs will be initialized. They will then be in the following state:

#### State of the output after initialization

FUNC:	OFF
TYPE:	NON HOLD
MODE:	NO CONT.
LIMIT:	0.00

- During measurement, pressing key **C** three times will switch all alarms to their idle state. However, all alarms which switching condition is still met will switch back into their active state after 1 second. Use this function to reset an alarm of type `HOLD` when the switching condition is not met anymore.
- Pressing **B** stops measurement and returns to the main menu. All alarms are switched to their de-energized state, independently of their programmed idle state.

## Alarm Outputs in the Parameter Record

The configuration of the alarm outputs will be stored with the current parameter record (program branch `SPECIAL FUNCTION`). Thus, the configuration of the alarm outputs will also be loaded when a stored parameter record is loaded.

## Alarm Outputs during Transducer Positioning

When the positioning of the transducers begins (bar graph display), all alarms outputs switch to their programmed idle state.

If you return to the bar graph display during measurement, the alarms will switch back to their programmed idle state. An alarm output of the type `HOLDING` which has switched during the previous measurement will remain in its programmed idle state after completion of the transducer positioning if the switching condition is not met any more.

You can obtain the same result by pressing key **C** three times during measurement. The switching of the alarms into their programmed idle state is not indicated on the display.

## Alarm Output during Measurement

Alarms with switching condition `MAX` or `MIN` will be updated once per second at most in order to avoid 'humming' (a permanently fluctuating measured value around the limit constantly triggering the alarm).

Alarms of type `NON-HOLD` will switch in their activated state for about 1 second when the switching condition is met.

Alarms with switching condition `QUANTITY` will immediately switch in their activated state when the totalizer value reaches or exceeds the limit.

Alarms with switching condition `ERROR` will only switch in their activated state after several unsuccessful measuring attempts. Therefore, typical short-term disturbances of the measurement as, for example, air bubble caused by pumps being switched on, will not activate the alarm. If the alarms are of type `NON-HOLD`, they will switch back as soon as a valid measured value is obtained.

If there is an internal adaptation to changing measuring conditions, e.g. to a considerable rise of the medium temperature, the alarm will not switch.

Alarms with the switching condition `OFF` will automatically be set to the mode `NO CONT.` The alarm is de-energized.

Alarms with switching condition +⇌- -⇌+ (sign change) and type NON-HOLD will switch in their activated state for about 1 second with any change of flow direction.

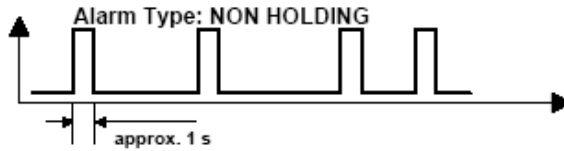
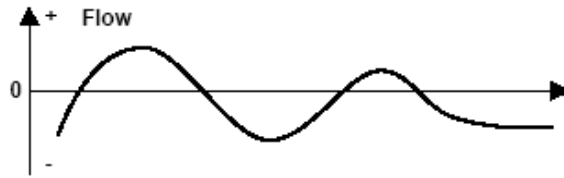

Alarms with switching condition +⇌- -⇌+ (sign change) and type HOLD will switch in their activated state with the first change of flow direction and stay in this state. They can be switched back by pressing the key C three times.

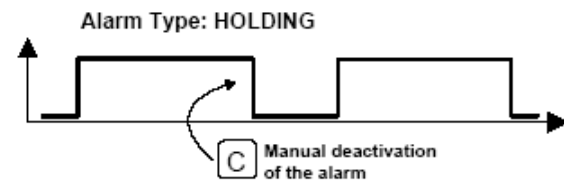

Behavior of a relay when the flow direction changes

## Alarms' State

**Note:** There is no visual or acoustic indication of alarm switching or resetting.

It is possible to have the state of the alarms displayed during measurement. This function can be activated in program branch SPECIAL FUNCTION \ SYSTEM SETTINGS \ DIALOGS/MENUS. This setting is coldstart resistant.

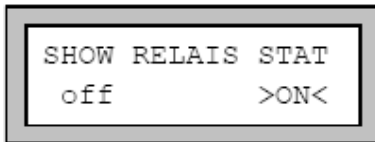

Select the SHOW RELAIS STAT option. Select ON to activate the display of the alarms' state.

During measurement, press key to scroll on the first line of the display until you reach the alarm's state display.

The alarm's state is displayed in the following form:

RX =     , where  represents a pictogram (R1 = for example).

## Deactivating the Outputs



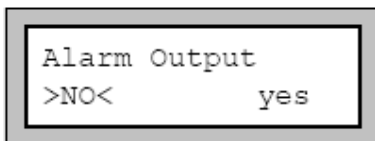













If you no longer require a programmed output, it can be deactivated. The configuration of the deactivated output is stored and will be available when the output is re-activated.



Deactivate the outputs by selecting NO in the respective display of the program branch OUTPUT OPTIONS.

Confirm by pressing ENTER.

**Pictograms of the alarm's state display**

	Nr.	Function	Type	Switching condition	Actual state
R		= 			
	1	 no function	 NON-HOLD	 NO (normally open)	 CLOSED
	2	 MAX	 HOLD	 NC (normally closed)	 OPEN
	3	 MIN			
		 + → - - → +			
		 QUANTITY			
		 ERROR			

# Troubleshooting

## First Step: Which of the followings describes the best your problem?

**a) The display does not work at all or always turns off.**

If the power supply is ok, the transducers or an internal component of the transmitter are defective. Send the transmitter and the transducers to **EESIFLO** for repair.

**b) The message "System Error" is displayed.**

Press **B** to return to the main menu.

If this happens several times, note the code displayed on the lower line of the display, write down in which situation the error occurred and contact **EESIFLO**.

**c) The flowmeter doesn't react when B is pressed during measurement.**

A program code has been defined. Press key **C** and enter the program code.

**d) The backlight of the display does not turn on, but everything else works.**

The backlight is defective. Send the instrument to **EESIFLO** for repair. This problem has no influence on the other functions of the display..

**e) The date and time displayed are wrong and measured values are deleted when the flowmeter is switched off.**

The data backup battery must be replaced. Send the instrument to **EESIFLO**.

**f) A process output doesn't work.**

Ensure that the outputs are configured correctly. Control the function of the output as described in Process output section .

**g) Measurement is impossible or the measured values substantially differ from the expected values.**

Contact experienced EESIFLO personnel.

**h) The totalizer values are wrong.**

Check your settings.

If any problem appears which cannot be solved with the help of this booklet, please contact **EESIFLO**, giving a precise description of the problem. Don't forget to specify the model, serial number and firmware version of your instrument.

## Calibration

The EESIFLO Portalok 7S series is a very reliable instrument. It is manufactured under strict quality control, using modern production techniques. If installed correctly, as recommended, the Portalok 7S will be an invaluable tool for flow measurement.. The instrument has been calibrated at the factory and usually, a re-calibration of the flowmeter won't be necessary.

However, a new calibration might be advisable if:

- the surface of the transducers show visible wear
- if the transducers were used for a prolonged period at a high temperature (many months at a temperature of more than 130°C for normal transducers or of more than 200°C for high temperature transducers).

In this case, the instrument will have to be sent to **EESIFLO** for calibration under reference conditions.

# Problems with the Measurement

a) **Measurement is impossible because no signal can be detected.** A question mark appears at the right side of the lower display line.

- Ensure that the entered parameter are correct, especially the outer diameter of the pipe, the wall thickness and the sound velocity.

(Typical errors: the circumference or the radius was entered instead of the diameter. The inner diameter was entered instead of the outer diameter).

- Ensure that the transducer distance recommended by the Portalok 7S was used when mounting the transducers.
- Ensure that the selected measuring point is suitable.
- Try to obtain better acoustic contact between the pipe and the transducers.
- Try to measure with a smaller number of transit paths. The signal attenuation might be too high because of a high fluid viscosity or of the presence of deposits on the inner pipe wall.
- Contact EESIFLO for Application Specific Problems".

b) **The measuring signal was found but no measuring value can be obtained.**

If an exclamation mark "!" is displayed at the right of the measuring units, the measured values are greater than the velocity limit and are thus invalid. The velocity limit should be adapted to the measuring situation or the velocity check should be deactivated (velocity limit = 0).

If no exclamation mark "!" is displayed: Measurement is fundamentally impossible at the selected measuring point.

c) **Loss of Signal during Measurement**

- Did the pipe run empty and then fill up again? In this case, consult **EESIFLO**.

Wait a little while until the acoustic contact is established again. There might be a temporary higher proportion of gaseous or solid particles in the flowing medium. If measurement does not resume, proceed as described in a).

d) **Measuring values substantially differ from the expected values.**

Wrong measuring values are often caused by false parameters. Make sure the parameters entered are correct for the point at which you are measuring.

Correct Selection of the Measuring Point

- Check the recommended straight pipe run before and after any disturbance source..
- When measuring on horizontal pipes, the transducers should be mounted on the side of the pipes. Avoid locations where deposits are building in the pipe.
- The pipe should always be filled at the measuring point, and the liquid must flow upward.
- No bubbles should accumulate (even bubble-free liquids can form gas pockets at places where the liquid expands, e.g. especially behind pumps and where the cross-sectional area of the pipe extends considerably).
- Avoid measuring points in the vicinity of deformations, defects in the pipe or in the vicinity of welding joints.
- Measure the temperature at the measuring point and ensure that the transducers used are adequate for this temperature.

**Note:** If the temperature at the measuring point fluctuates, it is very important that the two inner hooks of the clasp are engaged in the tension strap. Otherwise, the pressure on the transducer will be insufficient when the temperature goes down. During high temperature fluctuations, EESIFLO recommended utilizing the tensions straps with integrated spring which will compensate for the diameter fluctuation caused by thermal expansion.

- Ensure that the pipe diameter is within the measuring range of the transducers.



# Maximum Acoustic Contact

**In order to obtain maximal acoustic contact between the pipe and the transducers, check the following:**

- The pipe must be clean and free of loose paint or corrosion/bitumen etc. You must be able to see the surface of the actual pipe  
Rust or other deposits absorb the acoustic signals. Clean the pipe at the selected measuring point. Remove rust or loose paint.
- Grind off any thick layer of paint.
- Always apply a bead of acoustic coupling compound lengthwise down the center of the contact surface of the transducers.
- Ensure that the mounting fixture applies the necessary pressure on the transducers. There should be no air pockets between transducer surface and pipe wall.

## Application Specific Problems

**The entered sound velocity might be wrong.** The sound velocity is used by the flowmeter to determine the transducer distance and is therefore very important for transducer positioning. The sound velocities programmed in the flowmeter should only serve as orientation values. It might be necessary to have the sound velocity of the medium measured.

**The value entered for the pipe roughness** might be incorrect. Reconsider the entered value, taking into account the state of the pipe.

**Measurements on porous pipe materials** (e.g. concrete or cast iron) are only possible under certain conditions. Consult **EESIFLO**.

**Lined pipes might cause problems** if the lining is not bonded correctly to the pipe wall or consists of a material which has bad acoustic characteristics. Try measuring on a liner free section of the pipe work.

**Media with high viscosity** strongly attenuate the ultrasonic signals. Measurements on media with viscosity higher than 1000 mm<sup>2</sup>/s are only possible under certain conditions.

**Particles scatter and absorb ultrasounds** and therefore attenuate the signal. Measurement is unlikely if the proportion of solid particles or gas bubbles is of 10% or more. If the latter is high, but less than 10%, measurements might be possible under certain conditions.

**The flow might be in the transition range** between laminar and turbulent flow where flow measurement is problematic. Check the Reynolds number of the flow at the measuring point and consult **EESIFLO**.

## Measurement Data Substantially Differs from the Expected Value

**Possible causes for wrong measured values:**

- A wrong sound velocity for the medium.  
A wrong value of the sound velocity could lead the user to identify the ultrasonic signal that was reflected on the pipe wall and did not cross the medium as the measuring signal. The measured flow rate will then be very small or fluctuate around zero.
- There is gas in the pipe.  
If there is gas in the pipe, the measured volume flow rate will always be too high, since both the gas volume and the medium volume are being measured.
- The upper limit for the flow velocity is too low.

The measured flow velocities that are greater than the defined upper limit are ignored and marked as outlier. All quantities derived from the flow velocity are equally ignored. If a certain number of correct measuring values are higher than the limit, the totalized values (the volume flow rate for example) will be too small.

- The defined cut-off flow is too high.

All flow velocities below the cut-off are set to zero, as well as all quantities derived from these flow velocities. To measure small flow velocities, the cut-off flow (default value 5 cm/s) must be set to an appropriate value.

- The pipe roughness is inappropriate.
- The flow velocity to be measured is outside the measuring range of the transducers.
- The measuring point is inadequate.

Try measuring somewhere else on the pipework and see if the results are better. Pipes are never perfectly round and this influences the flow profile. Try re-positioning of the transducers and avoid deformations of the pipe.

## Problem with the Totalizers

- If the totalizer values are too large:

Check `SPECIAL FUNCTIONS\SYSTEM SETTINGS\MEASURING\QUANTITY RECALL`.

If this option is activated, the totalizer value of a measurement is saved. The totalizer will use this value at the start of the next measurement.

- If the totalizer values are too small:

One of the totalizers might have reached the internal limit. It must be reset to zero manually.

- If the output of the sum of the totalizers is not correct:

Check `SPECIAL FUNCTIONS\SYSTEM SETTINGS\MEASURING\QUANT. WRAPPING`.

The output of the sum of both totalizers via a process output is not valid after the first overflow (wrapping) of one of the respective totalizers.

# A Specifications

Specifications are subject to modifications without prior notice.

## EESIFLO Portalok 7S Series Portable Flowmeter

### Measuring

Measuring principle:	Ultrasonic time difference correlation principle
Flow velocity:	(0.01...25) m/s
Resolution:	0.025 cm/s
Repeatability:	0.25% of reading $\pm$ 0.02 m/s
Accuracy	(for fully developed, rotationally symmetrical flow profile)
- Volume flow:	$\pm$ 1% ..3% of reading $\pm$ 0.02 m/s depending on application $\pm$ 0.5% of reading $\pm$ 0.02 m/s with process calibration
Measurable fluids:	all acoustically conductive fluids with < 10% gaseous or solid content in volume

### Transmitter

Enclosure	
- Weight:	3 kg
- Degree of protection:	Designed to IP68
- Material:	High density Polyethylene
Measuring channels:	1
Power supply:	(100-240) VAC and Battery operated
Display:	2 x 16 characters, dot matrix, backlit
Operating temperature:	-10°C...60°
Power consumption:	< 10 W
Signal damping:	(0...100) s, adjustable
Measuring cycle:	(100...1000) Hz (1 channel)
Response time:	1 s (1 channel)

### Measuring functions

Quantities of measurement:	Volume and mass flow rate, flow velocity
Totalizers:	Volume, mass
Calculation functions:	Average/Difference/Sum
Built in Datalogger	Approx. 60,000 values
Operating languages:	English

### Process outputs

- all outputs galvanically isolated from main device	
- The basic instrument is equipped with 1 current output and 2 binary outputs	
Current	active: $R_{ext} < 500 \Omega$
- Measuring range:	(0/4...20) mA
- Accuracy:	0.1% of reading $\pm$ 15 $\mu$ A
Binary	open collector: 24 V/4 mA

reed contact:	48 V/0.1 A
as state output:	limit, sign change or error
as pulsed output:	Pulse value: (0.01...1000) units Width: (80...1000) ms

### Flow transducers (clamp-on)

<b>Type P</b>	
Rated (possible) diameter range:	(12.5) 25 to 1000 mm
Dimensions:	ca. (60 x 30 x 33.5) mm
Operating temperature:	-30°C...100°C
Degree of protection:	IP68
Material	Teka peek
Standard cable	10M length

Specifications

**Units of Measurement**

Volume flow	Flow velocity	Mass flow	Totalizers		Sound velocity
			Volume	Mass	
m <sup>3</sup> /h	m/s	g/s	m <sup>3</sup>	g	m/s
m <sup>3</sup> /min	inch/s	t/h	l	kg	
m <sup>3</sup> /s		kg/h	gal	t	
l/h		kg/min			
l/min					
l/s					
USgph					
USgpm					
USgps					
bb/d					
bb/h					
bb/m					

1 gallon [US] = 3.78 l; 1 barrel = 42 gallons = 158.76 l

Specifications

# Flow Nomogram

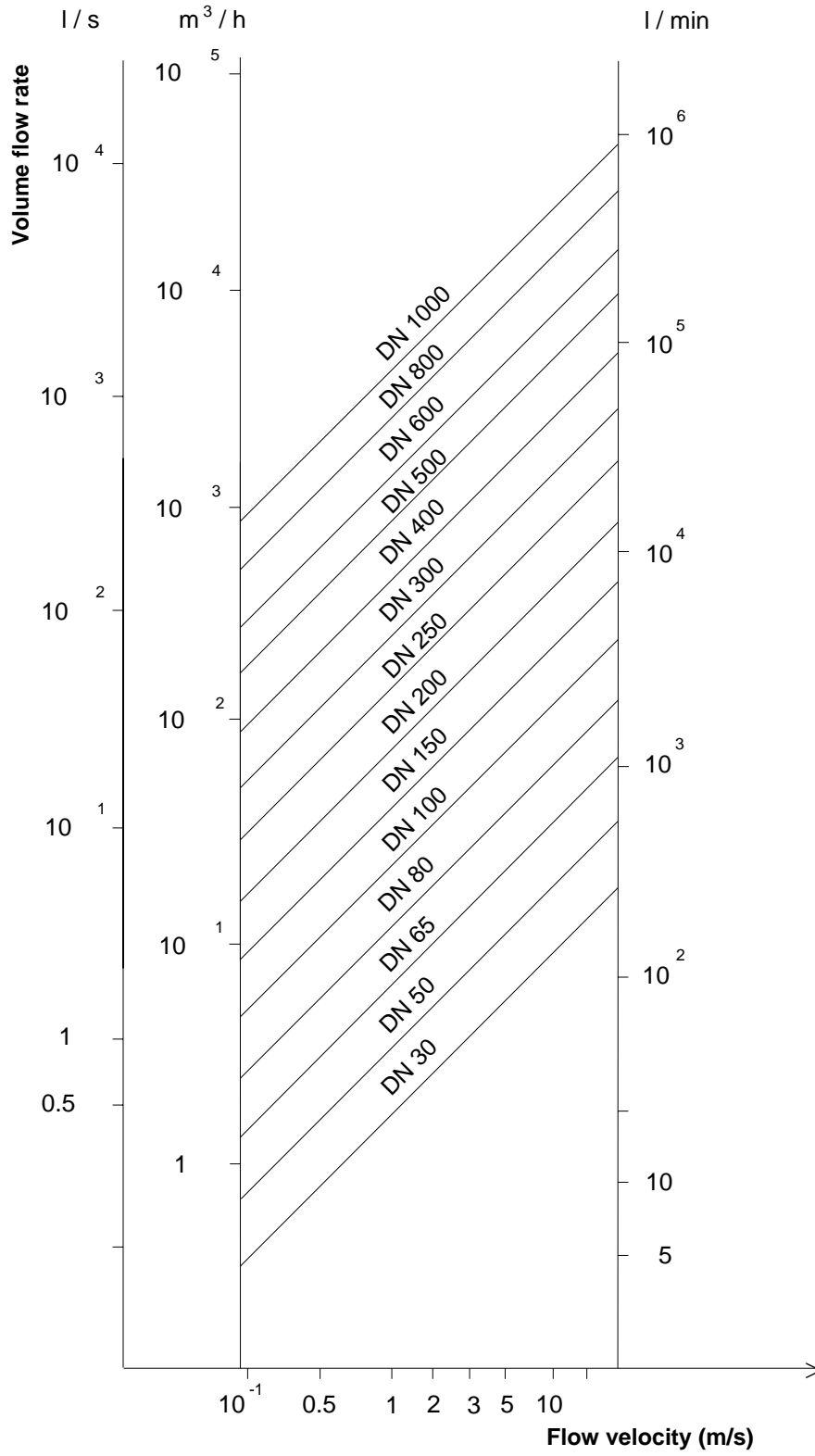

## B Reference

The content of the tables has been compiled to help the user. The accuracy of the given data depends on the composition, the temperature and the manufacturing process of the respective material. EESIFLO does not accept liability for possible inaccuracies.

### Table B . : Sound velocity of some current pipe and lining materials at 20°C

This table indicates the longitudinal and transversal sound velocities of some pipe and liner materials at 20°C. The grey highlighted values are not stored in the EESIFLO data bank. In the **C<sub>flow</sub>** column, the sound velocity (longitudinal or transversal) used by EESIFLO for flow measurement is indicated. In the case of your particular measurement problem, remember that the sound velocity depends on the composition and on the manufacturing process of the material. The sound velocity of alloys and cast material will fluctuate over a certain range; The velocities stated herein should be used as a guideline..

Material	C <sub>trans</sub> [m/s]	C <sub>long</sub> [m/s]	C <sub>flow</sub>	Material	C <sub>trans</sub> [m/s]	C <sub>long</sub> [m/s]	C <sub>flow</sub> [m/s]
Aluminum	3100	6300	trans	Platinum	1670		trans
Asbestos cement	2200		trans	Polyethylene	925		trans
Bitumen	2500		trans	Polystyrene	1150		trans
Brass	2100	4300	trans	PP	2600		trans
Carbon steel	3230	5800	trans	PVC		2395	long
Copper	2260	4700	trans	PVC hard	948		trans
Cu-Ni-Fe	2510		trans	PVDF	760	2050	long.
Ductile iron	2650		trans	Quartz glass	3515		trans
Glass	3400	4700	trans	Rubber	1900	2400	trans
Grey cast iron	2650	4600	trans	Silver	1590		trans
Lead	700	2200	long	Sintimid		2472	long
PE		1950	long	Stainless steel	3230	5790	trans
Perspex	1250	2730	long	Teka PEEK		2537	long
PFA		1185	long	Tekason		2230	long
Plastic	1120	2000	long	Titanium	3067	5955	trans

## Table B . : Typical roughness coefficients for pipes

For your convenience, we have already pre-programmed common roughness coefficients for pipe materials. The data are based upon experience with measurements performed with these pipe materials.

Pipe wall material	Absolute roughness [ $\mu\text{m}$ ]	Pipe wall material	Absolute roughness [ $\mu\text{m}$ ]		
Drawn pipes of non-ferrous metal, glass, plastics and light metal	0 ... 1.5	Cast iron pipes <ul style="list-style-type: none"> <li>• bitumen lining</li> <li>• new, without lining</li> <li>• rusted</li> <li>• encrusted</li> </ul>			
Drawn steel pipes fine-planed, polished surface	10 ... 50 up to ... 10		120 ... 1000		
planed surface	10 ... 40		1000 ... 1500		
rough-planed surface	50 ... 100		1500 ... 3000		
Welded steel pipes, new	50 ... 100				
long usage, cleaned	150 ... 200				
lightly and evenly rusted	up to ... 400				
heavily encrusted	up to ... 3,000				

## Table B. : Typical properties of media at T=20°C and P = 1 bar

Medium	Sound velocity [m/s]	Kinematic viscosity [ $\text{mm}^2/\text{s}$ ]	Density [ $\text{g}/\text{cm}^3$ ]
30% Glycol / H <sub>2</sub> O	1671	4.0	1.045
50% Glycol / H <sub>2</sub> O	1704	6.0	1.074
80% Sulphuric acid	1500	3.0	1.700
96% Sulphuric acid	1500	4.0	1.840
Acetone	1190	0.4	0.790
Ammonia	1660	1.0	0.800
Petrol	1295	0.7	0.880
BP Transcal LT	1415	13.9	0.740
BP Transcal N	1420	73.7	0.750
CaCl <sub>2</sub> -15 C	1900	3.2	1.170
CaCl <sub>2</sub> -45 C	2000	19.8	1.200
Cerium solution	1570	1.0	1.000
Ethyl ether	1600	0.3	0.716
Glycol	1540	17.7	1.260
H <sub>2</sub> O-Ethan.-Glyc.	1703	6.0	1.000
HLP32	1487	77.6	0.869
HLP46	1487	113.8	0.873
HLP68	1487	168.2	0.875
ISO VG 22	1487	50.2	0.869
ISO VG 32	1487	78.0	0.869
ISO VG 46	1487	126.7	0.873
ISO VG 68	1487	201.8	0.875
ISO VG 100	1487	314.2	0.869
ISO VG 150	1487	539.0	0.869
ISO VG 220	1487	811.1	0.869
Copper sulphate	1550	1.0	1.000
Methanol	1121	0.8	0.791

## Reference

Medium	Sound velocity [m/s]	Kinematic viscosity [mm <sup>2</sup> /s]	Density [g/cm <sup>3</sup> ]
Milk 0.3% fat	1511	1.5	1.030
Milk 1.5% fat	1511	1.6	1.030
Milk 3.5% fat	1511	1.7	1.030
Oil	1740	344.8	0.870
Quintolubric 200	1487	69.9	0.900
Quintolubric 300	1487	124.7	0.920
R134 Freon	526	1.0	1.000
R22 Freon	563	1.0	1.000
Hydrochloride acid 37%	1520	1.7	1.200
Sour cream	1550	50.0	1.000
Shell Thermina B	1458	74.5	0.863
SKYDROL 500-B4	1387	21.9	1.057
Toluene	1305	0.6	0.861
Vinyl chloride	900	---	0.970
Water	1482	1.0	0.999
Zinc powder suspension	1580	1.0	1.000
Tin chloride suspension	1580	1.0	1.000

## Table B . : Chemical resistance of Autotex (keypad)

Autotex is resistant (acc. to DIN 42 115, part 2) to following chemicals for a contact time of more than 24 hours without visible modification:

Ethanol Cyclohexanol Diacetone alcohol Glycol Isopropanol Glycerine Methanol Triacetin Dowandol DRM/PM	Formaldehyde 37%-42% Acetaldehyde Aliphatic hydrocarbons Toluol Xylol Diluent (white spirit)	1,1,1-Trichlorethane Ethyl acetate Diethyl ether N-butyl acetate Amyl acetate Butylcellosolve Ether
Acetone Methyl-ethyl-ketone Dioxan Cyclohexanone MIBK Isophorone	Formic acid <50% Acetic acid <50% Phosphoric acid <30% Hydrochloric acid <36% Nitric acid <10% Trichloroacetic acid <50% Sulphuric acid <10%	Chlornatron <20% Hydrogen peroxide<25% Potash soft soap Detergent Tensides Softener Iron chlorides (FeCl <sub>2</sub> ) Iron chlorides (FeCl <sub>3</sub> )
Ammonia <40% Soda lye <40% Potassium hydroxide <30% Alcalicarbonate Bichromate Potassium hexacyanoferrates Acetonitrile Sodium bisulfate	Drilling emulsion Diesel oil Varnish Paraffin oil Castor oil Silicone oil Turpentine oil substitute Dccon	Plane fuel Gasoline Water Salt water Dibutyl Phthalat Diocetyl Phthalat Sodium carbonate

Autotex is resistant (acc. to DIN 42 115, part 2) to acetic acid for a contact time of less than 1 hour without visible damage.

Autotex is not resistant to following chemicals:

Concentrated mineral acids Concentrated alkaline solutions High pressure steam over 100°C	Benzyl alcohol Methylene chloride
---	--------------------------------------



**Table B. : Properties of water with pressure  $P = 1$  bar and saturation**

T (°C)	p (bar)	$\rho$ (kg m <sup>-3</sup> )	$c_p$ (kJ kg <sup>-1</sup> K <sup>-1</sup> )
0	1	999.8	4.218
10	1	999.7	4.192
20	1	998.3	4.182
30	1	995.7	4.178
40	1	992.3	4.178
50	1	988.0	4.181
60	1	983.2	4.184
70	1	977.7	4.190
80	1	971.6	4.196
90	1	965.2	4.205
100	1.013	958.1	4.216
120	1.985	942.9	4.245
140	3.614	925.8	4.285
160	6.181	907.3	4.339
180	10.027	886.9	4.408
200	15.55	864.7	4.497
220	23.20	840.3	4.613
240	33.48	813.6	4.769
260	46.94	784.0	4.983
280	64.20	750.5	5.290
300	85.93	712.2	5.762
320	112.89	666.9	6.565
340	146.05	610.2	8.233
360	186.75	527.5	14.58
374.15	221.20	315.5	$\infty$

T Temperature

P Pressure

$\rho$  Density

$c_p$  Specific heat at constant pressure