

PUMP SERIES 989

User and Maintenance Manual

Warranty information

TABLE OF CONTENTS

1. INTRODUCTION
2. GENERAL DESCRIPTION
3. PRODUCT-MACHINE IDENTIFICATION
4. TECHNICAL SPECIFICATIONS
5. MACHINE COMPONENTS
6. UNPACKING AND INSTALLING THE MACHINE
7. INSTRUCTIONS FOR USE
8. TROUBLESHOOTING
9. MAINTENANCE PROCEDURE
10. DISPOSAL
11. ORDERING INFORMATION
12. DIMENSIONS
13. HANDLING AND TRANSPORTATION
14. OPERATING HAZARDS
15. PRECAUTIONS
16. WARRANTY INFORMATION
17. DECLARATION OF COMPLIANCE WITH STANDARDS
18. DROPSA LOCATIONS

Manufacturer	DropsA SpA
Product	PUMP SERIES 989
Year	2007
Certification	CE

1. INTRODUCTION

This user's and maintenance manual refers to a **989 pump series** for grease.

It is recommended that this manual is carefully kept in good condition and is always available to persons requiring to consult it.

To request further copies, updates or clarifications with respect to this manual contact the Engineering Department at Dropsa SpA.

The use of the pump referred to in this manual must be entrusted to qualified personnel with a knowledge of hydraulics and electrical systems.

The manufacturer reserves the right to update the product and/or the user's manual without the obligation to revise previous versions. It is however, possible to contact the Engineering Department for the latest revision in use.

The pump, and any accessories mounted on it, should be carefully checked immediately on receipt and in the event of any discrepancy or complaint the Dropsa SpA Sales Department should be contacted without delay.

DROPSA S.p.A. declines to accept any responsibility for injuries to persons or damage to property in the event of the non-observance of the information presented in this manual.

Any modification to component parts of the system or the different destination of use of this system or its parts without prior written authorization from DROPSA S.p.A. will absolve the latter from any responsibility for injury or damage to persons and/or property and will release them from all obligations arising from the guarantee.

2. GENERAL DESCRIPTION

The features which distinguish this pump are:

high performance,
simplicity of construction,
modularity,

The simplicity of construction guarantees long life, reliability and simplified and reduced maintenance. The modularity of the components allows the system engineer to construct the lubrication unit to meet the specific needs of the lubrication system it is serving.

3. PRODUCT MACHINE IDENTIFICATION

Machine identification yellow label is located on the front side of the reservoir and contains product serial number, input voltage and details of the operating parameters.

4. TECHNICAL SPECIFICATIONS

TECHNICAL CHARACTERISTICS	
Pressure	300 Bar (4410 psi)
Fixed delivery max (pumping Ø6 mm)	10 cm ³ / min (0.55 cu. in/min)
Fixed delivery max (pumping Ø8 mm)	17 cm ³ / min (1.03 cu. in/min)
Adjustable delivery max (pumping Ø6 mm)	1,4-10 cm ³ / min (0.085 - 0.61 cu. in/min)
Adjustable delivery max (pumping Ø6 mm)	2,5-17 cm ³ / min (0.15 - 1.03 cu. in/min)
No. pumpings	1 ÷ 3
Capacity reservoir	5 kg. (11 lb)
Lubricant	Grease
Lubricant Viscosity	000 ÷ 2 NLGI
Working Temperature	+ 10° C ÷ + 40° C (+50° ÷ +104° F)
Motor Voltage	220/380 V – 50/60 Hz
Power absorption	90 W

5. MACHINE COMPONENTS



5.1 Minimum level indicator

Electro-mechanical type

Normally closed at minimum level. Maximum commutable power ISA; maximum commutable voltage 220/240 VAC.

5.2 Pressure gauge (Accessory)

Part No.	PRESSURE RANGE
3292099	0 ÷ 400 Bar (0 ÷ 40 Mpa)

5.3 BY-PASS VALVE (Accessory)

Part No.	PRESSURE RANGE
888036	0 ÷ 250 bar (0 ÷ 3675 psi).

It is possible to adjust working pressure by means of a by pass valve installed on delivery line. The use of the by pass valve it's recommended to control the pump operating and to avoid over pressure in the circuit.

5.4 Filling filter

This removable cartridge filter is recommended to ensure the filling of lubricant which is free from foreign bodies and to avoid the formation of air bubbles. Type of lubricant: Grease NLGI 2

5.5 Pumping unit

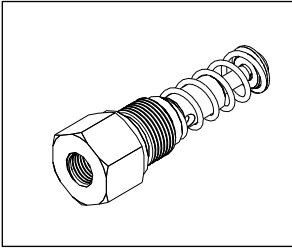

Representing the pump operating-member, it is screwed directly into pump housing and driven by means of an eccentric cam. The suction system consists of a free-dual-line, while discharge is provided with an adjustable delivery valve

Its components are made of high-quality alloy steel, specially treated to improve wear-resistance characteristics. Furthermore, a special external coating guarantees excellent resistance to corrosion, tested through salt fog tests.

5.6 Auxiliary pumping unit

989 pump series are supplied with a pumping unit but it is possible to install one or two auxiliary pumpings (with fixed or adjustable delivery). Combining the three pump elements for higher output or manage up to three lubrication lines.

6. UNPACKING AND INSTALLING THE PUMP

6.1 Unpacking

Once a suitable location has been found to install the unit remove the pump from the packaging. Check the pump has not been damaged during transportation or storage. No particular disposal procedures are necessary, however packing should be disposed of in accordance with regulations that may be in force in your area or state.

6.2 Installing the pump

Damage to the power supply cable and housing could result in contact with high voltage (220/380 VAC) live parts and hence be a danger to life:

- Mount the pump in a way that the refill lubricator and timer are always easy to access;
- Carefully check the integrity of the power supply cable and the unit before use;
- In the event of there being damage to the power supply cable or the unit, **DO NOT** put the system into service!;
- Replace the damaged power supply cable with a new one;
- The unit can be opened and repaired **ONLY** by qualified personnel;
- In order to prevent dangers of electric shock due to direct or indirect contact with live parts it is necessary that the electrical power supply line is adequately protected by a suitable differential magneto-thermal circuit breaker with an intervention threshold of 0.03 Ampere and a max. operating time of 1 second.



The breaking capacity of the circuit breaker must be ≤ 10 kA and the nominal current $I_n = 4$ A

- The connection of the pressure switch mounted directly on the tank must be 240 VAC/DC.
- The pump **MUST NOT** be submersed in fluids or utilized in environments which are particularly aggressive or explosive/inflammable if not prepared for this purpose beforehand by the supplier.
- For correct fixing verify the distance between centers.
- Use gloves and safety glasses as required in the lubrication oil safety chart;
- **DO NOT** use aggressive lubricants with NBR gaskets and seals; if in doubt consult the Engineering Department of Dropsa SpA, who will provide a chart with the details of recommended oils;
- **DO NOT** ignore dangers to health and observe all hygiene standards;
- **WARNING!** All electrical components must be grounded. This refers to both electrical components and control devices. In this regard ensure that the ground cable is correctly connected. For reasons of safety the ground cable must be approx. 100 mm longer than the phase cables. In the event of accidental detachment of the cable, the ground terminal must be the last to be removed.

Action to be taken prior to start up

- Verify the integrity of the pump;
- Fill the tank with suitable lubricant (min/max indication on the tank);
- Verify that the pump is at operating temperature and the tubing free from air bubbles;
- Check that the electrical connections have been effected correctly (UNI 64/8, IEC ...);

 **The minimum level indicator is supplied, unless otherwise specified by the customer, with the contact closed for minimum level. Should the user require to use a normally open contact it will be necessary to invert the operating direction of the microswitch.**

7. INSTRUCTIONS FOR USE

1. Verify the settings made;
2. Press the start button of the machine to which the 989 series pump is connected;
3. Verify the starting of the pump;
4. Verify the adequate lubrication of the machine (if doubt exists as to the correct functioning consult the Engineering Department of Dropsa SpA to request test procedures).
5. Reservoir is refilled through lubricator "A".

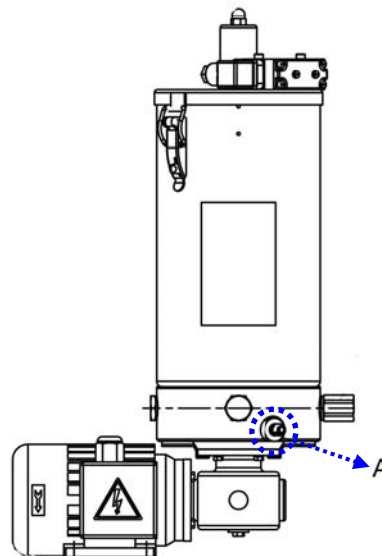

8. TROUBLESHOOTING

The following diagnostic table indicates the main anomalies which may be encountered, the probable causes and possible solutions. **If you cannot solve the problem, do not attempt to disassemble the unit, but contact the Engineering Department of DROPSA S.p.A.**

N	ANOMALY	CAUSE	REMEDY
01	Motor does not operate	Power supply failure	Verify power supply system, and check the fuse
		Ratiomotor does not operate	Replace the ratiomotor
02	Pump does not deliver lubricant	Reservoir is empty	Refill the tank with clean lubricant,
		Air-bubbles in lubricant	Disconnect main piping from pumping element fitting. Operate the pump in the manual mode until lubricant free of air-bubbles comes out of the fittings
		Obstructed suction pipe-line	Disassemble the pumping unit and clear the suction pipe-line
03	Pump operates but does not deliver lubricant to the bearing- points	Disconnected piping	Inspect piping and replace the wear pipes
		Blocked progressive distributor	Clear the distributor. Replace it, if necessary

N	ANOMALY	CAUSE	REMEDY
04	Lubricant reaches the bearing-points in incorrect quantities	The distributor is not correctly connected to the bearing-points.	Verify that the dosages are those indicated in the system diagram
		Delivery is not correct (only for adjustable delivery pump unit).	Adjust delivery by means of regulation screw
05	Pump starts lubricating but stops immediately	Faulty motor or high output consumption.	Allow the pump being cooled for a few minutes and try again. If the problem still continues, contact the Customer Service
06	Irregular flow rate	Screw C, which secures the pump element D and return spring E, is loose (only for adjustable delivery pump unit).	Remove the pump element assembly from the pump body and completely disassemble it. To reassemble the pump element assembly see the sequence in the diagram. Check and clean all pump unit parts. Verify the component integrity. Warning: put some Loctite type sealant on screw C, which is inserted into pump element D. Hold the pump element between wooden vice clamps to prevent damage to the lapped surface. Lock up very well the element B.
07	The system doesn't reach the pressure	Delivery valve dirty. Delivery valve damaged.	Dismount the valve A, clean it and mount following the showed sequence.
		Spring broken	Replace the pumping unit.

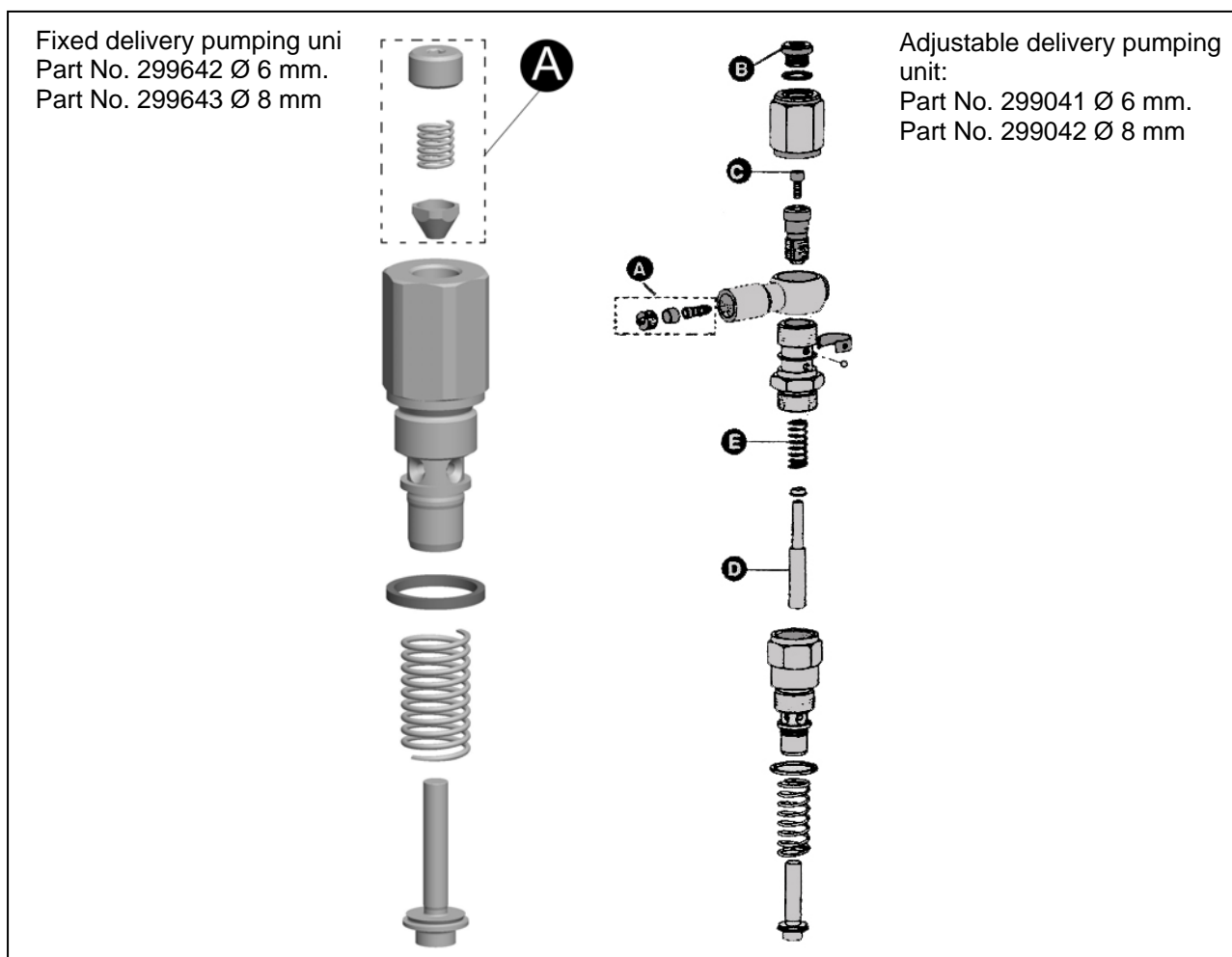

WARNING: Prior to any maintenance, be sure that the power and the hydraulic supplies are off and there is no residual pressure in the main/branch pipe.

9. MAINTENANCE PROCEDURE

Position the machine in such a way that it can be checked easily.
Wear the correct individual protection gear in order to avoid contact with the mineral oil.

It is necessary to periodically check as follows:

VERIFICATION	WORK CYCLE/RUNNING TIME
The state of lubrication	1000/every 6 months
The oil/grease level	2000/once a year
Cleanliness of the filling and intake filter (where fitted)	500/every 6 months

The machine does not require special equipment for any inspection and/or maintenance activity. It is however recommended that the equipment used be suitable and in good condition (DPR 547/55) so as to avoid damage to people or parts of the machine.

9.1 Assembly/Disassembly

No pump assembly operations are envisaged.

For wall mounting ensure adequate space is available (as shown in the installation diagram) to avoid abnormal postures and possible impacts; four fixing holes are provided for wall mounting and three for base fitting.

Subsequently it will be necessary, as previously described, to connect the pump to the machine hydraulically and then to connect the control panel.

During the disassembly phase ensure the tank is empty.

Disconnect the electrical and hydraulic parts.

Where the machine is to be scrapped, do not dispose of potentially polluting parts in the environment, following local regulations for their correct disposal.

At the time of the machine being scrapped it is necessary to remove and destroy the identification plate and all other relative documents.

9.2 Regulation

Flow rate (for versions with adjustable flow rates)

It is possible to regulate the flow rate by rotating the regulating screw (8 mm hexagonal key) clockwise to decrease and anticlockwise to increase (remove the cap B).

9.3 Repairs

The following diagnostic table indicates the main anomalies which may be encountered, the probable causes and possible solutions.

The anomalies shown are:

- the pump fails to deliver lubricant
- irregular pressure
- irregular flow rate

In case of doubts and/or problems which cannot be resolved do not attempt to disassemble parts of the machine but contact the Engineering Department of DROPSA S.p.A.

10. DISPOSAL

During maintenance or disposal of the machine care should be taken to properly dispose of environmentally sensitive items such as oils or other lubricants. Refer to local regulations in force in your area. When disposing of this unit, it is important to ensure that the identification label and all the other relative documents are also destroyed.

11. ORDERING INFORMATION

11.1 FIXED DELIVERY

	Part No.	Description
220/380 V 50/60 Hz	989001	Grease Electro-pump 1 pumping unit Ø 6 mm
	989002	Grease Electro-pump 1 pumping unit Ø 8 mm
24 V DC*	989011	Grease Electro-pump 1 pumping unit Ø 6 mm
	989012	Grease Electro-pump 1 pumping unit Ø 8 mm

(*) For 24V version the motor is supplied with 1 mt (3.28 ft) without terminal

ADJUSTABLE DELIVERY

	Part No.	Description
220/380 V 50/60 Hz	989003	Grease Electro-pump 1 pumping unit Ø 6 mm
	989004	Grease Electro-pump 1 pumping unit Ø 8 mm
24 V DC*	989013	Grease Electro-pump 1 pumping unit Ø 6 mm
	989014	Grease Electro-pump 1 pumping unit Ø 8 mm

(*) For 24V version the motor is supplied with 1 mt (3.28 ft) without terminal

11.2 ACCESSORIES

Part No.	DESCRIPTION
299642C	Pumping unit Ø 6 mm - Fixed delivery 10 cm ³ /min (0.61 cu. in/min)
299643C	Pumping unit Ø 8 mm - Fixed delivery 17 cm ³ /min (1.03 cu. in/min)
299041C	Pumping unit Ø 6 mm - Adjustable delivery 1,4-10 cm ³ /min (0.085 - 0.61 cu. in/min)
299042C	Pumping unit Ø 8 mm - Adjustable delivery 2,5-17 cm ³ /min (0.15 - 1.03 cu. in/min)
888036	By Pass 0-250 Bar
3292099	Pressure gauge 0-400 Bar

11.3 SPARE PARTS

Part No.	DESCRIPTION
3301504	Motor GR 56 KW 0,09 220/380 V 50/60 Hz
712100	Filter 220 µ
3301505	Reduction gear R 1:30

12. DIMENSIONS

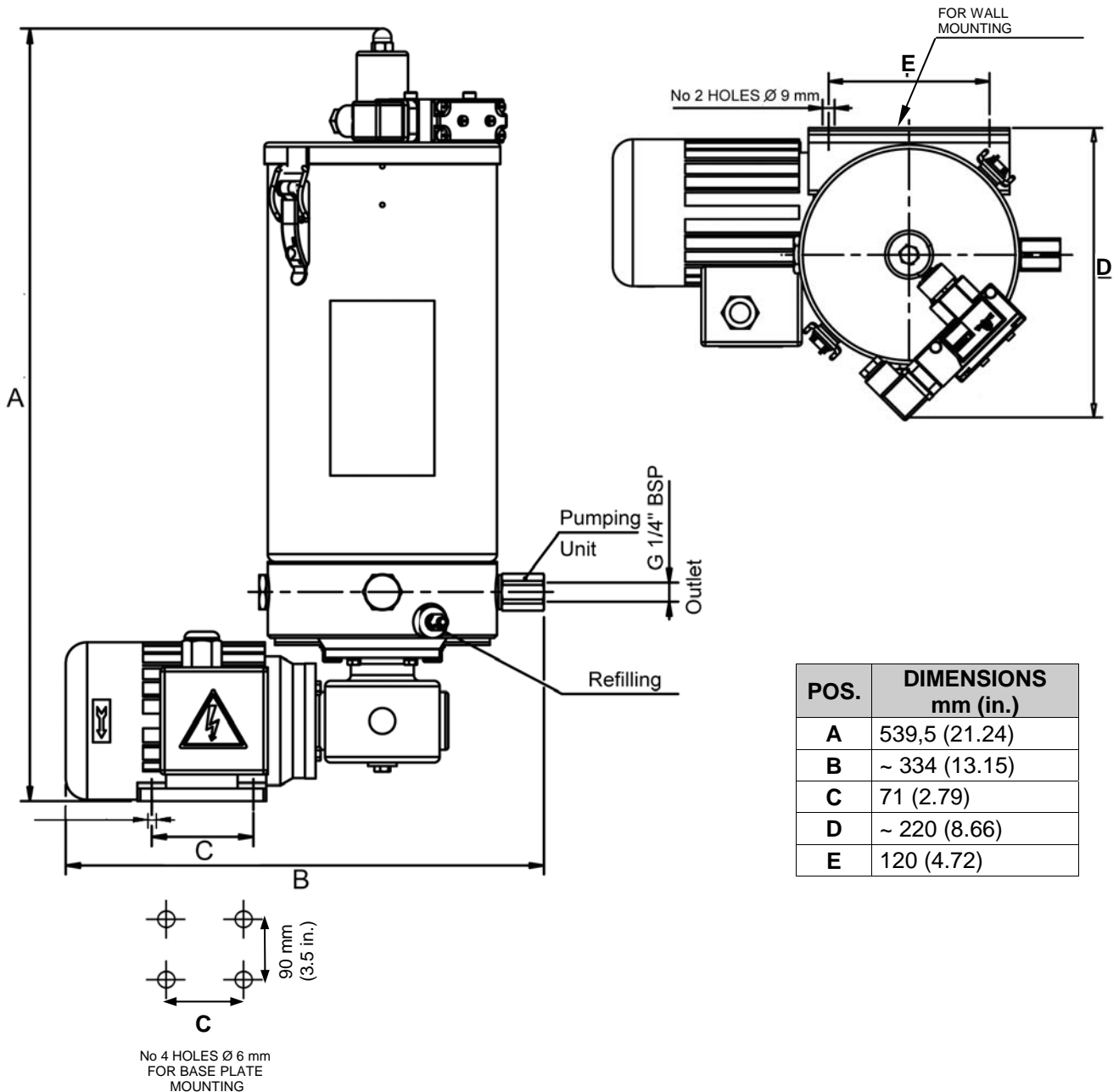

13. HANDLING AND TRANSPORTATION

Prior to shipping, the equipment is carefully packed in cardboard package. During transportation and storage, always maintain the pump the right way up as indicated on the box. On receipt check that package has not been damaged. Then, storage the machine in a dry location.

No particular precautions are required except as noted on the package itself.

Handling must be effected by at least two persons.

- ! Lift the unit with taking account of the right way up indicated on the cardboard carton
- ! The machine components can withstand temperatures, during storage, from -20 to $+50^{\circ}\text{C}$; however, in order to avoid damage, starting of the machine should occur at a minimum temperature of -5°C .

14. OPERATING HAZARDS



WARNING: *It is necessary to carefully read about the instructions and the risks involved in the use of lubrication machines. The operator must know the machine functioning through the User and Maintenance Manual.*

Power supply

Any type of intervention must not be carried out before unplugging the machine from power supply. Make sure that no one can start it up again during the intervention.

All the installed electric and electronic equipment, reservoirs and basic components must be grounded.

Flammability

The lubricant generally used in lubrication systems is not normally flammable. However, it is advised to avoid contact with extremely hot substances or naked flames.

Pressure

Prior to any intervention, check the absence of residual pressure in any branch of the lubricant circuit as it may cause oil sprays when disassembling components or fittings.

Noise

Pump does not produce excessive noise, less than 70 dB(A) .

15. PRECAUTIONS

The verification of conformity with the essential safety requirements and regulations of the Machine Directive is effected by means of the compilation of a check list which has been pre-prepared and is contained in the *technical file*.

The lists which are utilised are of three types:

- list of dangers (as in EN 414 referring to EN 292)
- application of essential safety requirements (Machine Dir. - att. 1, part 1)
- electrical safety requirements (EN 60204-1).

The following is a list of dangers which have not been fully eliminated but which are considered acceptable:

- in the version of the pump without a release it is possible to encounter squirts of oil (for this reason appropriate protective clothing must be worn)
- contact with oil -> see the requirements for the use of suitable personal protective clothing
- use of unsuitable lubricant -> the characteristics of the fluid are shown on the pump and in the manual (**in case of doubt contact the Eng. Dept of Dropsa Spa**)
- protection against direct and indirect contact must be provided by the user
- given the purpose of the pump it must always be functioning; for this reason it is necessary to pay attention to the electrical connections which, in the case of a power failure, the customer's machine is restarted only by means of a reset, while the lubrication pump is able to restart automatically.
- incorrect assembly of the regulator (valve) can result in an over pressure which can prejudice the functioning of the pump itself and create danger for the user. This is avoided by stamping the mounting instructions on the table.

Fluid	Danger
Lubricants with abrasive additives	High wear rate of contacted parts
Lubricants with silicone based additives	Seizure of the pump
Petrol – solvents – inflammable liquids	Fire – explosion – damage to seals
Corrosive products	Corrosion of the pump– injury to persons
Water	Oxidation of the pump
Food substances	Contamination of the substances themselves

16. WARRANTY INFORMATION

All products manufactured and marketed by Dropsa are warranted to be free of defects in material or workmanship for a period of at least 12 months from date of delivery. Extended warranty coverage applies as follows:

Complete system installation by Dropsa: 24 Months

All other components: 12 months from date of installation; if installed 6 months or more after ship date, warranty shall be maximum of 18 months from ship date.

If a fault develops, notify us giving a complete description of the alleged malfunction. Include the part number(s), test record number where available (format xxxxxx-xxxxxx), date of delivery and installation and operating conditions of subject product(s). We will subsequently review this information and, at our option, supply you with either servicing data or shipping instruction and returned materials authorization (RMA) which will have instructions on how to prepare the product for return. Upon prepaid receipt of subject product to an authorized Dropsa Sales & Service location, we will then either repair or replace such product(s), at our option, and if determined to be a warranted defect, we will perform such necessary product repairs or replace such product(s) at our expense.

Dropsa reserves the right to charge an administration fee if the product(s) returned are found to be not defective.

This limited warranty does not cover any products, damages or injuries resulting from misuse, neglect, normal expected wear, chemically caused corrosion, improper installation or operation contrary to factory recommendation. Nor does it cover equipment that has been modified, tampered with or altered without authorization.

Consumables and perishable products are excluded from this or any other warranty.

No other extended liabilities are stated or implied and this warranty in no event covers incidental or consequential damages, injuries or costs resulting from any such defective product(s).

The use of Dropsa product(s) implies the acceptance of our warranty conditions. Modifications to our standard warranty must be in writing and approved by Dropsa.

17. DECLARATION OF COMPLIANCE WITH CE STANDARDS

Dropsa

Dropsa Spa
Via B. Croce, 1
20090 – VIMODRONE (MI)
ITALY

Tel.: (+39) 02-250.79.1
Fax Sales.: (+39) 02-250.79.767
Fax Purch.: (+39) 02-250.79.320
E-mail: sales@dropsa.it



Centralized Lubrication Engineers and Component Manufacturers
Gli Specialisti Della Lubrificazione Dal 1946

DICHIARAZIONE **CE** DI CONFORMITÀ Allegato II A, della Direttiva 98/37/CE

La Sottoscritta Milena Gavazzi, in qualità di legale rappresentante del fabbricante della Società Dropsa S.p.A., con sede legale in Milano, Via Visconti di Modrone, 2.

DICHIARA, sotto la propria esclusiva responsabilità,

• che le macchine denominate :
989001, 989002, 989003, 989004.
sono conformi alle condizioni previste dalle Direttive:

- 98/37 CE Direttiva Macchine
- 73/23 CEE, Direttiva bassa tensione
- 89/336 CEE, Direttiva compatibilità elettromagnetica

poiché rispetta tutti i requisiti essenziali di sicurezza e sanitari che le concernono, ed in riferimento alle seguenti norme armonizzate:

- EN 12100-1/2 Sicurezza del macchinario – concetti fondamentali/principi di progettazione.
- EN 1050 Sicurezza del macchinario – principi per la valutazione del rischio.
- EN 982 Sicurezza del macchinario. Requisiti di sicurezza relativi a sistemi e loro componenti per trasmissioni oleoidrauliche e pneumatiche. Oleoidraulica.
- EN 11200 Rumore emesso dalle macchine e dalle apparecchiature.
- EN 894-1/2/3 Requisiti ergonomici per la progettazione dei dispositivi di informazione e di comando.
- EN 60204-1 Sicurezza del macchinario. Equipaggiamento elettrico delle macchine

Vimodrone (MI), 15/01/07

Il legale rappresentante

Modello dichiarazione CEE conforme a quanto previsto dalla norma EN 45014

18. DISTRIBUTORS



Dropsa USA Inc.
50679 Wing Drive
Utica, Michigan 48315, USA
Tel: (+1) 586-566-1540
Fax: (+1) 586-566-1541
E-mail: salesusa@dropsa.com



Dropsa (UK) Ltd
Unit 6, Egham Business Village,
Egham, Surrey, TW20 8RB
Tel: (+44) 01784 - 431177
Fax: (+44) 01784 - 438598
E-mail: salesuk@dropsa.com



Dropsa S.p.A.
Via B. Croce, 1
20090 Vimodrone (MI) Italy.
Tel: (+39) 02 - 250.79.1
Fax: (+39) 02 - 250.79.767
E-mail: sales@dropsa.it (Export)
E-mail: vendite@dropsa.it (National)



Dropsa GmbH
Volmerswerther Strasse 80
40221 Dusseldorf 1, Germany
Tel: (+49) 0211/39 40 11
Fax: (+49) 0211/39 40 13
E-mail: sales@dropsa.de



Dropsa France
23, Av.des.Morillons
Z.I. des Doucettes
91140 - Garges Les Gonesse
Tel: (+33) 01 39 93 00 33
Fax: (+33) 01 39 86 26 36
E-mail: sales@dropsa.com



Dropsa do Brazil
Rua Sobralia 171 Santo Amaro
Sao Paulo, Brazil
Tel: (+55) 011-5631-0007
Fax: (+55) 011-5631-9408
E-mail: salesbr@dropsa.com



Polydrop S.A.
Av. Fabregada 26 - Pje Est.2
08907 L'Hospitalet de Llobregat
Barcelona, Spain
Tel: (+34) 93 260 22 50
Fax: (+34) 93 260 22 51
E-mail: sales@dropsa.it



Dropsa Australia Pty.
C20/148 Old Pittwater Road
Brookvale NSW 2100
Tel: (+61) 299 386 644
Fax: (+61) 299 386 611
E-mail: sales@dropsa.com



Web site: <http://www.dropsa.com> - **E-mail:** sales@dropsa.com