

# **SPACAR User Manual**

dr. ir. R. G. K. M. Aarts, dr. ir. J. P. Meijaard and prof. dr. ir. J. B. Jonker

2008 Edition, March 20, 2008

Report No. WA-1138



# Table of contents

<b>Preface</b>	<b>iii</b>
<b>1 The SPACAR program</b>	<b>1</b>
1.1 Introduction . . . . .	1
1.2 SPACAR & MATLAB . . . . .	1
1.3 SPAVISUAL . . . . .	9
1.4 SPASIM and SIMULINK . . . . .	9
1.5 Perturbation method and modal techniques . . . . .	11
<b>2 Keywords</b>	<b>15</b>
2.1 Introduction . . . . .	15
2.2 Kinematics . . . . .	16
2.3 Dynamics . . . . .	23
2.4 Inverse dynamics (setpoint generation) . . . . .	29
2.4.1 Trajectory generation . . . . .	29
2.4.2 Nominal inputs and reference outputs . . . . .	34
2.5 Linearization . . . . .	36
2.6 Non-linear simulation of manipulator control . . . . .	40
2.7 Visualization and animation . . . . .	42
<b>3 Examples</b>	<b>45</b>
3.1 Planar sliding bar . . . . .	45
3.2 Planar slider–crank mechanism . . . . .	47
3.3 Cardan-joint mechanism . . . . .	55
3.4 Planar four-bar mechanism . . . . .	58
3.5 Rotating mass–spring system . . . . .	61
3.6 Cantilever beam in Euler buckling . . . . .	64
3.7 Cantilever beam subject to concentrated end force . . . . .	66
3.8 Short beam . . . . .	69
3.9 Lateral buckling of cantilever beam . . . . .	71
3.10 State-variable and output equations . . . . .	74

3.11 Rigid spatial manipulator mechanism . . . . .	77
3.12 Flexible spatial manipulator mechanism . . . . .	87
<b>A SPACAR installation</b>	<b>89</b>
<b>B SPACAR error messages</b>	<b>91</b>
<b>C MATLAB tutorial</b>	<b>93</b>
C.1 Basic MATLAB graphics commands . . . . .	93
C.2 Quitting and saving the workspace . . . . .	95
<b>References</b>	<b>97</b>

# Preface

This is the 2008 edition of the manual that describes the use of the SPACAR-package in a MATLAB/SIMULINK environment. This software is being developed at the Laboratory of Mechanical Automation of the Department of Engineering Technology, University of Twente, and is partly based on work carried out at the Department of Engineering Mechanics, Delft University of Technology.

This manual accompanies the 2008 UT-release of SPACAR. With respect to the previous editions of this manual new keywords have been included reflecting changes in the software. Furthermore, the specification of element stiffnesses and damping has been changed, which makes old input files for flexible systems incompatible. As before, the SPAVISUAL manual is now integrated. The examples are updated to show the use of SPAVISUAL.

The references to sections and examples in the lecture notes [1] are updated for the 2005 edition of these lecture notes. They may be only approximate for other editions.

The visualisation tool SPAVISUAL has been implemented by Jan Bennik, who also provided the description of the keywords and the examples for the part of the manual related to this tool.

Corrections of errors, suggestions for improvements and other comments are welcome.

March 20, 2008, dr. ir. R. G. K. M. Aarts (Email: [R.G.K.M.Aarts@utwente.nl](mailto:R.G.K.M.Aarts@utwente.nl)), dr. ir. J. P. Meijaard and prof. dr. ir. J. B. Jonker.



# The SPACAR program

## 1.1 Introduction

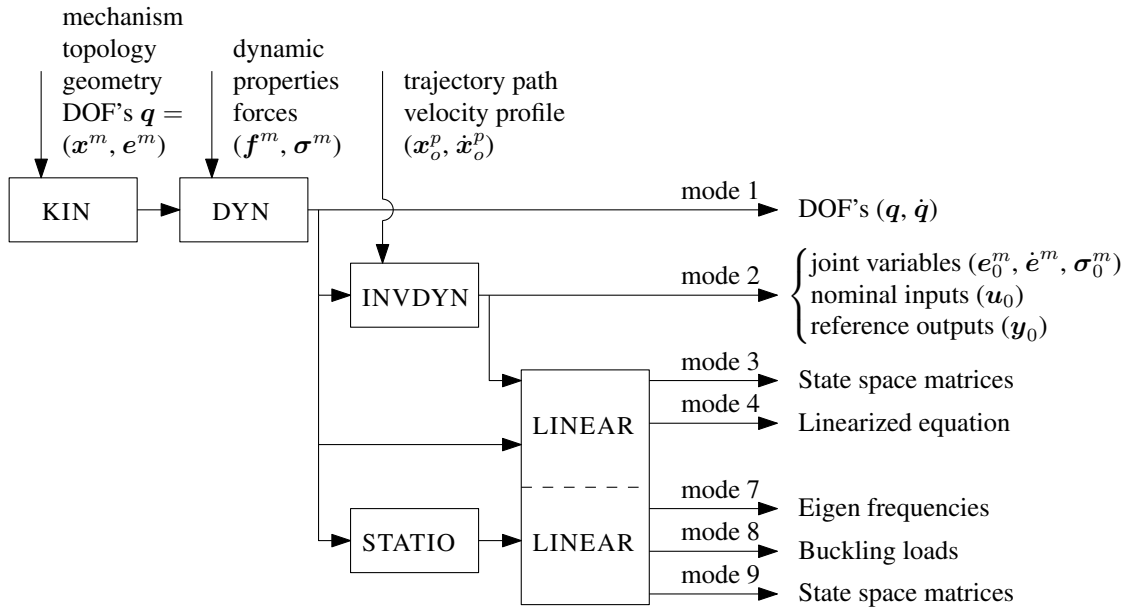
The computer program SPACAR is based on the non-linear finite element theory for multi-degree of freedom mechanisms as described in Jonker's lecture notes on the Dynamics of Machines and Mechanisms [1]. The program is capable of analysing the dynamics of planar and spatial mechanisms and manipulators with flexible links and treats the general case of coupled large displacement motion and small elastic deformation. The motion can be simulated by solving the complete set of non-linear equations of motion or by using the so-called perturbation method. The computational efficiency of the latter method can be improved further by applying modal techniques.

In this chapter an outline of the SPACAR package for use with MATLAB and SIMULINK is given in the next sections. E.g. for the design mechanical systems involving automatic controls (like robotic manipulators) interfaces with MATLAB [2] are provided for open-loop system analyses, Section 1.2. Open-loop and closed-loop simulations can be carried out with blocks from a SIMULINK library, Section 1.4. A special visualization tool, SPAVISUAL, is described in Section 1.3. Additional tools are available for using the perturbation method and the modal techniques in SIMULINK (Section 1.5). Installation notes for SPACAR are given in Appendix A.

A graphical user interface (GUI) for generating input files for spatial systems is in preparation and, as we hope, will be available in near future. People interested in rigid planar mechanisms may consider the use of the commercially available package SAM by ARTAS [4]. It has a nice graphical interface for the definition of mechanisms and it provides more elements than SPACAR.

## 1.2 SPACAR & MATLAB

The SPACAR program system for use in the MATLAB environment contains five modules, which obtain their input from format free user supplied data. In the following a short description of every module will be given. The functional connections between the modules are illustrated in Fig. 1.1.



**Figure 1.1.** Functional relations between modules in SPACAR. The indicated modes are available in the MATLAB environment.

**KIN** is the kinematics module that analyses the geometry of the mechanism. The kinematic properties of the motion are specified by the geometric transfer functions. The following steps are provided by the KIN-module:

1. Definition of the mechanism topology, the geometry and the degrees of freedom (DOFs),  $\mathbf{q} = (\mathbf{x}^{(m)}, \mathbf{e}^{(m)})$ .
2. System preparation.
3. Calculation of the geometric transfer functions.

**DYN** is the dynamics module that generates the equations of motion and performs numerical integration in the forward dynamic analysis (in the so-called mode=1 of SPACAR). Furthermore, it generates and solves the equations for the kinetostatic analysis.

**INV DYN** is the inverse manipulator dynamics module that performs the inverse kinematics and dynamics (mode=2) and generates the setpoints for the simulation of manipulator motion with closed-loop control in SIMULINK (see Sect. 1.4). The system inputs, represented by the nominal input vector  $\mathbf{u}_0$ , are to be varied by the control system actuators. The system outputs, represented by the reference output vector  $\mathbf{y}_0$ , consist of the coordinates to be monitored by control sensors. Coordinates that are not measured may be added to check the performance of the manipulator in the simulation.

**STATIO** computes stationary solutions of autonomous systems. Stationary solutions are solutions in which the vector of dynamic degrees of freedom  $\mathbf{q}^d$  has a constant value. This can represent a static equilibrium configuration or a state of steady motion.

**LINEAR** is a forward dynamics stage for the generation of linearized equations and state space matrices. It can be used in different modes as described below.



In mode=4 the LINEAR module is an extension of the forward dynamic analysis (mode=1) where coefficient matrices of the linearized equations are calculated as functions of the set of degrees of freedom  $\mathbf{q}$ . The linearized equations are generated in the form:

$$\bar{\mathbf{M}}_0 \delta \ddot{\mathbf{q}} + [\mathbf{C}_0 + \mathbf{D}_0] \delta \dot{\mathbf{q}} + [\mathbf{K}_0 + \mathbf{N}_0 + \mathbf{G}_0] \delta \mathbf{q} = \mathbf{D}\mathcal{F}_0^{(x)T} \delta \mathbf{f} - \mathbf{D}\mathcal{F}_0^{(e)T} \delta \boldsymbol{\sigma}_a, \quad (1.1)$$

where  $\bar{\mathbf{M}}_0$  is the reduced mass matrix,  $\mathbf{C}_0$  the velocity sensitivity matrix,  $\mathbf{D}_0$  the damping matrix,  $\mathbf{K}_0$  denotes the structural stiffness matrix,  $\mathbf{N}_0$  and  $\mathbf{G}_0$  are the dynamic and geometric stiffness matrices respectively. External and internal driving forces are represented by the vectors  $\delta \mathbf{f}$  and  $\delta \boldsymbol{\sigma}_a$ , respectively. In addition, if input and output vectors  $\delta \mathbf{u}$  and  $\delta \mathbf{y}$  are defined also the linearized state equations and output equations are computed (see mode 9).

In mode=3 locally linearized models are generated about a predefined nominal trajectory where the output data (setpoints) from the inverse dynamics module (i.e. a previous mode=2 run) are used. In addition to the coefficient matrices, a complete state space system is generated and written to a so-called `ltv` file (see Sect. 1.5). In the case of a flexible mechanism additional degrees of freedom describing the elastic behaviour of the mechanism have to be included in the dynamic models (both mode=2 and 3). At this stage in the so-called ‘‘rigidified’’ model, these flexibilities are prescribed zero, i.e.  $\varepsilon_i^m \equiv 0$ .

In mode=7 eigenvalues (frequencies) and corresponding eigenvectors of the state space matrix  $\mathbf{A}$  are computed for a static equilibrium configuration or a state of steady motion. The associated frequency equation of the undamped system is given by

$$\det \left( -\omega_i^2 \bar{\mathbf{M}}_0^{dd} + \mathbf{K}_0^{dd} + \mathbf{N}_0^{dd} + \mathbf{G}_0^{dd} \right) = 0, \quad (1.2)$$

where the quantities  $\omega_i$  are the natural frequencies of the system.

In mode=8 a linear buckling analysis is carried out for a static equilibrium configuration or a state of steady motion. Critical load parameters  $\lambda_i$  are determined by solving the eigenvalue problem:

$$\det(\mathbf{K}_0^{dd} + \lambda_i \mathbf{G}_0^{dd}) = 0, \quad (1.3)$$

where,

$$\lambda_i = \mathbf{f}_i / \mathbf{f}_0. \quad (1.4)$$

Here,  $\mathbf{K}_0^{dd}$  is the structural stiffness matrix and  $\mathbf{G}_0^{dd}$  is the geometric stiffness matrix due to the reference load  $\mathbf{f}_0$  giving rise to the reference stresses  $\boldsymbol{\sigma}_0$ .  $\mathbf{f}_i$  represents the buckling load that corresponds with  $\lambda_i$ . In addition directional nodal compliances are computed.

In mode=9 linearized equations for control system analysis are computed for a static equilibrium configuration or a state of steady motion and are generated in the form:

$$\bar{\mathbf{M}}_0^{dd} \delta \ddot{\mathbf{q}}^d + [\mathbf{C}_0^{dd} + \mathbf{D}_0^{dd}] \delta \dot{\mathbf{q}}^d + [\mathbf{K}_0^{dd} + \mathbf{N}_0^{dd} + \mathbf{G}_0^{dd}] \delta \mathbf{q}^d = \mathbf{B}_0 \delta \mathbf{u}, \quad (1.5)$$

where

$$\mathbf{B}_0 = \left[ \mathbf{D}_{q^d} \mathcal{F}_0^{(x)T} \mid -\mathbf{D}_{q^d} \mathcal{F}_0^{(e)T} \mid -\bar{\mathbf{M}}_0^{dr} \mid -(\mathbf{C}_0^{dr} + \mathbf{D}_0^{dr}) \mid -(\mathbf{K}_0^{dr} + \mathbf{N}_0^{dr} + \mathbf{G}_0^{dr}) \right] \quad (1.6)$$

is the input matrix and

$$\delta \mathbf{u} = \left[ \delta \mathbf{f}^{(m)T}, \delta \boldsymbol{\sigma}_a^{(m)T}, \delta \ddot{\mathbf{q}}^{rT}, \delta \dot{\mathbf{q}}^{rT}, \delta \mathbf{q}^{rT} \right]^T \quad (1.7)$$

is the input vector. The vectors  $\delta\ddot{\mathbf{q}}^{rT}$ ,  $\delta\dot{\mathbf{q}}^{rT}$ ,  $\delta\mathbf{q}^{rT}$  represent the prescribed (input) accelerations, velocities and displacements respectively. The linearized equations can be transformed into the linearized state space form:

$$\begin{aligned}\delta\dot{\mathbf{z}} &= \mathbf{A}\delta\mathbf{z} + \mathbf{B}\delta\mathbf{u}, \\ \delta\mathbf{y} &= \mathbf{C}\delta\mathbf{z} + \mathbf{D}\delta\mathbf{u},\end{aligned}\tag{1.8}$$

where  $\mathbf{A}$  is the state matrix,  $\mathbf{B}$  the input matrix,  $\mathbf{C}$  the output matrix and  $\mathbf{D}$  the feed through matrix. The state vector  $\delta\mathbf{z}$  is defined by  $\delta\mathbf{z} = [\delta\mathbf{q}^{dT}, \delta\dot{\mathbf{q}}^{dT}]^T$ , where  $\delta\mathbf{q}^d$  is the vector of dynamic degrees of freedom. The matrices  $\mathbf{B}$ ,  $\mathbf{C}$  and  $\mathbf{D}$  depend on the chosen input vector  $\delta\mathbf{u}$  and the output vector  $\delta\mathbf{y}$ . Details of the linearization are discussed in Chapter 12 of the lecture notes.

## Definition of a mechanism model

A model of a mechanism must be defined in an input file of file type (or file name extension) `.dat`. This input file consists of a number of keywords with essential and optional parameters. The input file can be generated with any text editor.

In Chapter 2 the meaning of the keywords and their parameters is discussed in detail. In the examples in Chapter 3 complete input files are presented.

## Running SPACAR in the MATLAB environment

Once the mechanism is defined and this information is saved to a `.dat` input file, SPACAR can be activated with the MATLAB command

```
>> spacar(mode, 'filename')
```

Here, `mode` indicates the type of computation as shown in Fig. 1.1. `filename` is the name of the input file, without the extension `.dat`. The `filename` is limited to 20 characters from the set “0”–“9”, “a”–“z”, “A”–“Z” and “\_”, so it can not include drive or path specifications. The linearization with `mode=3` needs data from a previous inverse dynamics computation. To that order the specified `filename` is truncated with at least one character at the right until a valid output data file is found. So e.g. `spacar(3, 'testlin')` can use data from an earlier `spacar(2, 'test')` computation. If no data file can be found this way the linearization is aborted.

During the computation a plot of the mechanism is shown in a separate window. While the simulation is running an `Abort` button is activated in the plot area. Pressing this button will terminate the simulation (possibly after some delay). To speed up the computation, the plot can be disabled by specifying the mode with a minus sign, e.g. `mode=-2` for an inverse dynamics computation without a continuously updated plot. The plotting utility `spadraw` can also be used after the simulation to visualize the results, see page 8.

During the computations the results are stored in one or more data files and in MATLAB arrays. A `log` file is always created when SPACAR starts processing the input `.dat` file. This `log` file contains an analysis of the input and possible errors and warnings. It is described in more detail on page 7. Some errors in the input file do not lead to an early termination of the SPACAR computation, but nevertheless give unusable results. Therefore it is advisable to check the `log` file for unexpected messages.

All other data files are so-called SPACAR Binary data Files (SBF), which implies that these are in a binary format and cannot be read easily by a user. Therefore, utilities are provided to read and modify data in these files, see page 8. Depending on the mode up to three binary output files may be created.

For all modes a SPACAR Binary Data file with filename identical to the input file and extension `sbd` is written. The contents of this file are also stored in MATLAB arrays, that are of course immediately available in the MATLAB workspace e.g. to be visualized with the standard MATLAB graphics commands, such as `plot` (see e.g. Chapter 3 and Appendix C). The following variables are created or overwritten:

<code>mode</code>	SPACAR mode number	
<code>ndof</code>	number of kinematic DOFs	
<code>nddf</code>	number of dynamic DOFs	
<code>nx</code>	number of coordinates	
<code>ne</code>	number of deformation parameters	
<code>nxp</code>	number of fixed, calculable, input and dynamic coordinates	
<code>nep</code>	number of fixed, calculable, input and dynamic deformation parameters	
<code>lnp</code>	location matrix for the nodes	*1
<code>le</code>	location matrix for the elements	*1
<code>ln</code>	connection matrix for the nodes in the elements	*2
<code>it</code>	list of element types	*2
<code>time</code>	time column vector	
<code>x</code>	coordinates (nodal displacements)	
<code>xd</code>	nodal velocities	
<code>xdd</code>	nodal accelerations	
<code>fx</code>	prescribed nodal forces/moments	
<code>fxtot</code>	reaction forces/moments	
<code>e</code>	generalized deformations	
<code>ed</code>	velocities of generalized deformations	
<code>edd</code>	accelerations of generalized deformations	
<code>sig</code>	generalized stress resultants	
<code>de</code>	first order geometric transfer function for the deformations $\mathbf{D}\mathcal{F}^{(e)}$	*3
<code>dx</code>	first order geometric transfer function for the coordinates $\mathbf{D}\mathcal{F}^{(x)}$	*3
<code>d2e</code>	second order geometric transfer function for the deformations $\mathbf{D}^2\mathcal{F}^{(e)}$	*3
<code>d2x</code>	second order geometric transfer function for the coordinates $\mathbf{D}^2\mathcal{F}^{(x)}$	*3
<code>xcompl</code>	location vector for directional nodal compliances	*4
<code>rxyz</code>	initial orientations of elements	*2

Notes:

\*1 The two location matrices provide information to find the location of a specific quantity in the data matrices:

- `lnp` location matrix for the nodes. The matrix element  $lnp(i, j)$  denotes the location of the  $j^{\text{th}}$  coordinate ( $j=1..4$ ) of node  $i$ .
- `le` location matrix for the elements. The matrix element  $le(i, j)$  denotes the location of the  $j^{\text{th}}$  generalized deformation ( $j=1..6$ ) of element  $i$ .

The locations of undefined or unused coordinates and deformations equal zero.

For example, the  $x$ - and  $y$ -coordinates of node 7 can be shown as function of time in a graph by typing

```
>> plot(time,x(:,lnp(7,1:2)))
```

and the first generalized stresses in elements 1, 2 and 3 can be plotted by typing

```
>> plot(time,sig(:,le(1:3,1)))
```

Obviously, storage in the  $x$ ,  $xd$ ,  $xdd$ ,  $fx$ ,  $e$ ,  $ed$ ,  $edd$  and  $sig$  matrices is like  $x(t,k)$  where  $t$  is the time step and  $k$  ranges from 1 to  $nx$  for  $x$ ,  $xd$ ,  $xdd$  and  $fx$ ,  $fx_{tot}$  and from 1 to  $ne$  for  $e$ ,  $ed$ ,  $edd$  and  $sig$ , respectively.

- \*2 The variables  $ln$ ,  $it$  and  $rxxyz$  are mainly intended for internal use in the drawing tool `spadraw`. More user-friendly information is available in the `log` file, page 7.
- \*3 The (large) variables  $de$ ,  $dx$ ,  $d2e$  and  $d2x$  are only created if the parameters of the `LEVELLOG` are set accordingly, Sect. 2.2.
- \*4 After a linearization run (`mode=8`) directional nodal compliances (inverse stiffnesses) are computed. Using the location matrix, `xcomp1(lnp(i,j))` gives this quantity for the  $j^{\text{th}}$  coordinate ( $j=1..4$ ) of node  $i$ .

After a linearization run (`mode=3, 4, 7, 8` or `9`) the coefficient matrices are stored in a SPACAR Binary Matrix file with extension `sbm`. The accompanying MATLAB matrices are:

$m_0$	reduced mass matrix $M_0$	*5
$b_0$	input matrix $B_0$	*5, *6
$c_0$	velocity sensitivity matrix $C_0$	*5
$d_0$	damping matrix $D_0$	*5
$k_0$	structural stiffness matrix $K_0$	*5
$n_0$	geometric stiffness matrix $N_0$	*5
$g_0$	geometric stiffness matrix $G_0$	*5

Notes:

- \*5 Storage of the time-varying matrices is in a row for each time step, so in  $m_0(t,k)$  index  $t$  is the time step and  $k$  ranges from 1 to  $ndof \times ndof$ . To restore the matrix structure at some time step type e.g. `reshape(m_0(t,:),ndof,ndof)`.
- \*6 Only available for `mode=4` and `9`.

In `mode=2, 3, 4` and `9` a so-called `ltv` file is created. The contents of this file varies and is not automatically imported to the MATLAB workspace. From a `mode=2` run the following data is available (the names indicate the identities of the data used in the file; identities marked with “\*” are available at each time step):

NNOM	number of (actuator) inputs	
NY	number of outputs	
T	time	*

U0	nominal input for the desired motion	*
Y0	reference output of the desired motion	*

In the addition the linearization runs yield additional setpoints, state space matrices and other data in the `ltv` file (not all identities are always present):

NNOM	number of (actuator) inputs	
NX	number of states ( $2 \times \text{ndof}$ )	
NU	number of inputs (length of U0)	
NY	number of outputs (length of Y0)	
NRBM	number of rigid body DOF's	
NYS	number of outputs with 2 <sup>nd</sup> order expression	
DFT	direct feedthrough flag ( $D \neq 0$ )	
X0	initial state vector	
T	time	*
A	state space system matrix	*
B	state space input matrix	*
C	state space output matrix	*
D	state space direct feedthrough matrix	*
G	second order output tensor	*
M0	mass matrix $M_0$	*
C0B	combined damping matrix $C_0 + D_0$	*
K0B	combined stiffness matrix $K_0 + N_0 + G_0$	*
SIG0	generalized stress resultants	*

The `getss` tool can be used to read the state space matrices from the `ltv` file, see page 8. Other utilities are available to use parts of these data in a SIMULINK environment, e.g. to read setpoints or to simulate a Linear Time-Varying (LTV) system (see Sect. 1.4).

## The log file

The `log` file contains an analysis of the input and possible errors and warnings that are encountered. The error and warning messages are explained in more detail in Appendix B. The other output can be separated into a number of blocks.

The first lines indicate the version and release date of the software and a copyright note.

Next the lines from the input file read by the KIN module are shown (not showing comments present in the input file), see also Sect. 2.2. From the analysis is written:

- The elements used in this model. The deformations of all elements are shown with the internal numbers according to the `le` array and the classification of each deformation: O = fixed, C = calculable and M = DOF.
- The nodal point information with the internal numbers of the coordinates according to the `lnp` array and the classification as above.
- Finally a list shows the degrees of freedom. Dynamic degrees of freedom are indicated.

The DYN module reads the next data block and processed input lines are shown. From the analysis we get

- The numbers NEO, NEMM, NEM and NEC indicate the numbers of deformations in each class as explained in the lecture notes [1].

- The numbers NXO, NXC, NXMM and NXM indicate the numbers of position coordinates in each class as explained in the lecture notes [1].
- The stiffness, damping and mass of the elements.
- The nodal point forces, mass and gyroscopic terms.
- The total mass of the system.

The zeroth, first, second and third order transfer functions are shown next, each for the position parameters and deformation parameters, respectively. The amount of output can be controlled by the keyword `OUTLEVEL` in the input file.

Next for a forward analysis (`mode=1` and `mode=4`) the name of the integrator and accuracy settings are shown. Finally a list with all time steps and the number of internal iterations are given. For an inverse dynamics analysis the trajectories and input/output definitions (see also Sect. 2.4) are read and analysed. In case of `mode=3` the name of the data file of the previous `mode=2` is shown. In case of `mode=7` the eigen values (frequencies) and normalized eigenvectors of the state system matrix are shown. In case of `mode=8` load multipliers and normalized buckling modes are presented. In addition the vector of directional nodal compliances is shown.

## SPACAR Binary data Files

Some utilities are available to show, check, load or replace the data in SPACAR Binary data Files (SBF) files. These are files with extensions `sbd`, `sbm` and `ltv`.

`checksbf` check and shows the contents of a SPACAR Binary data File. The output for each variable is the name (“Id”), the type (1 for integer, 2 for real, 3 for text) and the size (number of rows and columns). First the “header” variables are shown with their value. Long vectors may be truncated. Between `TDEF` and `TDAT` the time-varying data is given. The number of time steps equals the number of rows specified for `TDEF`.

`getfrsbf` extract a variable from a SPACAR Binary data File. The “Id” must be specified and for time-varying data the time step as well.

`repinsbf` replaces the value of a variable in a SPACAR Binary data File. The “Id” must be specified and for time-varying data the time step as well.

`loadsbd` loads all data from a SPACAR Binary Data (`sbd`) file into MATLAB’s workspace.

`loadsbm` loads all data from a SPACAR Binary Matrix data (`sbm`) file into MATLAB’s workspace.

`getss` loads the state space matrices at one time instant from a SPACAR `ltv` file into a state space system in MATLAB’s workspace.

`combsbd` combines data from two or more SPACAR Binary Data (`sbd`) files into a single output file. The specified output file is overwritten without a warning.

`spadraw` is the plotting utility used internally by SPACAR. It can also be used to visualize results after a simulation has been completed.

For all utilities additional online help is available by typing `help` command at the MATLAB prompt.

## Limitations

The SPACAR package has some built-in limitations on the size of the manipulators that can be analysed. Table 1.1 shows the limits for the so-called “Student version” that can be downloaded as describes in Appendix A. In case your requirements are larger, you need to contact the authors. The licence for the freely downloadable software is time limited.

Maximum number of coordinates/deformations	175
Maximum number of DOFs	20
Maximum number of elements/nodal points	50
Maximum number of inputs	12
Maximum number of outputs	25

**Table 1.1.** Built-in limitations of the “Student version” of the SPACAR package.

## 1.3 SPAVISUAL

SPAVISUAL is the visualization tool for SPACAR. It can visualize deformation, vibration and buckling modes. SPAVISUAL shows beams, trusses, and hinges in 2-D as well as in 3-D. It works with default settings which can be adjusted by the user. The only input of SPAVISUAL is a filename. This file has to be a `.dat` file which has been analysed with SPACAR. This is necessary because SPAVISUAL needs the `.sbd` files for the deformation modes and also the `.sbm` files for the vibration and the buckling modes. There are a couple of keywords that can adjust the default settings. These keywords are listed in section 2.7.

SPAVISUAL is a stand-alone function in MATLAB. To run SPAVISUAL the user has to type the next command.

```
>> spavisual('filename')
```

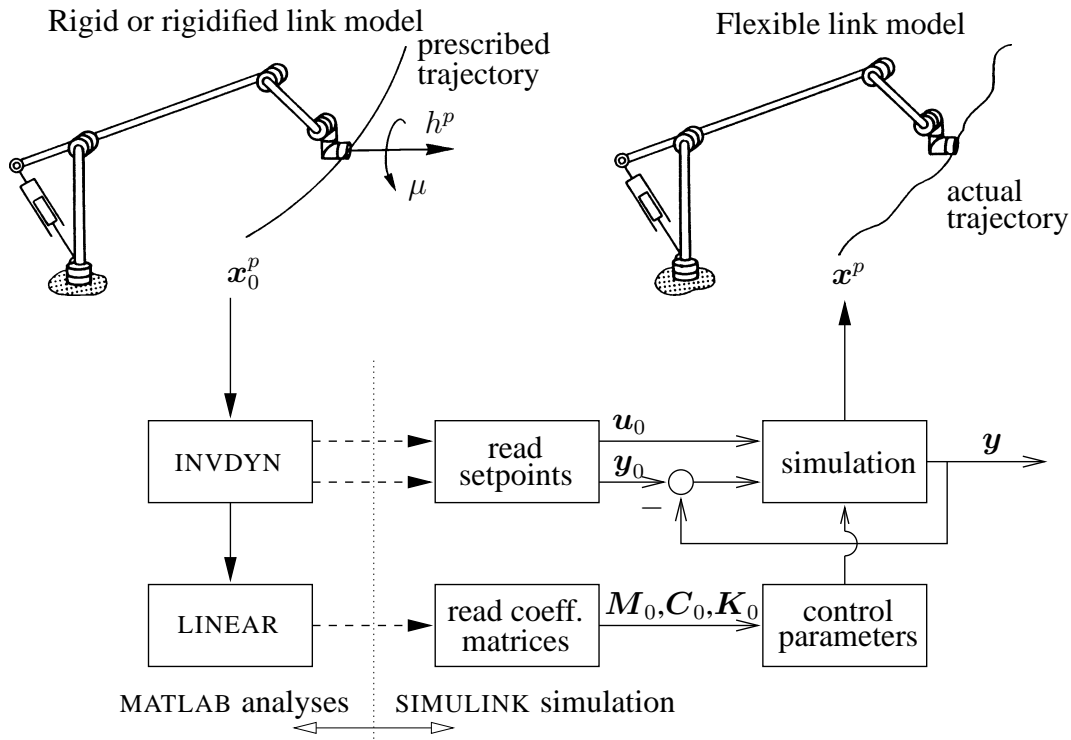
Here `filename` refers to the `.dat`-file that is executed by SPACAR.

## 1.4 SPASIM and SIMULINK

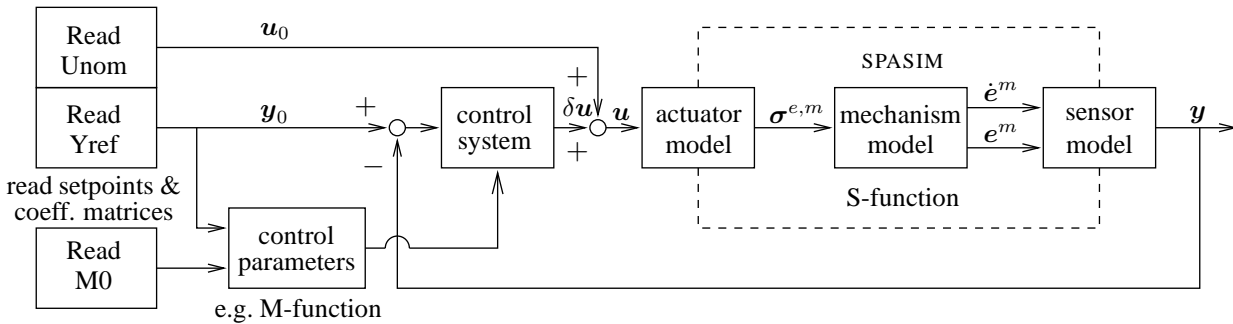
The behaviour of a manipulator mechanism with e.g. closed-loop control can be simulated using SIMULINK. The closed-loop simulation is defined as the problem of computing the actual trajectory of e.g. the manipulator tip with controlled actuation of the motion. Tracking errors with respect to a nominal prescribed trajectory can be calculated.

Figure 1.2 shows an overview of a typical simulation scheme. The simulation is characterized by the inverse dynamics stage, based on a rigid link model and a forward dynamic stage. At the forward dynamics stage the tracking behaviour of the manipulator system is studied. In the case of flexible manipulators additional generalized coordinates ( $\varepsilon_i^m$ ) describing the elastic behaviour of the manipulator links can be used in the dynamic system.

The block diagram in Fig. 1.3 shows a typical closed-loop simulation in more detail. Blocks are used from the SPACAR SIMULINK library `spacar_lib` that is part of the SPACAR package. These blocks are front-ends to so-called S-functions in SIMULINK [3]. The following blocks are provided:



**Figure 1.2.** Typical overview with MATLAB analyses and a SIMULINK simulation.



**Figure 1.3.** Block diagram of a typical closed-loop simulation in SIMULINK. The left blocks read setpoints and coefficient matrices stored in data files during previous SPACAR analyses (Fig. 1.1).

1. SPASIM: The non-linear open-loop model of the manipulator with its actuators and sensors. It operates comparable to the forward dynamic mode in SPACAR as discussed for the MATLAB interface in Sect. 1.2. The mechanism is defined in an input data file of file type `dat`. The filename of the input file must be specified. An output `log` file is written. Note that in a SIMULINK simulation the integration is determined by the SIMULINK environment, e.g. the kind of solver, the step size and tolerances. The degrees of freedom of the mechanism and their first time derivatives are the “states” of the SPACAR S-function. The dimensions of the input and output vectors are determined from the input file and should match the requirements of the other SIMULINK blocks they are connected to.
2. LTV: simulation of a Linear Time-Varying system as defined in an `l tv` file, see Sect. 1.5.
3. Setpoint U0: Reads the nominal input from an `l tv` file with setpoints generated e.g.



with `mode=2` or `3`. The `filename` must be specified. The setpoints are interpolated between the specified time steps. The interpolation method can be chosen from: Stepwise, Linear (default) and Spline. The block has no input and the dimension of the output vector equals the number of nominal inputs found in the file.

4. Setpoint `Sigma0`: Reads  $\sigma_0$  from an `ltv` file generated with e.g. `mode=3`, see Sect. 1.5.
5. Reference `Y0`: Reads the reference output from an `ltv` data file with setpoints. The `filename` must be specified. Interpolation is as above. This block has no input and the dimension of the output vector equals the number of reference outputs found in the file.
6. Times `M0`: Reads the square reduced mass matrix  $M_0$  from an `ltv` file generated with e.g. `mode=3`. The output of the block equals the input of the block is multiplied with the mass matrix. The `filename` must be specified. In the case not the full dimension of  $M_0$  in the `ltv` is used, the reduced dimension has to be specified. All elements of  $M_0$  are interpolated linearly (default) or stepwise. The dimension of the output vector equals the dimension of the input vector.

In the block diagram in Fig. 1.3 the output vector  $\mathbf{y}$  of the SPASIM block is compared to the reference output vector  $\mathbf{y}_0$ . The difference of these vectors is the input of the control system. The state matrices can be used to develop and tune a controller of any type (e.g. linear, non-linear, discrete, continuous) by means of the available software tools in MATLAB and SIMULINK. The output of the controller  $\delta\mathbf{u}$  is added to the nominal input vector  $\mathbf{u}_0$  to actuate the mechanism. An example is discussed in Sect. 3.11.

When using blocks from the SPACAR SIMULINK library `spacar_lib` note the following:

- Using any of the LTV, Setpoint `U0`, Setpoint `Sigma0`, Reference `Y0` and Times `M0` blocks at times beyond the last time step found in the data file may lead to unexpected results.
- In the current version of the software all `spasim` blocks in a block diagram should refer to the same input filename. Analogously, all LTV, Setpoint `U0`, Setpoint `Sigma0`, Reference `Y0` and Times `M0` must use the same `ltv` file.

## 1.5 Perturbation method and modal techniques

For systems with a larger number of degrees of freedom the required computer time for a SPASIM simulation may be unacceptable, in particular when high frequency eigenfrequencies play a role. Then the *perturbation method* may provide a numerical efficient solution strategy. Consider e.g. the motion of the flexible manipulator depicted in Fig. 1.2. In the case the flexibility is taken into account, the generalized coordinates or degrees of freedom can be written as

$$\mathbf{q} = \begin{bmatrix} \mathbf{e}^m \\ \boldsymbol{\varepsilon}^m \end{bmatrix}, \quad (1.9)$$

where  $\mathbf{e}^m$  represent the large relative displacements and rotations and  $\boldsymbol{\varepsilon}^m$  are the flexible deformation parameters. Due to the flexibility the actual trajectory motion will deviate from the

prescribed motion. If the deviations are small compared to the large scale motion, then the (small) vibrational motion of the manipulator can be modelled as a first-order perturbation  $\delta\mathbf{q}$  of the nominal rigid link motion  $\mathbf{q}_0$  by writing for the degrees of freedom

$$\mathbf{q} = \mathbf{q}_0 + \delta\mathbf{q}. \quad (1.10)$$

The perturbation method involves two steps:

1. Compute nominal rigid link motion  $\mathbf{q}_0$  from the non-linear equations of motion with all flexible deformation parameters  $\boldsymbol{\varepsilon}^m \equiv \mathbf{0}$ . This analysis will also provide the nominal input  $\mathbf{u}_0$  of the manipulator necessary to carry out the nominal motion and the generalized stress resultants (Lagrange multipliers)  $\boldsymbol{\sigma}_0^{\varepsilon^m}$  of the *rigidified* deformations, i.e. the flexible deformations that are prescribed zero.
2. Compute the vibrational motion  $\delta\mathbf{q}$  from linearized equations of motion

$$\bar{\mathbf{M}}_0\delta\ddot{\mathbf{q}} + \bar{\mathbf{C}}_0\delta\dot{\mathbf{q}} + \bar{\mathbf{K}}_0\delta\mathbf{q} = \boldsymbol{\sigma}_0, \quad (1.11)$$

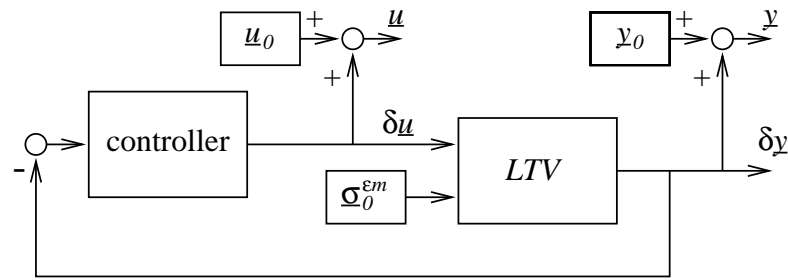
where  $\bar{\mathbf{M}}_0$  is the reduced mass matrix,  $\bar{\mathbf{C}}_0$  includes the velocity sensitivity and damping matrices and all stiffness matrices are combined into  $\bar{\mathbf{K}}_0$ . The righthand side equals

$$\boldsymbol{\sigma}_0 = \begin{bmatrix} \delta\mathbf{u} \\ \boldsymbol{\sigma}_0^{\varepsilon^m} \end{bmatrix}, \quad (1.12)$$

where  $\delta\mathbf{u} = \mathbf{u} - \mathbf{u}_0$  is the actual control action  $\mathbf{u}$  minus the nominal input  $\mathbf{u}_0$ . The previously computed generalized stress resultants  $\boldsymbol{\sigma}_0^{\varepsilon^m}$  are now applied as internal excitation forces.

To solve the linearized equations of motion (1.11) these are expressed as a Linear Time Varying (LTV) system. A SPACAR mode=3 run generates time varying state space matrices that are well suited for this purpose. Then a typical SPACAR analysis and linearized simulation procedure is as follows:

- Use e.g. an inverse dynamics run (mode=2) to define the nominal motion for the rigidified manipulator. Inputs and outputs of the system may be specified.
- Next the system is linearized with a mode=3 call. The system is analysed along the nominal path computed previously. The elastic deformations are defined with INPUTE commands. Inputs and outputs must be specified.
- Finally the linearized simulation can be run with a SIMULINK model of which a typical example is shown in Fig. 1.4. In comparison with the non-linear simulation of Fig. 1.3 the `spasim` block is replaced by an LTV block that uses the linearized equations of motion. Note that now only the differences compared to the nominal motion are computed. Only the difference  $\delta\mathbf{u}$  of the manipulator's input compared to the nominal input is needed. In addition, the generalized stress resultants  $\boldsymbol{\sigma}_0^{\varepsilon^m}$  are part of the input of the LTV block.



**Figure 1.4.** Block diagram of a typical closed-loop simulation in SIMULINK based on the perturbation method.

In addition to the above outlined standard implementation some further extensions are provided. It is possible to include the effect of proportional controller gain, i.e. a proportional control matrix  $\mathbf{K}_p$ , into the stiffness matrix  $\bar{\mathbf{K}}_0$ . Of course, in that case this part of the control action should no longer be included in the controller in the block scheme.

This approach offers advantages when subsequently a modal analysis is applied to the linear time varying state space system. Such an analysis discriminates quasi-static behaviour of the system, low frequent vibrational modes and high frequent vibrational modes. Mostly the latter do not significantly affect the output of the system while they can have a detrimental effect on the computational efficiency, even for a linearized system. With a modal analysis it is possible to eliminate these high frequency modes.

A more profound description of the latter two techniques is currently outside the scope of this manual.



# Keywords

## 2.1 Introduction

In this chapter the user is informed about the creation of correct input data for the software package SPACAR. The input must have a specific form. Behind a number of permitted keywords the user supplies a list of arguments. The arguments behind a keyword are well defined. Each module of SPACAR, except `mode=4` of `LINEAR`, has its own list of available keywords. They form blocks that are separated by the following pair of keywords:

```
END  
HALT
```

The final closure of the input is effected by:

```
END  
END
```

The first block contains the kinematic data. The input of the mechanism model (by means of keywords) is treated in the “Kinematics” section 2.2. A second block of input is reserved for the dynamics module. The keywords for this block are presented in the “Dynamics” section 2.3. The solution of inverse dynamics problems demands additional input for the trajectory description and for the definition of the input and output vectors  $\mathbf{u}_0$  and  $\mathbf{y}_0$ . Trajectory keywords and system keywords are treated in the “Inverse dynamics” section 2.4. The keywords for the linearization of `mode=3` are given in the “Linearization” section 2.5. At the end of the file custom settings for `SPAVISUAL` can be added. The keywords for `SPAVISUAL` are presented in section 2.7. The simulation of mechanisms using `SIMULINK` is controlled by the keywords described in the “Simulation” section 2.6.

Some general remarks:

- Keywords and arguments can be separated by one or more spaces, tabs or line breaks.
- Lines must not contain more than 160 characters.

- Any text in a line following a #, % or ; is treated as a comment.
- All input is case insensitive.
- Data read from the input file are echoed in the log file, *after* the comments have been removed and all text is transformed into upper case (capitals).
- Angles are always specified in radians.
- For commands like XF and STARTDE not all arguments have to be specified. Default values are zero unless otherwise specified.

## 2.2 Kinematics

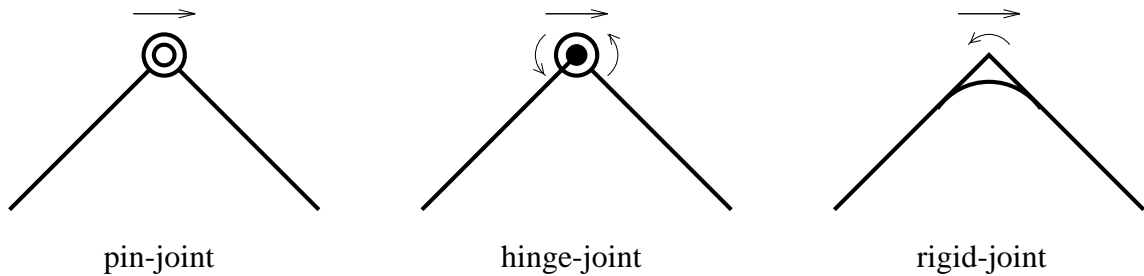
A kinematic mechanism model can be built up with finite elements by letting them have nodal points in common. The nodal coordinates of the finite elements are described by position and orientation coordinates. Therefore, two types of nodes are distinguished: *position* or *translational nodes*, denoted by  $\vec{p}$  for node  $p$ , and *orientation* or *rotational nodes* denoted by  $\hat{p}$ . The nodes, nodal coordinates, and deformation parameters for the truss, beam, planar bearing, hinge and pinbody (rigid beam) element are summarized in Table 2.1.

keyword	type	end node $p$		end node $q$		deformation parameters
		$\rightarrow$	$\curvearrowright$	$\rightarrow$	$\curvearrowright$	
PLBEAM	planar beam	$\mathbf{x}^p$	$\phi^p$	$\mathbf{x}^q$	$\phi^q$	$e_1, e_2, e_3$
PLTRUSS	planar truss	$\mathbf{x}^p$	–	$\mathbf{x}^q$	–	$e_1$
PLTOR	planar hinge	–	$\phi^p$	–	$\phi^q$	$e_1$
PLBEAR	planar bearing	$\mathbf{x}^p$	$\phi^p$	$\mathbf{x}^q$	$\phi^q$	$e_1, e_2, e_3$
PLPINBOD	planar pinbody	$\mathbf{x}^p$	$\phi^p$	$\mathbf{x}^q$	–	$e_1, e_2$
PLRBEAM	planar rigid beam	$\mathbf{x}^p$	$\phi^p$	$\mathbf{x}^q$	–	$e_1, e_2$
BEAM	spatial beam	$\mathbf{x}^p$	$\lambda^p$	$\mathbf{x}^q$	$\lambda^q$	$e_1, e_2, e_3, e_4, e_5, e_6$
TRUSS	spatial truss	$\mathbf{x}^p$	–	$\mathbf{x}^q$	–	$e_1$
HINGE	spatial hinge	–	$\lambda^p$	–	$\lambda^q$	$e_1, e_2, e_3$
PINBODY	spatial pinbody	$\mathbf{x}^p$	$\lambda^p$	$\mathbf{x}^q$	–	$e_1, e_2, e_3$
RBEAM	spatial rigid beam	$\mathbf{x}^p$	$\lambda^p$	$\mathbf{x}^q$	–	$e_1, e_2, e_3$

**Table 2.1.** Nodes, nodal coordinates, and deformation parameters for the planar and spatial truss, beam, bearing, hinge and pinbody elements.

Usually, the convention is made that node  $p$  of an element is assigned to the lower number of the element nodes, and that node  $q$  is assigned to the higher node number. The interconnections

between the elements are accomplished by indicating common nodes between the elements. For instance, with a pin-joint connection only the translational nodes are shared. In case of a hinge-joint connection only the rotational nodes are shared whereas translational coordinates can either be shared or unshared. When elements are rigidly connected to each other, both the translational and rotational nodes are shared, see Fig. 2.1. It can be observed from Table 2.1 that a truss element and a hinge element do not have common nodal types and therefore cannot be connected to each other.



**Figure 2.1.** Joint connections between finite elements.

In the first block of the kinematics module either two-dimensional (planar) or three-dimensional (spatial) elements can be specified. In the second block the initial configuration of the mechanism is specified. In the third block the coordinates and generalized deformations are divided into four groups, depending on the boundary conditions:

1. fixed prescribed coordinates (supports)
2. dependent, calculable deformations
3. prescribed, time-dependent coordinates
4. dynamic degrees of freedom

For the keywords in the third block it is important to remark that there are no keywords to fix a deformation or to release a coordinate. These are the default settings. So a deformation is fixed unless a `RLSE`, `INPUTE` or `DYNE` keyword specifies otherwise. Similarly, a coordinate is calculable unless a `FIX`, `INPUTX` or `DYNX` keyword specifies otherwise.

With the keywords of the fourth optional block, the calculation of some non-linear terms in the expressions for the deformations of planar or spatial beams can be suppressed and geometric properties for `PINBODY` elements and their cognates (rigid beam, planar pinbody, planar rigid beam) can be specified.

The keyword in the fifth section is not really a kinematic keyword as it sets the level of output from the program.

<b>KEYWORDS KINEMATICS</b>
----------------------------

1

PLBEAM	Planar beam element.
PLTRUSS	Planar truss element.
PLTOR	Planar hinge element.
PLBEAR	Planar bearing element (not supported !!).
PLPINBOD	Planar pinbody element.
PLRBEAM	Planar rigid beam element.
BEAM	Beam element.
TRUSS	Truss element.
HINGE	Hinge element.
PINBODY	Spatial pinbody element.
RBEAM	Spatial rigid beam element.

2

X	Specification of the initial Cartesian nodal positions.
---	---

3

FIX	Support coordinates $\boldsymbol{x}^0$ .
RLSE	Calculable deformations $\boldsymbol{e}^c$ .
INPUTX	Prescribed DOF $\boldsymbol{x}^m$ .
INPUTE	Prescribed DOF $\boldsymbol{e}^m$ .
DYNX	Dynamic DOF $\boldsymbol{x}^m$ .
DYNE	Dynamic DOF $\boldsymbol{e}^m$ .

4

LDEFORM	Suppresses the calculation of non-linear elastic strains of a beam element, due to possibly large curvatures of the elastic line.
ORPINBOD	Defines the orientations of the generalized deformations for the PINBODY elements and cognates.
DRPINBOD	Defines the undeformed reference distances for the PINBODY elements and cognates.

5

OUTLEVEL	Sets the level of output generated in the log file and in the SPACAR Binary Data (sbd) file.
----------	--

The parameters for these keywords are listed below.  $\{ *i \}$  refers to note  $i$  listed at the end of the keywords.



PLBEAM	1 2 3 4 5	element number first position node first orientation node second position node second orientation node
PLTRUSS	1 2 3	element number first position node second position node
PLTOR	1 2 3	element number first orientation node second orientation node
PLPINBOD	1 2 3 4	element number first position node first orientation node second position node
PLRBEAM	1 2 3 4	element number first position node first orientation node second position node
BEAM	1 2 3 4 5 [ 6–8	element number first position node first orientation node second position node second orientation node initial direction of the principal $y'$ -axis of the beam cross-section ] { *1 }
TRUSS	1 2 3	element number first position node second position node
HINGE	1 2 3 4–6	element number first orientation node second orientation node initial direction of the $x'$ -axis of rotation { *2 }
PINBODY	1 2 3 4 [ 5–7	element number first position node first orientation node second position node initial direction of the principal $y'$ -axis of the beam cross-section ] { *3 }
RBEAM	1 2 3 4 [ 5–7	element number first position node first orientation node second position node initial direction of the principal $y'$ -axis of the beam cross-section ] { *1 }

X	1	position node number
	2	$x_1$ -coordinate
	3	$x_2$ -coordinate
	[ 4	$x_3$ -coordinate ] { *4 }

FIX	1	node number
	[ 2–	coordinate number (1, 2, 3 or 4) ] { *5 }
RLSE	1	element number
	[ 2–	deformation mode coordinate number (1, 2, 3, 4, 5 or 6) ] { *6 }
INPUTX	1	node number
	[ 2–	coordinate number (1, 2, 3 or 4) ] { *5 }
INPUTE	1	element number
	[ 2–	deformation mode coordinate number (1, 2, 3, 4, 5 or 6) ] { *6 }
DYNX	1	node number
	[ 2–	coordinate number (1, 2, 3 or 4) ] { *5 }
DYNE	1	element number
	[ 2–	deformation mode coordinate number (1, 2, 3, 4, 5 or 6) ] { *6 }

LDEFORM	1	BEAM element number
ORPINBOD	1	PINBODY, RBEAM, PLPINBOD or PLRBEAM element number
	2–10	direction vectors { *7 }
DRPINBOD	1	PINBODY, RBEAM, PLPINBOD or PLRBEAM element number
	2	undeformed projection of $\mathbf{x}^q - \mathbf{x}^p$ on the first direction vector
	3	undeformed projection of $\mathbf{x}^q - \mathbf{x}^p$ on the second direction vector
	[ 4	undeformed projection of $\mathbf{x}^q - \mathbf{x}^p$ on the third direction vector for spatial elements ]

OUTLEVEL	1	level of output in log file { *8 }
	[ 2	level of output in the SPACAR Binary Data (sbd) file] { *8 }

## NOTES:

- \*1 The direction vector lies in the local  $x'y'$ -plane of the beam element. If no direction is specified, the local direction vector is chosen as the standard basis vector that makes the largest angle with axis of the beam; in case of a draw, the vector with the highest index is chosen.

- \*2 The local  $y'$  and  $z'$  unit vectors are chosen as follows. First, the standard basis vector with the largest angle with the hinge axis is chosen; in case of a draw, the vector with the highest index is chosen. Then the local  $y'$  is chosen in the direction of the cross product of the local  $x'$ -direction with this basis vector. The local  $z'$ -direction is chosen so as to complete an orthogonal right-handed coordinate system.
- \*3 If no direction is specified, directions initially aligned with the global coordinate axes are chosen; otherwise the line connecting the translational node is chosen as the local  $x'$ -direction, the specified vector is in the local  $x'y'$ -plane. The directions used are made orthonormal.
- \*4 The specification of the initial positions with the keyword X is only required for non-zero position-coordinates. The initial orientations cannot be chosen freely.
- \*5 If the keywords INPUTX, DYNX and FIX are used without an explicit specification of the coordinate, all (independent) coordinates will be marked as degrees of freedom or supports. This means that  $x_1$ ,  $x_2$  (and  $x_3$ ) are marked for position nodes and  $\beta$  or  $\lambda_1$ ,  $\lambda_2$  and  $\lambda_3$  for orientation nodes. If more than one coordinate is specified, each of the specified coordinates is chosen as a degree of freedom or a support.
- \*6 If the keywords INPUTE, DYNE and RLSE are used without an explicit specification of the deformation mode coordinate, all deformation mode coordinates will be marked as degrees of freedom or released. If more than one deformation mode coordinate is specified, each of the specified coordinates is chosen as a degree of freedom or as released.
- \*7 There are four distinct cases, two for the planar elements and two for the spatial elements. For the planar elements, if two numbers are specified, this is the direction of the local  $x'$ -axis and an orthogonal  $y'$ -direction is found by rotating by a right angle in the positive direction and the directions are normalized; if four numbers are specified, these are taken as the direction vectors in the local  $x'$ - and  $y'$ -directions as they are. For the spatial elements, if six numbers are specified, these are taken as the direction of the  $x'$ -axis and a direction in the local  $x'y'$ -plane, which are made orthonormal and completed by a local  $z'$ -axis; if nine numbers are specified, these are taken as the three direction vectors as they are.
- \*8 Both parameters for the outputs level are integers of which the values are the sum of the desired outputs. A value of 0 implies the least output; an output level of  $-1$  means maximum output; to obtain multiple outputs, the specified values for the parameters should be added.  
For the first parameter for the log file are defined:

- 0 Default: All “normal” output.
- 1 Additional output of the first order geometric transfer functions in  $d_e$  and  $d_x$ .
- 2 Additional output of the second order geometric transfer functions in  $d^2e$  and  $d^2x$  for  $mode=4, 7, 8$  and  $9$ .
- 4 Additional output of the third order geometric transfer functions in  $d^3e$  and  $d^3x$  for  $mode=4, 7, 8$  and  $9$ .
- 8 Additional output of the derivative of the global deformation function for  $mode=4, 7, 8$  and  $9$ .

For the second parameter (SPACAR Binary Data (*sbd*) file) are defined:

- 0 Default for all modes except  $mode=7, 8$  and  $9$ : All “normal” output.
- 1 Default for  $mode=7, 8$  and  $9$ : Additional output of the first order geometric transfer functions in  $d_e$  and  $d_x$ .
- 2 Additional output of the second order geometric transfer functions in  $d^2e$  and  $d^2x$ .
- 3 Additional output of the first and second order geometric transfer functions (a combination of 1 and 2).

## 2.3 Dynamics

With the keywords of the dynamics module the following blocks of information can be supplied. Blocks 1 and 2 are optional. If deformable elements have been defined in the kinematics, block 3 has to be filled, lest the stiffness and damping are zero. If the motion is not prescribed by trajectories, block 4 has to be used to define the input motion. Finally with the keywords from the 5<sup>th</sup> block miscellaneous settings can be adjusted.

### KEYWORDS DYNAMICS

1	<table border="1"> <tbody> <tr> <td>XM</td> <td>Inertia specification of lumped masses.</td> </tr> <tr> <td>EM</td> <td>Inertia specification of distributed element masses.</td> </tr> <tr> <td>BEAMINER</td> <td>Specification of inertia terms for rigid spatial beam elements with uniform mass distribution (no longer supported).</td> </tr> <tr> <td>XGYRO</td> <td>Inertia specification of gyrostat.</td> </tr> <tr> <td>MEE</td> <td>User-defined mass put into <math>M^{(e,e)}</math>.</td> </tr> </tbody> </table>	XM	Inertia specification of lumped masses.	EM	Inertia specification of distributed element masses.	BEAMINER	Specification of inertia terms for rigid spatial beam elements with uniform mass distribution (no longer supported).	XGYRO	Inertia specification of gyrostat.	MEE	User-defined mass put into $M^{(e,e)}$ .		
XM	Inertia specification of lumped masses.												
EM	Inertia specification of distributed element masses.												
BEAMINER	Specification of inertia terms for rigid spatial beam elements with uniform mass distribution (no longer supported).												
XGYRO	Inertia specification of gyrostat.												
MEE	User-defined mass put into $M^{(e,e)}$ .												
2	<table border="1"> <tbody> <tr> <td>XF</td> <td>External force specification of the mechanism in nodes.</td> </tr> <tr> <td>USERSIG</td> <td>Specification of MATLAB M-file for user functions with input for forces and stresses.</td> </tr> </tbody> </table>	XF	External force specification of the mechanism in nodes.	USERSIG	Specification of MATLAB M-file for user functions with input for forces and stresses.								
XF	External force specification of the mechanism in nodes.												
USERSIG	Specification of MATLAB M-file for user functions with input for forces and stresses.												
3	<table border="1"> <tbody> <tr> <td>ESTIFF</td> <td>Specification of elastic constants.</td> </tr> <tr> <td>ESIG</td> <td>Specification of preloaded state.</td> </tr> <tr> <td>EDAMP</td> <td>Specification of viscous damping coefficients.</td> </tr> </tbody> </table>	ESTIFF	Specification of elastic constants.	ESIG	Specification of preloaded state.	EDAMP	Specification of viscous damping coefficients.						
ESTIFF	Specification of elastic constants.												
ESIG	Specification of preloaded state.												
EDAMP	Specification of viscous damping coefficients.												
4	<table border="1"> <tbody> <tr> <td>TIMESTEP</td> <td>Duration and number of time steps.</td> </tr> <tr> <td>INPUTX</td> <td>Specification of simple time functions for the prescribed degrees of freedom.</td> </tr> <tr> <td>INPUTE</td> <td>Specification of initial values for the dynamic degrees of freedom.</td> </tr> <tr> <td>STARTDX</td> <td>Specification of initial values for the dynamic degrees of freedom.</td> </tr> <tr> <td>STARTDE</td> <td>Specification of initial values for the dynamic degrees of freedom.</td> </tr> <tr> <td>USERINP</td> <td>Specification of MATLAB M-file for user functions with input for the degrees of freedom.</td> </tr> </tbody> </table>	TIMESTEP	Duration and number of time steps.	INPUTX	Specification of simple time functions for the prescribed degrees of freedom.	INPUTE	Specification of initial values for the dynamic degrees of freedom.	STARTDX	Specification of initial values for the dynamic degrees of freedom.	STARTDE	Specification of initial values for the dynamic degrees of freedom.	USERINP	Specification of MATLAB M-file for user functions with input for the degrees of freedom.
TIMESTEP	Duration and number of time steps.												
INPUTX	Specification of simple time functions for the prescribed degrees of freedom.												
INPUTE	Specification of initial values for the dynamic degrees of freedom.												
STARTDX	Specification of initial values for the dynamic degrees of freedom.												
STARTDE	Specification of initial values for the dynamic degrees of freedom.												
USERINP	Specification of MATLAB M-file for user functions with input for the degrees of freedom.												
5	<table border="1"> <tbody> <tr> <td>INTEGRAT</td> <td>Select integrator.</td> </tr> <tr> <td>ERROR</td> <td>Specification of error tolerances for the integrator.</td> </tr> <tr> <td>ITERSTEP</td> <td>Specification of number of iterations and steps and error tolerance for static calculations in modes 7, 8 and 9.</td> </tr> </tbody> </table>	INTEGRAT	Select integrator.	ERROR	Specification of error tolerances for the integrator.	ITERSTEP	Specification of number of iterations and steps and error tolerance for static calculations in modes 7, 8 and 9.						
INTEGRAT	Select integrator.												
ERROR	Specification of error tolerances for the integrator.												
ITERSTEP	Specification of number of iterations and steps and error tolerance for static calculations in modes 7, 8 and 9.												

The parameters required with these keywords are listed below.  $\{*i\}$  refers to note  $i$  listed at the end of the keywords.

XM	1	node number	
	2	concentrated mass for position nodes, rotational inertia $I$ for plane orientation nodes, for spatial orientation nodes, the inertia components	
		$J_{xx} \{*1\}$	
	3	$J_{xy} \{*1\}$	
	4	$J_{xz} \{*1\}$	
	5	$J_{yy} \{*1\}$	
	6	$J_{yz} \{*1\}$	
	7	$J_{zz} \{*1\}$	
EM	1	element number	
	2	mass per unit of length	
	[ 3	rotational inertia $J_{x'x'}$ per unit of length for spatial beam rotational inertia $J$ per unit of length for planar beam ]	
	[ 4	rotational inertia $J_{y'y'}$ per unit of length for spatial beam ]	
	[ 5	rotational inertia $J_{z'z'}$ per unit of length for spatial beam ]	
	[ 6	rotational inertia $J_{y'z'}$ per unit of length for spatial beam ]	
XGYRO	1	node number	
	2	$\Omega_1$ } components of absolute angular rotor velocity (free rotor motion) or components of constant angular rotor velocity relative to the carrier body (prescribed rotor motion)	
	3		$\Omega_2$ }
	4		$\Omega_3$ }
	5	rotor inertia $J$	
	6	type of rotor motion (0: free, 1: prescribed)	
MEE	1	first element number	
	2	deformation coordinate of first element	
	[ 3	second element number	
	4	deformation coordinate of second element ]	
	3/5	entry in the mass matrix $M^{(e,e)} \{*2\}$	
XF	1	node number	
	2	forces dual with the 1 <sup>st</sup> node coordinate	
	[ 3-5	forces dual with the 2 <sup>nd</sup> , 3 <sup>rd</sup> and 4 <sup>th</sup> node coordinate ]	
USERSIG	1	Name of the MATLAB M-file with user functions with forces and stresses $\{*3\}$	

ESTIFF	1	element number
	2	$EA$ for beam and truss elements $S_1 = S_t$ for hinge elements $S_1$ , first stiffness coefficient for pinbody and cognates
	[ 3	$GI_t$ for spatial beam $EI$ for planar beam $S_2$ , second stiffness coefficient for pinbody and cognates ] {*4}
	[ 4	$EI_{y'}$ for spatial beam $EI/(GAk)$ for planar beam $S_3$ , third stiffness coefficient for pinbody and cognates ] {*4}
	[ 5	$EI_{z'}$ for spatial beam ] {*4}
	[ 6	$EI_{y'}/(GAk_{z'})$ for spatial beam ] {*4}
	[ 7	$EI_{z'}/(GAk_{y'})$ for spatial beam ] {*4}
ESIG	1	element number
	2	preloaded force in beam, pinbody and truss elements and torque in hinge elements
EDAMP	1	element number
	2	$E_d A$ , longitudinal damping for beam and truss elements $S_{d1}$ , torsional damping for hinge elements $S_{d1}$ , first damping coefficient for pinbody and cognates
	[ 3	$G_d I_t$ , torsional damping for beam elements $E_d I$ , bending damping for planar beams $S_{d2}$ , second damping coefficient for pinbody and cognates ] {*4}
	[ 4	$E_d I_{y'}$ , bending damping in $y'$ -direction for spatial beams $S_{d3}$ , third damping coefficient for pinbody and cognates ] {*4}
	[ 5	$E_d I_{z'}$ , bending damping in $z'$ -direction for spatial beam ] {*4}

TIMESTEP	1	length of time period
	2	number of time steps
INPUTX	1	node number (position or orientation node) {*5}
	2	coordinate number (1, 2, 3 or 4)
	3	start value
	4	start rate
	5	acceleration (constant)
INPUTE	1	element number {*6}
	2	deformation mode coordinate number (1, 2, 3, 4, 5 or 6) {*7}
	3	start value {*8}
	4	start rate
	5	acceleration (constant)
STARTDX	1	node number
	2	coordinate number (1, 2, 3 or 4)
	3	start value
	4	start rate
STARTDE	1	element number
	2	deformation mode coordinate number (1, 2, 3, 4, 5 or 6)
	3	start value {*8}
	4	start rate
USERINP	1	Name of the MATLAB M-file with user defined input functions {*9}

INTEGRAT	1	Specify integrator type {*10}
ERROR	1	Absolute error for the integrator
	2	Relative error for the integrator
ITERSTEP	1	maximal number of iterations in calculating a stationary solution (default value 10)
	2	number of load steps (default value 4)
	3	error tolerance (default value 5.0E-7)

## NOTES:

- \*1 The inertia components are related to the global coordinate system  $(x, y, z)$  in the initial configuration.
- \*2 The keyword MEE is used to add a fixed mass coupled to deformation mode coordinates. If all five numbers are specified, the mass is placed as a coupling between the two deformation mode coordinates; if three numbers are specified, the mass is placed on the diagonal.
- \*3 The (required) parameter of the USERSIG keyword is the name of a MATLAB M-file without the extension .m and with a maximum filename length of 8 characters. The calling syntax of the M-script is



function [time,sig,f]=pushsig(t,ne,le,e,ep,nx,lnp,x,xp);

The input parameters are the time  $t$  and a list of variables that store the instantaneous values of the same quantities as are represented by the corresponding variables in the SPACAR Binary Data, see the overview on page 5. The script should return (again) time  $t$ , user defined stressed  $\text{sig}$  and user defined nodal forces  $\text{fx}$ . Either  $\text{sig}$  or  $\text{fx}$  or both may be empty in the case no stresses and/or forces are prescribed. Otherwise each row in  $\text{sig}$  and/or  $\text{fx}$  should define one stress value or force component at the specified time  $t$ . Three columns should be provided with

1. The element number ( $e$ ) or the node number ( $x$ ).
2. The deformation mode number ( $e$ ) or the coordinate number ( $x$ ).
3. The current value of the stress or force component.

\*4 Unspecified values for the stiffness and damping are assumed to be zero by default. The meaning of the variables is:  $E$ , elasticity modulus (Young's modulus);  $G = E/(2 + 2\nu)$ , shear modulus;  $\nu$ , Poisson's ratio;  $E_d$ , damping modulus in Kelvin–Voigt model;  $G_d$ , shear damping modulus in Kelvin–Voigt model;  $A$ , cross-sectional area;  $I$  ( $I_{y'}$ ,  $I_{z'}$ ), second area moment (about  $y'$ -axis and  $z'$ -axis);  $I_t$ , Saint-Venant's torsion constant;  $k$  ( $k_{y'}$  and  $k_{z'}$ ), shear correction factor (in  $y'$ -direction and  $z'$ -direction). The shear correction nfactors are about 0.85; a table of values for various cross-sections can be found in [5].

The generalized stresses are calculated according to the Kelvin–Voigt model as follows. All first stresses are calculated as  $\sigma_1 = S_1\varepsilon_1 + S_{d1}\dot{\varepsilon}_1 + \sigma_0$ , where  $S_1 = EA/l_0$  and  $S_{d1} = E_dA/l_0$  for the truss and beam elements, where  $l_0$  is the undeformed length of the element, and the first stiffness and damping coefficients as defined in the input for the other types of elements.  $\sigma_0$  is the preload defined by the keyword `ESIG`. For hinge and pinbody elements, the other stresses are calculated in an analogous way, but without the preload. For a planar beam element, the bending stresses are calculated as

$$\begin{bmatrix} \sigma_2 \\ \sigma_3 \end{bmatrix} = \frac{S_2}{1 + \Phi} \begin{bmatrix} 4 + \Phi & -2 + \Phi \\ -2 + \Phi & 4 + \Phi \end{bmatrix} \begin{bmatrix} \varepsilon_2 \\ \varepsilon_3 \end{bmatrix} + \frac{S_{d2}}{1 + \Phi} \begin{bmatrix} 4 + \Phi & -2 + \Phi \\ -2 + \Phi & 4 + \Phi \end{bmatrix} \begin{bmatrix} \dot{\varepsilon}_2 \\ \dot{\varepsilon}_3 \end{bmatrix},$$

where  $S_2 = EI/l_0^3$ ,  $\Phi = 12EI/(GAk_{z'}l_0^2)$  and  $S_{d2} = E_dI/l_0^3$ . For a spatial beam element, the torsional stress is calculated as  $\sigma_2 = S_2\varepsilon_2 + S_{d2}\dot{\varepsilon}_2 + \sigma_0$ , where  $S_2 = GI_t/l_0^3$  and  $S_{d2} = G_dI_t/l_0^3$ ; note the wacky occurrence of  $\sigma_0$  here. For bending along the local  $y'$ - and  $z'$ -axes, the stresses are, analogous to the planar case,

$$\begin{bmatrix} \sigma_3 \\ \sigma_4 \end{bmatrix} = \frac{S_3}{1 + \Phi_z} \begin{bmatrix} 4 + \Phi_z & -2 + \Phi_z \\ -2 + \Phi_z & 4 + \Phi_z \end{bmatrix} \begin{bmatrix} \varepsilon_3 \\ \varepsilon_4 \end{bmatrix} + \frac{S_{d3}}{1 + \Phi_z} \begin{bmatrix} 4 + \Phi_z & -2 + \Phi_z \\ -2 + \Phi_z & 4 + \Phi_z \end{bmatrix} \begin{bmatrix} \dot{\varepsilon}_3 \\ \dot{\varepsilon}_4 \end{bmatrix}$$

and

$$\begin{bmatrix} \sigma_5 \\ \sigma_6 \end{bmatrix} = \frac{S_4}{1 + \Phi_y} \begin{bmatrix} 4 + \Phi_y & -2 + \Phi_y \\ -2 + \Phi_y & 4 + \Phi_y \end{bmatrix} \begin{bmatrix} \varepsilon_5 \\ \varepsilon_6 \end{bmatrix} + \frac{S_{d4}}{1 + \Phi_y} \begin{bmatrix} 4 + \Phi_y & -2 + \Phi_y \\ -2 + \Phi_y & 4 + \Phi_y \end{bmatrix} \begin{bmatrix} \dot{\varepsilon}_5 \\ \dot{\varepsilon}_6 \end{bmatrix},$$

where  $S_3 = EI_{y'}/l_0^3$ ,  $\Phi_z = 12EI_{y'}/(GAk_{z'}l_0^2)$ ,  $S_{d3} = E_dI_{y'}/l_0^3$ ,  $S_4 = EI_{z'}/l_0^3$ ,  $\Phi_y = 12EI_{z'}/(GAk_{y'}l_0^2)$ , and  $S_{d4} = E_dI_{z'}/l_0^3$ .

- \*5 In a `mode=7, 8` or `9` run a (deformed) mechanism configuration is computed which corresponds with the specified nodal position.
- \*6 Stiffness and damping properties of the corresponding element are not used for the dynamic computations.  
In a `mode=7, 8` or `9` run a (deformed) mechanism configuration is computed which corresponds with the specified element deformation.
- \*7 Rotational deformations are defined in radians.
- \*8 Note that the keyword `X` defines an initial configuration in which the deformations are zero. A start value defined with `INPUTE` or `STARTDE` defines a deformation with respect to the initial configuration.
- \*9 The (required) parameter of the `USERINP` keyword is the name of a MATLAB M-file without the extension `.m` and with a maximum filename length of 8 characters. The calling syntax of the M-script is

```
function [t,e,x]=mymotion(t,is);
```

The input parameters are the time  $t$  and time step number  $is$ . The script should return (again) time  $t$ , prescribed deformations  $e$  and prescribed coordinates  $x$ . Either  $e$  or  $x$  may be empty in the case no deformations or coordinates are prescribed. Otherwise each row in  $e$  and/or  $x$  should define one deformation or coordinate at the specified time  $t$ . Five columns should be provided with

1. The element number ( $e$ ) or the node number ( $x$ ).
2. The deformation mode number ( $e$ ) or the coordinate number ( $x$ ).
3. The current value of the deformation ( $e$ ) or coordinate ( $x$ ).
4. The current rate of the deformation ( $\dot{e}$ ) or velocity ( $\dot{x}$ ).
5. The current acceleration of the deformation ( $\ddot{e}$ ) or coordinate ( $\ddot{x}$ ).

The user has to assure the correctness of the derivatives. SPACAR does not carry out any checks, but the results depend heavily on these derivatives.

- \*10 Available integrator types are:
  - 0 Default: Shampine-Gordon.
  - 1 Runge-Kutta.
  - 2 2<sup>nd</sup> order Runge-Kutta.
 Change this only if you know what you are doing.

## 2.4 Inverse dynamics (setpoint generation)

For clarity the keywords for the inverse dynamics including the generation of setpoints are discussed in two subsections. In the input file keywords from both subsections must be combined into one part, so there should be **no** END/HALT pair in between.

### 2.4.1 Trajectory generation

There are three essential keywords blocks:

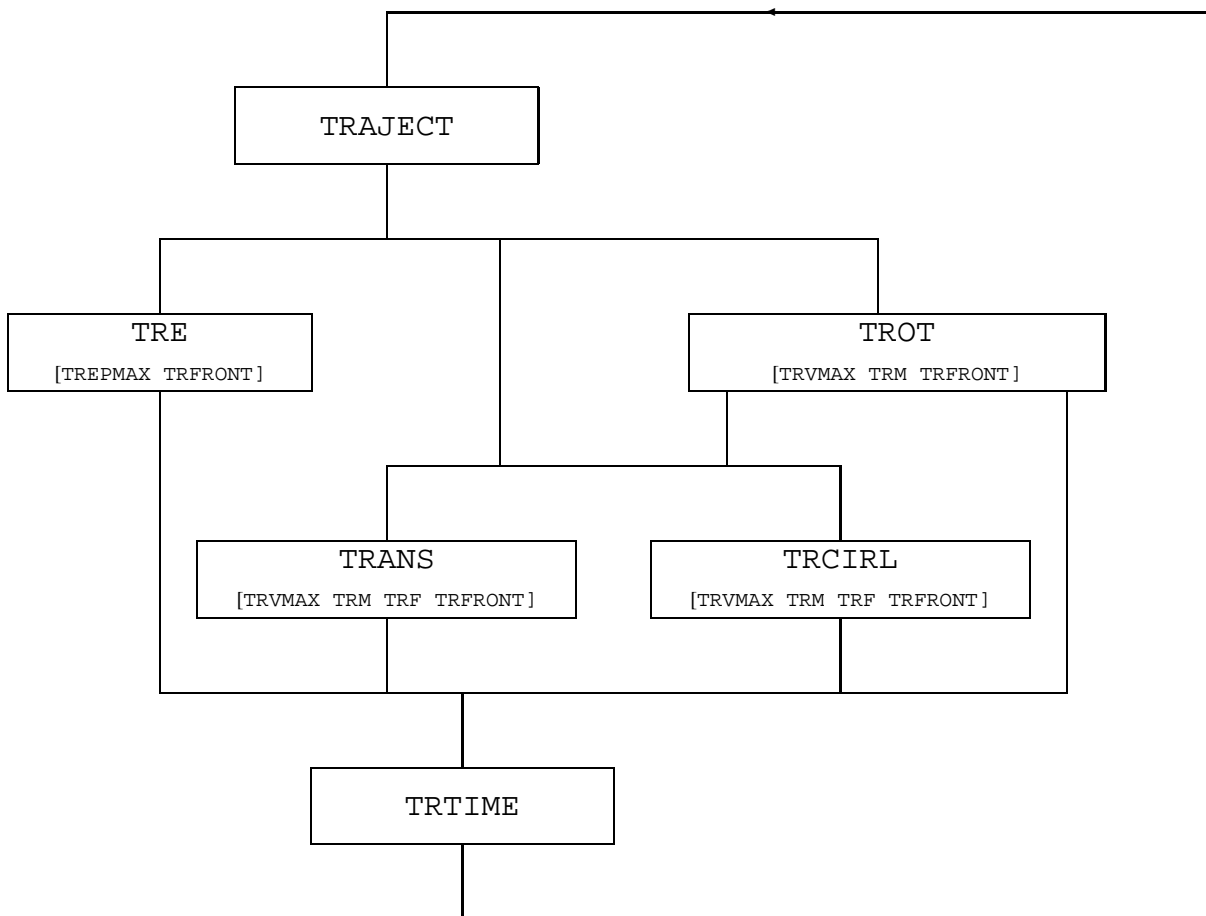
<b>KEYWORDS TRAJECTORY GENERATION</b>			
1	<table border="1"> <tr> <td style="text-align: center;">TRAJECT</td> <td>Trajectory header, the given trajectory number is valid for all keywords before the next TRAJECT.</td> </tr> </table>	TRAJECT	Trajectory header, the given trajectory number is valid for all keywords before the next TRAJECT.
TRAJECT	Trajectory header, the given trajectory number is valid for all keywords before the next TRAJECT.		
2	<table border="1"> <tr> <td style="text-align: center;">TROT TRANS TRCIRL TRE  USERTRAJ</td> <td>           Definition of the actual trajectory:            the number and type of DOFs determine which and how many keywords have to be specified:            TROT, TRANS, and TRCIRL for nodes and TRE for elements (maximum of 6).             Trajectory defined by a user function.         </td> </tr> </table>	TROT TRANS TRCIRL TRE  USERTRAJ	Definition of the actual trajectory: the number and type of DOFs determine which and how many keywords have to be specified: TROT, TRANS, and TRCIRL for nodes and TRE for elements (maximum of 6).  Trajectory defined by a user function.
TROT TRANS TRCIRL TRE  USERTRAJ	Definition of the actual trajectory: the number and type of DOFs determine which and how many keywords have to be specified: TROT, TRANS, and TRCIRL for nodes and TRE for elements (maximum of 6).  Trajectory defined by a user function.		
3	<table border="1"> <tr> <td style="text-align: center;">TRTIME</td> <td>Definition of trajectory time and number of time steps.</td> </tr> </table>	TRTIME	Definition of trajectory time and number of time steps.
TRTIME	Definition of trajectory time and number of time steps.		

And there are two blocks of optional keywords:

1	<table border="1"> <tr> <td style="text-align: center;">TREPMAX TRVMAX TRFRONT</td> <td>           Specification of velocity profile: rise time and maximum velocity.            Specification of acceleration front for each velocity profile.         </td> </tr> </table>	TREPMAX TRVMAX TRFRONT	Specification of velocity profile: rise time and maximum velocity. Specification of acceleration front for each velocity profile.
TREPMAX TRVMAX TRFRONT	Specification of velocity profile: rise time and maximum velocity. Specification of acceleration front for each velocity profile.		
2	<table border="1"> <tr> <td style="text-align: center;">TRM TRF</td> <td>Specification of extra masses and forces on the end-effector.</td> </tr> </table>	TRM TRF	Specification of extra masses and forces on the end-effector.
TRM TRF	Specification of extra masses and forces on the end-effector.		

The trajectories can be constructed in two ways: with a user function or with built-in profiles. The latter are defined below and are of course limited to (combinations of) the built-in profiles. On the other hand, practically any input can be generated with user functions. This feature is activated by defining exactly one `TRAJECT` with the `USERTRAJ` keyword. The (required) parameter is the name of an MATLAB M-script that is to be called. With `TRTIME` the total trajectory time and the number of time steps must be specified. The calling syntax of the M-script is exactly equal to that of the M-script for the `USERINP` keyword, see page 28.

Alternatively, one can use the built-in trajectory profiles. The next scheme shows in more detail the combination possibilities of the setpoint generation keywords. Essential keywords are accompanied by a number of optional keywords placed between brackets. Other optional keywords than mentioned are not allowed for that specific essential keyword.



The way to follow through the scheme is almost fully dictated by the number and type of degrees of freedom. Each trajectory is defined for the same DOF and therefore runs through the same branch of the scheme. Only `TRANS` and `TRCIRL` may be changed into one another after each trajectory.

At this stage it is useful to mention the way in which degrees of freedom are declared:

Position and orientation coordinates are declared as DOF by input-command

INPUTX node-number component-number

Deformation mode coordinates are declared as DOF by input-command

INPUTE element-number component-number

(INPUTX and INPUTE are “kinematic keywords”, Sect. 2.2).

So, degrees of freedom are declared separately. For generation of setpoints in relative coordinates (such as joint angles), each INPUTE in the kinematics input prepares one TRE in the setpoint generation input (only the first relative coordinate per element is allowed as input for the setpoint generation). For the positions and orientations the situation is more complex because a trajectory in two or three dimensions is defined on node level, not on coordinate level. The keywords TROT, TRANS and TRCIRL prescribe the motion of one node:

keyword	description	node type and type number		DOF
TROT	rotation about a	2-D orientation	1	$\phi$
	fixed axis in space	3-D orientation	4	$\phi, h_1, h_2, h_3$
TRANS	translation along a	2-D position	2	$x_1, x_2$
	straight line	3-D position	3	$x_1, x_2, x_3$
TRCIRL	translation along a	2-D position	2	$x_1, x_2$
	circle segment	3-D position	3	$x_1, x_2, x_3$

For the administration of trajectories two numbers are of main importance: the trajectory number and the node or element number. The trajectory number has to be given once after TRAJECT, node numbers or element numbers follow immediately after all other keywords. In this way information about the path, the velocity profile and additional loads can be grouped and worked up by node/element number. Taking as starting point the type of DOF the picture becomes:

	DOF	PATH	VELOCITY PROFILE		LOADS
<b>ELEMENT</b>	$e_1$	TRE	TREPMAX	TRFRONT	
<b>NODE</b>	$x_i$	TROT	TRVMAX	TRFRONT	TRM
		TRANS	TRVMAX	TRFRONT	TRM TRF
		TRCIRL	TRVMAX	TRFRONT	TRM TRF

The parameters required with these keywords are listed below.  $\{*i\}$  refers to note  $i$  listed at the end of the keywords.

TRAJECT	1	trajectory number
TROT	1 2 [ 3 4 5 ]	node number (orientation node) total angle in rad $h_1$ -coordinate of fixed rotation axis $h_2$ -coordinate $h_3$ -coordinate ]
TRANS	1 2 3 [ 4 ]	node number (position node) $x_1$ -coordinate of end position $x_2$ -coordinate $x_3$ -coordinate ]
TRCIRL	1 2-3 4-5 2-4 5-7	node number (position node) 2D: $c_1$ and $c_2$ coordinates of circle center point $\{*1\}$ 2D: $b_1$ and $b_2$ coordinates of circle end point $\{*1\}$ 3D: $c_1$ , $c_2$ and $c_3$ coordinates of circle center point $\{*1\}$ 3D: $b_1$ , $b_2$ and $b_3$ coordinates of circle end point $\{*1\}$
TRE	1 2	element number total displacement (relative angle or elongation)
USERTRAJ	1	name of M-script $\{*2\}$
TRTIME	1 2 [ 3 ]	total time for the trajectory number of time steps number of intermediate time steps ] $\{*3\}$
TREPMAX	1 2 [ 3 ]	element number rise time (period of acceleration) extreme velocity ] $\{*4\}$
TRVMAX	1 2 [ 3 ]	node number (position or orientation node) rise time (period of acceleration) extreme value of the velocity ] $\{*4\}$
TRFRONT	1 2	node or element number acceleration front type $\{*5\}$
TRM	1 2 [ 3 4 5 6 7 ]	node number (position or orientation node) extra mass ( $m$ , $I$ or $I_{xx}$ ) $J_{xy}$ $J_{xz}$ $J_{yy}$ $J_{yz}$ $J_{zz}$ ] $\{*6\}$
TRF	1 2 3 [ 4 ]	node number (position node) $f_1$ -coordinate of external force $f_2$ -coordinate $f_3$ -coordinate ]

## NOTES:

- \*1 The positions of the parameters of keyword TRCIRL are different in 2-D and in 3-D cases. Places 2–5 are used for 2-D, places 2–7 for 3-D. Note that the “endpoint” of the circle cannot be taken literally, as it is over-determined. The second point defines a line through the center on which the circle ends.
- \*2 See the note for the USERINP keyword on page 28.
- \*3 The keyword TRTIME has an optional third argument that influences the meaning of the second argument:

	2 arguments	3 arguments
1	total trajectory time	total trajectory time
2	number of time steps	number of time steps for an extended analysis
3		number of time steps within the previous step

For three arguments the total number of time steps is a multiplication of the last two arguments. In intermediate points a standard analysis is done.

- \*4 The keywords TRVMAX and TREPMAX have an optional third argument to express the extreme velocity (creation of a zero-acceleration period). If no extreme is given it can be calculated from the total time and path length. The second argument contains the rise-time. The period of deceleration is calculated from the (a) total time, (b) rise time, (c) total path length, (d) extreme velocity. In this way the velocity profile is fully determined. For asymmetrical velocity profiles the rise time can be calculated too. To indicate the symmetry of the profile the second argument is given a dummy argument: a non-positive value.  
The default velocity profile is: symmetrical without constant velocity period.
- \*5 The keyword TRFRONT has a second argument for the type of acceleration and deceleration function of time. There are three types of fronts:  
0 – constant acceleration  
1 – sine function (half period)  
2 – quadratic sine function (half period)  
The default velocity front has a constant acceleration (type 0).
- \*6 The keyword TRM has only for 3-D orientation nodes a real list of parameters. For 2-D orientation and position nodes one mass parameter is sufficient. In the 3-D case six values determine the symmetric rotational inertia matrix:

$$\begin{array}{rcc}
 J_{xx} & J_{xy} & J_{xz} & 1 & 2 & 3 \\
 & J_{yy} & J_{yz} & & 4 & 5 \\
 & & J_{zz} & & & 6
 \end{array}$$

## 2.4.2 Nominal inputs ( $u_0$ ) and reference outputs ( $y_0$ )

The nominal input vector  $u_0$  and the reference output vector  $y_0$  are defined in the following blocks. These blocks are optional, but omitting one or both blocks means that no input and/or output vectors are defined and hence no setpoints for that input and/or output vector are generated and written to the `ltv` file.

<b>KEYWORDS NOMINAL INPUT VECTOR <math>u_0</math> (mode=2)</b>	
1	
NOMS	Specification of actuator elements.
NOMF	Specification of actuated nodes.
<b>KEYWORDS REFERENCE OUTPUT VECTOR <math>y_0</math> (mode=2)</b>	
2	
REFE	Specification of the deformation parameters to be sensed.
REFEP	<i>Ibid.</i> first time derivative.
REFEDP	<i>Ibid.</i> second time derivative.
REFX	Specification of the nodal coordinates to be sensed.
REFXP	<i>Ibid.</i> first time derivative.
REFXDP	<i>Ibid.</i> second time derivative.

The parameters for these keywords are listed below.  $\{*i\}$  refers to note  $i$  listed at the end of the keywords.

NOMS	1	nominal input number $\{*1\}$
	2	element number
	3	deformation parameter number (1, 2, 3, 4, 5 or 6)
NOMF	1	nominal input number $\{*1\}$
	2	node number
	3	coordinate number (1, 2, 3, or 4)

REFE	1	reference output number $\{*1, 2\}$
	2	element number
	3	deformation parameter number (1, 2, 3, 4, 5 or 6)
REFX	1	reference output number $\{*1, 2\}$
	2	node number
	3	coordinate number (1, 2, 3, or 4)

### NOTES:

- \*1 The nominal input numbers and reference output numbers are the positions of the specified input or output in the input and output vectors, respectively.



- \*2 The keywords REFES and REFXS that are defined for the linearization module (Sect. 2.5) are accepted as well and do not give errors. Their meaning and usage is identical to the normal keywords REFE and REFX, respectively.

## 2.5 Linearization

As mentioned in Sect. 1.2 the module LINEAR is a forward dynamics stage for the generation of linearized equations of motion and state space matrices that can be used in two different modes.

mode=4 is basically an extension of the forward dynamic analysis of mode=1. No further keywords are required to obtain the coefficient matrices of the linearized equations as functions of the set of dynamic degrees of freedom  $q^d$ . These matrices are stored in a SPACAR Binary Matrix data file with extension `sbm`. This file can be loaded with the utility `loadsbm`. If input and output vectors  $\delta u$  and  $\delta y$  are defined, also the linearized state equations and output equations are computed (see mode=9).

Linearization in mode=3 is around a predefined nominal trajectory and takes place after that trajectory has been generated in an inverse dynamics run (mode=2). The set of DOFs used in the inverse dynamics computation represent the actuator joint coordinates  $e^m$ . In case of a flexible manipulator mechanism additional DOFs  $\varepsilon_i^m \equiv 0$  describing the elastic behaviour of the mechanism links should be included in the dynamic model (both in mode=2 and mode=3). Clearly, the mechanisms used in both runs have to be closely related. If the manipulation task is prescribed in terms of relative DOFs (TRE) the list of keywords is identical with those used in the inverse dynamics run (mode=2). If the manipulation task is prescribed as a motion of some nodal points (triads) (TROT, TRANS, TRCIRL) then the corresponding RLSE command of the actuators should be replaced by INPUTE commands in the kinematic block. In the software some checks are carried out to verify that data from the inverse dynamics run can be reasonably used during the linearization.

The nominal input vector  $u_0$  and the reference output vector  $y_0$  are again defined in the following blocks. These blocks are optional, but as before omitting one or both blocks means that no input and/or output vectors are defined and hence no state space matrices can be generated and written to the `ltv` file. The keywords are similar to the input and output keywords in Sect. 2.4.2. In the output `ltv` file of a mode=3 run the setpoints of the input and output vector are stored identically as for a mode=2 run. In addition the state space matrices for the linearized equations of motion (Sect. 1.5) are generated. Obviously, the input matrix  $B$  and output matrix  $C$  depend on the chosen input and output vectors. In a usual state space system the output vector is computed from a linear expression. In the case a larger accuracy is required, SPACAR can be instructed to use a second order expression. This feature is available for all deformation parameters and coordinates (not for the time derivatives) with the keywords REFES and REFXS. The use of these keywords will generate elements in the output reference vector that are the same like the elements from REFE and REFV, respectively. Also the associated row in the output matrix  $C$  is the same, but in addition a tensor denoted G in the `ltv` file is computed with the second order geometric transfer function.

Linearization in mode=7, 8 and 9 is around a pre-computed static equilibrium configuration, or a state of steady motion. In addition in mode=9 the state space matrix  $A$ , the input matrices  $B_0$  and  $B$ , the output matrix  $C$  and the feed through matrix  $D$  are calculated. Obviously, the matrices  $B_0$ ,  $B$ ,  $C$  and  $D$  depend on the chosen input and output vectors  $\delta u$  and  $\delta y$  respectively. These vectors are again defined in the blocks on page 38. These blocks are optional, but as before omitting one or both blocks means that no input and/or output vectors are defined and hence no state space matrices can be generated and written to the `ltv`-file.

**KEYWORDS NOMINAL INPUT VECTOR  $u_0$  (mode=3)**

1

NOMS	Specification of actuator elements.
NOMF	Specification of actuated nodes.

**KEYWORDS REFERENCE OUTPUT VECTOR  $y_0$  (mode=3)**

2

REFE	Specification of the deformation parameters to be sensed.
REFES	<i>Ibid.</i> with second order expression.
REFEP	<i>Ibid.</i> first time derivative.
REFEDP	<i>Ibid.</i> second time derivative (see note).
REFX	Specification of the nodal coordinates to be sensed.
REFXS	<i>Ibid.</i> with second order expression.
REFXP	<i>Ibid.</i> first time derivative.
REFXDP	<i>Ibid.</i> second time derivative (see note).

Note: Specifying second derivatives in the output vector implies an algebraic coupling between input and output, i.e. a non-zero state space matrix  $D$ . This is currently *not* implemented and the keywords REFEDP and REFSDP are ignored for the linearization.

The parameters for these keywords are listed below.  $\{*i\}$  refers to note  $i$  listed at the end of the keywords.

NOMS	1	nominal input number $\{*1\}$
	2	element number
	3	deformation parameter number (1, 2, 3, 4, 5 or 6)
NOMF	1	nominal input number $\{*1\}$
	2	node number
	3	coordinate number (1, 2, 3, or 4)

REFE REFES REFEP REFEDP	1	reference output number $\{*1\}$
	2	element number
	3	deformation parameter number (1, 2, 3, 4, 5 or 6)
REFX REFXS REFXP REFSDP	1	reference output number $\{*1\}$
	2	node number
	3	coordinate number (1, 2, 3, or 4)

## NOTES:

- \*1 The nominal input numbers and output output numbers are the positions of the specified input or output in the input and output vectors, respectively.

**KEYWORDS INPUT VECTOR  $\delta u$  (mode=4, 9)**

1

INPUTS	Specification of input stresses.
INPUTF	Specification of input forces.
INE	Specification of input deformation parameters.
INEP	<i>Ibid.</i> first time derivative.
INEDP	<i>Ibid.</i> second time derivative.
INX	Specification of input nodal coordinates.
INXP	<i>Ibid.</i> first time derivative.
INXDP	<i>Ibid.</i> second time derivative.

**KEYWORDS OUTPUT VECTOR  $\delta y$  (mode=4, 9)**

2

OUTS	Specification of output stresses.
OUTF	Specification of output forces.
OUTE	Specification of output deformation parameters.
OUTEP	<i>Ibid.</i> first time derivative.
OUTEDP	<i>Ibid.</i> second time derivative.
OUTX	Specification of output nodal coordinates.
OUTXP	<i>Ibid.</i> first time derivative.
OUTXDP	<i>Ibid.</i> second time derivative (see note).

The parameters for these keywords are listed below.  $\{ *i \}$  refers to note  $i$  listed at the end of the keywords.

INPUTS $\{ *2 \}$	1	input number $\{ *1 \}$
INE	2	element number
INEP	3	deformation parameter number (1, 2, 3, 4, 5 or 6)
INEDP		
INPUTF $\{ *4 \}$	1	input number $\{ *1 \}$
INX	2	node number
INXP	3	coordinate number (1, 2, 3, or 4)
INXDP		

OUTS $\{ *6 \}$	1	output number $\{ *1 \}$
OUTE	2	element number
OUTEP	3	deformation parameter number (1, 2, 3, 4, 5 or 6)
OUTEDP		
OUTF $\{ *8 \}$	1	output number $\{ *1 \}$
OUTX	2	node number
OUTXP	3	coordinate number (1, 2, 3, or 4)
OUTXDP		

## NOTES:

- \*1 The input numbers and output numbers are the positions of the specified inputs or outputs in the input and output vectors, respectively.
- \*2 Associated with dynamic DOFs  $e^{(m,d)}$ .
- \*3 Associated with prescribed deformations  $e^{(m,r)}$ .
- \*4 Associated with calculable coordinates  $x^{(c)}$  and/or dynamic DOFs  $x^{(m,d)}$ .
- \*5 Associated with prescribed nodal coordinates  $x^{(m,r)}$ .
- \*6 Associated with prescribed deformations  $e^{(0)}$  and/or  $e^{(m,r)}$ .
- \*7 Associated with calculable deformations  $e^{(c)}$  and/or dynamic DOFs  $e^{(m,d)}$ .
- \*8 Associated with prescribed nodal coordinates  $x^{(0)}$  and/or  $x^{(m,r)}$ .

## 2.6 Non-linear simulation of manipulator control

To simulate the behaviour of a manipulator with a control system the SPACAR program is also accessible as an “S-function” block SPASIM from SIMULINK. SIMULINK treats this block like a non-linear state-space system which has a state vector  $z$ , an input vector  $u$  and an output vector  $y$ . Each of these vectors has a well-defined meaning in the SPACAR block: The states correspond to the degrees of freedom and their first time derivatives. The input and output are coupled to actuators and coordinates as specified by keywords in the SPACAR input data file (see below). In the SIMULINK graphical user interface the input and output vectors must be coupled to other blocks like the control system. The states are used internally in SIMULINK and are usually not available to the user. That implies that any coordinate or deformation parameter that is used for control purposes or is monitored in a graph must be included in the output vector  $y$  (block 2).

### KEYWORDS INPUT VECTOR $u$ (SPASIM)

1

INPUTS	Specification of actuator elements.
INPUTF	Specification of actuated nodes.

### KEYWORDS OUTPUT VECTOR $y$ (SPASIM)

2

OUTE	Specification of the deformation parameters to be sensed.
OUTEP	<i>Ibid.</i> first time derivative.
OUTEDP	<i>Ibid.</i> second time derivative.
OUTX	Specification of the nodal coordinates to be sensed.
OUTXP	<i>Ibid.</i> first time derivative.
OUTXDP	<i>Ibid.</i> second time derivative.

The parameters for these keywords are listed below.  $\{*i\}$  refers to note  $i$  listed at the end of the keywords.

INPUTS	1	input number $\{*1\}$
	2	element number
	3	deformation parameter number (1, 2, 3, 4, 5 or 6)
INPUTF	1	input number $\{*1\}$
	2	node number
	3	coordinate number (1, 2, 3, or 4)

OUTE	1	output number $\{*1\}$
OUTEP	2	element number
OUTEDP	3	deformation parameter number (1, 2, 3, 4, 5 or 6)
OUTX	1	output number $\{*1\}$
OUTXP	2	node number
OUTXDP	3	coordinate number (1, 2, 3, or 4)

#### NOTES:

- \*1 The input numbers and output numbers are the positions of the specified input or output in the input and output vectors, respectively. They need not be identical to the nominal input vector and reference output vector specified during the generation of setpoints (see Sect. 2.4.2 and/or Sect. 2.5), but for a quite straightforward comparison it is convenient to use, at least partially, the same numbering scheme.

## 2.7 Visualization and animation

To adjust the default settings of SPAVISUAL the user can type VISUALIZATION after the last two END commands in the .dat file. All commands after the command VISUALIZATION are read by SPAVISUAL as an adjustment on the default settings.

BEAMVIS	Adjusts the height and the width of a beam element.
HINGEVIS	Adjusts the radius and the length of the hinge element.
TRUSSVIS	Sets the visualization of the truss element on or off.
TRANSPARENCY	Adjusts the transparency of the elements.
VIBRATIONMODE	Selects the vibration modes.
BUCKLINGMODE	Selects the buckling modes.
ENLARGFACTOR	Sets the amplitude of the vibration or buckling modes.
RECORDMOVIE	Sets recordmovie on or off, the movie is saved as an .avi file in the workspace.
MOVIEName	Sets the name of the recorded movie.
UNDEFORMED	Sets the visualization of the un-deformed mechanism on or off.
VIBREND	Sets the period of the sine function for the vibration mode.
STEPLINE	Sets the size of the line elements that are used to draw the elements.
STEPVIBRATION	Sets the number of steps in the vibration visualization.
LIGHT	Sets the light on or off.
JOINTS	Sets the joints on or off.
TRAJECTVIS	Sets the trajectory on or off.
TRAJECTNODE	Selects the node for the trajectory.



The parameters for these keywords are listed below.

KEYWORD	DESCRIPTION	DEFAULT SETTINGS
BEAMVIS {*1}	1 size of all beam elements in the local y' direction 2 size of all beam elements in the local z' direction	0.006 0.006
BEAMVIS {*1}	1 element number 2 size of the element for the local y' direction 3 size of the element for the local z' direction	0.006 0.006
HINGEVIS	1 element number 2 length of the hinge 3 radius of the hinge	0.003 0.009
TRUSSVIS	1 sets the visualization of the truss elements on (1) or off (0)	on
TRANSPARENCY	1 adjusts the transparency between (0) and (1)	1
VIBRATIONMODE	1 switch between the 10 lowest vibration modes {*2}	1
BUCKLINGMODE	1 switch between the 10 buckling modes {*2}	1
ENLARGFACTOR	1 amplitude of the vibration or buckling modes	1
RECORDMOVIE	1 sets record movie on (1) or off (0)	off
MOVIEFILENAME	1 filename for the recorded movie	filename
UNDEFORMED	1 sets the visualization of the initial (un-deformed) mechanism configuration on (1) or off (0)	on
VIBREND	1 sets the period of the sin function for the vibration mode	$2\pi$ {*3}
STEPLINE	1 sets the size of the line elements that are used to draw the elements	0.2
STEPVIBRATION	1 sets the number of intermediate steps in the vibration visualization	$\frac{\pi}{10}$ {*3}
LIGHT	1 sets the light source on (1) or off (0)	off
JOINTS	1 sets the joints on (1) or off (0)	on
TRAJECTVIS	1 sets the trajectory on (1) or off (0)	off
TRAJETCNODE	1 Select the node for the trajectory	1

### Notes

- \*1 The BEAMVIS command has two variations. The one with only two parameters adjusts all beam elements. The variant with three parameters can be used to adjust only a single beam element.
- \*2 Only the lowest vibration and buckling modes are available with a maximum of 10 modes.
- \*3 Only numerical values are allowed, no symbols or functions.



# Examples

The data files used to run the examples in this chapter can be downloaded from the SPACAR web site, see Appendix A.

## 3.1 Planar sliding bar

In example 4.3.1 of the lecture notes [1] the sliding bar of Fig. 3.1 is described. A rigid bar  $pq$  of length 2 m is suspended from two sliders. The bar is driven by the condition  $x^p - vt = 0$ , where  $v = |\mathbf{v}|$  is the constant horizontal velocity component of point  $p$ . Thus  $\dot{x}^p = v$  and  $\ddot{x}^p = 0$ . We want to compute  $\dot{y}^q$  and  $\ddot{y}^q$  for  $0 \leq t \leq 2\sqrt{3}$  s and  $v = 1$  m/s.

The position  $y^q$  can be computed easily from the symbolic expression  $y^q = \sqrt{4 - (\sqrt{3} - x^p)^2}$ , so

$$y^q = \sqrt{4 - (\sqrt{3} - t)^2}.$$

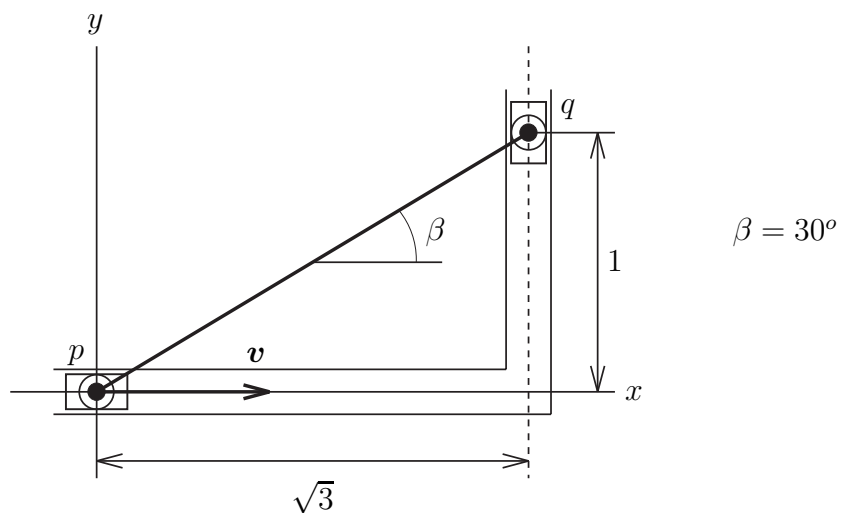


Figure 3.1. Sliding bar.

Differentiating once and twice with respect to the time  $t$  yields

$$\dot{y}^q = -\frac{-\sqrt{3} + t}{\sqrt{1 + 2\sqrt{3}t - t^2}}, \quad \ddot{y}^q = \frac{4}{(-1 - 2\sqrt{3}t + t^2)\sqrt{1 + 2\sqrt{3}t - t^2}}.$$

The mechanism has one degree of freedom and there is only one element. This is the planar truss element denoted by 1 that connects nodal points 1 and 2 in the following SPACAR input file (slider.dat):

```
PLTRUSS  1  1  2

X        1  0.  0.
X        2  1.7321  1.

FIX      1  2
FIX      2  1

INPUTX   1  1

END
HALT

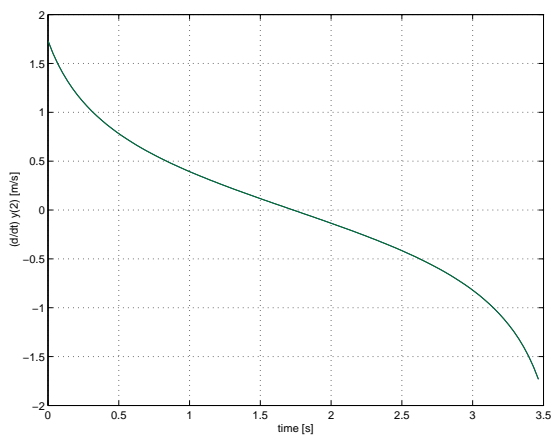
INPUTX   1  1  0.  1.  0.

TIMESTEP 3.4641  100

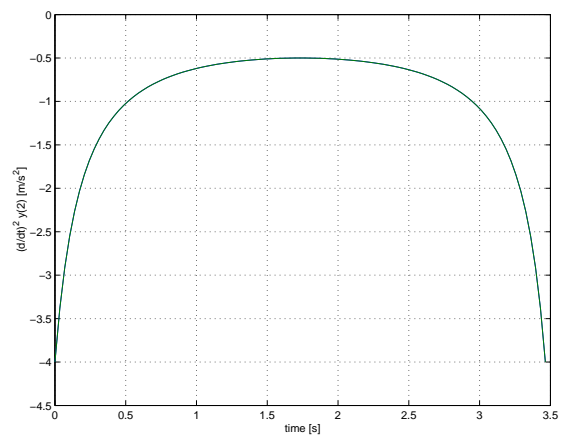
END
END
```

Both symbolic and numeric results are shown in Figs. 3.2 and 3.3 with the Matlab commands

```
>> t=time;
```



**Figure 3.2.** Vertical velocity  $\dot{y}^q$  of the sliding bar.



**Figure 3.3.** Acceleration  $\ddot{y}^q$  of the sliding bar.

```

>> plot(t,[xd(:,lnp(2,2)) ...
-(-3^(1/2)+t)./(1+2*3^(1/2)*t-t.^2).^(1/2)])
>> grid
>> xlabel('time [s]')
>> ylabel('(d/dt) y(2) [m/s]')
>> figure
>> plot(t,[xdd(:,lnp(2,2)) ...
4./(-1-2*3^(1/2)*t+t.^2)./(1+2*3^(1/2)*t-t.^2).^(1/2)])
>> grid
>> xlabel('time [s]')
>> ylabel('(d/dt)^2 y(2) [m/s^2]')

```

Obviously, in both graphs the symbolic and numeric are practically identical, which illustrates the good agreement between both solutions.

Note that in this example no masses are defined. There are also no dynamic degrees of freedom, so effectively only a kinematic problem is solved.

## 3.2 Planar slider–crank mechanism

The slider–crank mechanism is a frequently applied subsystem in the design of a mechanism. It finds its applications in combustion engines, compressors and regulators. Figure 3.4 presents a slider–crank mechanism for which three dynamics computations have to be carried out. In the first problem (case 1, see also example 5.7.2 in the lecture notes [1]), the crank and the connecting rod are assumed to be rigid. In the second computation (case 2), the connecting rod is shorter but still somewhat longer than the crank. In case 3, the flexibility of the connecting rod in the geometry of case 1 is taken into account, see also example 8.3.1 in the lecture notes [1].

### Case 1

First of all, the nodal coordinates must be specified. In the initial configuration, the crank and the connecting rod are horizontal. The crank length is 0.15 m, the length of the connecting rod is 0.30 m. For the dynamic analysis the following parameters are needed. The connecting rod

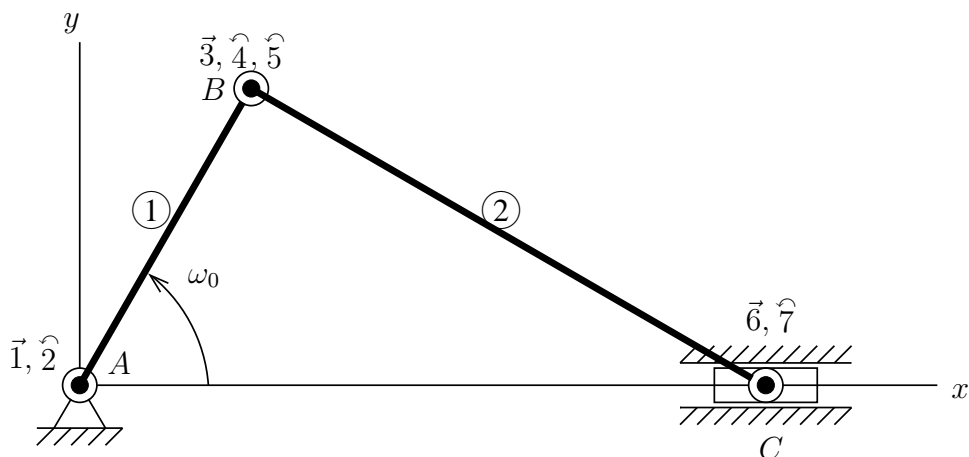


Figure 3.4. Planar slider–crank mechanism.

has a circular cross section with diameter  $d = 6$  mm. The mass density is  $\rho = 7.87 \cdot 10^3$  kg/m<sup>3</sup> and the Young's modulus is  $E = 2.1 \cdot 10^{11}$  N/m<sup>2</sup>. Consequently, the mass per unit length is 0.2225 kg/m and its total mass  $m_s = 0.06675$  kg. The mass of the sliding block or plunger  $C$  is given by  $m_C = \frac{1}{2}m_s = 0.033375$  kg. The crank is driven at a constant angular velocity  $\omega_0 = 150$  rad/s. The total simulation should comprise two crank rotations. Node  $B$  must be defined as a single translational node and a double rotational node, since the rotations of the slider and the crank are not the same. The mass of the crank is taken as zero.

An input file (crank.dat) describing this case is:

```

PLBEAM  1  1  2  3  4
PLBEAM  2  3  5  6  7

X        1      0.00  0.
X        3      0.15  0.
X        6      0.45  0.

FIX      1
FIX      6  2
INPUTX   2  1

END
HALT

XM       6      0.033375
EM       2      0.2225

INPUTX   2  1  0.    150.    0.
TIMESTEP      0.1  100

END
END

```

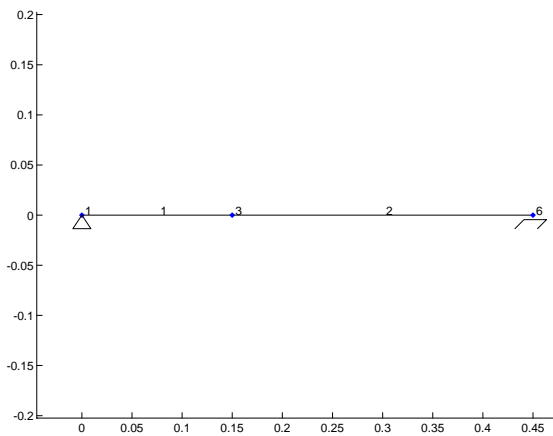
The initial configuration of case 1 is depicted in Fig. 3.5. The horizontal position, velocity and acceleration of the sliding block as function of time are given in Figs. 3.6–3.8. The driving moment in node 2 versus time is shown in Fig. 3.9 and the supporting forces acting on the sliding block are presented in Fig. 3.10.

The MATLAB commands used to plot these results are:

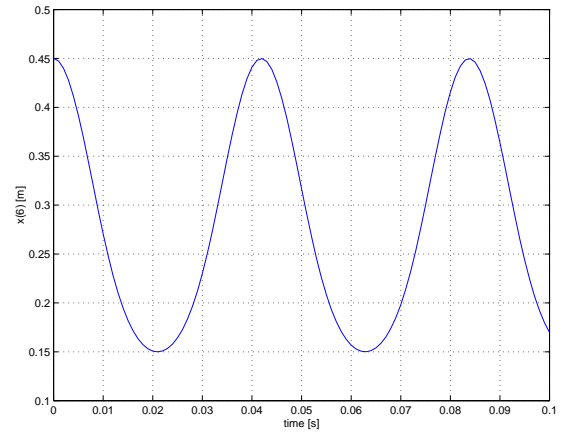
```

>> plot(time,x(:,lnp(6,1)))
>> grid
>> xlabel('time [s]')
>> ylabel('x(6) [m]')
>>
>> plot(time,xd(:,lnp(6,1)))
>> grid
>> xlabel('time [s]')
>> ylabel('(d/dt) x(6) [m/s]')
>>

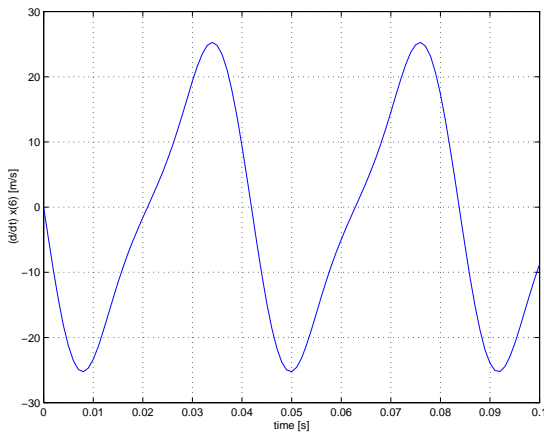
```



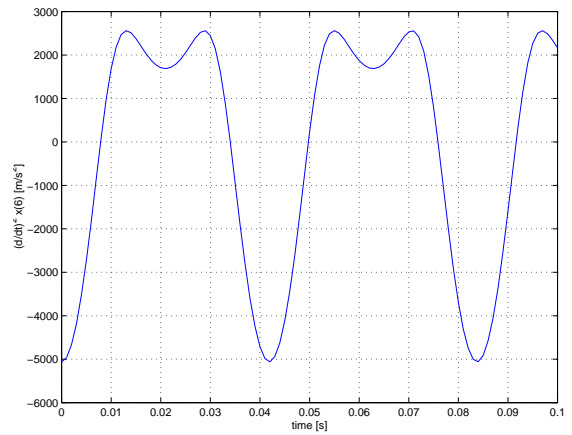
**Figure 3.5.** Case 1: Initial configuration of the slider-crank mechanism.



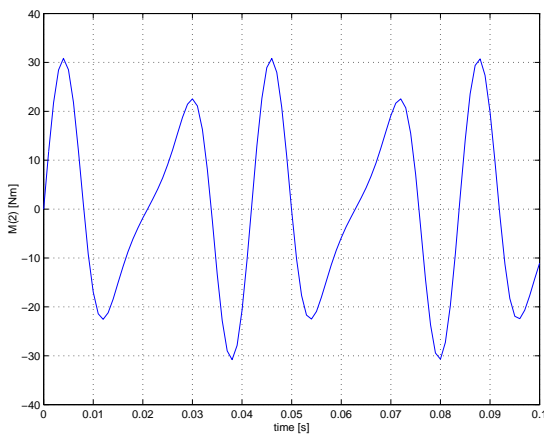
**Figure 3.6.** Case 1: Horizontal position of the sliding block.



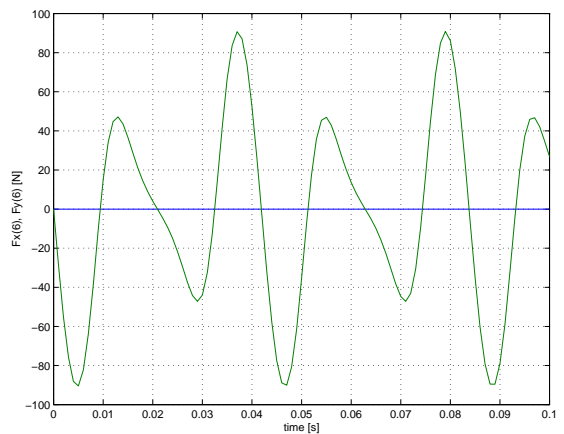
**Figure 3.7.** Case 1: Horizontal velocity of the sliding block.



**Figure 3.8.** Case 1: Horizontal acceleration of the sliding block.



**Figure 3.9.** Case 1: Driving moment in rotational node 2.



**Figure 3.10.** Case 1: Supporting forces on the sliding block.

```

>> plot(time,xdd(:,lnp(6,1)))
>> grid
>> xlabel('time [s]')
>> ylabel('(d/dt)^2 x(6) [m/s^2]')
>>
>> plot(time,fxtot(:,lnp(2,1)))
>> grid
>> xlabel('time [s]')
>> ylabel('M(2) [Nm]')
>>
>> plot(time,fxtot(:,lnp(6,1:2)))
>> grid
>> xlabel('time [s]')
>> ylabel('Fx(6), Fy(6) [N]')

```

## Case 2

The input file of case 1 (page 48) is modified to account for the shortened connecting rod. Only the initial position of node 6 in the second block of the kinematic definition has to be changed:

```

X      6      0.35      0.

```

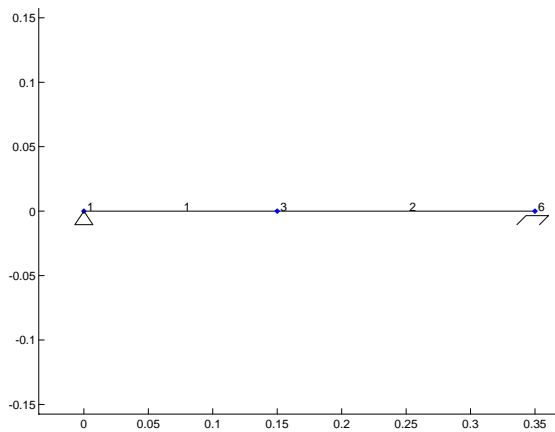
The initial configuration of case 2 is depicted in Fig. 3.11. The horizontal position, velocity and acceleration of the sliding block as a function of time are given in Figs. 3.12–3.14. The driving moment in node 2 versus time is shown in Fig. 3.15 and the supporting forces acting on the sliding block are presented in Fig. 3.16.

The MATLAB commands used to plot these results are identical as in case 1 (page 48).

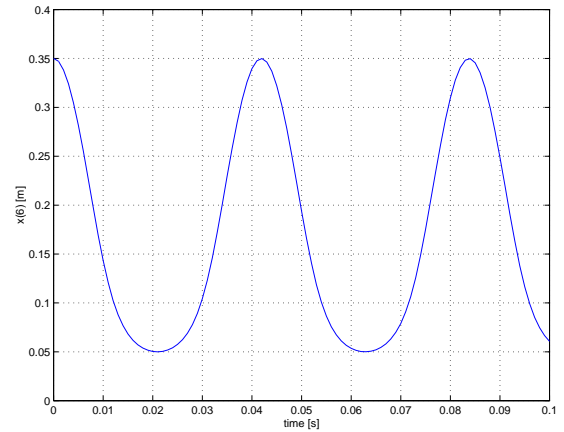
## Case 3

To take the flexibility of the connecting rod into account with a reasonable accuracy the planar beam element used for this rod (see Fig. 3.4) is split into two parts. One translational node and one rotational node are inserted and the numbers of the nodes in the sliding block  $C$  are changed. The bending stiffness of the connecting rod is computed using the moment of inertia  $I = \pi d^4/64$ . The input file (`crankfl.dat`) is now:

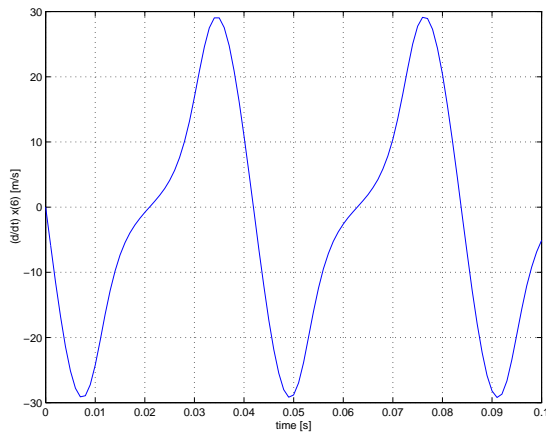




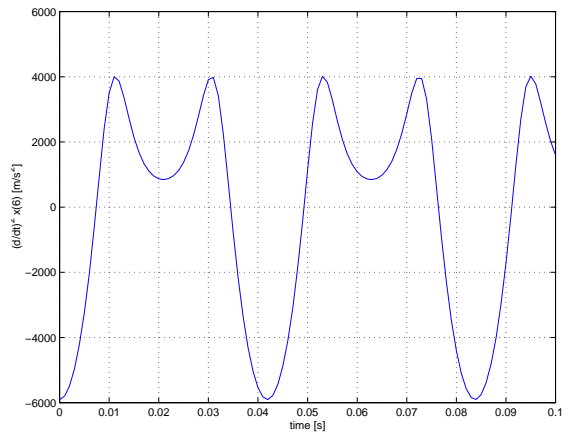
**Figure 3.11.** Case 2: Initial configuration of the slider–crank mechanism.



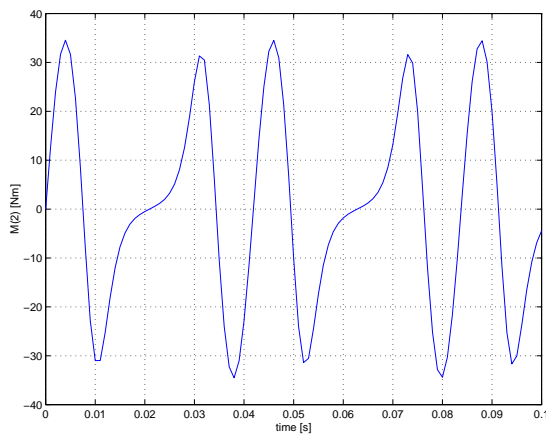
**Figure 3.12.** Case 2: Horizontal position of the sliding block.



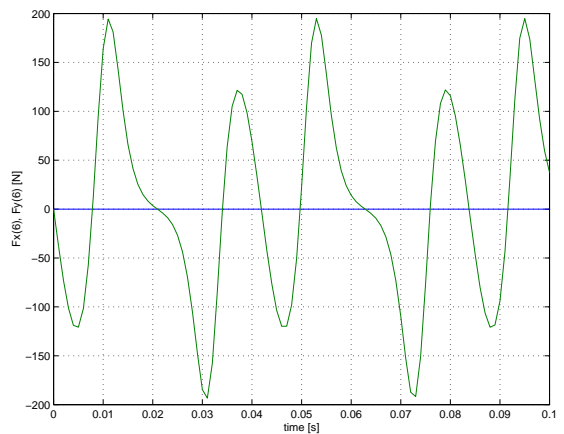
**Figure 3.13.** Case 2: Horizontal velocity of the sliding block.



**Figure 3.14.** Case 2: Horizontal acceleration of the sliding block.



**Figure 3.15.** Case 2: Driving moment in rotational node 2.



**Figure 3.16.** Case 2: Supporting forces on the sliding block.

```

PLBEAM      1   1   2   3   4
PLBEAM      2   3   5   6   7
PLBEAM      3   6   7   8   9

X           1           0.000   0.000
X           3           0.150   0.000
X           6           0.300   0.000
X           8           0.450   0.000

FIX         1
FIX         8   2
INPUTX     2   1
DYNE       2   2   3
DYNE       3   2   3

END
HALT

XM          8           0.033375
EM          2           0.2225
EM          3           0.2225

ESTIFF     2           0.000000  13.359623
ESTIFF     3           0.000000  13.359623

INPUTX     2   1           0.000000  150.000000  0.000000
TIMESTEP   0.100000  100
STARTDE    2   2           0.000000  0.000000
STARTDE    2   3           0.000000  0.000000
STARTDE    3   2           0.000000  0.000000
STARTDE    3   3           0.000000  0.000000

END
END

```

The second-order contributions of the bending deformations on the elongation (Eq. (6.4.22) in the lecture notes) are taken into account.

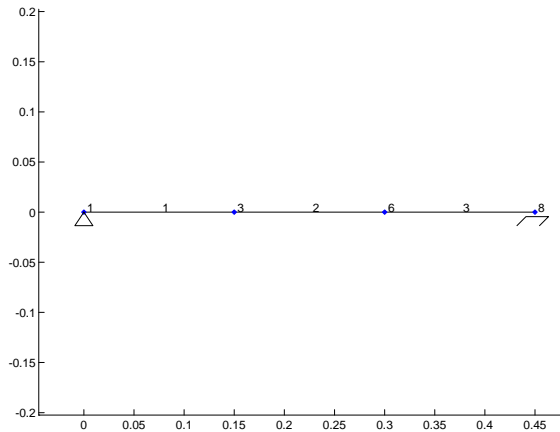
The initial configuration of case 3 is depicted in Fig. 3.17. The horizontal acceleration of the sliding block as function of time is given in Fig. 3.18. The bending of the slider, given by  $v = \frac{1}{2}(\varepsilon_3^{(2)} + \varepsilon_2^{(3)})$ , as function of the crank angle  $\phi^2$ , is presented in Fig. 3.19.

The MATLAB commands used to plot these results are:

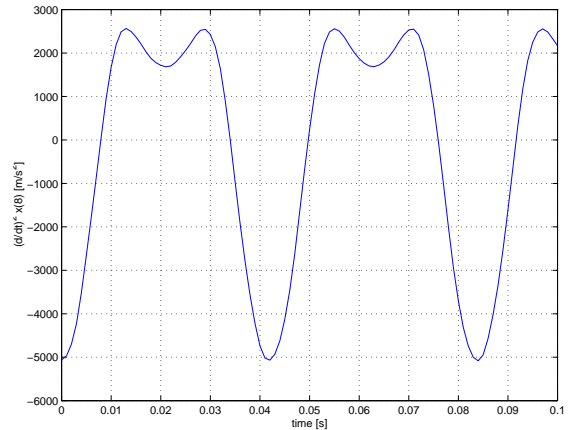
```

>> plot(time,xdd(:,lnp(8,1)))
>> grid
>> xlabel('time [s]')
>> ylabel('(d/dt)^2 x(8) [m/s^2]')
>>

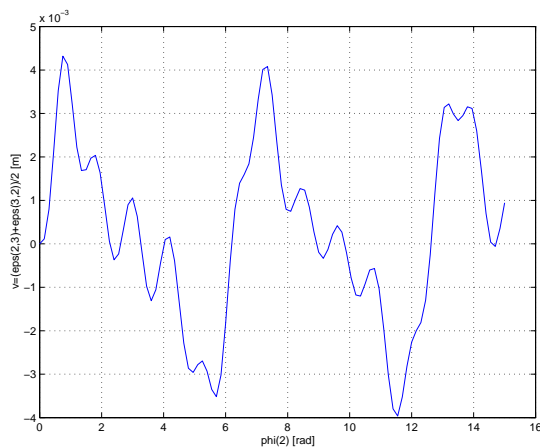
```



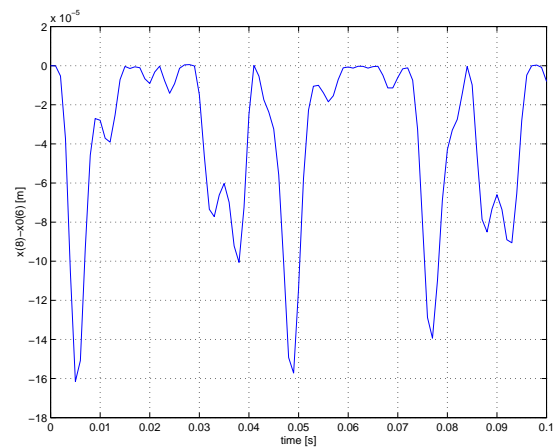
**Figure 3.17.** Case 3: Initial configuration of the slider–crank mechanism.



**Figure 3.18.** Case 3: Horizontal acceleration of the sliding block.



**Figure 3.19.** Case 3: Bending of the flexible connecting rod (elements 2 and 3).



**Figure 3.20.** Case 3: Difference in the horizontal position of the sliding block compared to case 1.

```
>> plot(x(:,lnp(2,1)),(e(:,le(2,3))+e(:,le(3,2)))/2)
>> grid
>> xlabel('phi(2) [rad]')
>> ylabel('v=(eps(2,3)+eps(3,2))/2 [m]')
```

Figure 3.20 shows the (small) vibration of the sliding block due to the bending by comparing its position with the rigid simulation of case 1 (Fig. 3.6).

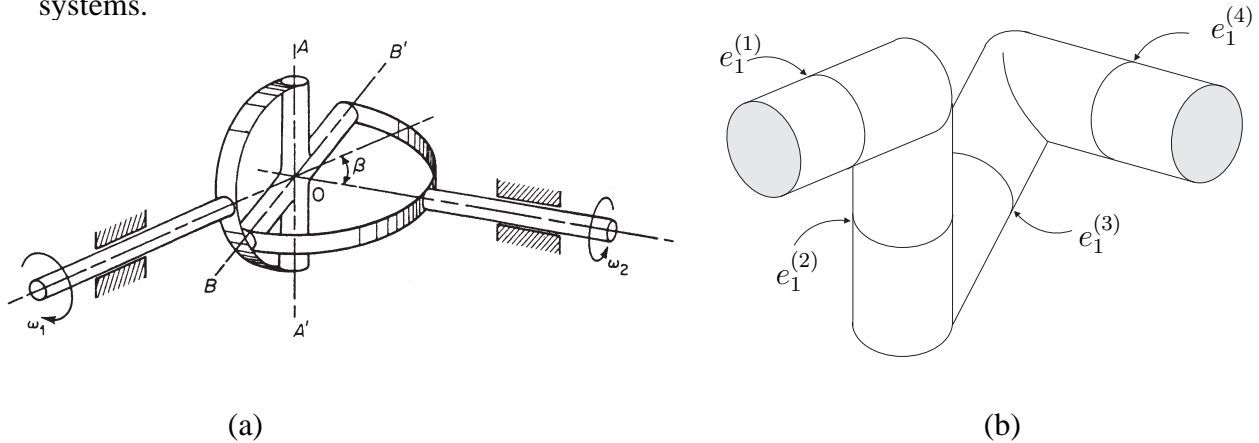
Nodal points for the planar slider-crank mechanism							
	node 1	node 2	node 3	node 4,5,7	node 6	node 8	node 9
node type	T	R	T	R	T	T	R
$x$ -coordinate	0		0.15		0.45	0.30	
$y$ -coordinate	0		0		0	0	
BC-type $x$	1		2		2	2	
BC-type $y$	1		2		1	2	
BC-type $\phi$		3		2			2
$\phi_0$		0					
$\omega_0 = \dot{\phi}$		150					
$\dot{\omega}$		0					
forces/moment	0	0	0	0	0	0	0
mass/inertia	0	0	0	0	0.033	0	0
T=translational, R=rotational, BC=boundary condition							

The numbers of the BC-type refers to the numbers of the groups mentioned on page 17.

Elements for the planar slider-crank mechanism			
	element 1	element 2	element 2a, 3
element type	beam	beam	beam
T-nodes	1, 3	3, 6	3, 8 / 8, 6
R-nodes	2, 4	5, 7	5, 9 / 9, 7
type $e_1$	1	1	1
type $e_2$	1	1	4
$(e_2)_0$			0
$(\dot{e}_2)_0$			0
type $e_3$	1	1	4
mass per length	0.2225	0.2225	0.2225
$EA$	$5.65 \cdot 10^6$	$5.65 \cdot 10^6$	$5.65 \cdot 10^6$
$EI$	13.4	13.4	13.4
damping	0	0	0
T=translational, R=rotational			

### 3.3 Cardan-joint mechanism

In section 11.1 of the lecture notes [1] a cardan joint is described. Cardan joints, also known as Hooke's joints, have been used as a shaft coupling in a wide range of machinery, which includes locomotive as well as automotive drive lines. A drive line connected by a Cardan joint may exhibit torsional oscillations due to fluctuating angular velocity ratios inherent in such systems.



**Figure 3.21.** Schematic of Cardan joint system.

Figure 3.21a shows a one-degree of freedom shaft system incorporating a Cardan joint. The Cardan joint is modelled by four spatial hinge elements as shown in Figure 3.21b. The rotating shaft axes having an angular misalignment of  $\beta = 45^\circ$  is driven at a constant angular speed  $\dot{e}^{(1)} = \Omega_{in}$ . The quantities  $e^{(1)}$  and  $e^{(4)}$  represent the input and output angles of the hinge elements ① and ④, respectively.

The essential behaviour of the joint can be simulated with the following input file (cardansimp.dat):

```
HINGE      1      1      2      -1.      0.      0.
HINGE      2      2      3       0.     -1.      0.
HINGE      3      3      4       0.      0.     -1.
HINGE      4      4      5      0.707 -0.707  0.
```

```
FIX        1
FIX        5
INPUTE     1      1
RLSE       2      1
RLSE       3      1
RLSE       4      1
```

```
END  HALT
```

```
INPUTE     1      1      0.      6.28      0.
TIMESTEP   1.0  100
```

```
END  END
```

Note that in the initial configuration, the input shaft is rotated by a right angle with respect to the configuration in Figure 3.21.

However, the visualization of this simulation is quite poor. This can be improved by adding some beams to the input and output rotational nodes numbers 2 and 4, respectively. The complete input file (`cardan.dat`) becomes:

```

HINGE      1   1   2      -1.    0.    0.
HINGE      2   2   3       0.   -1.    0.
HINGE      3   3   4       0.    0.   -1.
HINGE      4   4   5      0.707 -0.707  0.

BEAM       5   6   2   7   8      0.    1.    0.
BEAM       6   7   8   9  10      0.    1.    0.
BEAM       7   6   4  11  12     0.707  0.707  0.
BEAM       8  11  12  13  14     0.707  0.707  0.

FIX        1
FIX        5
FIX        6

X          6   0.    0.    0.
X          7   1.    0.    0.
X          9   1.    0.    0.15
X         11 -0.707  0.707  0.
X         13 -0.707  0.707  0.15

INPUTE     1   1

RLSE       2   1
RLSE       3   1
RLSE       4   1

END
HALT

INPUTE     1   1   0.   6.28  0.

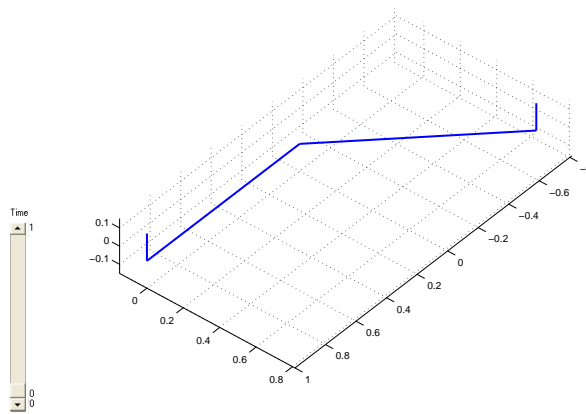
TIMESTEP   1.0 100

END
END

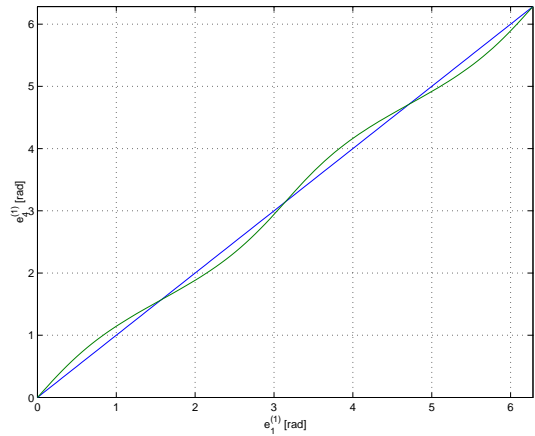
```

The initial configuration of this mechanism is shown in Fig. 3.22. Figures 3.23, 3.24 and 3.25 show the zeroth, first and second order geometric transfer functions from input  $e_1^{(1)}$  to output  $e_1^{(4)}$ , respectively. The MATLAB commands to plot these data are:

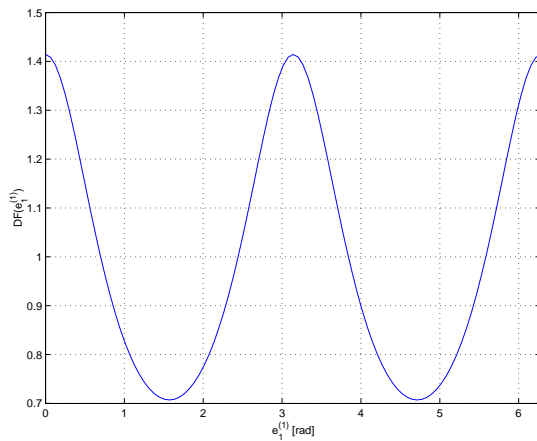
```
>> plot(e(:,le(1,1)),e(:,le(1,1)), e(:,le(1,1)),e(:,le(4,1)))
```



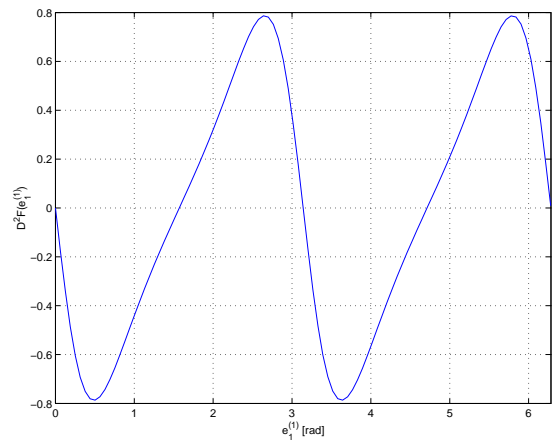
**Figure 3.22.** Initial configuration of the cardan joint.



**Figure 3.23.** Zeroth order geometric transfer function for the cardan joint.



**Figure 3.24.** First order geometric transfer function for the cardan joint.



**Figure 3.25.** Second order geometric transfer function for the cardan joint.

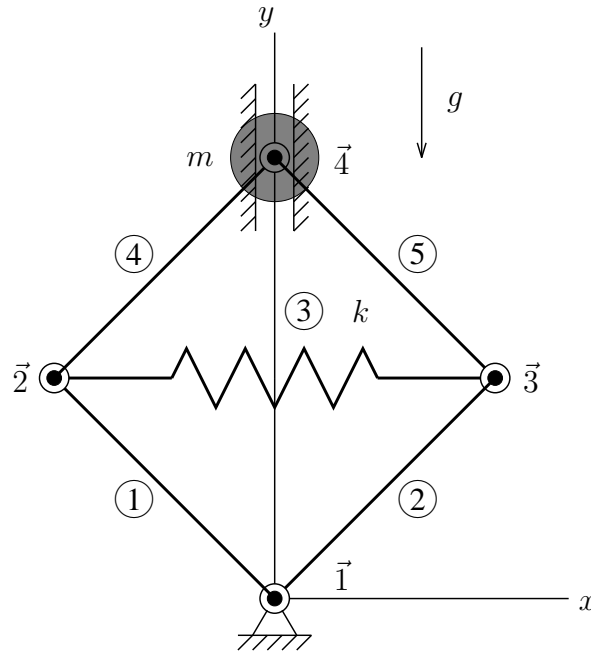
```

>> grid
>> xlabel('e_1^{\{1\}} [rad]')
>> ylabel('e_4^{\{1\}} [rad]')
>>
>> plot(e(:,le(1,1)),ed(:,le(4,1))./ed(:,le(1,1)))
>> grid
>> xlabel('e_1^{\{1\}} [rad]')
>> ylabel('DF(e_1^{\{1\}})')
>>
>> plot(e(:,le(1,1)),edd(:,le(4,1))./(ed(:,le(1,1)).^2))
>> grid
>> xlabel('e_1^{\{1\}} [rad]')
>> ylabel('D^2F(e_1^{\{1\}})')

```

### 3.4 Planar four-bar mechanism

In examples 5.7.1 and 12.4.1 of the lecture notes [1] the planar four-bar mechanism of Fig. 3.26 is analysed analytically. The mechanism has one degree of freedom. The mechanism is modelled by four rigid truss elements, denoted by 1, 2, 4 and 5, which are joined together at their nodal points to form a rhombus. As Fig. 3.26 implies, these four bars are set at right angles



**Figure 3.26.** Four-bar mechanism.

to one another. The diagonal element 3 represents a spring with stiffness  $k = EA/l_0$ . A concentrated mass  $m$  is attached at node 4. The deformation parameter  $e_3$  has been chosen as the generalized coordinate. The equation of motion is

$$m\ddot{e}_3 + \sqrt{2}m(\dot{e}_3)^2 + ke_3 = mg . \quad (3.1)$$

Using the coefficient matrices from the lecture notes, the linearized equation of motion is

$$m\delta\ddot{e}_3 + 2\sqrt{2}m\dot{e}_3\delta\dot{e}_3 + (k - \sqrt{2}mg + 2\sqrt{2}m\ddot{e}_3 + 5m(\dot{e}_3)^2)\delta e_3 = 0 . \quad (3.2)$$

These results can also be obtained numerically from a SPACAR analysis. E.g. with numerical values for  $m = 1$ ,  $g = 10$  and  $k = 1$  and initial conditions  $e_3 = 0$  and  $\dot{e}_3 = 1$  the acceleration is according to Eq. (3.1)  $\ddot{e}_3 = 10 - \sqrt{2} = 8.59$ . A SPACAR input file (fourbar.dat) for this case is:

```

PLTRUSS 1 1 2
PLTRUSS 2 1 3
PLTRUSS 3 2 3
PLTRUSS 4 2 4
PLTRUSS 5 3 4

X      1      0.      0.

```



```

X      2      -0.7071  0.7071
X      3      0.7071  0.7071
X      4      0.      1.4142

FIX    1
FIX    4  1
DYNE   3  1

END
HALT

XM     4      1.
XF     4      0.      -10.
ESTIFF 3      1.4142
STARTDE 3  1  0.      1.

END
END

```

In a MATLAB session we get (the literal text of the session is modified somewhat to get a more compact presentation):

```

>> spacar(1, 'fourbar')
>> e(le(3,1))
ans = 0

>> ed(le(3,1))
ans = 1

>> edd(le(3,1))
ans = 8.5858

```

Substituting the numerical values of the parameters into the linearized equation of motion Eq. (3.2) gives

$$\delta\ddot{e}_3 + 2\sqrt{2}\delta\dot{e}_3 + (1 - 10\sqrt{2} + 2\sqrt{2}(10 - \sqrt{2}) + 5)\delta e_3 = 0, \quad (3.3)$$

or

$$\delta\ddot{e}_3 + 2.83\delta\dot{e}_3 + 16.14\delta e_3 = 0. \quad (3.4)$$

The stiffness term is a combination of

$$\begin{aligned} \mathbf{K}_0 &= k = 1 \\ \mathbf{G}_0 &= \sqrt{2}k e_3 = 0 \\ \mathbf{N}_0 &= \sqrt{2}g + \dot{e}_3)^2 - k/m e_3 = 15.14 \end{aligned} \quad (3.5)$$

where the solution of Eq. 3.1

$$\ddot{e}_3 = g - \sqrt{2}(\dot{e}_3)^2 - k/m e_3 \quad (3.6)$$

has been used. In a MATLAB session we get:

```
>> spacar(4, 'fourbar')  
>> m0  
m0 = 1.0000
```

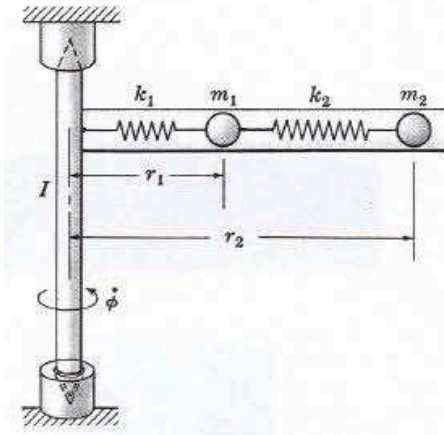
```
>> c0  
c0 = 2.8285
```

```
>> k0  
k0 = 1
```

```
>> n0  
n0 = 15.1423
```

```
>> g0  
g0 = 0
```

### 3.5 Rotating mass–spring system



**Figure 3.27.** Rotating mass–spring system.

Consider the system shown in Fig. 3.27. A smooth horizontal tube containing masses  $m_1$  and  $m_2$  connected with springs  $k_1 = EA_1/l_1$  and  $k_2 = EA_2/l_2$  is mounted on a rotating shaft. The shaft rotates at constant angular speed  $\dot{\phi}$ . The unstretched length of the springs is denoted by  $l_1$  and  $l_2$ . The equations of motion in terms of the generalized coordinates  $r_1$  and  $r_2$  are

$$\begin{bmatrix} m_1 & 0 \\ 0 & m_2 \end{bmatrix} \begin{bmatrix} \ddot{r}_1 \\ \ddot{r}_2 \end{bmatrix} = \begin{bmatrix} m_1 \dot{\phi}^2 r_1 - k_1(r_1 - l_1) + k_2(r_2 - r_1 - l_2) \\ m_2 \dot{\phi}^2 r_2 - k_2(r_2 - r_1 - l_2) \end{bmatrix} \quad (3.7)$$

The stationary solution  $(r_{01}, r_{02})$  is obtained by substituting  $\dot{r}_1 = \dot{r}_2 = \ddot{r}_1 = \ddot{r}_2 = 0$

$$\begin{bmatrix} k_1 + k_2 - m_1 \dot{\phi}^2 & -k_2 \\ -k_2 & k_2 - m_2 \dot{\phi}^2 \end{bmatrix} \begin{bmatrix} r_{01} \\ r_{02} \end{bmatrix} = \begin{bmatrix} k_1 l_1 - k_2 l_2 \\ k_2 l_2 \end{bmatrix}, \quad (3.8)$$

from which the stationary configuration  $(r_{01}, r_{02})$  is obtained analytically as

$$r_{01} = \frac{-(m_2 k_1 l_1 - m_2 k_2 l_2) \dot{\phi}^2 + k_1 k_2 l_1}{m_1 m_2 \dot{\phi}^4 - (k_2 m_2 + k_2 m_1 + k_1 m_2) \dot{\phi}^2 + k_1 k_2} \quad (3.9)$$

$$r_{02} = \frac{-m_1 \dot{\phi}^2 k_2 l_2 + k_1 k_2 (l_1 + l_2)}{m_1 m_2 \dot{\phi}^4 - (k_2 m_2 + k_2 m_1 + k_1 m_2) \dot{\phi}^2 + k_1 k_2} \quad (3.10)$$

This result can also be obtained numerically from a SPACAR analysis. E.g. with the following numerical values:

$$\begin{aligned} l_1 &= 0.10 \text{ m} & k_1 &= 1.3 \text{ kN/m} \\ l_2 &= 0.15 \text{ m} & k_2 &= 0.7 \text{ kN/m} \\ m_1 &= 0.80 \text{ kg} & \dot{\phi} &= 10 \text{ rad/s} \\ m_2 &= 0.50 \text{ kg} & & \end{aligned}$$

A SPACAR input file (massspring.dat) describing this case is :

```

PLBEAM 1 1 2 3 4
PLBEAM 2 3 4 5 6
PLTRUSS 3 1 5

```

```

X 1 0. 0.
X 3 0.1 0.
X 5 0.25 0.

```

```

FIX 1

```

```

INPUTX 2 1
DYNE 1 1
DYNE 3 1

```

```

RLSE 2 1

```

```

END
HALT

```

```

XM 2 1.
XM 3 0.8
XM 5 0.5

```

```

ESTIFF 1 130.
ESTIFF 2 105.

```

```

INPUTX 2 1 0.0 10.0

```

```

END
END

```

In a MATLAB session we find for the stationary configuration  $(r_{01})$  and  $(r_{02})$  in agreement with Eqs. (3.9) and (3.10):

```

>> spacar(7, 'massspring')
>> x(lnp(3,1))

ans =    0.1184

```

```

>> x(lnp(5,1))

```

```

ans =    0.2891

```

The linearized equations of motion in terms of the dynamic degrees of freedom are:

$$\begin{bmatrix} m_1 & 0 \\ 0 & m_2 \end{bmatrix} \begin{bmatrix} \delta \ddot{r}_1 \\ \delta \ddot{r}_2 \end{bmatrix} + \begin{bmatrix} k_1 + k_2 - m_1 \dot{\phi}^2 & -k_2 \\ -k_2 & k_2 - m_2 \dot{\phi}^2 \end{bmatrix} \begin{bmatrix} \delta r_1 \\ \delta r_2 \end{bmatrix} = \begin{bmatrix} 0 \\ 0 \end{bmatrix} \quad (3.11)$$

The associated frequency equation is given by:

$$\det \left( -\omega_i^2 \begin{bmatrix} m_1 & 0 \\ 0 & m_2 \end{bmatrix} + \begin{bmatrix} k_1 + k_2 - m_1 \dot{\phi}^2 & -k_2 \\ -k_2 & k_2 - m_2 \dot{\phi}^2 \end{bmatrix} \right) = 0, \quad (3.12)$$

where the quantities  $\omega_i$  are the natural frequencies of the system. In a MATLAB session we obtain:

```
>> spacar(7, 'massspring')
>> m0

m0 =

    0.8000         0         0    0.5000

>> k0

k0 =

    2000    -700    -700     700

>> n0

n0 =

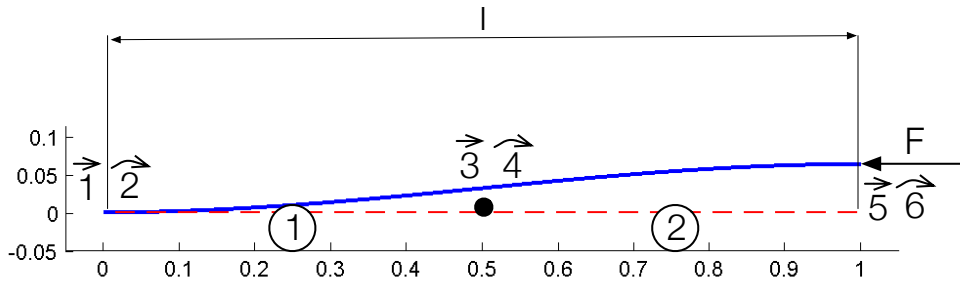
   -80.0000         0   -0.0000  -50.0000
```

The complex eigenvalues and associated eigenvectors can be found in the log file:

```
Complex eigenvalues and normalised eigenvectors of the state-space
system matrix
Notation (real : imaginary)
Eigenvalue numbers 1 to 4
( 0.00000E+00 : +/-5.55511E+01)    ( 0.00000E+00 : +/-2.47806E+01)
Eigenvector numbers 1 to 4
( 0.0141650 : 0.0000000)    ( 0.0177403 : 0.0000000)
( -0.0111041 : 0.0000000)    ( 0.0362089 : 0.0000000)
( 0.0000000 : +/-0.7868804)    ( 0.0000000 : +/-0.4396164)
( 0.0000000 : -/+0.6168430)    ( 0.0000000 : +/-0.8972801)
```

From the eigenvalues numbers in this table we find  $\omega_1 = 24.78$  rad/s and  $\omega_2 = 55.55$  rad/s.

### 3.6 Cantilever beam in Euler buckling



**Figure 3.28.** Cantilever beam loaded axially by a force  $F$  at the free end.

Consider a slender cantilever beam or column, with suppressed rotation of the free end, loaded axially by a force  $F$ . The smallest load that produces buckling is called the critical or Euler load  $F_{cr}$ . For a load equal to or greater than the critical load, the beam is unstable. The bent shape shown represents the buckling mode. Euler's theoretical buckling load for the above beam end conditions is  $F_{th} = \pi^2 EI/l^2$ , where  $EI$  is the flexural rigidity and  $l$  the length of the beam. This result can also be obtained numerically from a SPACAR analysis, e.g. with the following numerical values,  $l = 1$ ,  $EI = 1$ ,  $F_0 = 1$ . The beam is modelled by two equal planar beam elements as shown in Figure 3.28. A SPACAR input file (`column2.dat`) for this case is:

```

PLBEAM 1 1 2 3 4
PLBEAM 2 3 4 5 6

X 1 0.0 0.0
X 3 0.5 0.0
X 5 1.0 0.0

FIX 1
FIX 2
FIX 6

DYNX 3 2
DYNX 4 1
DYNX 5 2
RLSE 1 2 3
RLSE 2 2 3

END
HALT

EM 1 1.
EM 2 1.

```

```
ESTIFF 1 0. 1.
```

```
ESTIFF 2 0. 1.
```

```
XF 5 -1.0 0.0
```

```
END
```

```
END
```

In a MATLAB session we obtain:

```
>> spacar(8,'column2')
```

```
>> edit column2.log
```

```
Load multipliers and normalized buckling modes
```

```
Load multiplier no 1 to 3
```

```
9.94384680E+00 4.00000000E+01 1.28722820E+02
```

```
Buckling mode nro 1 to 3
```

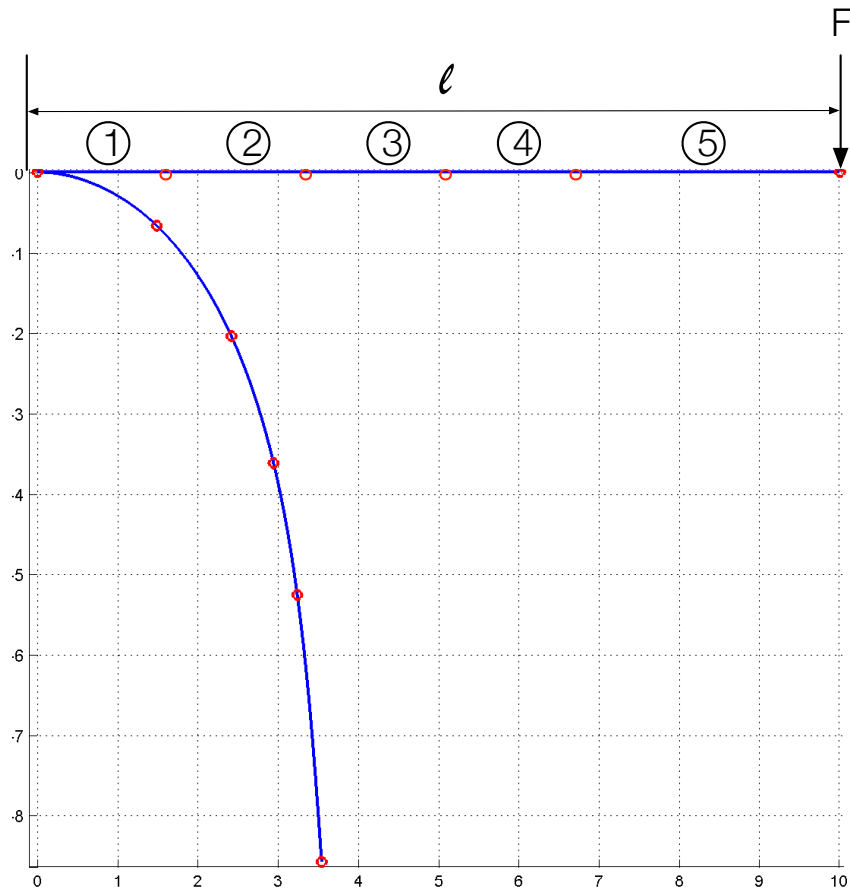
```
0.2596610869 -1.0000000000 -0.0519056301
```

```
0.8141747968 0.0000000000 0.9932416764
```

```
0.5193221738 0.0000000000 -0.1038112603
```

Hence, we find a load multiplier  $\lambda_1 = F_{cr}/F_0 = 9.944$ . Since  $F_0 = 1$  we have  $F_{cr}/F_{th} = 9.944/\pi^2 = 1.0075$ .

### 3.7 Cantilever beam subject to concentrated end force



**Figure 3.29.** Cantilever beam loaded by a concentrated force at the free end.

Consider a slender cantilever beam with a circular cross-section of diameter  $d = 1$  cm and length  $l = 10$  m. The material properties for this example are  $EI = 102 \text{ Nm}^2$ . The beam is subdivided into 5 planar finite elements as shown in Fig. 3.29. A point force  $F$  of 14 N is applied along the vertical axis at the free end of the beam. It generates an elastic deformation as shown in the figure. The deformation is reached in ten steps of loading. For each step the residual vector converges in 4 Newton–Raphson iterations with an accuracy equal to  $0.5\text{E} - 6$ . A SPACAR input file (`plbeam5.dat`) for this case is:

```
PLBEAM 1 1 2 3 4
PLBEAM 2 3 4 5 6
PLBEAM 3 5 6 7 8
PLBEAM 4 7 8 9 10
PLBEAM 5 9 10 11 12
```

```
X 1 0. 0.
X 3 1.666 0.
X 5 3.333 0.
```



```
X 7 5. 0.  
X 9 6.666 0.  
X 11 10.00 0.
```

```
FIX 1  
FIX 2
```

```
DYNE 1 2 3  
DYNE 2 2 3  
DYNE 3 2 3  
DYNE 4 2 3  
DYNE 5 2 3
```

```
END  
HALT
```

```
EM 1 1.  
EM 2 1.  
EM 3 1.  
EM 4 1.  
EM 5 1.
```

```
ESTIFF 1 0.0 102.0  
ESTIFF 2 0.0 102.0  
ESTIFF 3 0.0 102.0  
ESTIFF 4 0.0 102.0  
ESTIFF 5 0.0 102.0
```

```
XF 11 0.0 -14
```

```
END  
END
```

In a MATLAB session we get:

```
>> spacar(8, 'plbeam5')  
  
>> x(lnp(11,1))  
ans =  
    3.5402    (theoretically, 3.8109)  
  
>> x(lnp(11,2))  
ans =  
   -8.5774    (theoretically, -8.4044)  
  
>> xcompl(lnp(11,1))  
ans =
```

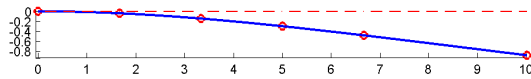
```
0.5111 (undeformed configuration, 0.)
```

```
>> xcompl(lnp(11,2))
```

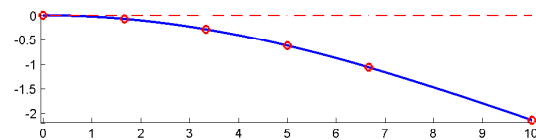
```
ans =
```

```
0.0662 (undeformed configuration, 3.268)
```

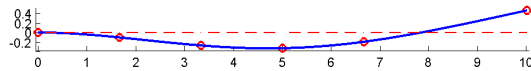
To show the usefulness of SPAVISUAL the first three free vibration modes (no external loads) and buckling modes (axially loaded by an end force) are displayed for the cantilever beam of this example in figures 3.30 to 3.35.



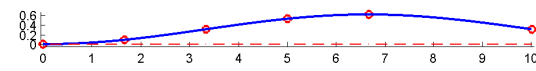
**Figure 3.30.** First vibration mode for a cantilever beam with 5 elements,  $\omega_1 = 0.355131$  rad/s (theoretically, 0.355100 rad/s).



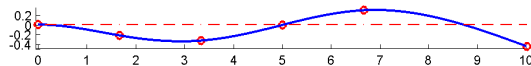
**Figure 3.31.** First buckling mode for a cantilever beam with 5 elements,  $F_{cr1} = 2.516776$  N (theoretically, 2.516749 N).



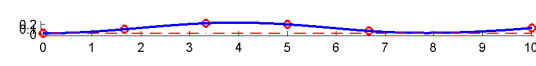
**Figure 3.32.** Second vibration mode for a cantilever beam with 5 elements,  $\omega_2 = 2.2266$  rad/s (theoretically, 2.22537 rad/s).



**Figure 3.33.** Second buckling mode for a cantilever beam with 5 elements,  $F_{cr2} = 22.715$  N (theoretically, 22.651 N).

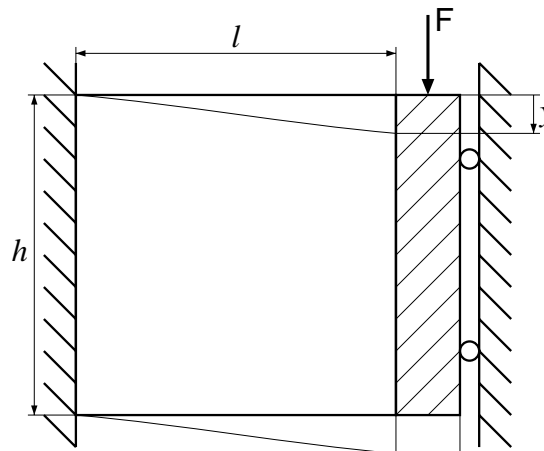


**Figure 3.34.** Third vibration mode for a cantilever beam with 5 elements,  $\omega_3 = 6.25198$  rad/s (theoretically, 6.23111 rad/s).



**Figure 3.35.** Third buckling mode for a cantilever beam with 5 elements,  $F_{cr3} = 64.798$  N (theoretically, 62.919 N).

### 3.8 Short beam



**Figure 3.36.** Short Timoshenko beam loaded in shear.

In this example the influence of shear deformation on the behaviour of short beams is studied. A square plate is loaded in shear in its plane as shown in Figure 3.36. The beam has unit height,  $h$ , length,  $l$ , and Young's modulus,  $E$ , and a small unit width,  $t$ . With Poisson's ratio  $\nu = 0.27$ , the shear correction value is  $k = 10(1 + \nu)/(12 + 11\nu) = 0.8484$ . The deflection, if shear deflection is taken into account, is

$$y = \frac{Fl^3}{12EI} + \frac{2(1 + \nu)Fl}{kEth} \quad (3.13)$$

with  $I = th^3/12$ . So the compliance is

$$\frac{y}{F} = \frac{l^3}{12EI} + \frac{2(1 + \nu)l}{kEth} = 1 + \frac{2(1 + \nu)}{k} = 3.9940. \quad (3.14)$$

The moment of inertia per unit of length is  $J = \rho th^3/12$ .

An input file (shear2.dat) in this case is:

```
PLBEAM 1 1 2 3 4
PLBEAM 2 3 4 5 6
```

```
X 1 0.0 0.0
X 3 0.5 0.0
X 5 1.0 0.0
```

```
FIX 1
FIX 2
FIX 6
FIX 5 1
RLSE 1
RLSE 2
DYNX 3
DYNX 4
```

```

DYNX 5 2

END
HALT

EM 1 1.0 0.0833333333
EM 2 1.0 0.0833333333
ESTIFF 1 1.0 0.0833333333 0.2495
ESTIFF 2 1.0 0.0833333333 0.2495

ITERSTEP 10 1 0.000000000001

END
END

```

In a MATLAB session, the compliances and eigenfrequencies can be found as follows

```

>> spacar(8, 'shear2')
>> xcompl(lnp(5,2))
ans =
    3.9940
>> spacar(7, 'shear2')
>> type shear2.log

...

Eigenvalue numbers 5 to 8
( 0.000000E+00 : +/-2.54107E+00) ( 0.000000E+00 : +/-7.95645E-01)
Eigenvector numbers 5 to 8
( 0.0000000 : 0.0000000) ( 0.0000000 : 0.0000000)
( -0.1544078 : 0.0000000) ( 0.4065978 : 0.0000000)
( 0.2825588 : 0.0000000) ( 0.2566711 : 0.0000000)
( 0.1744141 : 0.0000000) ( 0.6173727 : 0.0000000)
( 0.0000000 : 0.0000000) ( 0.0000000 : 0.0000000)
( 0.0000000 : -/+0.3923612) ( 0.0000000 : +/-0.3235074)
( 0.0000000 : +/-0.7180016) ( 0.0000000 : +/-0.2042190)
( 0.0000000 : +/-0.4431985) ( 0.0000000 : +/-0.4912094)

...

```

The compliance based on thin plate theory is 3.8822 m/N, so the approximation with a short beam overrates the compliance by about 3%. If the shear flexibility were not included, the compliance would be 1.0 m/N.

The lowest numerical eigenfrequency,  $\omega_1 = 0.795645$  rad/s, compares well with a value from plate theory,  $\omega_{1,pl} = 0.7987$  rad/s. If shear flexibility nor rotational inertia is included, the first numerical eigenfrequency is 1.6168 rad/s.

### 3.9 Lateral buckling of cantilever beam

In this example lateral buckling is considered of a cantilever beam with a narrow rectangular cross-section which is loaded by a transverse force  $F_{\text{kip}}$  at its free end in the direction of the larger flexural rigidity. The theoretical buckling load is  $F_{\text{th}} = 4.013\sqrt{(EIS_t)/l^2}$ , where  $EI$  is the smaller flexural rigidity,  $S_t$  the torsional rigidity and  $l$  the length of the beam. For numerical analysis, the beam is divided into four equal spatial beam elements in which the second-order terms in the bending deformations are included in the analysis.

In a MATLAB session we get:

```
>>spacar(8,'lateral4')
>>spavisual('lateral4')
```

An input file (lateral4.dat) describing this case is:

```
BEAM 1 1 2 3 4 0. 1. 0.
BEAM 2 3 4 5 6 0. 1. 0.
BEAM 3 5 6 7 8 0. 1. 0.
BEAM 4 7 8 9 10 0. 1. 0.
```

```
X 1 0.00 0.00 0.00
X 3 0.25 0.00 0.00
X 5 0.50 0.00 0.00
X 7 0.75 0.00 0.00
X 9 1.00 0.00 0.00
```

```
DYNE 1 2 5 6
DYNE 2 2 5 6
DYNE 3 2 5 6
DYNE 4 2 5 6
```

```
FIX 1
FIX 2
```

```
OUTLEVEL 0 1
```

```
END
HALT
```

```
EM 1 1.0 0.0033
EM 2 1.0 0.0033
EM 3 1.0 0.0033
EM 4 1.0 0.0033
```

```
ESTIFF 1 0.0 2.0 0.0 1.0
ESTIFF 2 0.0 2.0 0.0 1.0
ESTIFF 3 0.0 2.0 0.0 1.0
ESTIFF 4 0.0 2.0 0.0 1.0
```

```
XF 9 0.0 0.0 -1.0
```

```
END
```

```
END
```

```
VISUALIZATION
```

```
BUCKLINGMODE 1
```

```
TRANSPERANCY 0.9
```

```
BEAMVIS 0.01 0.1
```

```
LIGHT 1
```

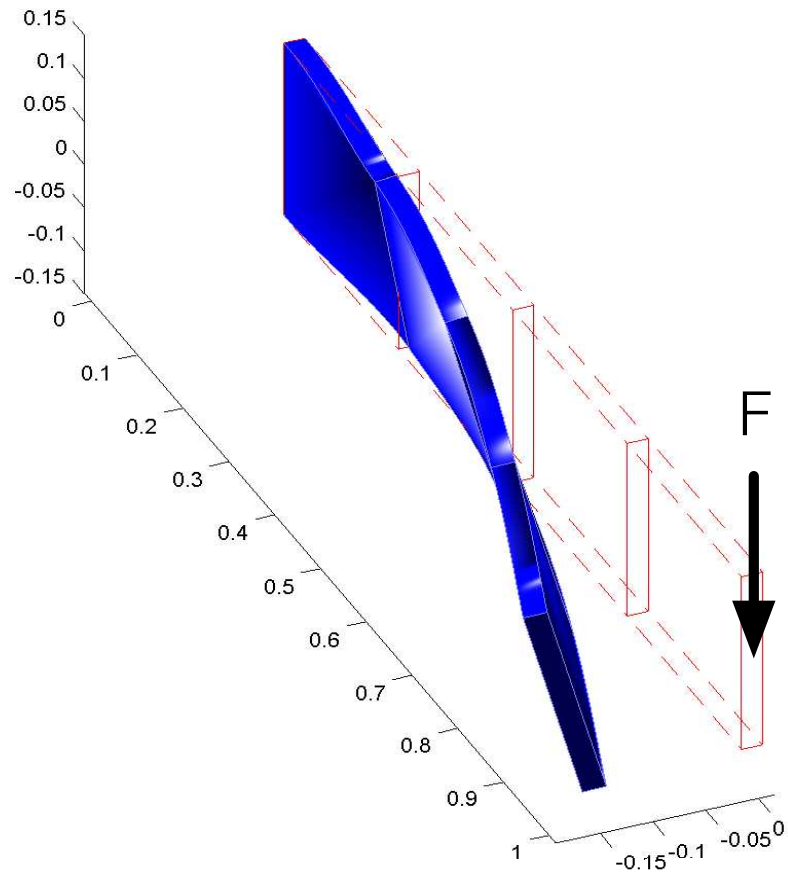
```
STEPLINE 0.01
```

```
ENLARGEFACTOR 0.04
```

The 3D-visualization of this file is presented in figure 3.37. The buckling load found is 5.7619 N, whereas the theoretical value is 5.6752 N. If the warping is constrained at the clamped end, the first element is effectively shorter for torsion by a distance  $b\sqrt{(1+\nu)/24}$ , where  $b$  is the height of the beam, here  $b = 0.2$  m, and  $\nu$  is Poisson's ratio, here  $\nu = 0$ . The torsional stiffness of the first beam element now increases with a factor  $l/(l - b\sqrt{2/3}) = 1.19517$ . The input line for the stiffness of the first beam element now becomes

```
ESTIFF 1 0.0 2.39034 0.0 1.0
```

The critical load is now increased to 6.1694 N.



**Figure 3.37.** Cantilever beam lateral buckling (buckling mode 1).

### 3.10 State-variable and output equations

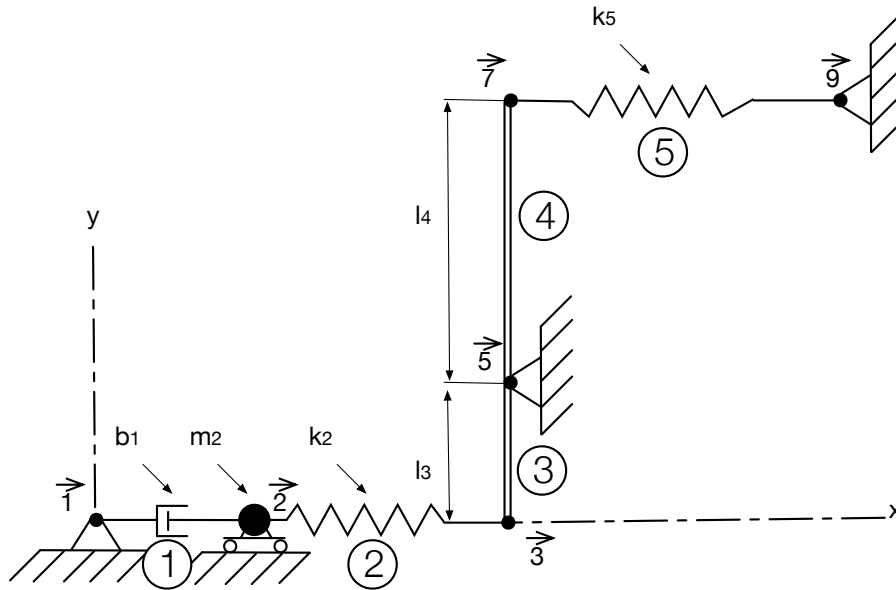


Figure 3.38. Lever system.

Find the state-space-variable and output equations for the system shown in Fig. 3.38.

The input is the displacement  $\delta x^7$  of the left end of spring  $k_2 = EA_2/l_2$ ; it affects the mass  $m_2$  through spring  $k_5 = EA_5/l_5$  and the lever, which is modelled by the planar beam elements 3 and 4. The lever has a fixed pivot at node 5 and is assumed to be massless yet rigid. Its angular orientation is small so that only horizontal motion need be considered. We will select  $\delta x^2$  and  $\delta \dot{x}^2$  as state variables, with  $\delta x^7$  being the input and reaction force  $\delta f_x^5$  as output. With these definitions the state variable and output equations are then:

$$\begin{bmatrix} \delta \dot{x}^2 \\ \delta \ddot{x}^2 \end{bmatrix} = \underbrace{\begin{bmatrix} 0 & 1 \\ -k_2/m_2 & -b_1/m_2 \end{bmatrix}}_A \begin{bmatrix} \delta x^2 \\ \delta \dot{x}^2 \end{bmatrix} + \underbrace{\begin{bmatrix} 0 \\ -(k_2/m_2)(l_4/l_3) \end{bmatrix}}_B [\delta x^7] \quad (3.15)$$

$$[\delta f_x^5] = \underbrace{\begin{bmatrix} -k_2(1 + l_3/l_4) & | & 0 \end{bmatrix}}_C \begin{bmatrix} \delta x^2 \\ \delta \dot{x}^2 \end{bmatrix} + \underbrace{\begin{bmatrix} -k_2 l_3/l_4(1 + l_3/l_4) \end{bmatrix}}_D [\delta x^7], \quad (3.16)$$

which have the desired form. These results can also be obtained numerically from a SPACAR analysis. E.g. with numerical values for  $m_2 = 1$ ,  $b_1 = E_d A_1/l_1 = 5$ ,  $k_2 = k_5 = 1000$  and  $l_4/l_3 = 2$ . A SPACAR input file (lever.dat) for this case is:

```
PLTRUSS 1 1 2
PLTRUSS 2 2 3
PLBEAM 3 3 4 5 6
PLBEAM 4 5 6 7 8
PLTRUSS 5 7 9
```

```
X 1 0.0 0.0
```



```
X 2 1.0 0.0
X 3 2.0 0.0
X 5 2.0 2.0
X 7 2.0 3.0
X 9 3.0 3.0
```

```
FIX 1
FIX 2 2
FIX 5
FIX 9
```

```
DYNX 2 1
INPUTX 7 1
RLSE 1 1
RLSE 2 1
RLSE 5 1
```

```
END
HALT
```

```
XM 2 1.0
```

```
ESTIFF 2 1000.
ESTIFF 5 1000.
EDAMP 1 5
```

```
END
HALT
```

```
INX 1 7 1
OUTF 1 5 1
```

```
END
END
```

In a MATLAB session we get:

```
>> spacar(9,'lever')
>> A=getfrsbf('lever.ltv', 'A', 1)
```

```
A =
```

```
          0          1
      -1000         -5
```

```
>> B=getfrsbf('lever.ltv', 'B', 1)
```

B =

```
      0
     -2000
```

```
>> C=getfrsbf('lever.ltv', 'C', 1)
```

C =

```
     -3000      0
```

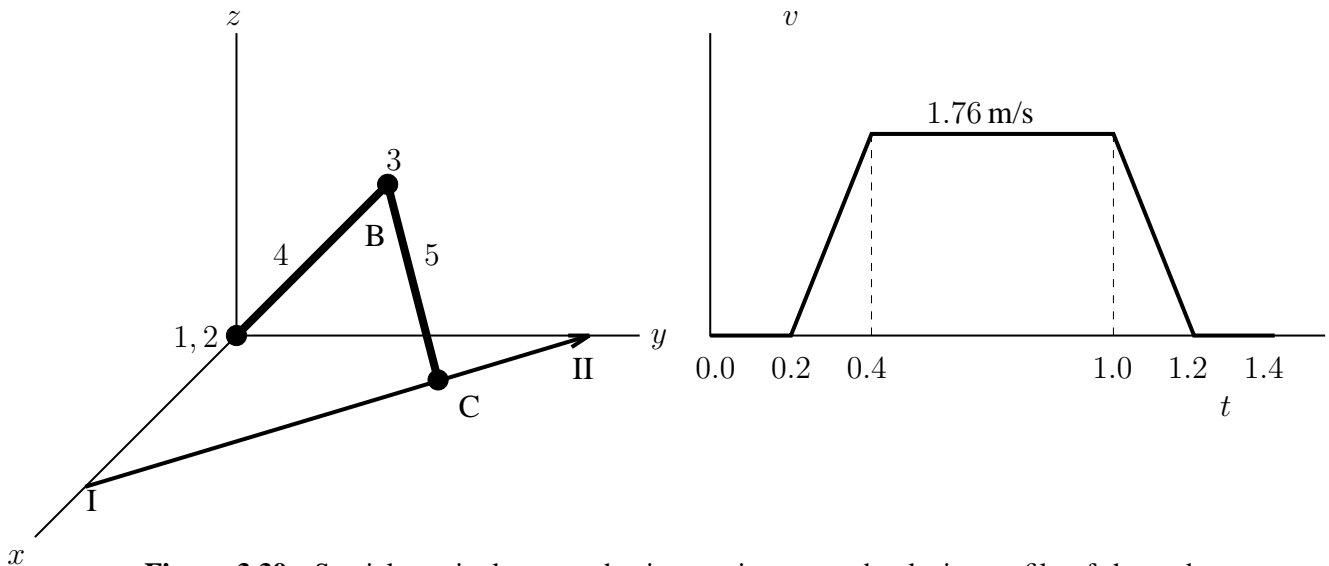
```
>> D=getfrsbf('lever.ltv', 'D', 1)
```

D =

```
     -6000
```

### 3.11 Rigid spatial manipulator mechanism

Figure 3.39 gives an example of a simplified manipulator. The prescribed motion of the end-effector  $C$  is represented by the coordinates  $x^C$ ,  $y^C$  and  $z^C$  as functions of time.



**Figure 3.39.** Spatial manipulator mechanism, trajectory and velocity profile of the end-effector.

The end-effector must follow the straight trajectory from point I to point II. Three trajectories are distinguished: Initially the manipulator is at rest for 0.2 s. Next during 1.0 s the motion is carried out according to the velocity profile in Fig. 3.39 with constant acceleration and deceleration during the first and final 0.2 s. Finally the manipulator is at rest again.

The motion of manipulator is determined by the rotation of three hinges. Hinge 1 enables rotations about the  $z$ -axis, while hinge 2 enables motions perpendicular to the  $xy$ -plane. Hinge 3 takes care of motions in the same plane wherein hinge 2 is active. The hinges are driven by internal actuators. For control purposes we assume that sensors are available that measure the rotations and the speed of rotation of the hinges.

The manipulator consists of two beams, elements 4 and 5, which are equal in length:  $l_4 = l_5 = 0.7$  m. The distributed mass per length is  $\rho_4 = 4$  kg/m for element 4 and  $\rho_5 = 2$  kg/m for element 5. The concentrated masses in nodes  $B$  and  $C$  are 10 kg and 30 kg respectively. The effect of gravity is accounted for by applying external forces  $m_i g$  in negative  $z$ -direction, where  $g = 10$  m/s<sup>2</sup>.

#### Inverse dynamics problem

First the inverse dynamics problem is analysed. Figure 3.43 shows the velocity components of the end-effector that are computed for the trajectory defined in the input file. The position and acceleration components of the end-effector are shown Fig. 3.42 and Fig. 3.44, respectively.

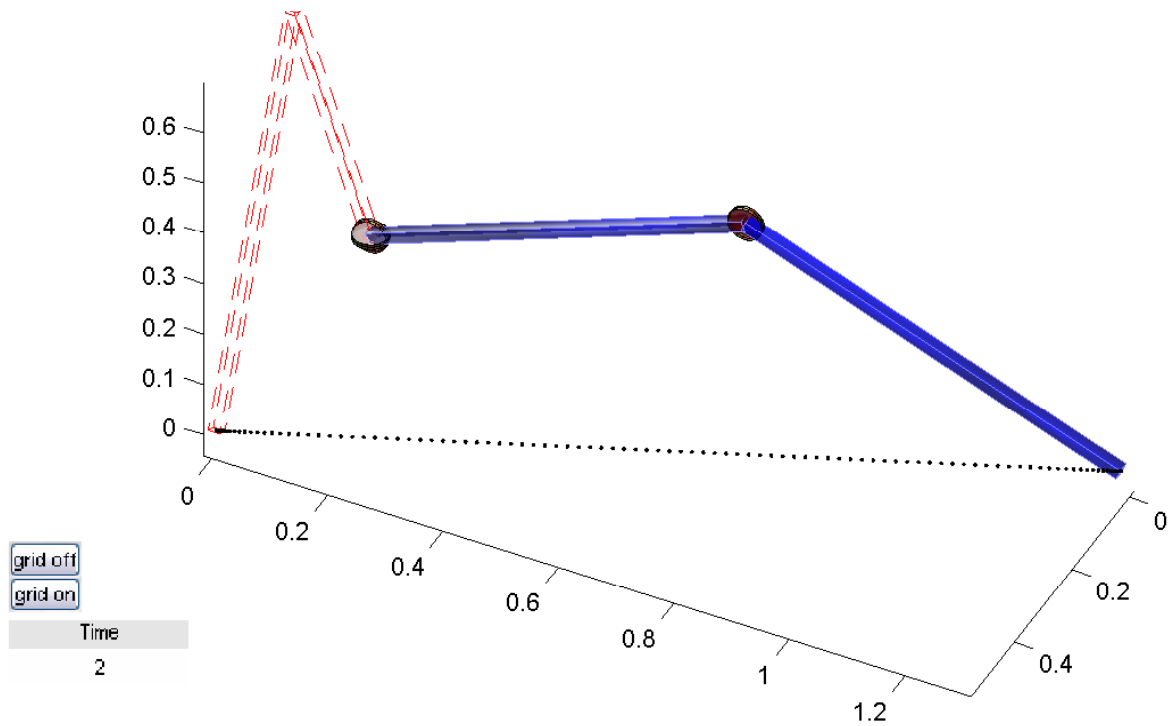
The following input file (`robotinv.dat`) is used (SPACAR mode=2):

```

HINGE  1 1 2      0 0 1      TRAJECT 3
HINGE  2 2 3      0 -1 0     TRANS   8 0.    1.3  0.
BEAM   4 4 3 5 6    0 1 0     TRTIME 0.2 20
HINGE  3 6 7      0 -1 0
BEAM   5 5 7 8 9   0 1 0     NOMS   1 1 1
                                     NOMS   2 2 1
                                     NOMS   3 3 1
X      4 0.      0. 0.
X      5 0.268 0. 0.6467
X      8 0.536 0. 0.
FIX     1
FIX     4
INPUTX 8 1
INPUTX 8 2
INPUTX 8 3
RLSE   1 1
RLSE   2 1
RLSE   3 1
END
HALT
XM     5 10.
XM     8 30.
EM     4 4.
EM     5 2.
XF     1 0.    0. -14.
XF     5 0.    0. -121.
XF     8 0.    0. -307.
END
HALT
TRAJECT 1
TRANS   8 0.536 0.    0.
TRTIME 0.2 20
TRAJECT 2
TRANS   8 0.    1.3  0.
TRVMAX 8 0.2 1.76
TRFRONT 8 0.
TRTIME 1.0 100
TRAJECT 3
TRANS   8 0.    1.3  0.
TRTIME 0.2 20
NOMS   1 1 1
NOMS   2 2 1
NOMS   3 3 1
REFE   1 1 1
REFE   2 2 1
REFE   3 3 1
REFEP  4 1 1
REFEP  5 2 1
REFEP  6 3 1
REFEDP 7 1 1
REFEDP 8 2 1
REFEDP 9 3 1
REFX   10 8 1
REFX   11 8 2
REFX   12 8 3
REFXP  13 8 1
REFXP  14 8 2
REFXP  15 8 3
END
END
VISUALIZATION
BEAMVIS 0.01 0.01
HINGEVIS 1 0.01 0.03
HINGEVIS 2 0.01 0.03
HINGEVIS 3 0.01 0.03
LIGHT 1
TRANSPARENCY 0.6
TRAJECT 1
TRAJECTNODE 8

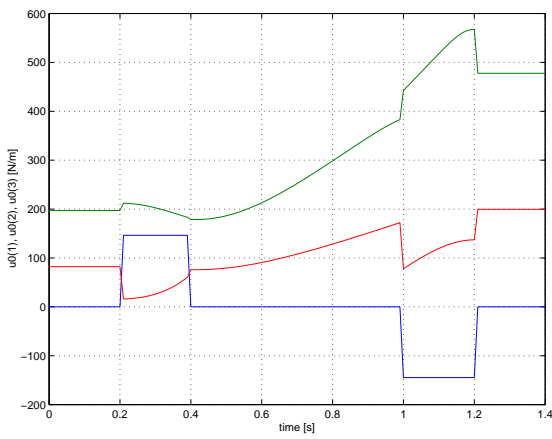
```

The inverse dynamics analysis yields the stresses that have to be applied at the hinges and the deformations of the hinges. Fig. 3.41 shows the stresses. Figures 3.45 and 3.46 show the deformations which are the relative rotations of the hinges, and the first time derivatives, respectively. Clearly, to accomplish the quite simple trajectory of the end-effector of this non-

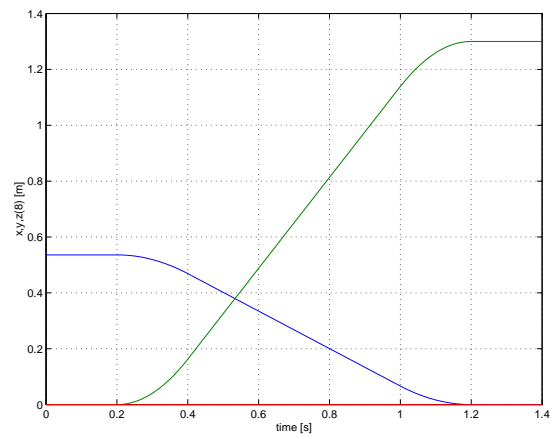


**Figure 3.40.** SPAVISUAL output for the spatial manipulator mechanism.

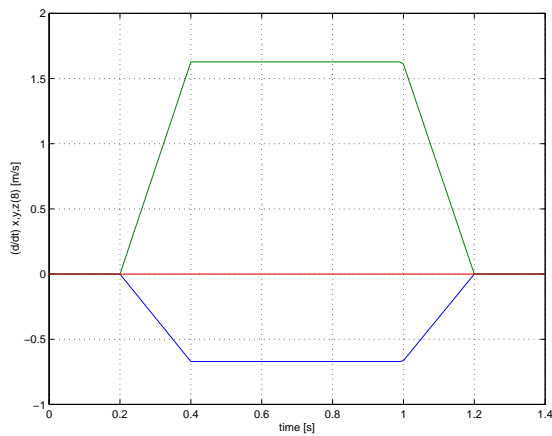
linear mechanism rather complicated functions for the rotation of the hinges are needed. Note that the input files defines the inputs and outputs that will be used in a SIMULINK simulation. The nominal inputs are computed to accomplish the deformations of the hinges. The outputs include the six sensor signals with the rotations and the speed of rotation of the hinges. Nine more outputs are defined to obtain extra information on the performance of the manipulator: the acceleration of the rotation of the hinges and position and velocity of the end-effector. At the end of the file visualization settings for SPAVISUAL are defined. In figure 3.40 the output of SPAVISUAL is presented.



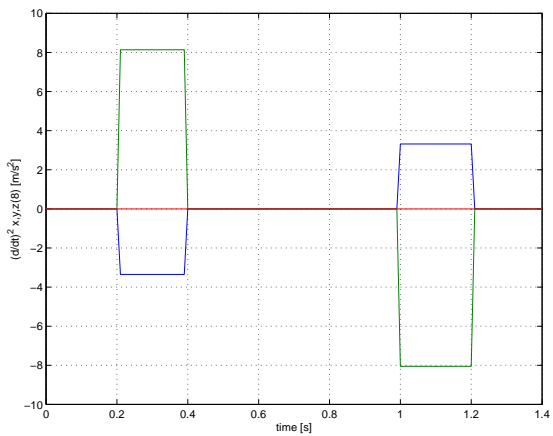
**Figure 3.41.** Stresses to be applied at the hinges ( $u_0$ ).



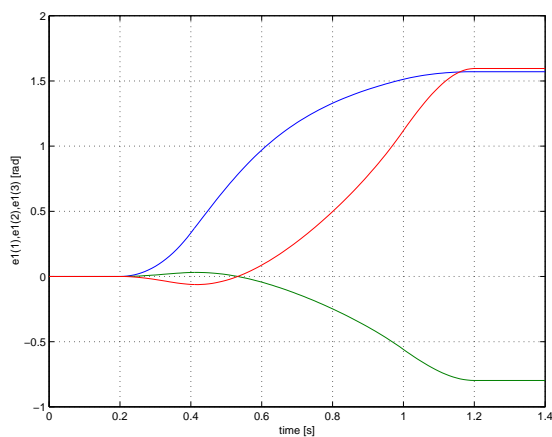
**Figure 3.42.** Position coordinates of the end-effector.



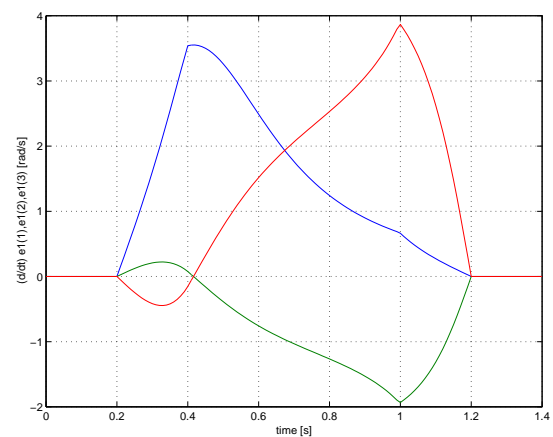
**Figure 3.43.** Velocity components of the end-effector.



**Figure 3.44.** Acceleration components of the end-effector.



**Figure 3.45.** Deformations (relative rotations) of hinges 1, 2 and 3.



**Figure 3.46.** Velocities of deformation of hinges 1, 2 and 3.

Rotational nodes for the spatial manipulator						
	node 1	node 2	node 3	node 6	node 7	node 9
type	2	2	2	2	2	2
$\lambda_0$	2	2	2	2	2	2
$\lambda_1$	1	2	2	2	2	2
$\lambda_2$	1	2	2	2	2	2
$\lambda_3$	1	2	2	2	2	2
forces	0	0	0	0	0	0
$I_{**}$	0	0	0	0	0	0

Translational nodes for the spatial manipulator			
	node 4	node 5	node 8
type	1	1	1
$x$ -coordinate	0	0.268	0.536
$y$ -coordinate	0	0	0
$z$ -coordinate	0	0.647	0
BC-type $x$	1	2	3
$x_0$			0.536
$\dot{x}_0$			0
BC-type $y$	1	2	3
$y_0$			0
$\dot{y}_0$			0
BC-type $z$	1	2	3
$z_0$			0
$\dot{z}_0$			0
force $x$	0	0	0
force $y$	0	0	0
force $z$ (*)	-14	-121	-307
mass	0	10	30
(*) including the element masses			

Elements for the spatial manipulator					
	element 1	element 2	element 3	element 4	element 5
element type	hinge	hinge	hinge	beam	beam
T-nodes				4, 5	5, 8
R-nodes	1, 2	2, 3	6, 7	3, 6	7, 9
$x$ local $y$ -axis	0	0	0	0	0
$y$ local $y$ -axis	0	-1	-1	1	1
$z$ local $z$ -axis	1	0	0	0	0
type $e_1$	2	2	2	1	1
type $e_2$	1	1	1	1	1
type $e_3$	1	1	1	1	1
type $e_4$				1	1
type $e_5$				1	1
type $e_6$				1	1
T=translational, R=rotational					

## Linearization

In one of the next sections the design of a closed-loop controller for this manipulator will be discussed. This controller depends on parameters derived from the linearized equations of motion. Therefore, a linearization is needed in terms of the DOF's corresponding to the actuator joints. An input file (`robotinvlin.dat`) for this analysis (SPACAR mode=3) is:

```

HINGE  1 1 2      0 0 1      NOMS   1 1 1
HINGE  2 2 3      0 -1 0     NOMS   2 2 1
BEAM   4 4 3 5 6   0 1 0     NOMS   3 3 1
HINGE  3 6 7      0 -1 0
BEAM   5 5 7 8 9   0 1 0     REFE   1 1 1
                                     REFE   2 2 1
X      4  0.      0.  0.     REFE   3 3 1
X      5  0.268  0.  0.6467  REFEP  4 1 1
X      8  0.536  0.  0.     REFEP  5 2 1
                                     REFEP  6 3 1
FIX     1                                     REFEDP 7 1 1
FIX     4                                     REFEDP 8 2 1
INPUTE 1 1                                     REFEDP 9 3 1
INPUTE 2 1                                     REFEX  10 8 1
INPUTE 3 1                                     REFEX  11 8 2
                                     REFEX  12 8 3
END                                             REFEXP 13 8 1
HALT                                          REFEXP 14 8 2
                                     REFEXP 15 8 3
XM     5  10.
XM     8  30.
EM     4  4.
EM     5  2.
XF     1  0.      0.  -14.
XF     5  0.      0.  -121.
XF     8  0.      0.  -307.

END
HALT

```

Note that the setpoints are read from the `sbd` data file of which the name is the longest substring of the name of the input file name `robotinvlin`. The file from the previous inverse dynamics run `robotinv` is a likely candidate.



## Open-loop simulation

The behaviour of the manipulator mechanism without feed-back control is simulated using SIMULINK for the open-loop configuration of Fig. 3.47. Two blocks from the SPACAR library `spacar_lib` are used to read the `Setpoint U0` and `Reference Y0` data, respectively, from the inverse dynamics run (file name `robotinv`). In this open-loop configuration the nominal input is fed directly into the SPASIM block (also available in the library). In the input file `robotsim` for this block the actual inputs and outputs are identical to the previously defined inputs and outputs.

```

HINGE  1 1 2      0 0 1      INPUTS 1 1 1
HINGE  2 2 3      0 -1 0     INPUTS 2 2 1
BEAM   4 4 3 5 6   0 1 0     INPUTS 3 3 1
HINGE  3 6 7      0 -1 0     OUTE   1 1 1
BEAM   5 5 7 8 9   0 1 0     OUTE   2 2 1
                                OUTE   3 3 1
X      4 0.      0. 0.      OUTEP  4 1 1
X      5 0.268 0. 0.6467    OUTEP  5 2 1
X      8 0.536 0. 0.      OUTEP  6 3 1
                                OutedP  7 1 1
                                OutedP  8 2 1
                                OutedP  9 3 1
FIX     1
FIX     4
DYNE   1 1
DYNE   2 1
DYNE   3 1
                                OUTX   10 8 1
                                OUTX   11 8 2
                                OUTX   12 8 3
                                OUTXP  13 8 1
                                OUTXP  14 8 2
                                OUTXP  15 8 3
END
HALT

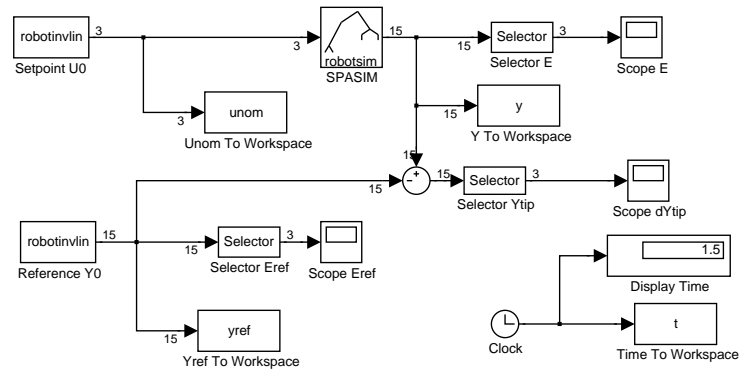
XM     5 10.
XM     8 30.
EM     4 4.
EM     5 2.
XF     1 0.      0. -14.
XF     5 0.      0. -121.
XF     8 0.      0. -307.

END
HALT

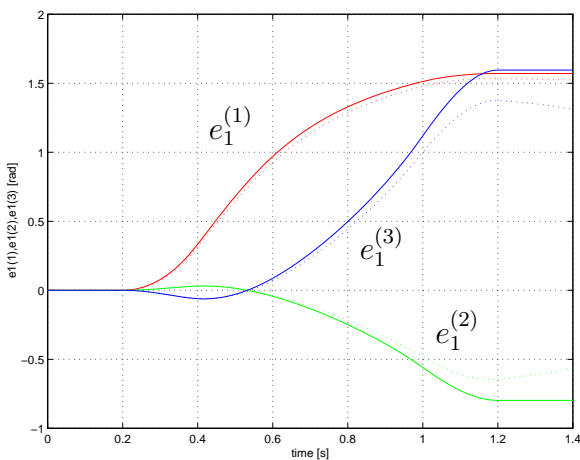
```

The other blocks in the block diagram are standard SIMULINK blocks and are used to export data to workspace and to display results on the screen. The “Selector” blocks select only specified components from an input vector. They are e.g. used to select only the first three components of the output vector (deformations of the hinges) as displaying all components makes the graphs unreadable.

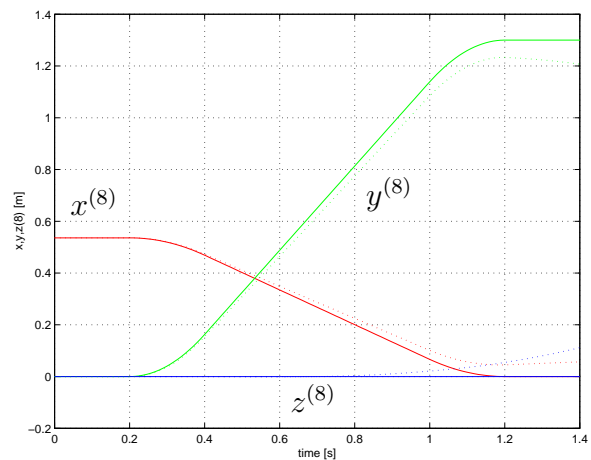
SIMULINK’s `ode45` solver is used with a relative tolerance of  $10^{-5}$ , an absolute tolerance of  $10^{-8}$  and a maximum time step of 0.01 s. With these parameters the simulation of the motion from  $t = 0.0$  s to  $t = 1.5$  s is completed after 172 time steps. The size of many time steps is



**Figure 3.47.** Block diagram for an open-loop simulation of the motion of the manipulator mechanism using SIMULINK.



**Figure 3.48.** Deformation of the hinges of spatial manipulator mechanism in an open-loop simulation.



**Figure 3.49.** Position of the end-effector of spatial manipulator mechanism in an open-loop simulation.

dictated by the specified maximum value.

The results from the simulation are plotted using the MATLAB commands;

```
>> plot(t,yref(:,1),'r',t,yref(:,2),'g',...
        t,yref(:,3),'b',t,y(:,1),'r:',...
        t,y(:,2),'g:',t,y(:,3),'b:')
>> plot(t,yref(:,10),'r',t,yref(:,11),'g',...
        t,yref(:,12),'b',t,y(:,10),'r:',...
        t,y(:,11),'g:',t,y(:,12),'b:')
```

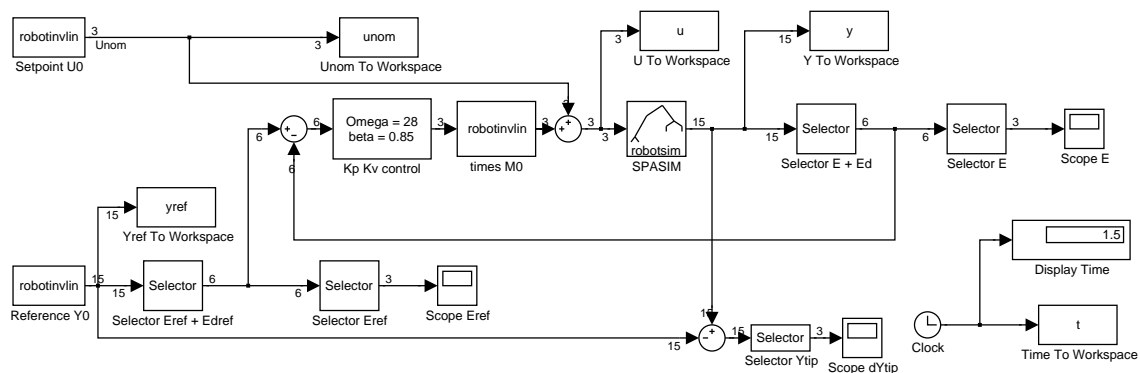
Figures 3.48 and 3.49 show the deformation of the hinges and the position coordinates of the end-effector from this simulation. The solid lines are the reference data ( $y_{ref}$ ) and the dotted lines are from the actual simulation ( $y$ ). Clearly, small errors during the integration lead to relatively large position errors at the end of the motion. The error can be decreased by increasing the integration accuracy, e.g. by enlarging the number of computed setpoints. More reliable results can be obtained by applying feedback control, as will be discussed next.

## Closed-loop simulation

The block diagram of Fig. 3.47 is extended with a feedback controller as shown in Fig. 3.50. A feedback signal is computed by a controller that is implemented as a subsystem block and a multiplication with the reduced mass matrix  $M_0$ . The subsystem assumes that the input is a vector with both  $\delta e$  and  $\delta \dot{e}$ . These are the differences in joint positions and velocities which are computed by comparing the actual motion and the nominal output. The output of the subsystem is

$$K_p \delta e + K_v \delta \dot{e}$$

with well chosen matrices  $K_p$  and  $K_v$  (see e.g. the lecture notes [1]). This output is multiplied with the time-dependent  $3 \times 3$  reduced mass matrix  $M_0$  using a block from the `spacar_lib` library. Finally the nominal input vector  $u_0$  is added as a feedforward signal.

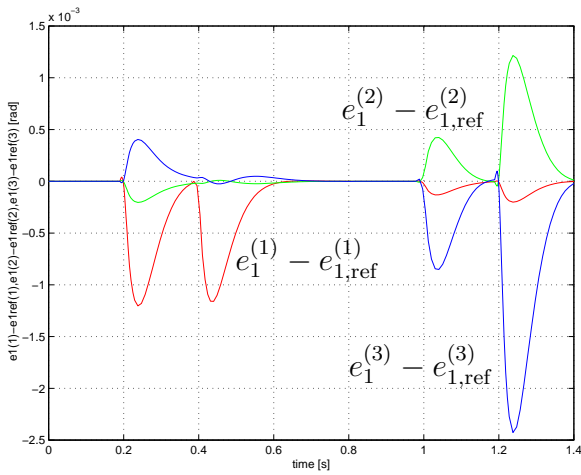


**Figure 3.50.** Block diagram for a closed-loop simulation of the motion of the manipulator mechanism using SIMULINK. Most signals are vectors and the numbers indicate the size of the vectors.

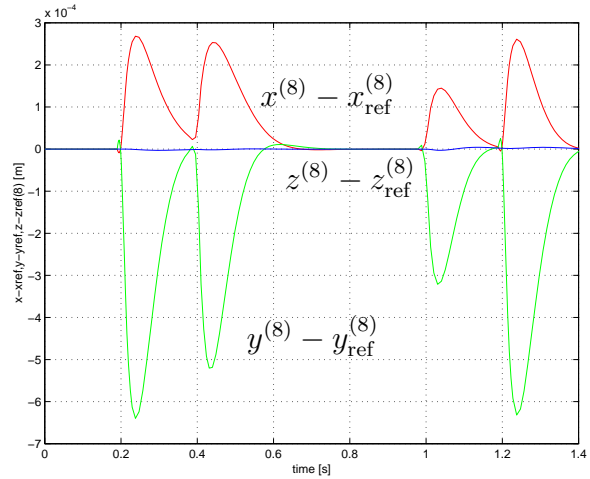
The motion is simulated with the same parameters as in the open-loop simulation (see page 83). In this case the actual size of the variable time step is somewhat smaller and after 183 time steps the simulation is completed. The differences between the prescribed and actual trajectory is much smaller in this case as is illustrated in Figs. 3.51 and 3.52. The maximum error of the tip position is less than 1 mm which is better than 0.1%.

Figs. 3.53 and 3.54 show the feedforward part ( $u_0$ ) and feedback part ( $u - u_0$ ) of the input applied to the manipulator, respectively. Clearly, the larger contribution is from the feedforward part. The size of the feedback part is smaller and relatively large correction are only applied during limited periods of time. However, as is clear from this example, this feedback is essential to keep the manipulator on track.

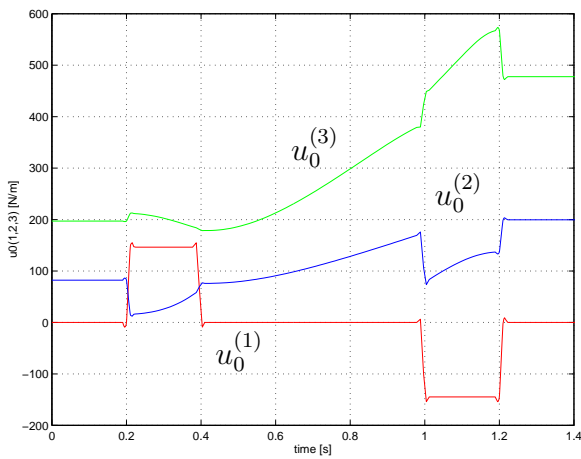
The simulation for 1.5 s now requires 182 time steps, which is only slightly more than in the open-loop simulation. However, the simulation takes much more time which is caused by the occurrence of a so-called algebraic loop in the block diagram. The reason for this algebraic loop is the presence of the joint accelerations in the output vector of the `spasim` block, as accelerations depend algebraically on the input torques. These accelerations are only exported to the workspace and are not used in the feedback loop so there is no real algebraic loop. Unfortunately, SIMULINK has no means to detect this. If you are not interested in the accelerations, they can easily be removed from the output vector and the simulation speed will increase significantly.



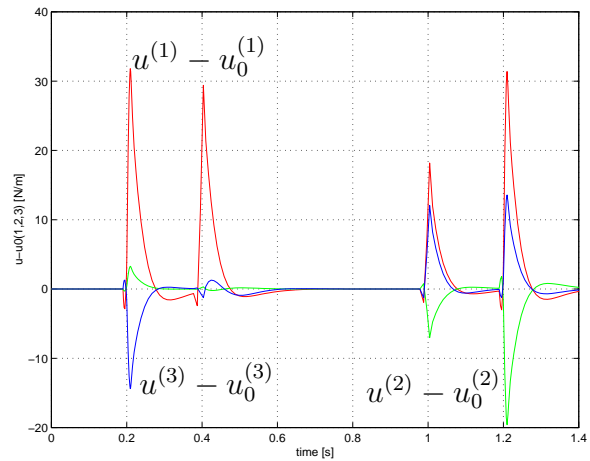
**Figure 3.51.** Error in the deformation of the hinges of spatial manipulator mechanism in a closed-loop simulation.



**Figure 3.52.** Position error of the end-effector of spatial manipulator mechanism in a closed-loop simulation.



**Figure 3.53.** Input applied to the manipulator: feedforward part ( $u_0$ ).



**Figure 3.54.** Input applied to the manipulator: feedback part ( $u - u_0$ ).

## **3.12 Flexible spatial manipulator mechanism**

To be added ...



# SPACAR installation

## Prerequisites

Before installing SPACAR on a computer system it is advisable to check that the system is suitable of running the software and to have MATLAB installed.

This SPACAR version has been developed and tested with MATLAB 7.0.4 and SIMULINK 6.2 (Release 14SP2). It is expected to work with any modern version of MATLAB/SIMULINK since R12, but in case of problems we can offer only limited support.

The system requirements depend heavily on the version of MATLAB you are using. Consult the accompanying Installation Guide or check The Mathworks. You may expect that SPACAR will run on any Microsoft 32-bit Windows PC on which MATLAB/SIMULINK are running. Only the base systems of MATLAB and SIMULINK are required to run SPACAR, but additional toolboxes like the Control System Toolbox may be helpful to develop and analyse control systems.

The installation of SPACAR uses less than 4 MB extra disk space.

The SPACAR files are stored in ZIP-archives or, in Microsoft Windows XP, a compressed folder. In Windows XP you can easily open such archives, but of course you may chose to use your favourite unzipper. The ZIP-archives can be downloaded from

<http://www.wa.ctw.utwente.nl/Software/SPACAR/>.

In addition to the software there is a ZIP-archive with the data files that are used for the examples in Chapter 3.

## Installation

First of all, you should create a subdirectory e.g. `\Matlab\Toolbox\Spacar`. Next, you extract the files from the SPACAR software ZIP-archive `spacar2007_bin.zip` into this subdirectory. There are three types of files:

- Files with the extension `.dll` are the actual executables of the SPACAR package. The original SPACAR-code (not provided) is written in C and FORTRAN77, compiled and linked into so-called MEX-modules, that are executables for use within the MATLAB-environment. The following files must exist:

checksbf.dll	combsbd.dll	getfrsbf.dll	loadsbd.dll
loadsbm.dll	ltv.dll	mrltv.dll	repinsbf.dll
spacar.dll	spacntrl.dll	spasim.dll	

- Files with extension `.m` are the MATLAB-files necessary to use the SPACAR program. The following file must exist:

`spadraw.m`

Other `.m`-files provide help text for the MEX-modules. These files are:

checksbf.m	combsbd.m	getfrsbf.m	getss.m
loadsbd.m	loadsbm.m	ltv.m	mrltv.m
repinsbf.m	spacar.m	spacntrl.m	spasim.m

- Files with extension `.mdl` are SIMULINK models. There is only one file which is actually a library from which the SPACAR modules for use in SIMULINK can be copied:

`spacar_lib.mdl`

The (optional) data files from `spadata.zip` can be extracted in a separate working directory. The files in the SPACAR subdirectory should be in the MATLAB path when MATLAB is running. There are two ways to accomplish this:

1. Make sure that the SPACAR subdirectory is the local directory. You can verify this by typing `pwd`. If necessary, change your local directory by typing
 

```
cd \Matlab\Toolbox\Spacar
```

 or whatever directory you chose to store your files.
2. Another possibility is to change the settings of the MATLAB environment by adding the SPACAR subdirectory to the MATLAB path. This modification is either temporary or permanent. The path can be modified from the pulldown menu with `File|Set Path...`, or by using the MATLAB commands `path` or `addpath`.

Now you are ready to run SPACAR in MATLAB and SIMULINK.



## B

# SPACAR error messages

An analysis with SPACAR in MATLAB or a simulation with SPASIM in SIMULINK can suffer from errors. These errors can be divided into fatal errors that cause an immediate terminations and less severe errors which may report unexpected conditions in the log file, while the calculation continues.

Most fatal error have a clear error message:

- SPACAR requires 2 or 3 input arguments,  
SPACAR requires no output argument,  
CCONST must be 1 x N or N x 1 vector,  
CCONST contains too many parameters,  
MODE has an invalid value and  
FILENAME contains illegal characters  
indicate an incorrect call of SPACAR from MATLAB. The last error can also occur in SPASIM (SIMULINK).
- Wrong number of input arguments,  
Flag must be a scalar variable,  
Too many output arguments,  
Time must be a scalar variable,  
State vector of wrong size,  
Input vector of wrong size and  
Not a valid flag number  
indicate an incorrect call of SPASIM from SIMULINK and should not occur during normal operation.
- ERROR opening file ... means that SPACAR can not open the specified file for output.
- ERROR opening existing file ... means that a file from a previous run is not found.
- ERROR in subroutine DINVOE is caused by an error in the dynamics input, see Sect. 2.3.

- PREPTR: Illegal velocity profile is reported when no valid velocity profile can be determined.
- Can not determine valid and existing input file names from ... means that no mode=2 output data file with extension sbd matching the current (mode=3) data file can be found.
- Mechanisms are different,  
Configuration mismatch LE and  
Configuration mismatch LNP  
arise from an error during the comparison between a the configuration used in a (previous) mode=2 run and the current mode=3 run.
- ERROR in subroutine ORDE0: IFLAG = 2 and  
ERROR in subroutine ORDE0: No convergence  
indicate problems with the zeroth order iteration. In SPASIM this may be avoided by setting or decreasing the maximum time step of SIMULINK's solver.
- ERROR in subroutine SOLDYN is usually caused by a singular mass matrix.
- PRPARE: NUMBER OF NXC NOT EQUAL TO NEO+NEM is caused by an ill-defined mechanism.
- ERROR in subroutine PRPARE: Too many ... means that the mechanism that is defined is too large to be handled by the SPACAR version you are using, see Table 1.1 on page 9. Simplify the mechanism or contact the authors.

The messages written to the log file may be self-explanatory, but also a somewhat cryptic messages "ERROR OR POSSIBLE ERROR CODED: <code> ITEM: <number>" can occur. The <code> is related to a procedure in the software. Typical examples are:

- INVOER<sub>i</sub> input for the kinematics (Sect. 2.2).
- SINVOER<sub>i</sub> input for the inverse dynamics (setpoint generation) (Sect. 2.4).
- LIMVOE<sub>i</sub> input for the linearization (Sect. 2.5).
- SIMVOE<sub>i</sub> input for the non-linear simulation of manipulator control (Sect. 2.6).
- PREPTR. . trajectory data processing.

Note that errors in the input file are often reported one line later than the actual error position.

# MATLAB tutorial

## C.1 Basic MATLAB graphics commands

MATLAB provides a variety of functions for displaying data. This section describes some of these functions. For a complete survey of graphics functions available in MATLAB we refer to the official MATLAB documentation [2] or to the online help utility.

### Elementary plotting functions

The following list summarizes the functions that produce basic line plots of data. These functions differ only in the way they scale the plot axes. Each accepts input in the form of vectors or matrices and automatically scales the axes to accommodate the input data.

- `plot` – creates a plot of vectors or columns of matrices.
- `loglog` – creates a plot using logarithmic scales for both axes.
- `semilogx` – creates a plot using a logarithmic scale for the  $x$ -axis and a linear scale for the  $y$ -axis.
- `semilogy` – creates a plot using a linear scale for the  $x$ -axis and a logarithmic scale for the  $y$ -axis.

You can add titles, axis labels, grid lines, and text to your graph using

- `title` – adds a title to the graph.
- `xlabel` – adds a label to the  $x$ -axis.
- `ylabel` – adds a label to the  $y$ -axis.
- `text` – displays a text string at a specified location.
- `gtext` – places text on the graph using the mouse.
- `grid` – turns on/off grid lines.

## Creating a plot

If  $y$  is a vector, `plot(y)` produces a linear graph of the elements of  $y$  versus the index of the elements of  $y$ . If you specify two vectors as arguments, `plot(x,y)` produces a graph of  $y$  versus  $x$ .

## Line styles, markers, and color

You can pass a character string as an argument to the `plot` function in order to specify various line styles, plot symbols, and colors. In the statement

```
plot(x,y,s)
```

$s$  is a 1-, 2-, or 3-character string (delineated by single quotes) constructed from the characters in the following table:

Symbol	Color	Symbol	Linestyle
y	yellow	.	point
m	magenta	o	circle
c	cyan	x	x-mark
r	red	+	plus
g	green	*	star
b	blue	-	solid
w	white	:	dotted
k	black	-.	dashdot
		--	dashed

For example, `plot(x,y,'c+')` plots a cyan plus symbol at each data point.

If you do not specify a color, the `plot` function automatically uses the colors in the above table. For one line, the default is yellow because this is the most visible color on a black background. For multiple lines, the `plot` function cycles through the first six colors in the table.

## Adding lines to an existing graph

You can add lines to an existing graph using the `hold` command. When you set `hold` to on, MATLAB does not remove the existing lines; instead it adds the new lines to the current axes. It may, however, rescale the axes if the new data fall outside the range of the previous data. For example:

```
plot(f1)
hold on
plot(f2,'--')
plot(f3,'-.')
hold off
```

These statements produce a graph displaying three plots.

## Creating hardcopy of MATLAB figures

You can make a hardcopy of a figure from the figure's menu (`File|Print...`) or by pressing `Ctrl+P`. Output to several graphics formats can be carried out as well (`File|Export...`). Alternatively, MATLAB's `print` command can be used at the MATLAB command prompt. E.g. you can generate PostScript output of the contents the current MATLAB figure window. The `print` command sends the output directly to your default printer or writes it to the specified file, if you supply a filename. You can also specify the type of PostScript file. Supported types include

- PostScript (`-dps`)
- Color PostScript (`-dpSC`)
- Encapsulated PostScript (`-deps`)
- Encapsulated color PostScript (`-depSC`)

For example, the statement

```
print dataplot -deps
```

saves the contents of the current figure window as Encapsulated PostScript in the file called `dataplot.eps`. Depending on your MATLAB installation other graphics formats are supported, try `help print`.

## C.2 Quitting and saving the workspace

To quit MATLAB, type `quit` or `exit`. Terminating a MATLAB session deletes the variables in the workspace. Before quitting, you can save the workspace for later use by typing

```
save
```

This command saves all variables in a file on disk named `matlab.mat`. The next time MATLAB is invoked, you can execute `load` to restore the workspace from `matlab.mat`.

You can use `save` and `load` with other filenames, or to save only selected variables. The command `save temp` stores the current variables in the file named `temp.mat`. The command

```
save temp X
```

saves only variable `X`, while

```
save temp X,Y,Z
```

saves `X`, `Y`, and `Z`.

`load temp` retrieves all the variables from the file named `temp.mat`.



# References

- [1] Jonker, J.B., *Dynamics of Machines and Mechanisms, A Finite Element Approach*, Lecture notes, Department of Mechanical Engineering, University of Twente, vakcode 113130, October 2001.
- [2] The Math Works Inc., *Getting Started with MATLAB*, version 7, Revised for MATLAB 7.1 (Release 14SP3), September 2005.
- [3] The Math Works Inc., SIMULINK — *Getting Started*, version 6, New for SIMULINK 6.3 (Release 14SP3), September 2005.
- [4] SAM, Version 4.2, 5.0 or 5.1, ARTAS - Engineering Software, The Netherlands, <http://www.artas.nl/>, 2001–2005.
- [5] Cowper, G. R., “The shear coefficient in Timoshenko’s beam theory”, *ASME Journal of Applied Mechanics* **33** (1966), pp. 335–340.