

INSTALLATION AND OPERATING INSTRUCTIONS

RayTemp™ Hot Water Energy Management Control

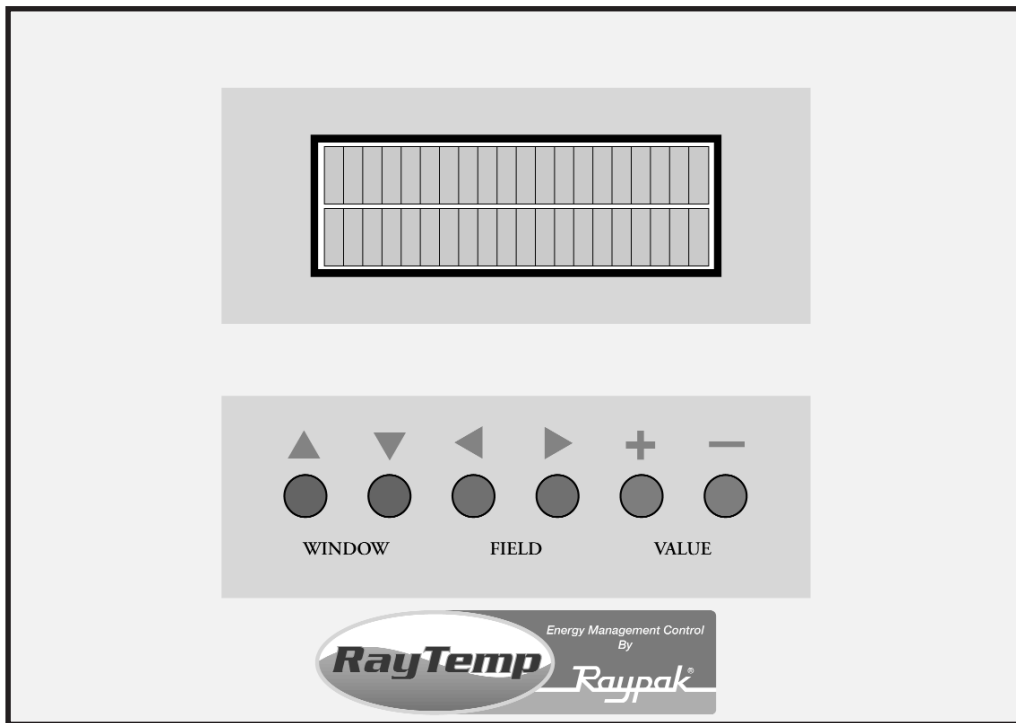

Raypak®

A Rheem® Company

Section 1. GETTING STARTED	3
THE BIG PICTURE	3
WHAT COMES WITH THE CONTROLL	4
Section 2. INSTALLING THE CONTROL	4
ATTACHING THE TEMPERATURE SENSORS	4
PROVIDING 24 VAC POWER TO CONTROL	5
INSTALLATION LAYOUT	6
"DIP" SWITCH SETTINGS ON CIRCUIT BOARD	7
CONNECTING THE OPTIONAL "ELSA" BRAND MODEM	8
USING THE FRONT PANEL TO CHECK SENSORS AND RELAYS	9
Section 3. CONNECTING A COMPUTER (OR "LAPTOP")	10
BUILDING OR BUYING INTERFACE CABLES	10
INSTALLING PTT SOFTWARE ON YOUR PC	11
SIMULATED FRONT PANEL DISPLAY	11
READING LOGGED DATA (Not All Models)	12
USING YOUR PC AND MODEM TO CALL A CONTROL	12
Section 4. PROGRAMMING	14
QUICK REFERENCE	14
FIRST SCREEN AT POWER-UP	17
MANUAL OVERRIDE	17
VIEW SENSORS AND RELAYS	17
TIME AND DATE	17
CELSIUS / FAHRENHEIT SCALE	17
ERASE MEMORY / RESET PROGRAM	18
SECURITY PASSWORD ("G" Models Only)	18
FRONT PANEL MENU / LOCK	18
TIME SCHEDULE	19
SUPPLY TEMPERATURE	19
RETURN TEMPERATURE	21
BRANCH TEMPERATURE	22
RELAY SEQUENCING	22
SENSOR OVERRIDE TEST	23
SAVINGS TEST SETUP	24
SAVINGS TEST RESULTS	24
SENSOR CALIBRATION	25
LOCATION TEXT	26
DATA MODEM SETUP	26
FAX MODEM SETUP AND TEST ("G" Models Only)	27
WARRANTY	29
SERVICE/RETURN AUTHORIZATION PROCEDURE	29

Section 1. GETTING STARTED

THE BIG PICTURE

This RayTemp control is designed to make recirculating domestic hot water heating systems energy efficient. In a recirculating system, hot water is continuously pumped throughout the building. This large loop has many branches which extend to fixtures in the rooms. It is essentially a giant radiator which has tremendous heat loss. By lowering the temperature of this loop it is possible to dramatically reduce this heat loss. The trick is knowing when to lower the temperature without running out of hot water. With RayTemp, water temperatures are automatically scheduled in anticipation of demand. So for the peak demand in the morning, the water is preheated to a higher temperature. The control does this automatically by recording a seven day profile of demand, and then it uses this information to establish setpoints. The control continually adjusts this setpoint to meet demand, always maintaining the lowest temperature which will fully meet user needs. This operation dramatically lessens costly heat loss, lime deposits, and increases the life of the system. The control is preprogrammed with typical settings, making installation very simple. However, the program values can be adjusted to accommodate many types of water heating systems. Output control is provided for up to 4 stages of heat or four heaters. Two standard temperature sensors are connected to the water heating systems at locations called "Supply" and "Return".

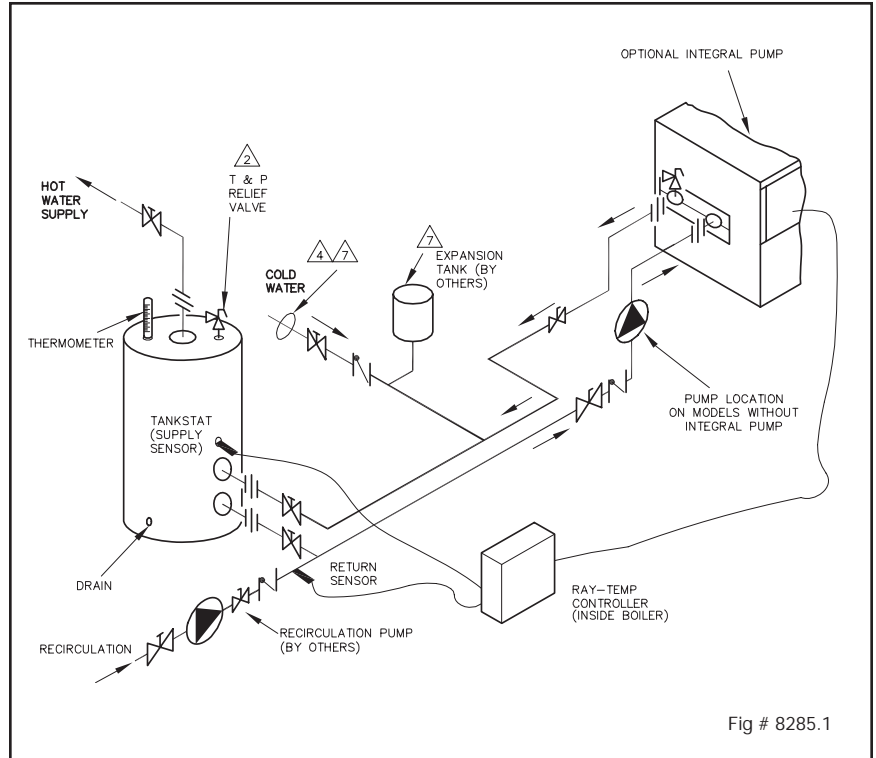

For the peak demand in the morning, the water is preheated to a higher temperature. The control does this automatically by recording a seven day profile of demand, and then it uses this information to establish setpoints. The control continually adjusts this setpoint to meet demand, always maintaining the lowest temperature which will fully meet user needs. This operation dramatically lessens costly heat loss, lime deposits, and increases the life of the system. The control is preprogrammed with typical settings, making installation very simple. However, the program values can be adjusted to accommodate many types of water heating systems. Output control is provided for up to 4 stages of heat or four heaters. Two standard temperature sensors are connected to the water heating systems at locations called "Supply" and "Return".

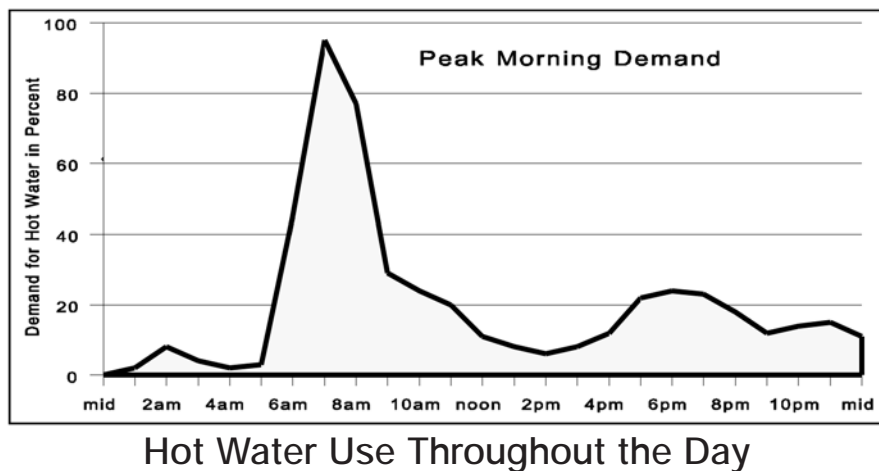

WHAT COMES WITH THE CONTROL

Before arriving at the job site to begin the installation, it's important to first inspect the system and determine what materials you will need. Some parts are included with the control while the others you will need to provide. Check the following list to verify that you received the following parts.

Included in the box	
1 Control, 10.5" x 8" x 3.5"	4 Cable Ties, 15", black, -40°F to 221°F rated
1 Panel Cover, Metal, 4" x 7.5"	2 Knockout Connectors, 1/2" to romex
4 Mounting Screws, 3/4"	1 Warranty Card
2 Temperature Sensors, Copper housing, 10 K Ohm at 25°C	1 Manual
	1 24v Grounded Transformer

Other parts you will need	
Cable, twisted pair with shield, stranded, 18 AWG. Belden type 8208 (braid shield) or 9552 (2 twisted pairs, foil shield)	Cable Ties
Thermal Insulation Tape	Wire Nuts
	Heat Conducting Paste

Section 2. INSTALLING THE CONTROL

The control should be mounted on a wall, preferably at eye level with AC power as close as possible. Consider the length of cable required for routing along walls, along pipes, and for connecting the temperature sensors.

Notice on the bottom of the control that two of the five knockouts have been removed for routing of cables. If you want to use one or more of the other knockouts, these should be removed before mounting the control onto the wall.

ATTACHING THE TEMPERATURE SENSORS

To get an accurate reading of the water temperatures, the sensors must be in good thermal contact with the pipe. Follow this procedure when connecting the temperature sensors.

Procedure for Connecting Temperature Sensors to Pipes:

1. Remove any existing insulation.
2. Clean the pipe surface using sandpaper.
3. Apply thermal conducting paste to the pipe surface.
4. Fasten the sensor tightly to the pipe using the black cable tie.
5. Attach 18 AWG shielded cable to the 6 in. leads using wire nuts or electrical tape.
6. Fasten the cable to the pipe using a second black cable tie.
7. Replace the existing insulation or wrap thermal insulation tape around the pipe.
Overlap each turn and **DO NOT STRETCH** the tape.

On the sensor end, roll the shielding and tape so it will not contact a conductor. On the control end, the shield should be grounded. **Do not ground both ends of the shielding.**

Avoid routing wiring on or near other electrical wires, conduit, motors, spark igniters or other sources of high, intermittent voltage or current. EMI (spikes) can disrupt information flow and retention.

Procedure for Installing Supply Sensor in Tank:

1. Install sensor into dry well utilizing thermal conductive paste.
2. Install dry well into tank stat opening.

PROVIDING 24 VAC POWER TO THE CONTROL

!!! CAUTION !!!
DO NOT connect power until
all wiring is complete
and checked.

!!! CAUTION !!!
DO NOT connect 120 VAC
to the RayTemp!!!
Resulting damage will
void your warranty.

The RayTemp requires an external power transformer connected at terminals one and two. Complete and check all wiring before connecting this transformer. The transformer must be rated for 24 VAC at 16 VA or higher. When 24 VAC power is applied to the control the LCD display will be blank for a few seconds. During this time the RayTemp is configuring any modem that may be connected. After this the opening screen appears which identifies the model number, type of control, software version, and copyright notice.

POWER		RELAY OUTPUTS								SENSOR INPUTS									Comm. Port	
1	2	3	4	5	6	7	8	9	10	11	12	13	14	15	16	17	18	19		20
24 VAC		Stage #1		Stage #2		Stage #3		Stage #4		Supply		Return			P/N 901649					

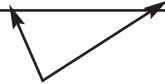
Sensor Connections

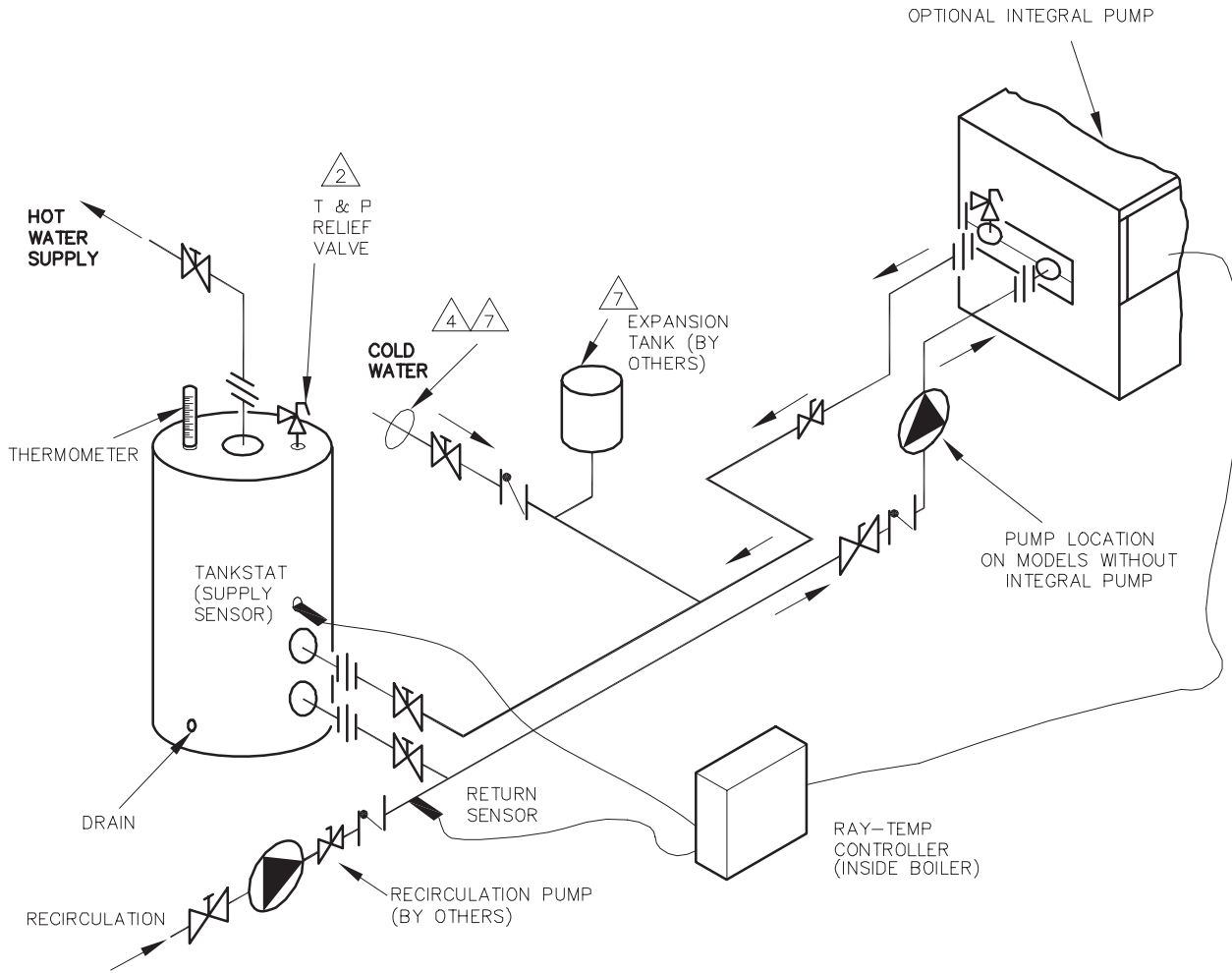

INSTALLATION LAYOUT

KEY	
	PRESSURE RELIEF VALVE
	PUMP
	UNION
	GATE VALVE
	CHECK VALVE
	BALL VALVE
	THERMOMETER

NOTES:

1. PLUMB SWING CHECK VALVE IN GRAVITY-CLOSED POSITION.
2. PIPE ALL RELIEF VALVES TO DRAIN, OR AS LOCAL CODES REQUIRE.
3. LOCATE TEE AS CLOSE AS POSSIBLE TO TANK.
4. INSTALL COLD WATER BETWEEN HEATER OUTLET AND TANK.
5. SEE CHART "MINIMUM PIPE SIZES" FOR MINIMUM PIPE SIZES.
6. SIZING BASED ON HEATER AND TANK BEING PLACED FIVE FEET APART, IF DISTANCE IS GREATER, THE PUMP MUST BE SIZED TO ACCOMMODATE INCREASE IN PIPING RELATED LOSSES.
7. PROVIDE FOR THERMAL EXPANSION OF HOT WATER IF A BACKFLOW PREVENTER, CHECK VALVE, WATER METER OR PRESSURE-REDUCING VALVE IS INSTALLED IN THE COLD WATER LINE.

"DIP" SWITCH SETTINGS ON CIRCUIT BOARD

CAUTION: Incorrect DIP switch settings may damage the RayTemp!!!
Make all adjustments with ALL power off.

The four relay outputs are factory set for normally closed dry contacts. These DIP switches are located behind the terminal block, on the right side. The black dots in the diagram indicate where to set the 20 switches for normally closed dry contacts. As shown, all four outputs will be the same. Relay #1 is set on SW1 positions 6 thru 10. Relay #2 is set on SW1 positions 1 thru 5. Relay #3 is set on SW2 positions 6 thru 10. Relay #4 is set on SW2 positions 1 thru 5.

These switches are factory set and should not need adjustment.

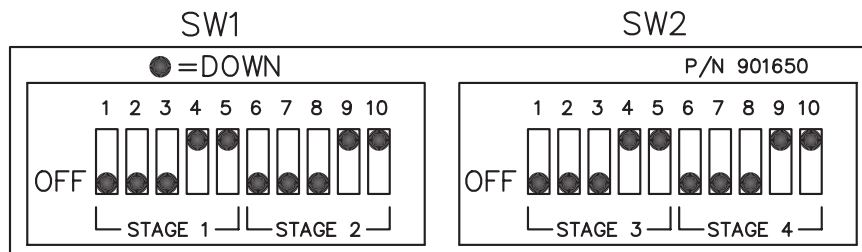

DIP Switch Setting on Circuit Board

The RayTemp can control up to 4 stages:

- Four single-stage heaters
- Two two-stage heaters
- One four-stage heater

2-STAGE

STAGE SELECTOR

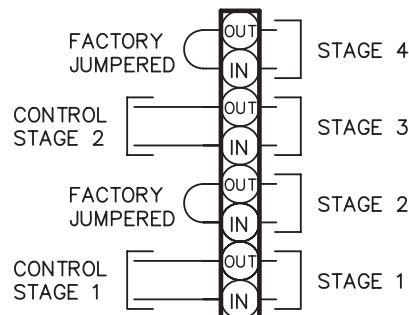

Stage Connections on Heater

Remove factory jumpers for 3- and 4-stage connections.

CONNECTING THE OPTIONAL “ELSA” BRAND MODEM

Raypak recommends the ELSA Microlink 56k modem for data communication. This modem will work with RayTemp and technical support will be provided if this modem is installed with the correct cables. Raypak will not be able to provide support if you use other modem brands or build your own cables. In either case we strongly recommend that you test the RayTemp/modem connection in your office before installing the system. If possible, plan ahead, and have the phone line/jack installed about two feet from the heater. Secure the ELSA modem and connect the phone cable (that comes with the modem) from the wall jack to the ELSA modem jack labeled “Line”. Connect the RayTemp cable 5-423 from the modem’s 8-pin connector to the RayTemp’s “Serial to RJ11” adapter then connect the six-line data cable from the adapter to the RayTemp’s six-pin “RJ11” port (see figure below). Plug in the modem’s power transformer and turn on the power switch. Testing is covered in the next chapter.

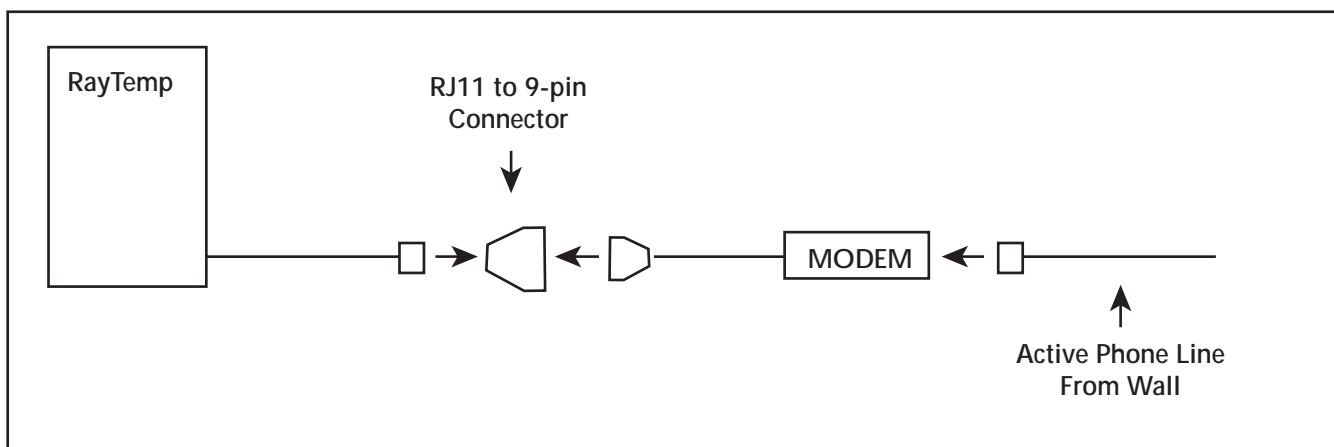

CAUTION!

**DO NOT connect a live phone line directly to the RayTemp control.
Doing so will damage the internal communication circuit!**

USING THE FRONT PANEL TO CHECK SENSORS AND RELAYS

The RayTemp front panel features an alphanumeric LCD display of four rows by 20 lines. Six keys are provided to select screens, fields, and make program changes. The up-arrow and down-arrow "WINDOW" keys are used to step thru each of the screens. The down-arrow screen selects the next screen while the up-arrow key selects the previous screen. The left-arrow and right-arrow "FIELD" keys move a flashing cursor to select different sections within a screen. The plus and minus "VALUE" keys are used to make changes to a selected field or numeric value. Plus increases the selected number or selects the next option. Minus decreases the selected number or selects the previous option.

SE-Sensors	
Supply	136.4
Desired	135.0
Return	128.2

Using the down-"WINDOW" key select the "SENSORS" screen and verify that each temperature sensor is measuring the correct value. It's best to use a reliable temperature reading device, like a surface thermocouple or a digital infrared thermometer. Thermostats and mercury thermometers are frequently inaccurate. If the readings disagree by more than two degrees there may be a problem with how the sensor is attached. Also check for correct wiring at the terminal block.

RT-Relay Status			
#1	#2	#3	#4
ON	OFF	OFF	OFF

Next select the "RELAY STATUS" screen and manually verify that you can turn each water heater or stage on and off. You do this using the field and value keys. If the heater does not turn on it may be necessary to increase the optional secondary mechanical aquastat setting a few degrees. Use a multimeter to troubleshoot if problems persist.

Return to the second screen titled "Master On/Off Mode" and put the control in "Bypass". The water heaters will now run using the optional secondary mechanical aquastats until programming of the control has been completed, explained in the next chapter.

Section 3. CONNECTING A COMPUTER

This section explains how to connect your personal computer to the RayTemp. Once connected, you can view all of the front panel screens covered in the previous section. You can also retrieve the recorded data and view color graphs of temperature and demand profiles. "PTT" is the optional software tool for your personal computers that works with RayTemp controls. It simulates the front panel and retrieves logged data. PTT software and interface cables are available directly from Raypak. The computer must be able to accept a serial (RS-232) cable.

BUILDING OR BUYING INTERFACE CABLES

The following cables are available from Raypak:

Description	Part #
PTT Software Communication for Windows PC to 70 series control	PTT
Direct Connect Communication Cable Connects a 70 series control to a PC	5-424
Modem Communication Cable Connects a 70 series control to a modem	5-423

Wiring pin assignments are provided below for building your own cables.

CAUTION! Never plug a telephone line into the RJ-11 connector! The control may be damaged.

RayTemp to PC/Modem Pin Assignments				
RJ-11 Wire color codes: White = 1 Black = 2 Red = 3 Green = 4 Yellow = 5 Blue = 6	RJ-11 Pin (RayTemp)		DB-9 Pin (PC/Modem)	
	Ground	6	5	Ground
	Program	2	4	Program
	Receive	5	3	Transmit
	Transmit	4	2	Receive

RayTemp to Modem Pin Assignments				
RJ-11 Wire color codes: White = 1 Black = 2 Red = 3 Green = 4 Yellow = 5 Blue = 6	RJ-11 Pin (RayTemp)		DB-25 Pin (Modem)	
	Ground	6	7	Ground
	Receive	5	3	Transmit
	Transmit	4	2	Receive

INSTALLING PTT SOFTWARE ON YOUR PC

This section provides instructions for installing PTT communication software. First insert the PTT CD into your CD drive. Double click on the folder Ptt258 then double click on Install. The PTT communication software will then be installed on your C:\GBX subdirectory. To run PTT, type PTT (then press enter) from the C:\GBX subdirectory. Within a few seconds the main menu, software version I.D., and copyright notice will appear. Use the arrow keys and enter key to select items from the menu bar at the top of the screen. First check the default options by selecting the "Options" menu item. There are several items that can be changed. Most PC's have several communication ports. Port 1 is usually for direct connections and port 2 is usually used for internet modems. The second option sets the communication speed. The default speed for RayTemp is 9600 Baud. Next is the print quality, 1 = draft mode (fast), 2 = medium, 3 = high resolution (but slow). Press Ctrl-Enter to save your selection.

SIMULATED FRONT PANEL DISPLAY

This "Laptop" selection from the menu bar opens up a window on the PC screen to receive formatted data and program information sent by a RayTemp control, connected at the serial (RS232) port. From the main menu select "LapTop" and press enter. Connect the cable to the RayTemp control and press F1 to begin communication. The screen and keyboard will operate similar to the front panel but with enhanced features to take advantage of the larger screen. This table shows the function keys for accessing all RayTemp display and programming features. These keys apply to both the PC and LapTop display, except as noted. A screen saver clears the display after five minutes. Press F1 thru F5 to restore the screen.

Key	Action
F1	Press two keys for direct access to any screen
F2	Select next screen
F3	Select previous screen
F4	Increase program value
F5	Decrease program value
SPACE	Select next field in a screen
BACK SPACE	Select previous field in a screen
F6	Activate full-screen viewing (PC)
SHIFT F6	Restore LapTop window (PC)

READING LOGGED DATA

Under the "History Report" menu item, logged data can be retrieved from a RayTemp control, saved to a disk file, viewed graphically on screen, or output to a printer. To retrieve history, connect the RayTemp serial cable between the RayTemp and your laptop PC. Then select "Retrieve". The RayTemp will transmit logged data to your PC. This takes about one minute at 9600 Baud. A status window will be present while the data is being received. The logged data consists of a report, seven detailed daily graphs (Monday thru Sunday), and twelve monthly graphs (January thru December). A menu will appear from which you can view any of these graphs. This data will be automatically saved to a disk file, based on the file name in the report data. PTT creates a unique name for each file by setting the last position of the file name prefix. The codes are 0 thru 9 and then A thru Z. For examples REDLION.GIX will be saved as REDLION0.GIX, REDLION1.GIX, REDLION2.GIX, etc.

To view an existing history file select "Display", and select a file by pressing enter. After the graphs are prepared, a window will appear from which you can select any daily graph or monthly graph to view on the screen.

The "Print" option under "History Report" allows you to send site reports and graphs to any supported printer. When this item is selected a directory of data files will appear. Point to a file using the arrow keys then press enter to select the file. A check mark will appear. Place check marks next to all data file you wish printed, then press Ctrl-Enter to continue. A second screen will appear for selecting graphs within a report. Place a check mark (press enter) by each graph you want included in the printed report. Press ESC to start printing.

USING YOUR PC, PTT AND MODEM TO CALL A CONTROL

If this is your first attempt at modem communication with a RayTemp control we recommend that you first try everything in your office using two phone lines. Connect the RayTemp to an external modem and connect this modem to one line and your PC modem to another. Next, configure the RayTemps modem as described in the previous section. Make sure that the modem's auto answer "AA" light is on. Also, buy a modem cable from RayTemp - at least for your first installation. This will prevent 80% of your possible problems.

To "get on-line" with the RayTemp, start the PTT software and select "Options" from the menu bar at the top of the screen. Enter the port number (usually 1 or 2) for the modem connected to your PC and make sure the speed is set to 9,600. Then press Ctrl-Enter and select "TechTerm" from the menu bar. A set of seven windows will appear. Start entering the phone set up commands: "ATE1" "ENTER" Return should show "OK". If not, re-enter.

"AT&F" "ENTER" Return should show "OK".

"AT&D0" (zero) "ENTER" Return should show "ok".

For example, to place a call, dial "ATDT5551212" and wait for a "Connect" message (replace the "5551212" with your actual phone number). If the screen is blank, type "ATE1" and try again.

Note: The "Modem" section on the menu bar does not work with the RayTemp. Once you see the "Connect" message in the TechTerm window press F1 and then F6 to begin communication.

To end the modem session, select the following screen in the LapTop window.

**MC-Modem Control
F4 to Hang-Up**

This screen is used to terminate the call. The RayTemp will actually terminate the phone connection and prevent the modem from answering the phone for about five minutes. The message "CARRIER LOST" will appear in the LapTop window. Another call may then be placed to contact another RayTemp sharing the same phone line. Always use this method to end a modem call to the RayTemp in shared phone-line applications. It's also a good idea to have an actual telephone connected to the line. Make sure a dial tone is present to verify that the call has been terminated.

Section 4. PROGRAMMING

QUICK REFERENCE

This section describes all the programmable features of the control. You make program changes from the front panel or by using a laptop. For information on connection with a LapTop using PTT software, refer to the previous section. The following keys provide access to all RayTemp display and programming features. These keys apply to the front panel or LapTop display as shown below. A screen saver clears the display after five minutes on the LapTop. Press F1, then F6 to restore the screen.

Front Panel Key	Laptop or PC Key	Screen Selected
WINDOW UP & DOWN	F1	Returns to first screen, then press two keys for direct access to any screen as listed on the next screen
WINDOW DOWN	F2	Select next screen
WINDOW UP	F3	Select previous screen
VALUE+	F4	Increase program value
VALUE-	F5	Decrease program value
FIELD RIGHT	SPACE	Select next field in a screen
FIELD LEFT	BACKSPACE	Select previous field in a screen
	F6	Activate full-screen viewing (PC with PTT only)
	SHIFT F6	

Screen code and description, in sequence of appearance		See page
FM	PRODUCT IDENTIFICATION - Model, type, and version	17
SE	SENSORS - Displays temperature of each standard sensor	17
OS	OPTIONAL SENSORS - Displays other sensors	17
RT	RELAY TEST - On/Off relay status and manual override	17
ST	SENSOR TEST - Simulates sensor temperatures	23
RM	RUN TIME METERS - Total on-time for each heater or stage	
DL	DETAIL LOG - Shows history values for seven days	
TL	TREND LOG - Shows history values for one year	
CK	CLOCK - Display and set time and date	17
TS	TIME SCHEDULE - Seven day, 20 schedule, time clock	19
ER	ERASE/RESET - Selective clear or restart	18
MC	MODEM TEST - Terminate call or test modem or fax	28
PD	PERFORMANCE DATA - Savings Analysis	24
DN	TEXT - Company Name	26
PN	TEXT - Property Name	26
SL	TEXT - Site Location	26
FN	TEXT - Disk File Name	26
MS	TEXT - Modem Setup	26
SH	TEXT - Modem Disconnect	26
AD	TEXT - Pager Dial-Out	26
FD	TEXT - Fax Dial-Out	27
PW	TEXT - Security Password	18
PM	TEXT - Front Panel Menu	18
RL	TEXT - Relay Logic (1-12)	23
T1	SELECT - Supply Sensor Offset	25
T8	Not used for this model	
C0	SELECT - Maximum Supply Temperature	19
C1	SELECT - Minimum Supply Temperature	19
C2	SELECT - Outside Temperature for Maximum Supply	19
C3	SELECT - Outside Temperature for Minimum Supply	19
C4	SELECT - Night Setback at Maximum Supply	19
C5	SELECT - Night Setback at Minimum Supply	19
C6	SELECT - Morning Boost at Maximum Supply	20
C7	SELECT - Morning Boost at Minimum Supply	20

Screen codes in **Boldface** are described in detail on the pages listed.

Screen Code and Description - continued		See page
HL	SELECT - Supply High Limit	20
LL	SELECT - Supply Low Limit	20
DW	SELECT - Demand window in minutes	20
DM	SELECT - Demand % for maximum temperature	20
DA	SELECT - Demand % for ASL strategy	20
R0	SELECT - # of Room Sensors Installed	21
R1	SELECT - Desired Daytime Room Temperature	21
R2	SELECT - Desired Nighttime Room Temperature	21
E0	SELECT - Recovery sensor installed	
E1	SELECT - Minimum recovery time	
E2	SELECT - Recovery sensor response	
B0	SELECT - # Branch sensors installed	22
S0	SELECT - Days to Acclimate Residents	19
S1	SELECT - Day of Month for Savings Test	24
S2	SELECT - Old Maximum Supply Temperature	24
HS	SELECT - # of water heaters	22
SP	SELECT - # stages per heater	22
SQ	SELECT - Alternating Relay Sequencing	22
US	SELECT - Use 24Volt on/off sensing	22
DD	SELECT - Deadband (also known as hysteresis)	23
D1	SELECT - Temperature Delay Between Stages	23
LK	SELECT - +- Keys Locked	18
CU	SELECT - Celsius Units	17
LG	SELECT - Access Data Logger #	
XX	SELECT - Fax Graph Max Temp	27
XN	SELECT - Fax Graph Min Temp	27
XM	SELECT - Fax on Day Of Month	27
XW	SELECT - Fax on Day of Week	27
XH	SELECT - Fax on Hour of Day	27
MO	SELECT - Operating Mode	17
BA	SELECT - Communication BAUD Rate	26
NI	SELECT - Network address number	

FIRST SCREEN AT POWER-UP

FM PRODUCT IDENTIFICATION. This screen displays the model number, type of control, copyright notice, and software version number. Press F2 to select the next screen in order, or press two keys for direct access to any one of the following screens.

MANUAL OVERRIDE

MO SELECT (MODE) - Operating Mode selects one of three states of operation. In Run mode all control functions are operational. In Bypass mode, control is returned to the mechanical controls if provided. In Off mode all systems are shut off and remain off indefinitely. In all three modes the RayTemp data logger and modem/fax functions continue to operate.

VIEW SENSORS AND RELAYS

SE SENSORS - Displays the setpoint and current temperature reading from each primary temperature sensor.

OS OPTIONAL SENSORS - Displays current temperature reading from each optional temperature sensor.

RT RELAY TEST - Displays on/off status of each relay output. Press SPACE or BKSP to a select relay (flashes). Then press F4 to test on, F5 to test off. To return control to the RayTemp, press SPACE or BKSP until no locations flash. The RayTemp will automatically retake control if no manual testing takes place for five minutes.

TIME AND DATE

CK CLOCK - Displays present time and date. To set, press SPACE, F4 and F5.

CELSIUS / FAHRENHEIT SCALE

CU SELECT - For Celsius units, select Yes and all process and program values will be displayed in the Celsius temperature scale. (The default setting of No selects the Fahrenheit scale.)

ERASE MEMORY / RESET PROGRAM

ER ERASE/RESET - Press F4 or F5 to select which item will be reset or cleared, then press CTRL+E to confirm each action.

Set **BAUD Rate** will reconfigure the serial port according to the BA screen. If the speed is different, then reset the BAUD rate on your LapTop (garbage characters will appear).

Zero Run Meters set all run-time meters to zero.

Erase History sets all 7-day and 365-day history to -30.

Reset Program sets all program values to factory default values.

Erase All does all the above (requires 30 seconds).

SECURITY PASSWORD

PW TEXT - Security Password This screen is used to prevent unauthorized access to the RayTemp, either by modem or direct connection. To use this feature, select a password up to 40 characters and enter it on this screen. Then, all future communication with the control will be blocked until this password is entered. A screen will appear asking for the password. Make a note of your password, since you will not be able to access the control without it! By default, no password is required. To disable password protection erase all text in this field.

FRONT PANEL MENU / LOCK

PM TEXT - Front Panel Menu This option provides for limited access by the building caretaker to a fixed set of screens from the front panel. By default, 13 of the most commonly used screens are accessible from the front panel. They are identified in this screen by their two character access code. This line of text can be modified to select a custom set of screens, in any order, up to 13 screens. If the first character on this line is a space (' ') then this menu system will be disabled and all screens will be accessible from the front panel. To gain access to all of the screens using only the front panel, press both VALUE keys while in the PRODUCT IDENTIFICATION screen. This enters a first character space as described above.

LK SELECT - +- Keys Locked When Activated This option prevents changing of programmed values from the RayTemp front panel + and - keys.

WARNING: This option cannot be deactivated from the control itself. Deactivating this screen requires either (1) a connection to a PC running the PTT software, or (2) returning the control to the manufacturer to have them reset this option.

TIME SCHEDULE

TS TIME SCHEDULE This is a seven-day time clock. Each line is a program for starting a new period (such as Night) on a day (such as M-F) and at a time (such as 6:00 am). Up to 20 lines can be displayed or programmed using the SPACE, F4 and F5 keys. Periods end automatically when a new one starts. The day codes are M-F (Monday thru Friday), S-S (Saturday and Sunday), F-S (Friday thru Sunday), and --- (no days). The recommended setting for initial programming is --- (no days) on all settings. Changes can be made to accommodate individual schedules.

SUPPLY TEMPERATURE

The RayTemp control strategy closely matches water temperature to demand as hot water use varies throughout the day. The setpoint is adjusted based on a demand profile which is recorded for the last seven days. The RayTemp scans this profile and adjusts the setpoint in anticipation of demand. This strategy is complemented with a seven-day time clock which can provide fixed temperatures during certain hours for special requirements, such as laundry.

C0 SELECT - Maximum Regular Temperature During Regular periods the desired temperature will be set between (screen) C0 and C1 according to demand. The time clock schedule determines when Regular takes effect. **Default Temp 140°F.**

C1 SELECT - Minimum Regular Temperature The supply temperature will not be set below this value during Regular periods. **Default Temp 130°F.**

C2 SELECT - Maximum Peak Temperature C2 and C3 become the new maximum and minimum temperatures when the time clock schedule is in Peak mode. **Default Temp 140°F.**

C3 SELECT - Minimum Peak Temperature During peak periods the supply temperature will not be set below this value. **Default Temp 130°F.**

C4 SELECT - Maximum Laundry Temperature C4 and C5 will be the maximum and minimum temperatures in effect if Laundry is activated by the seven-day time clock. For laundry needs C4 and C5 will usually be set to the same value. **Default Temp 140°F.**

C5 SELECT - Minimum Laundry Temperature See C4 above. **Default Temp 140°F.**

C6 SELECT - Maximum Extra Temperature C6 and C7 are an extra set of temperatures which can be scheduled for any purpose. They will become the maximum and minimum supply temperature if the Extra schedule is activated by the time clock. **Default Temp 140°F.**

C7 SELECT - Minimum Extra Temperature See C6 above. **Default Temp 130°F.**

HL SELECT - Supply High Limit If the recovery temperature or the return temperature is very low, the RayTemp may need to take the supply temperature above the programmed maximum. Regardless of any conditions, the RayTemp will not take the supply or any branch temperature above this high limit value. If the supply temperature exceeds this value by 10°F then alarm dial-out will be activated. **Default Temp 140°F.**

LL SELECT - Supply Low Limit The RayTemp will not schedule the supply temperature lower than this value (or programmed minimum). If the supply temperature drops 10°F below this value then alarm dial-out will be activated. **Default Temp 120°F.**

DW SELECT - Demand Windows in Minutes This value sets the time period of demand history to be used in calculating desired temperature. The default value should yield a smooth profile. Decreasing this value will cause faster response to changing demand at the risk of instability. Increasing this value will produce a very smooth desired temperature profile, however the temperature may not rise quickly enough during peak demand periods. The range is from 10 to 90 minutes. **Default Value 40.**

DM SELECT - Demand % for Maximum Temperature This feature provides a means of increasing temperature in oversized systems which show very little demand. Example: Set to 50%. When demands of 50% or more are encountered, the desired temperature will be at programmed maximum. Below 50% the desired temperature will be proportional between maximum and minimum programmed values. The range is from 10 to 100 percent. **Default Value 100.**

DA SELECT - Demand % for ASL Strategy This feature automatically adapts to manual changes in the optional, secondary aquastat setting which may occur after installation. This ensures continued savings even if the aquastat is lowered. (ASL is an acronym for Aquastat Set too Low). The strategy works by lowering the setpoint temperature until the RayTemp has regained control. For each 24-hour period that demand exceeds this DA percent, the setpoint is lowered by 5°F. Then for each 24-hour period that heater demand is less than one half of DA, the setpoint is increased by 1°F until the original value is restored. The default value is 70%. The PERFORMANCE DATA screen titled Temp Reduced by ASL Strategy will show a value other than zero if this strategy is in effect. **Default Value 70.**

RETURN TEMPERATURE

The return sensor is used to compensate for seasonal changes in loop heat loss. The strategy may raise the supply/branch temperature in cold weather to ensure that the last rooms on the loop have hot enough water even during low demand periods.

R0 SELECT - Return Sensor Installed Select YES if this sensor is connected, otherwise select NO. Default is YES.

R1 SELECT - Minimum Return Temperature If the return temperature drops below this value then the return sensor strategy will be activated. Above this value, the strategy will have no effect on desired temperature. Default Temp 108°F.

R2 SELECT - Return Sensor Response This is a multiplier which increases the desired temperature as the return temperature drops. Example: desired = 130, return = 100, R1 (above) = 102, R2 = 5. The desired temperature will be increased to $140 = 130 + (102-100) \times 5$. Default Value is 1.

BRANCH TEMPERATURE - NOT USED

BO SELECT - # of Branch Sensors Installed Not used.

RELAY SEQUENCING

HS SELECT - # of Heaters Enter 1 thru 4 for the number of heaters connected to relay outputs 1 thru 4. This allows the RayTemp to correctly sequence heaters and record demand.

SP - SELECT - Stages Per Heater Enter the number of stages in each heater, from 1 to 4.

SQ - SELECT Firing Options

Four options for stage sequencing are available. Select number 1, 2, 3, or 4 as follows:

- #1 No Lead/Lag: Stage 1 of heater #1 always fires first. The remaining stages and heaters will fire in order as demand increases.
- #2 24-Hour Rotation: At midnight each day, the firing order is rotated to the next heater. This distributes the work load equally among all heaters.
- #3 Lead/Lag & Rotate: With this option, heater #1 always fires first, then the remaining heaters fire in rotation. Since some designs require heater #1 to fire first; this option meets this requirement while still providing limited rotation.

flue

US SELECT - Use 24volt on/off sensing. Do not use.

DD SELECT - Differential Increasing DD lengthens the heater burn cycle; decreasing DD improves temperature stability. For instance: desired=140, deadband=1, heater turns off at 141 and on at 139. This deadband applies equally to all stages.

D1 SELECT - Temperature Delay Between Stages (In addition to differential setting) This value causes successive output stages to come on according to the deviation to target temperature. D1 activates additional heaters or stages as demand increases. For example with a set-point of 140°F and a temperature delay of 1°F, stage 1 will fire at 140, stage 2 at 138, stage 3 at 136, etc., assuming 2°F deadband.

RL TEXT - Relay Logic (1-12) The default value is ++++++. NOTICE: If you select minus (-) and the RayTemp loses power or fails, then the heater or pump will remain off!!! Edit text with SPACE, BACKSP, F4, and F5 to return to a plus setting.

SENSOR OVERRIDE TEST

ST SENSOR TEST This feature allows you to simulate any sensor temperature and observe the affect on desired temperature and relay sequencing. Press SPACE or BKSP to select a sensor, then override the actual sensor temperature by pressing F4 or F5. Each key stroke changes the temperature by one degree F. Press Shift+F4 or Shift+F5 to adjust the temperature by one-tenth of a degree (works with PTT). You can change any or all sensors values and then look at other screens. While in this mode all temperature values will be frozen at the values you select. To restore the actual sensor values, press SPACE or BKSP until Inactive ###.# appears. The RayTemp will automatically restore actual sensor values 30 minutes after exiting this screen.

SAVINGS TEST SETUP

S1 SELECT - Day of Month for Savings Test Selecting a value other than 0 (default) activates the flip-flop savings test. This test will cause a simulation of conditions before the RayTemp was installed - for 24 hours on the day specified every month. The test will run only on the day of month selected AND on multiples of that day. Examples: Values 16 thru 28 will run test for that day only. Value 14 will run test on day 14 and 28. Value 5 will run test on day 5, 10, 15, 20, 25, and 30. One day of testing may not yield accurate results, while four or more days of testing will significantly cut into savings. The recommended value is **14** (2 test days).

S2 SELECT - Old (Maximum) Supply Temperature Enter the supply temperature prior to installing the RayTemp if you wish to use the Acclimate feature or Savings Test feature (above). If the preexisting control operated at a fixed temperature enter that value here and also in the next screen.

SAVINGS TEST RESULTS

PD PERFORMANCE DATA From this screen press F4 or F5 to view savings analysis statistics as described below:

Average Energy Savings % Displays the average energy savings in percent during the last 365 days. This can be used to determine actual dollars savings and payback period. This feature will not operate unless a day of month for savings test is selected. A flip-flop test then is activated which alternates between RayTemp mode and baseline mode (which has higher energy consumption).

Baseline Heater Run Time % Displays average heater demand during Baseline mode for the last 365 days (simulating a fixed setpoint control). This is diagnostic information used in calculating savings.

RayTemp Heater Run Time % Displays average heater demand for all heating days except baseline days during the last 365 days. This is diagnostic information used in calculating savings.

Days in Baseline Mode Shows the number of days during the last year that RayTemp was in baseline mode - simulating the preexisting fixed setpoint control.

Days in RayTemp Mode Shows the number of days during the last 365 days when there was demand for heat and baseline mode was not in effect.

Total days in service displays the total operating days in modes RUN, BYPASS, and OFF. When 24 VAC power is absent this value will not increase however the clock will still operate.

Number of power interruptions value is incremented each time 24 VAC power is removed or interrupted.

ASL strategy temp reduced a value other than zero indicates that the RayTemp has reduced its set-point temperature by this amount. This was done to regain control because the existing aquastat setting was lowered.

SENSOR CALIBRATION

The following screens allow you to introduce a fixed positive or negative offset to any temperature input. You will not normally need to make any adjustments here since RayTemp sensors and electronics are very accurate. The default values in these screens compensate for a small self-heating affect on the thermistor sensor. For small-mass base thermistors, the offset is -2.5°F. For thermistors mounted in housings or attached to a pipe with thermal paste the offset is -1.5°F.

You can check measurement accuracy of RayTemp using fixed resistors and the resistance/temperature chart published by Independent Energy. Before doing this first set each offset below to zero.

T1 SELECT - Supply Offset for sensors 1 thru 7

T8 SELECT - Supply Offset for sensors 8 thru 15. **Not used for this model**

LOCATION TEXT

DN TEXT - Company Name Accepts entry of company name into RayTemp memory. This information will appear in installation reports. Edit with SPACE, BACKSP, F4, and F5.

PN TEXT - Property Name Accepts entry of site name into RayTemp memory. This information will appear in installation reports. Edit with SPACE, BACKSP, F4, and F5.

SL TEXT - Site Location Accepts entry of city and state names into RayTemp memory. This information will appear in installation reports. Edit text with SPACE, BACKSP, F4, and F5.

FN TEXT - Disk File Name Accepts entry of a DOS file name into RayTemp memory. The installation report and graphs will be saved in a file under this name (seven characters maximum). Edit text with SPACE, BACKSP, F4, and F5. **Only needed when logging data to a connected LapTop.**

DATA MODEM SETUP

BA SELECT - Communication Baud Rate For direct connect, use 9600 Baud. For modem use, set at required 9600. Speed is activated only during power-on reset or from ER ERASE/RESET screen.

MS TEXT - Modem Setup Accepts entry of AT command string into RayTemp memory. If a modem is installed, the RayTemp will transmit this command string to configure your modem. Use the Hayes-compatible modem manual for information about the AT commands. This text will also appear on installation reports. Edit text with SPACE, BACKSP, F4, and F5. Once set, write down at command string.

SH TEXT - Modem Disconnect Accepts entry of AT commands into RayTemp memory. If a modem is installed the RayTemp will transmit this command to the modem to terminate the phone connection and prevent the modem from answering another call.

AD TEXT - Pager Dial-Out Accepts entry of AT commands into RayTemp memory. If a modem is installed the RayTemp will transmit this command to the modem if an alarm condition exists. For example, commands can be selected to dial a pager and display a code to identify the calling RayTemp unit. Consult your Hayes-compatible modem manual for more information about AT commands. This text will appear on installation reports. Edit text with SPACE, BACKSP, F4, and F5.

FAX MODEM SETUP AND TEST

FD TEXT - Fax Dial-Out Use this screen to enter the phone number of the fax machine which is to receive fax alarm messages, installation reports, and/or graphics. Example "ATDT5551212". Edit text with SPACE, BACKSP, F4, and F5.

XX VALUE - Fax Graph Max Temp This value sets the highest value of the Y-axis temperature scale for all faxed graphs. This item is unrelated to PC graphics. Autoscaling is not supported.

XN VALUE - Fax Graph Min Temp This value sets the lowest value of the Y-axis temperature scale for all faxed graphs. This item is unrelated to PC graphics. Autoscaling is not supported.

XM VALUE - Fax on Day of Month A complete installation report with graphics of logged data can be automatically faxed, once a month, to any group III fax machine. This value sets the day of the month to transmit this data. The report consists of seven pages. The first two pages give all program values and performance data, such as percent savings. The next three and one-half pages are detailed graphs for the last seven days. The last one and one-half pages are trend graphs for the last 12 months. The default day of zero disables this function.

XW VALUE - Fax on Day of Week Detailed graphs of logged data for the last seven days can be automatically faxed, once a week, to any Group III fax machine. This value sets the day of the week to transmit this data.

Value	Transmit	Day Graphs
0	None	None
1	Monday	Last 7 days on 3 1/2 pages
2	Tuesday	Last 7 days on 3 1/2 pages
3	Wednesday	Last 7 days on 3 1/2 pages
4	Thursday	Last 7 days on 3 1/2 pages
5	Friday	Last 7 days on 3 1/2 pages
6	Saturday	Last 7 days on 3 1/2 pages
7	Sunday	Last 7 days on 3 1/2 pages
8	Every Day	Yesterday full size on 1 page

XH VALUE - Fax on Hour of Day This option sets the time of day to transmit fax reports. It works in conjunction with XW and XM, above. The RayTemp will attempt to fax the specified data on the specified day (above) and at this specified time. Military time is used with values of 0 to 23, 12 is noon. If the first attempt is not successful then the RayTemp will make two more attempts at 10 minute intervals. Where multiple RayTemps are calling into one fax machine it's very important to set each control to a different day and/or time, otherwise some controls may always get a busy line.

MC MODEM TEST This screen provides for modem testing and manual fax transmission of reports and graphics. The following table describes the options in this window. These options are selected using the FIELD keys and activated by pressing the PLUS key. The "Status:" line in this window reports progress of the action as shown in the second table below.

Option	Transmit	Function Pages
Setup	"Modem Setup" command to modem	N/A
Disconnect	"Modem Disconnect" command to modem	N/A
Pager Alarm	"Pager Dial-Out" command to modem	N/A
Fax Alarm	Warning message, identifies location	1
Fax	Report Installation report	2
Fax Year	Trend graphs for last 12 months	3
Fax Month	Trend graph for the 4 month period	1
Fax Week	Detailed graphs for the last 7 days	4
Fax Today	Detailed graph for one day, today	1
Fax Yesterday	Detailed graph for one day, yesterday	1
Fax All	Report and all graphs	7

Status	Description
(blank)	No Activity
Sending	Transmission in process. This message may remain for up to 12 minutes depending on the action selected
OK	Data modem or fax modem has successfully completed the operation. Failed data modem or fax modem did not reply or was unable to complete the action requested
Failed	Data modem or fax modem did not reply or was unable to complete the action required

Note: The "Pager Alarm" action will always reply "Failed" because the modem does not connect with another modem. In this screen, no actions will retry in the event of transmission failure (press plus (+) again). However when actual alarm conditions occur or when reports are scheduled for automatic transmission the RayTemp will retry. Up to three attempts will be made, per day, at 10-minute intervals.

WARRANTY

The Raypak RayTemp Control is warranted to be free from defects in material and workmanship for a period of one year from the date of installation or fourteen months from date of shipment, whichever occurs first.

THE FORGOING WARRANTY IS IN LIEU OF AND EXCLUDES ALL OTHER WARRANTIES NOT EXPRESSLY SET FORTH HEREIN, WHETHER EXPRESSED OR IMPLIED BY OPERATION OR LAW OR OTHERWISE, INCLUDING BUT NOT LIMITED TO ANY IMPLIED WARRANTIES OF MERCHANTABILITY OF FITNESS.

At its option, Raypak will repair or replace any RayTemp Control which fails to conform to this warranty. Repair or replacement shall be the sole remedy of the buyer under this warranty, and Raypak shall not be liable for any installation, removal or reinstallation costs, or for any damage and/or injury to building, contents, products or persons by reason of the installation of the RayTemp Control, or for incidental or consequential losses, damages or expenses, including loss or profits, directly or indirectly arising from this sale, handling or use of the goods, or from any other cause relating thereto, whether such claims are for breach of warranty or negligence.

Any claim by buyer with reference to the Raypak RayTemp Control sold hereunder for any cause shall be deemed waived by buyer unless submitted to Raypak in writing within thirty (30) days from date buyer discovered, or should have discovered, any claimed breach. To obtain service under this warranty, call or write:

RAYPAK, INC.
2151 Eastman Avenue
Oxnard, CA 93030
805-278-5300

SERVICE/RETURN AUTHORIZATION PROCEDURE

Raypak will not accept a returned unit unless the buyer has received prior authorization to return the unit. If a problem is suspected with the RayTemp control while under warranty, the owner or operator should first call the installing dealer. The dealer should contact Raypak at the above phone number for return authorization. Required information: name of site, location, serial number, reason for return. An authorization number will be issued. Repaired or replacement equipment will be returned to you prepaid.

Warranty Card

Please return this card within 30 days of installation to initiate your warranty and enable us to better serve you

Control Model: _____ Date Purchased: _____
Control Serial Number: _____ Date Installed: _____
Water Heater Model Number: _____ Water Heater Serial Number: _____
Company Name: _____ Contact Name: _____
Company Address: _____ City: _____ State: _____ Zip Code: _____
Installation Location: _____
Installation Address: _____ City: _____ State: _____ Zip Code: _____
Type of Property: Apt/Condo _____ Hotel/Motel _____ Other _____
RayTemp Dealer: _____ Address: _____
City: _____ State: _____ Zip Code: _____



www.raypak.com