



# 6 Series Controlled Temperature Heated Holding Cabinets

---

## USER MANUAL

Metro Heated Cabinets are for  
Hot Food Holding applications only



InterMetro Industries Corporation  
Wilkes-Barre, PA 18705  
570-825-2741 www.metro.com





## 6 SERIES HEATED CABINET BASIC OPERATING GUIDELINES

1. With the POWER switch OFF, plug the supply cord into a grounded 20 amp 120VAC receptacle. (refer to the cabinet data plate for ampere rating).
2. Ensure that the cabinet's floor duct and water pan are installed. (refer to the cabinet operating instructions). This helps to distribute the heat evenly throughout the cabinet.
3. If extra humidity is desired, fill the water pan in the floor duct of the cabinet with clean warm water. The capacity of the pan is about one quart (one liter).
4. Set the power switch to the ON position. The red power light next to the switch will glow when the power is switched ON and will continue to glow until switched OFF.
5. Set the TEMPERATURE control to 6 or 7. This should provide a temperature of 150° to 170°F after allowing the cabinet to preheat for 45 to 60 minutes.
6. The red indicator light between the thermostat and thermometer will turn on and off as the thermostat and heat elements cycle.
7. To change temperature set point, turn the TEMPERATURE control knob. About 30 minutes after the knob is turned, the thermometer should accurately display the change in cabinet temperature.
8. To clean the cabinet, turn the power off, unplug from wall the outlet, allow the cabinet to cool, remove the floor duct and pan, wipe the cabinet with a damp cloth and dry with a towel.
9. Consult the user manual for additional operation and maintenance information.



### CAUTION



- ✓ UNPLUG CABINET FROM WALL, ALLOW CABINET AND WATER TO COOL, BEFORE CLEANING OR SERVICING.
- ✓ SOME SURFACES, WATER, AND ESCAPING VAPOR CAN BE HOT ENOUGH TO BURN. USE CAUTION WHEN OPENING DOORS AND WORKING IN AND AROUND THIS CABINET.
- ✓ DO NOT SPRAY OR POUR WATER INTO THE CONTROLLER ENCLOSURE. TO CLEAN CABINET, WIPE WITH A DAMP CLOTH AND DRY WITH A TOWEL.
- ✓ KEEP THE CABINET CLEAN. ACCUMULATION OF GREASE AND DIRT MAY IGNITE.

# TABLE OF CONTENTS

SECTION	PAGE
I. Basic Operating Guidelines.....	Inside Front Cover
II. Safety Instructions.....	1
III. Identifying Your Cabinet .....	2
IV. Installation & Set-up.....	3
V. Product Features .....	7
VI. Operating Instructions.....	8
VII. Care & Maintenance.....	9
VIII. Basic Troubleshooting .....	10
IX. Service & Replacement Parts.....	11
X. Warranty.....	Inside Back Cover

## SAFETY INFORMATION

**WARNING:** Follow all food safety guidelines. Pre-heat the cabinet to the desired temperature before placing cooked, hot food into the cabinet. This is not a re-thermalizing cabinet. Food must be at the appropriate temperature before being placed into this cabinet. Use a food probe to check internal food temperature — the cabinet temperature is not necessarily the internal food temperature.

**WARNING:** Only factory approved service agents should attempt to service, repair or replace electrical components, wiring or power cord.

**WARNING:** Unplug the cabinet before cleaning or servicing. Do not wash the cabinet with a water jet or high pressure water.

**WARNING:** This cabinet is for hot food holding applications only.

**CAUTION:** Do not spray or pour water into the top of the cabinet (control enclosure). To clean the cabinet, wipe with a damp cloth and dry with a towel. Use only cleaning agents approved for stainless steel or aluminum (depending on your cabinet construction).

**CAUTION:** Water dripping onto the floor from open doors can be a slip hazard.

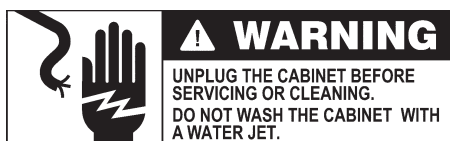

# IDENTIFYING YOUR CABINET

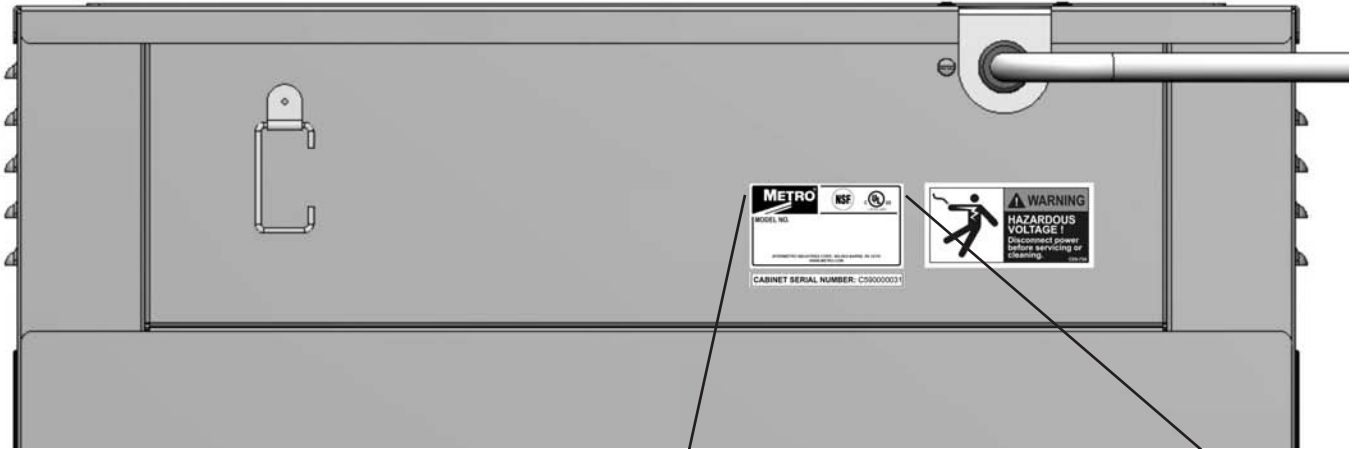

For future reference, note the serial and model number, found on the data plate of the cabinet, here.

Serial number \_\_\_\_\_

Model number \_\_\_\_\_

Date the cabinet was put into service \_\_\_\_\_

Fill out and return the warranty card located at the back of this manual.

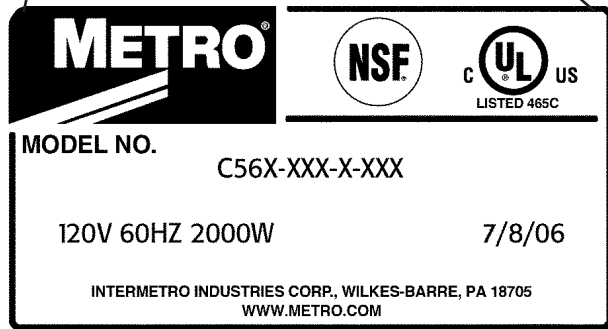

**CABINET SERIAL NUMBER: C560000050**

## PART NUMBERING

**C5 6 9 - S FS - L P FS A**

**CABINET NAME** \_\_\_\_\_

**CABINET TYPE** \_\_\_\_\_

6 = 6 SERIES  
(HEATED)

**CABINET SIZE (HEIGHT)** \_\_\_\_\_

9 = FULL

7 = 3/4

5 = 1/2

3 = UNDER COUNTER

**MATERIAL** \_\_\_\_\_

S = STAINLESS

N = ALUMINUM

A = ACCESSORIES (IF APPLICABLE)

**REAR DOOR(S)  
(PASS-THRU)**

BLANK = NON-PASS THRU

FS = FULL SOLID

DS = DUTCH SOLID

FC = FULL CLEAR

DC = DUTCH CLEAR

**CABINET CONSTRUCTION**

BLANK = NON-PASS THRU

P = PASS-THRU, DOORS  
(FRONT & REAR)

**SLIDES**

L = LIP LOAD (FIXED)

U = UNIVERSAL (ADJUSTABLE)

**FRONT DOOR(S)**

FS = FULL SOLID

DS = DUTCH SOLID

FC = FULL CLEAR

DC = DUTCH CLEAR

# INSTALLATION AND SET-UP

1. Check for Shipping Damage: Check the packaging and cabinet for shipping damage before and after unloading the unit, and after removing all the packaging.
2. The receiver of this product is responsible for filing freight damage claims. This equipment must be opened immediately for inspection. All visible damage must be reported to the freight company within 48 hours and must be noted on freight bill at the time of delivery.
3. Concealed damage is your responsibility — you must advise the carrier of any loss or damage within 15 days after receipt of the cabinet. If there is damage, retain the original packaging for inspectors.
4. After unpacking the cabinet, remove all tape and packing material from the inside as well as outside of the unit.
5. Any protective covers (plastic or paper sheet) on the sheet metal or clear door(s), if applicable, must also be removed before turning the cabinet on.

**WARNING:** Only factory approved service agents should attempt to service, repair or replace electrical components, wiring or the power cord.

6. The power cord can be installed to exit the back of the cabinet for wall outlets or out the top of the cabinet for ceiling power drops. To change the position of the power cord, first make sure the cabinet power switch is off and the power cord is unplugged from any electrical outlet. Remove the (7) screws holding the cabinet top in place. Lift the rear portion of the cabinet top and slide it



Cord out of the top



Cord out of the back

away from under the front control bezel, removing it from the cabinet. Remove the (2) screws on the rear of the cabinet that hold the cord bracket in place. Rotate the power cord bracket 90° to the desired position and reattach it with the (2) screws to the back of the cabinet. Make sure the green ground wire connection and the wire nuts on the black and white wires are not loosened. Do not alter the wiring of the power cord to the cabinet. Replace the cabinet top and the (7) screws holding it in place.

7. Plug the power cord into a grounded outlet with a minimum of 20 amp electrical service. The required electrical service is 120 VAC, 60 cycle, single phase. Make sure all applicable local electrical codes are met.

Wrong  
15 Amp Outlet



Correct  
20 Amp Outlet

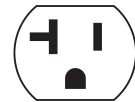

8. Your C5 cabinet is designed to operate next to walls and other kitchen equipment. However, the greater the clearance around the sides and the top of the cabinet, the cooler the electrical components will operate. This may result in a longer life expectancy for the electrical components.

**WARNING:** Do not allow combustible materials to be stored or accumulate on, under or next to the cabinet. Do not block any ventilation louvers or slots.

# INSTALLATION AND SET-UP (continued)

## SLIDE INSTALLATION

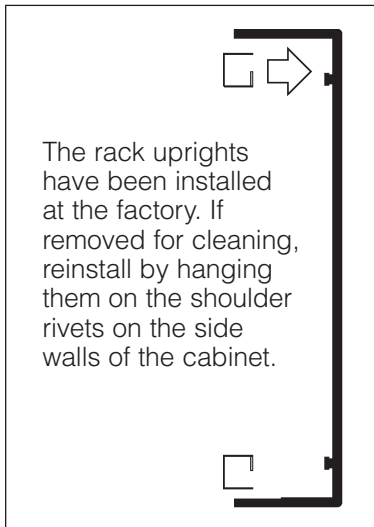

The rack uprights have been installed at the factory. If removed for cleaning, reinstall by hanging them on the shoulder rivets on the side walls of the cabinet.

TOP VIEW

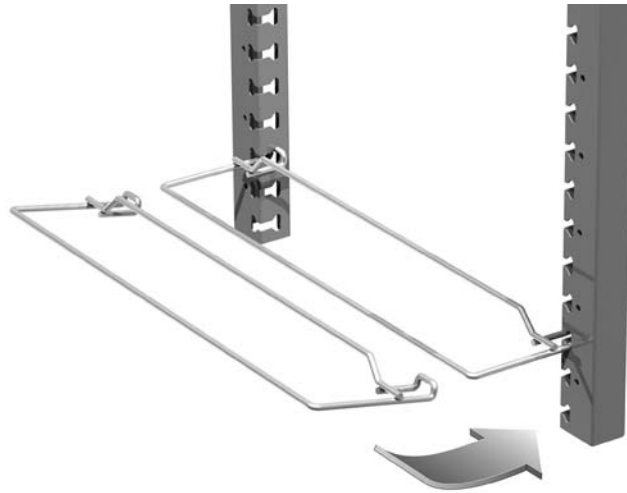

## SLIDE POSITION to MAXIMIZE 3" PAN CAPACITY OF UNIVERSAL SLIDES

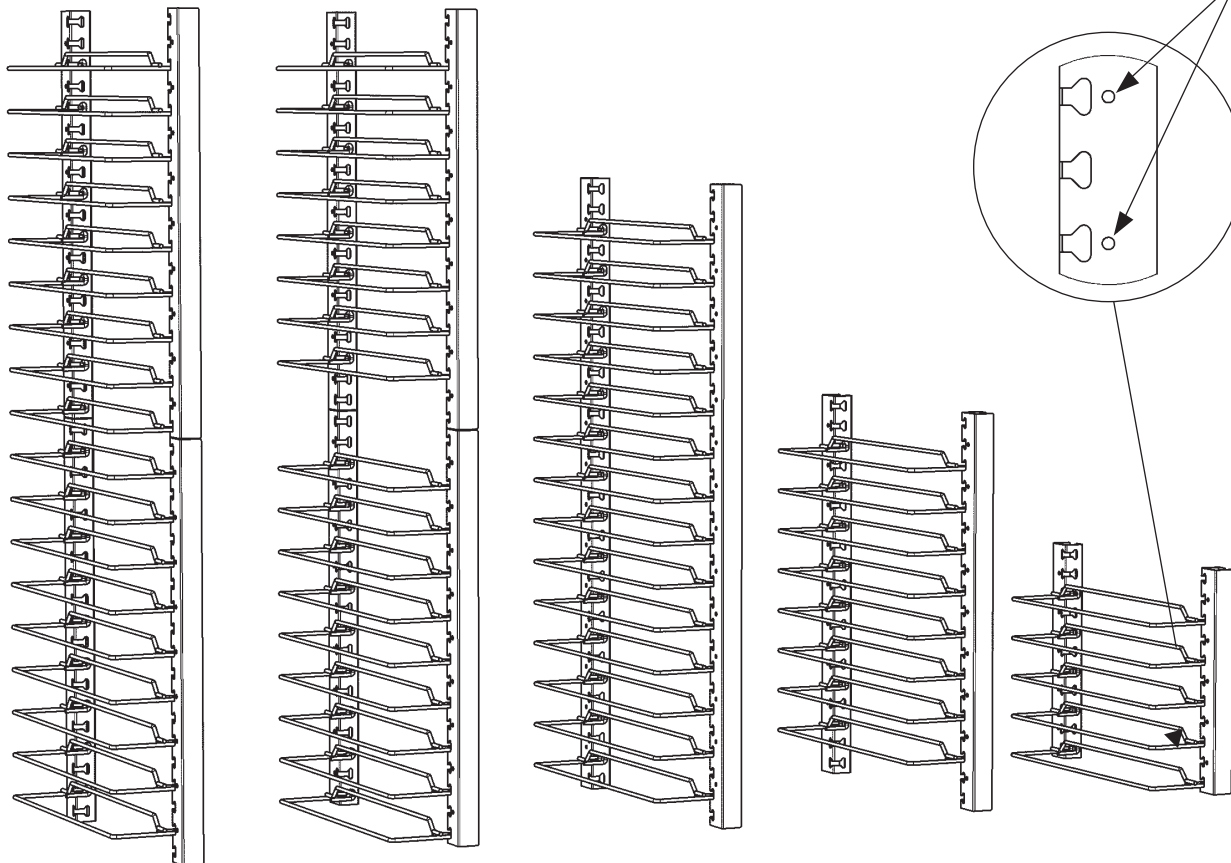

SiteSelect™ features make slide installation easier.

**Full Height Single Door**  
18 Levels  
(Position 2<sup>nd</sup> from Bottom)  
Part No. C5-U-9

**Full Height Dutch Doors**  
17 Levels  
(Position Bottom)  
Part No. C5-U-9

**3/4 Height Cabinet**  
14 Levels  
(Position 2<sup>nd</sup> from Bottom)  
Part No. C5-U-7

**1/2 Height Cabinet**  
8 Levels  
(Position 3<sup>rd</sup> from Bottom)  
Part No. C5-U-5

**Under Counter Cabinet**  
5 Levels  
(Position Bottom)  
Part No. C5-U-3

Slides sold in pairs. For additional pair of wire slides, order C5-USLIDECPR.

# INSTALLATION AND SET-UP (continued)

## CORRECT ORIENTATION OF LIP LOADED SLIDE RACKS

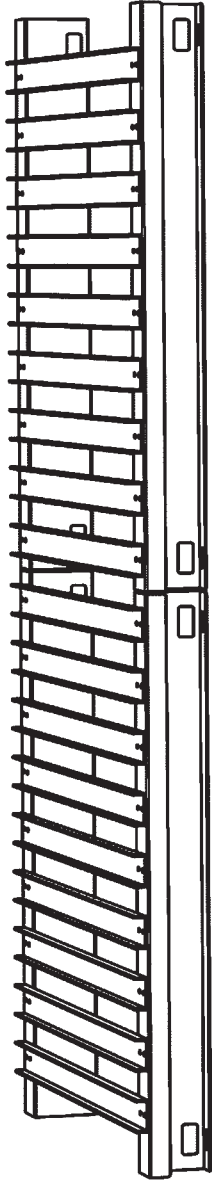

**Full Height  
Single Door**  
2-piece Construction  
Part No. C5-L-9

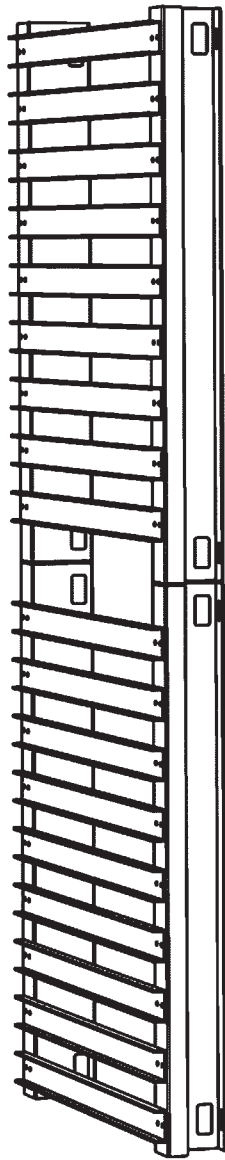

**Full Height  
Dutch Doors**  
2-piece Construction  
Part No. C5-L-9

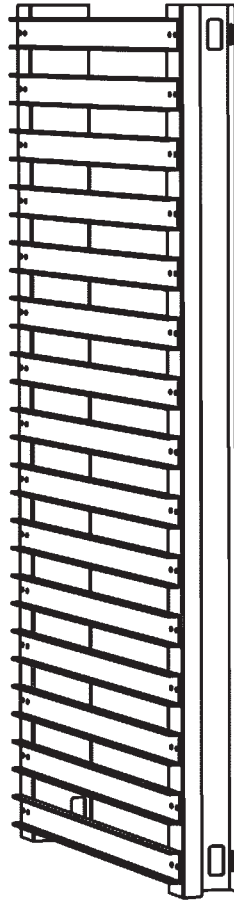

**3/4 Height  
Cabinet**  
1-piece Construction  
Part No. C5-L-7

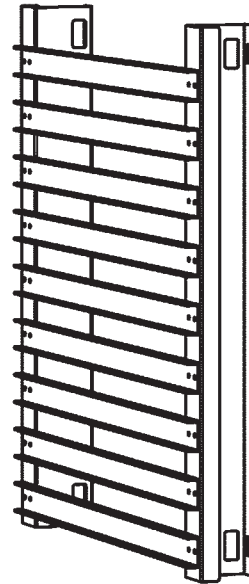

**1/2 Height  
Cabinet**  
1-piece Construction  
Part No. C5-L-5

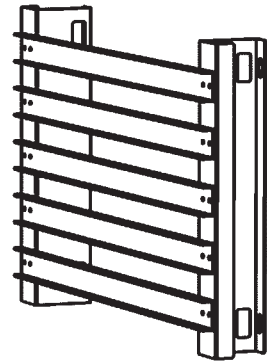

**Under Counter  
Cabinet**  
1-piece Construction  
Part No. C5-L-3

Slides sold in pairs.



# REVERSING THE DOORS

## ⚠️ WARNING • TIP HAZARD

**Tip Hazard:** On Pass-Thru cabinets that include any clear doors, when field reversing, the front and back doors must be hinged from opposite sides of the cabinet. See illustration below.

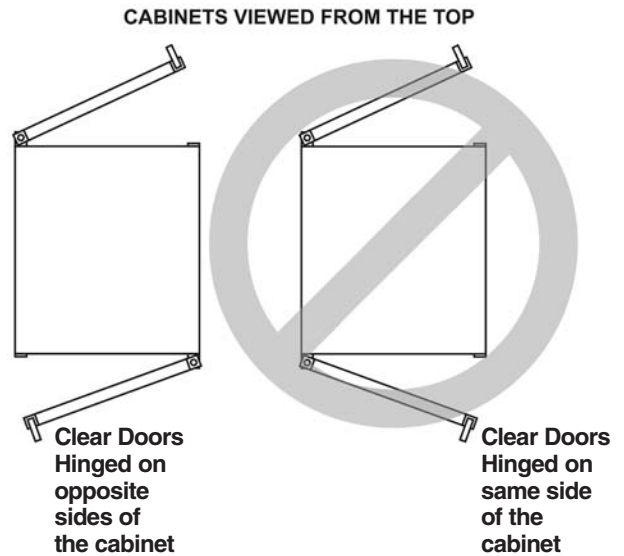
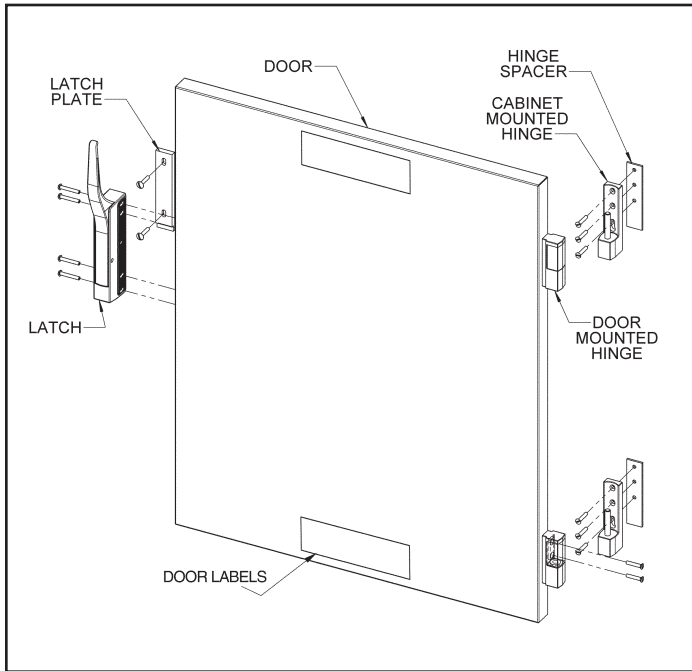

After reversing the door hinging direction, labels are now upside down. You may contact InterMetro for a new set of labels, part number RPC5-DRLBL, at no charge, to be placed in the proper orientation.

C5 doors are normally hinged on the right hand side at the factory. If the cabinet has been in operation, allow the door to cool before reversing the door hinging direction. Note: When finished, all holes must have screws in them and there will be no exposed holes left in the cabinet.

1. If the cabinet has Dutch Doors, note which is the top and which is the bottom door. Open the door, lift it off the cabinet hinges and set it aside noting which is the top and bottom of the door.
2. On the cabinet, remove the latch strike plate and hinges and install them on the other side of the cabinet. On the door, remove the hinge covers to access the mounting screws. Remove the hinges.
3. Rotate the door so the previous bottom is now the top and install the hinges. On Dutch Doors, do not remove the handles, the top door becomes the bottom and the bottom door the top. On single door units, rotate the handles 180° and reinstall.
4. On the cabinet mounted hinges, lift the white bushing and rotate it 180° and push it down to reseal it on the hinge pin.
5. Install the door onto the cabinet hinges and check to make sure the door latches properly and the gaskets are in compression.
6. Fill hinge holes with loose screws.



# PRODUCT FEATURES

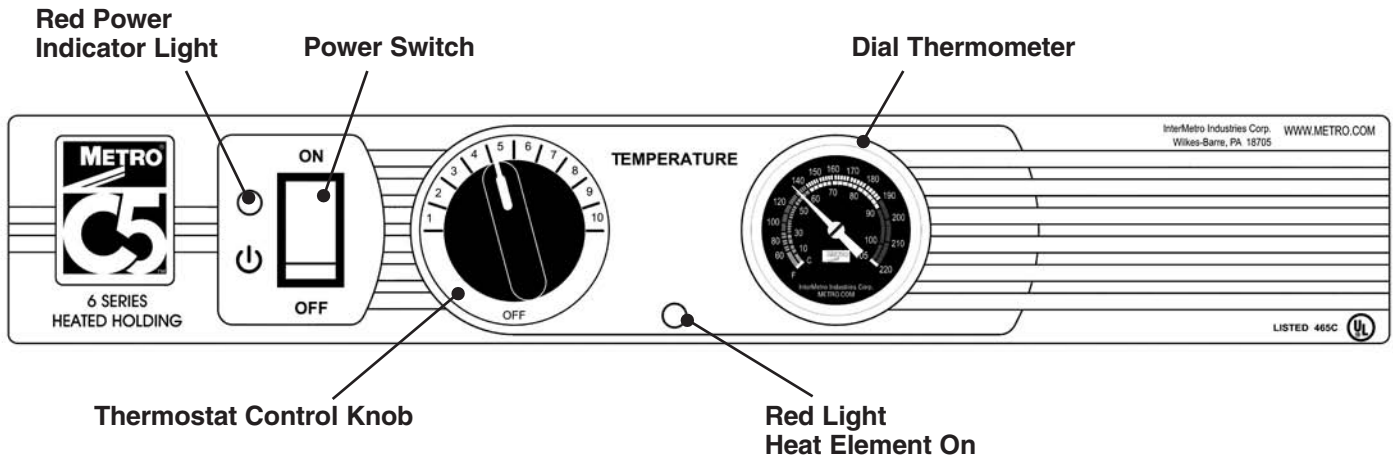
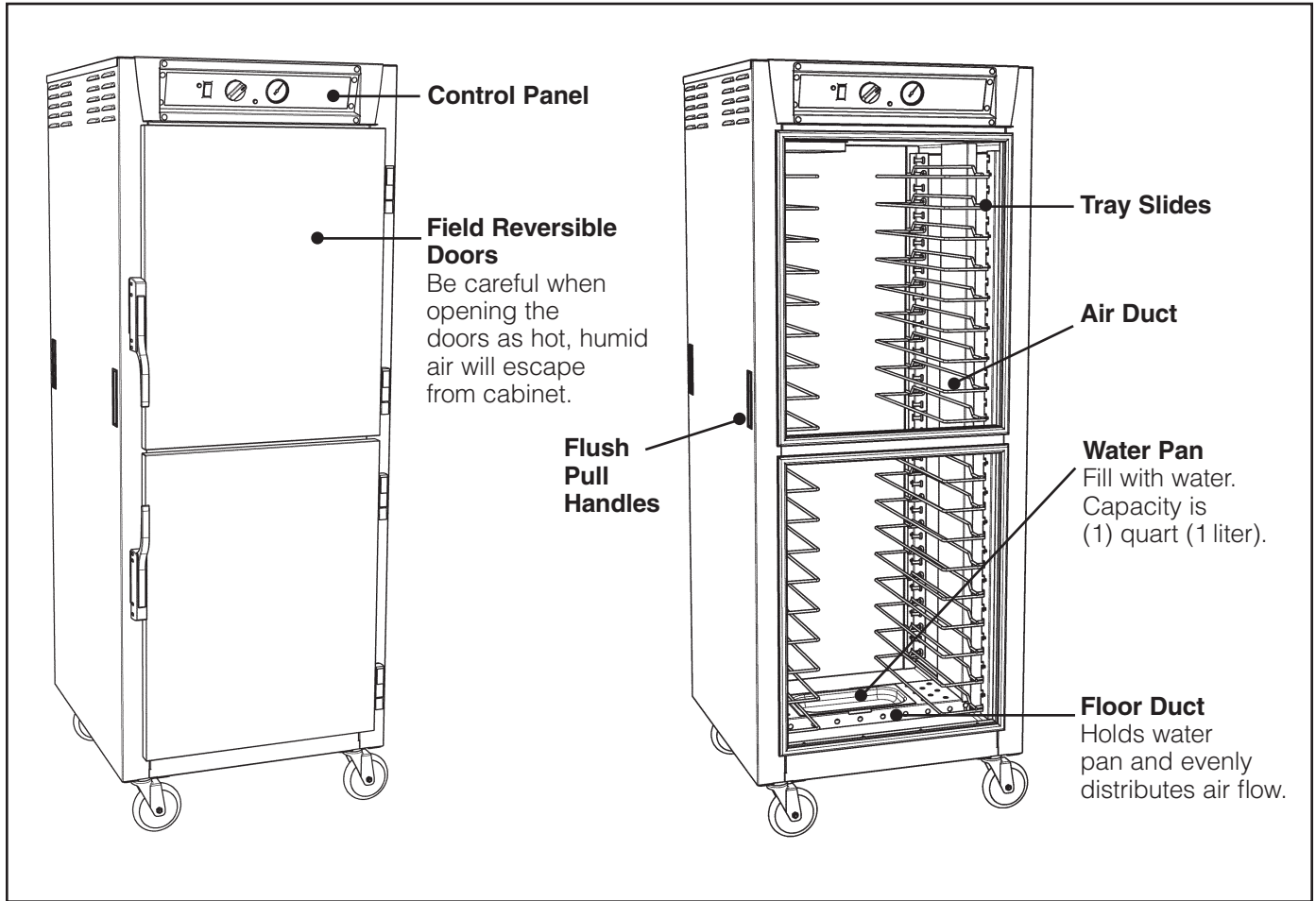

# OPERATING INSTRUCTIONS

## Power-Up & Pre-Heat

- A red indicator next to the on/off switch indicates when the power switch is on and the cabinet has power. It will stay lit until the cabinet is turned off. Turn the cabinet on and adjust the thermostat to the desired setting. The thermometer indicates the internal cabinet temperature. A second red indicator light is located between the thermostat and the thermometer and indicates when the thermostat cycles on to energize the air element (to increase the cabinet temperature). When this light is not illuminated, it means the cabinet has reached the preset temperature level. It is normal for the thermostat to cycle on and off as the cabinet is operating.
1. Set the temperature control to a 6 or 7 setting. This should produce a cabinet temperature of 150° F (66° C) to 170° F (77° C) after allowing the cabinet to preheat for 45-60 minutes. Allow the cabinet to pre-heat without food. The time required to reach the desired temperature is dependent on the set point, the size of the cabinet, the door type (solid or clear) and the temperature of the room the cabinet is in. To change the temperature, turn the temperature control knob. About a half hour after adjusting the temperature control knob, the thermometer should indicate the new cabinet temperature.
- At the end of the operating day, it is not necessary to disrupt the temperature setting to turn the cabinet off. By switching the power switch off, the cabinet is no longer operating. When resuming operations, switch the power on and the cabinet will attain the preset temperature level.

**Warning:** Follow all food safety guidelines. Pre-heat the cabinet to the desired temperature before putting cooked, hot food into the cabinet. This is not a re-thermalization cabinet. Food must be at the appropriate temperature before being placed into this cabinet.

2. Your C5 6 Series cabinet is capable of creating some humid air. As you operate the cabinet and open and close the door(s), condensation may form on the inside surfaces of the cabinet. Some dripping of water may occur to the outside of the cabinet particularly at the door seals. Water may also drip off opened doors onto the floor.

**Caution:** Water dripping onto the floor from open doors can be a slip hazard.

**Warning:** Some surfaces, water and escaping vapor can be hot enough to burn. Use caution when opening doors and working in and around this cabinet.

3. The cabinet control will “remember” its setting when the cabinet is turned off. Therefore, when the unit is turned on the setting will be the same as it was during the previous use.



4. A red indicator light next to the temperature control indicates when the temperature heater element is energized. As the control setting is adjusted, it may take a few moments for the status of the indicator light to reflect the new control setting and cabinet condition depending on when in the control cycle the setting is changed.

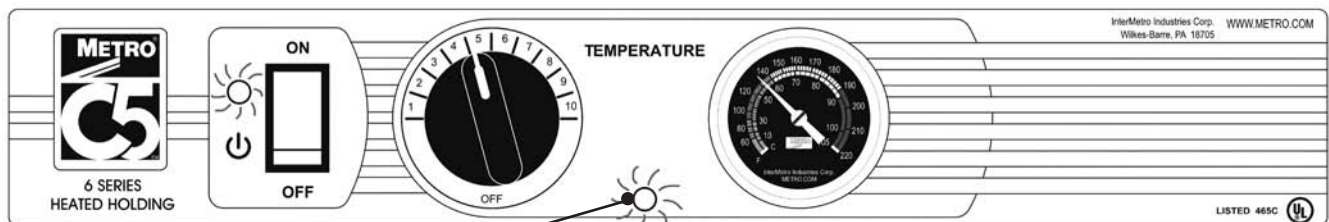

**Red Light**  
Indicates when heat element is on.

- If humidity is required, fill the water pan in the bottom of the cabinet. Potable (suitable for drinking) water should be used.

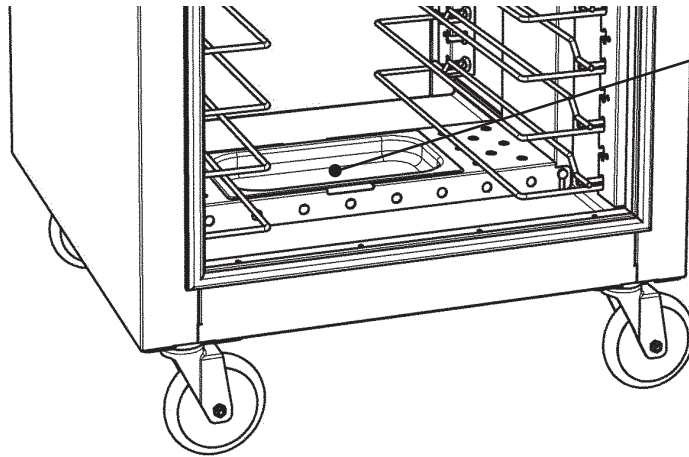

**Water Pan**

Fill with water. Capacity is about 1 quart (1 liter).

	<p><b>⚠ WARNING</b></p> <p>WATER INSIDE THIS CABINET'S PAN IS HOT DURING USE! TURN OFF AND ALLOW TO COOL BEFORE DRAINING THE WATER.</p>
--	---

- To remove the water from the water pan, allow the cabinet and water to cool and remove the water pan.  
**Note:** When turning the cabinet off at the end of the work day, it is recommended to leave the door(s) open to prevent heat and condensation build up within the cabinet.

## CARE & MAINTENANCE

### Cleaning The Cabinet

**Warning:** Unplug the cabinet before cleaning or servicing. Do not wash the cabinet with a water jet or high pressure water.

**Caution:** Do not spray or pour water into the control enclosure. To clean the cabinet, wipe with a damp cloth and dry with a towel. Use only cleaning agents approved for stainless steel or aluminum (depending on your cabinet construction).

**Caution:** Do not use cleaners with chlorides or phosphates as they may cause damage to stainless steel. Do not use strong alkalis on aluminum as they may discolor it.

- Use cleaners in the proper concentrations. Follow the manufacturer's directions for the cleaning product used. After using any cleaning products, thoroughly rinse all surfaces to remove all residue.
- Use a damp cloth or sponge. Mild soap suitable for stainless steel and aluminum is acceptable. Dry with a clean towel. Wipe up spills as soon as possible and regularly clean the cabinet to avoid staining and difficult to clean conditions.

If the control knob needs to be removed for cleaning, use a 1/16" Allen key to loosen the set screw on the control knob. Remove the knob, clean the control face and/or knob and replace the knob and tighten the set screw.

# BASIC TROUBLESHOOTING

**Warning:** Only factory approved service agents should attempt to service, repair or replace electrical components, wiring or power cord.

## 1. Controls do not work (indicator lights):

- a. Check that the cabinet is plugged in.
- b. Check that the outlet has power.
- c. Check that the power switch is in the "On" position.
- d. Check the cabinet wiring from the power cord to the power switch and to the terminal block.

## 2. Temperature too hot:

- a. Temperature set point is too high. Turn control knob down to a lower setting.
- b. If displayed temperature exceeds 220°F (104°C):
  - i. Blower wiring is faulty or disconnected.
  - ii. Blower needs replacing.
  - iii. The thermostat may have failed and the thermal overload device is controlling the temperature. Stop using the cabinet immediately and contact a factory approved service agent.

## 3. Temperature too low:

- a. The cabinet may still be in pre-heat or recovering from a door being opened.
- b. Temperature set point is too low. Turn temperature control knob to a higher setting.
- c. A door is not closed or sealing properly.
- d. Blower is not circulating air:
  - i. Blower wiring is faulty or disconnected.
  - ii. Blower needs replacing.

## 4. No heat generated

- a. If the heat indicator light is on but the cabinet does not draw approximately 16 amps:
  - i. Air heater element may be faulty.
  - ii. The wiring to the air heater element may be faulty or disconnected.
  - iii. The thermostat may be faulty.

## 5. Cabinet trips GFCI (ground fault circuit interrupter):

A GFCI receptacle protects against "ground faults" whenever an electrical product is plugged into the GFCI outlet by constantly monitoring the electricity for any loss of current. If the current flowing out of the receptacle differs by a small amount from that returning, the GFCI quickly switches off power to that circuit. The GFCI interrupts power extremely fast to minimize the possibility of an electric shock.

- a. The heater element may absorb some moisture into its casing and insulation during shipment or during long periods of not being used (such as during the summer in a closed school kitchen). Plug the cabinet (without water in the water pan) into a non-GFCI outlet, set the temperature to "10" and let it run for 30-60 minutes to dry out any moisture the element may have absorbed. (If it trips the standard circuit breaker call factory approved service agent.) After drying the element, plug the cabinet into the GFCI outlet; the cabinet should run without tripping the GFCI.
- b. If the cabinet still trips the GFCI, call a factory approved service agent.

# SERVICE and REPLACEMENT PARTS

## C5 6 SERIES REPLACEMENT PARTS

ITEM #	Replacement Part No.	Description	ITEM #	Replacement Part No.	Description
<b>ELECTRICAL</b>			<b>CABINET BODY (continued)</b>		
1	RPC13-129	THERMOSTAT		RPC5-S3CDRW	STAINLESS STEEL UNDER COUNTER CLEAR DOOR
2	RPC06-476	KNOB		RPC5-N9CDR	ALUMINUM FULL HEIGHT CLEAR DOOR
3	RPC13-127	MASTER SWITCH		RPC5-N7CDR	ALUMINUM <sup>3</sup> / <sub>4</sub> HEIGHT CLEAR DOOR
4	RPC13-218	THERMOMETER		RPC5-N5CDR	ALUMINUM <sup>1</sup> / <sub>2</sub> HEIGHT & BOT D CLEAR DOOR
5	RPC5-REDLT	RED INDICATOR LIGHT, QTY. 1		RPC5-N9CTDDR	ALUMINUM TOP DUTCH CLEAR DOOR
6	RPC11-191	INTAKE COLLAR		RPC5-N3CDR	ALUMINUM UNDER COUNTER CLEAR DOOR
7	RPHM20-2103	BLOWER	17	RPC11-274	DOOR LATCH — 1 PIECE
8	RPC13-093	AIR DUCT ELEMENT		RPC14-118A	FLUSH HANDLE DOOR LATCH — 1 PIECE
9	RPC13-198	THERMAL CUT-OUT		RPC5-LTHTWST	DOOR LATCH WITH TWIST LOCK — 1 PIECE
10	RPC13-099	POWER CORD, STR PLUG	18	RPC14-042	DOOR HINGE — 1 PIECE
	RPC5-RTWSTPLG	POWER CORD WITH TWIST LOCK PLUG	19	B5DNB	5" BRAKE CASTER
	RPQC13-001	POWER CORD WITH RIGHT ANGLE PLUG		B3B	3" BRAKE CASTER
11	RPC13-098	POWER CORD STRAIN RELIEF	20	B5DN	5" SWIVEL CASTER
12	RPC13-096	TERMINAL BLOCK		B3	3" SWIVEL CASTER
13	RPC07-055	GROMMET	21	RPC06-872	POCKET HANDLE
14	RPC56-SCLP	SENSOR CLAMPS & SCREW	22	RPC11-481	WATER PAN
<b>CABINET BODY</b>			*23	C5-L-9	TALL CABINET LIP LOADED SLIDE ASSEMBLY
15	RPC06-836B	FULL HEIGHT DOOR GASKET		C5-L-7	<sup>3</sup> / <sub>4</sub> HEIGHT CABINET LIP LOADED SLIDE ASSEMBLY
	RPC06-836C	<sup>3</sup> / <sub>4</sub> HEIGHT DOOR GASKET		C5-L-5	<sup>1</sup> / <sub>2</sub> HEIGHT CABINET LIP LOADED SLIDE ASSEMBLY
	RPC06-836A	<sup>1</sup> / <sub>2</sub> HEIGHT & DUTCH DOOR GASKET		C5-L-3	UNDER COUNTER CABINET LIP LOADED SLIDE ASSEMBLY
	RPC06-836D	UNDER COUNTER DOOR GASKET	*24	C5-U-9	TALL CABINET UNIVERSAL SLIDE ASSEMBLY (INCLUDES WIRE SLIDES & UPRIGHTS)
16	RPC5-S9DR	STAINLESS STEEL FULL HEIGHT SOLID DOOR		C5-U-7	<sup>3</sup> / <sub>4</sub> HEIGHT CABINET UNIVERSAL SLIDE ASSEMBLY (INCLUDES WIRE SLIDES & UPRIGHTS)
	RPC5-S7DR	STAINLESS STEEL <sup>3</sup> / <sub>4</sub> HEIGHT SOLID DOOR		C5-U-5	<sup>1</sup> / <sub>2</sub> HEIGHT CABINET UNIVERSAL SLIDE ASSEMBLY (INCLUDES WIRE SLIDES & UPRIGHTS)
	RPC5-S5DR	STAINLESS STEEL <sup>1</sup> / <sub>2</sub> HEIGHT & BOT D SOLID DOOR		C5-U-3	UNDER COUNTER CABINET UNIVERSAL SLIDE ASSEMBLY (INCLUDES WIRE SLIDES & UPRIGHTS)
	RPC5-S9TDDR	STAINLESS STEEL TOP DUTCH SOLID DOOR	25	C5-USLIDECPR	UNIVERSAL WIRE SLIDES — 1 PAIR
	RPC5-S3DR	STAINLESS STEEL UNDER COUNTER SOLID DOOR	26	RPC5-SSLEG-1	EQUIPMENT LEG — QTY 1
	RPC5-N9DR	ALUMINUM FULL HEIGHT SOLID DOOR	27	RPC5-DRLBL	DOOR LABELS 1 DOOR (USED WHEN REVERSING DOORS)
	RPC5-N7DR	ALUMINUM <sup>3</sup> / <sub>4</sub> HEIGHT SOLID DOOR			
	RPC5-N5DR	ALUMINUM <sup>1</sup> / <sub>2</sub> HEIGHT & BOT D SOLID DOOR			
	RPC5-N9TDDR	ALUMINUM TOP DUTCH SOLID DOOR			
	RPC5-N3DR	ALUMINUM UNDER COUNTER SOLID DOOR			
	RPC5-S9CDR	STAINLESS STEEL FULL HEIGHT CLEAR DOOR			
	RPC5-S7CDR	STAINLESS STEEL <sup>3</sup> / <sub>4</sub> HEIGHT CLEAR DOOR			
	RPC5-S5CDR	STAINLESS STEEL <sup>1</sup> / <sub>2</sub> HEIGHT & BOTTOM D CLEAR DOOR			
	RPC5-S9CTDDR	STAINLESS STEEL TOP DUTCH CLEAR DOOR			

\*See pages 4 and 5 for slide identification.  
All slides sold as pairs.

# SERVICE and REPLACEMENT PARTS (continued)

## Replacement Parts Diagram

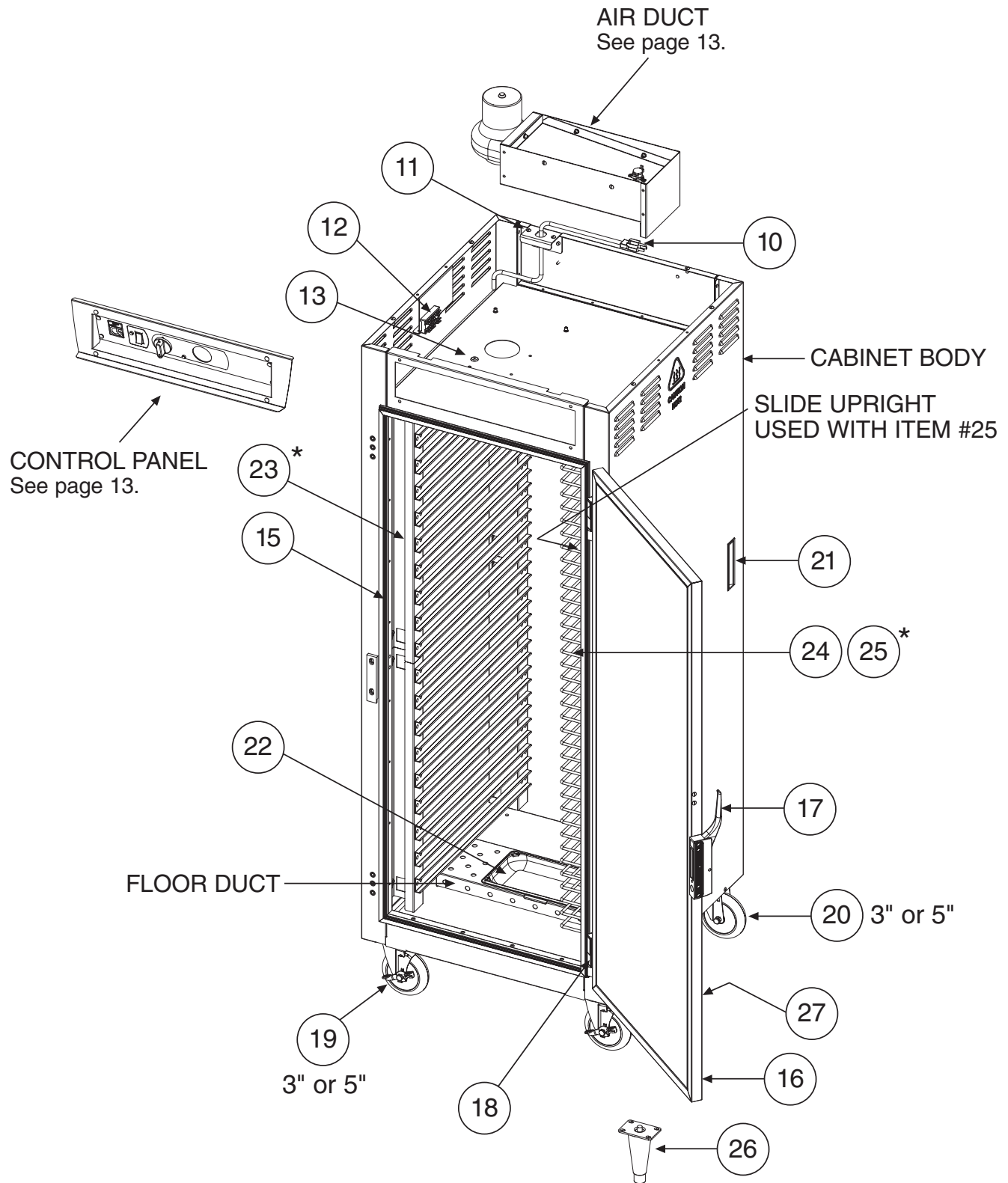

\*For slide identification, see pages 4 and 5.



# SERVICE and REPLACEMENT PARTS (continued)

**Warning:** Only factory approved service agents should attempt to service, repair or replace electrical components, wiring or power cord.

To access the electrical control area, remove the (7) screws holding the cabinet top in place. Lift the rear portion of the cabinet top and slide it away from under the front control bezel, removing it from the cabinet. After servicing, replace the cabinet top and the (7) screws holding it in place.

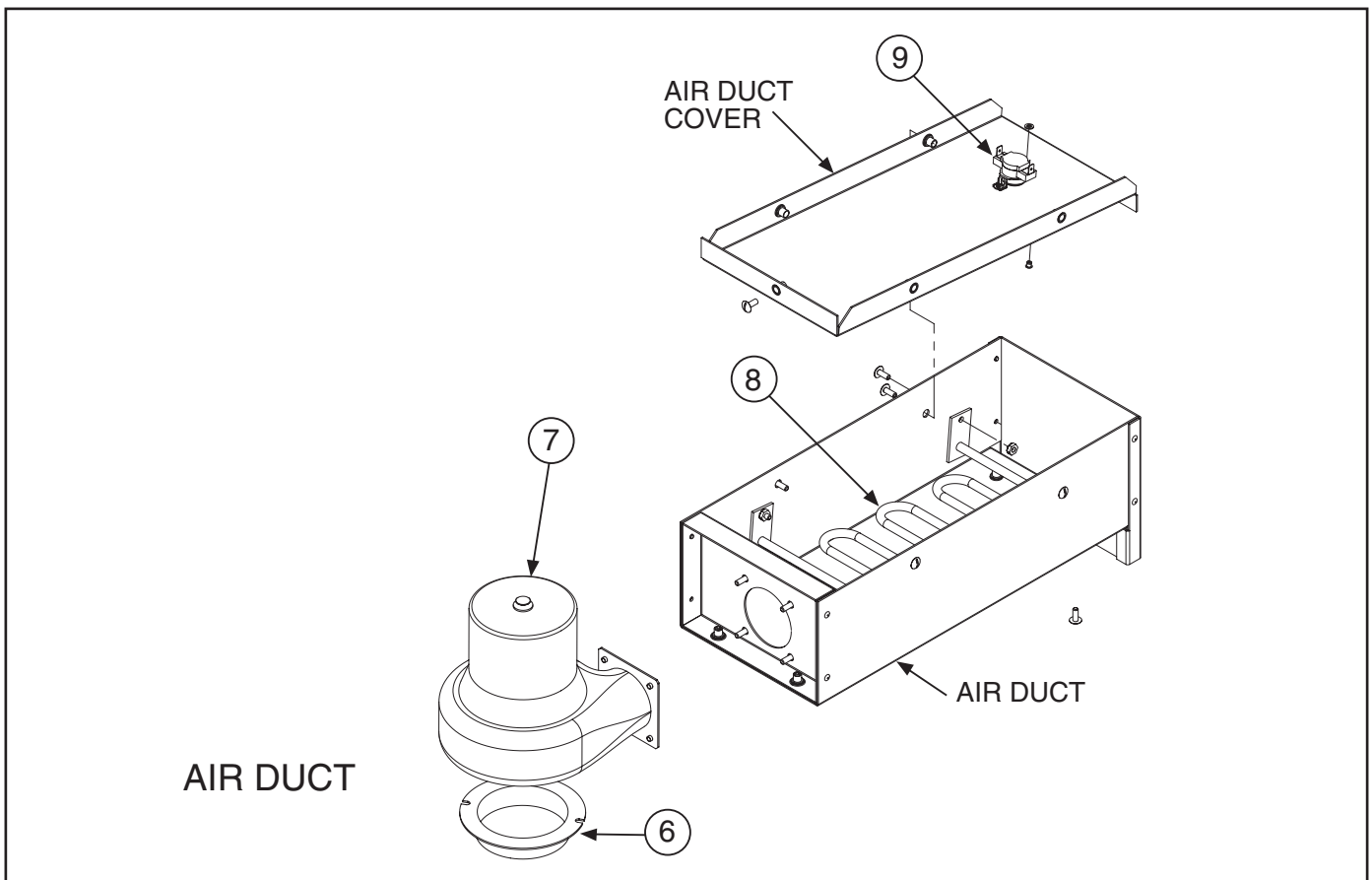
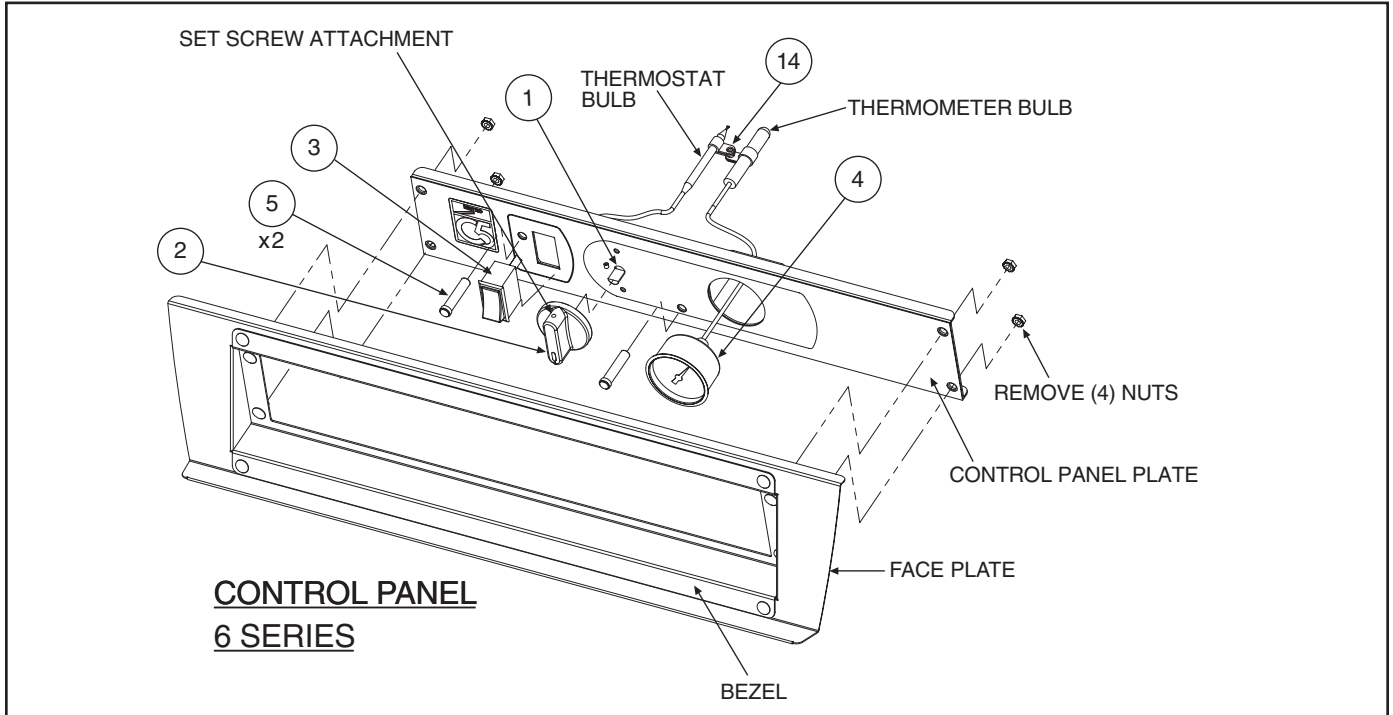



# SERVICE and REPLACEMENT PARTS (continued)

**Warning:** Only factory approved service agents should attempt to service, repair or replace electrical components, wiring or power cord.

**Wiring Diagram**

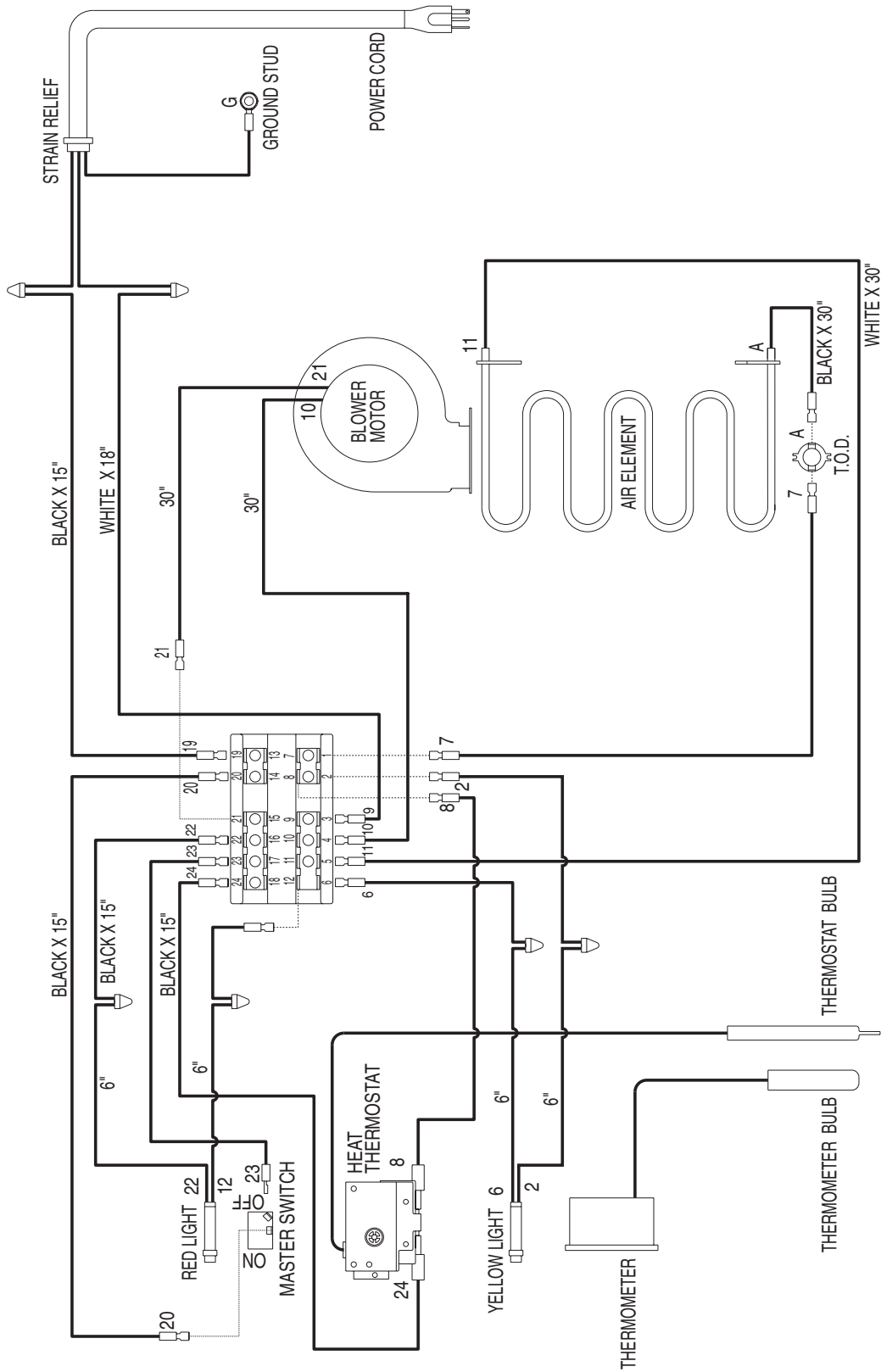

Thank you for purchasing a Metro C5 Controlled Temperature Cabinet. We are certain you will be more than satisfied with its quality and performance. Please fill in the warranty information space below so we may register your warranty. Also, so that we may learn more about our customers and hopefully be of continued service in the future, please take a moment to fill in the customer information space below.

*Thank You*

CUT ALONG DOTTED LINE

**CUSTOMER INFORMATION**

**1. Which one of the following best describes your establishment?**

- a.  Full-Service Restaurant
- b.  Banquet Hall
- c.  Hotel/Motel
- d.  Hospital/Nursing Home
- e.  College/University
- f.  School
- g.  Employee Feeding
- h.  Other \_\_\_\_\_

**WARRANTY INFORMATION:**

Cabinet Model No. \_\_\_\_\_  
 Cabinet Serial No. \_\_\_\_\_  
 Date Purchased \_\_\_\_\_  
 Customer Name \_\_\_\_\_  
 Address \_\_\_\_\_  
 \_\_\_\_\_  
 Phone No. \_\_\_\_\_

***For warranty coverage, this card must be returned to Metro.***

FOLD HERE — DO NOT DETACH

**2. Please indicate the two product benefits that were of major interest to you.**

- a.  Easy-to-use controls
- b.  Door selection
- c.  Size Selection
- d.  Cabinet capacity
- e.  Slide selection
- f.  Easy-to-clean design
- g.  Other \_\_\_\_\_

**3. Main factor that led to your decision to purchase this product?**

- a.  Product operating and functional features
- b.  Overall quality
- c.  Price
- d.  Availability
- e.  Other \_\_\_\_\_

**4. Three sources that led to the purchase of his product — in the order of their impact (1 — being most impact; 3 — being least impact).**

- a.  Trade Journal Ad
- b.  Trade Show
- c.  Sales Call
- d.  Direct Mail
- e.  Previous Purchase
- f.  Other \_\_\_\_\_

CUT ALONG DOTTED LINE



WILKES-BARRE PA 18705-9968

P O BOX A

ATTN: CUSTOMER SERVICE

INTERMETRO INDUSTRIES CORPORATION

POSTAGE WILL BE PAID BY

FIRST-CLASS/STAINLESS STEEL PERMIT NO. 121 WILKES-BARRE, PA

**BUSINESS REPLY MAIL**

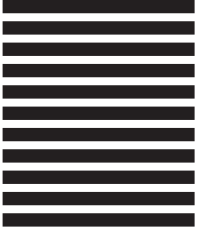

NO POSTAGE  
NECESSARY  
IF MAILED  
IN THE  
UNITED STATES

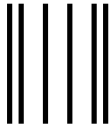

FOLD HERE — DO NOT DETACH

STAPLE HERE

STAPLE HERE

STAPLE HERE

# Warranty

## WARRANTY, EXCLUSION OF WARRANTIES AND LIMITATION OF LIABILITY.

InterMetro Industries Corporation (hereinafter referred to as "Seller") warrants to the original purchaser that all products in its catalog, or custom products, delivered hereunder will be free from defects in workmanship and material. THE FOREGOING WARRANTY IS EXCLUSIVE AND IN LIEU OF ALL OTHER WARRANTIES, EXPRESS, IMPLIED OR STATUTORY, INCLUDING ANY WARRANTY OF MERCHANTABILITY OR FITNESS FOR A PARTICULAR PURPOSE. This Warranty shall be for a period of one (1) year from the date of shipment from Seller's warehouse or factory. If any product delivered hereunder does not meet the Warranty specified above, providing the product has not been altered in any way by anyone other than Seller's factory-authorized representative, and assuming normal and proper use and maintenance, Seller will, at its option, repair or replace any part or material it determines, upon inspection, to be defective; provided however, that a charge for labor will be made except during a period of one (1) year from the date of original shipment from Seller's warehouse or factory. No product, or part thereof, is to be returned to Seller without prior written approval from Seller's factory. All exchanges and replacement shipments will be F.O.B. Seller's factory. Warranties for equipment or articles not manufactured by the Seller are solely the warranties of the manufacturers thereof and they are hereby assigned to the purchaser without recourse to the Seller.

SELLER'S LIABILITY FOR ANY CLAIM OF ANY KIND, WHETHER BASED ON CONTRACT, NEGLIGENCE OR STRICT LIABILITY IN TORT, AND BY WHOMEVER MADE, FOR ANY DIRECT, INDIRECT, INCIDENTAL OR CONSEQUENTIAL LOSS, DAMAGE OR INJURY, RESULTING TO THE PURCHASER OR ANY THIRD PARTIES, arising out of, connected with or resulting from this Agreement, or from the performance or breach thereof, or from the manufacture, sale, delivery, resale, installation, inspection, repair or use of any product covered by or furnished under this Agreement, WHETHER OR NOT CAUSED BY SELLER'S NEGLIGENCE, SHALL IN ALL EVENTS BE EXCLUSIVELY LIMITED TO THE COST OF CORRECTING DEFECTIVE, DAMAGED OR NON-CONFORMING PARTS OR MATERIAL AS HEREIN PROVIDED, and upon the expiration of one (1) year, all such liability shall terminate.

SELLER DOES NOT AUTHORIZE any person to assume for it any obligations or liabilities greater than or different than those set forth in this Warranty. The terms under which any of Seller's products may be resold must be limited in accordance with this Warranty.

THIS AGREEMENT, and all the rights and obligations arising hereunder, shall be construed in accordance with, and be governed by, the law of the Commonwealth of Pennsylvania, U.S.A.

TO INSURE WARRANTY implementation, return the completed registration card within 15 days of cabinets' receipt to: InterMetro Industries Corp., Wilkes-Barre, PA 18705



InterMetro Industries Corporation  
Wilkes-Barre, PA 18705



**InterMetro Industries Corporation**

North Washington Street, Wilkes-Barre, PA 18705

For Product Information Call: 1-800-433-2232

Visit Our Web Site: [www.metro.com](http://www.metro.com)

L01-427

07/06

Information and specifications are subject to change  
without notice. Please confirm at time of order.