

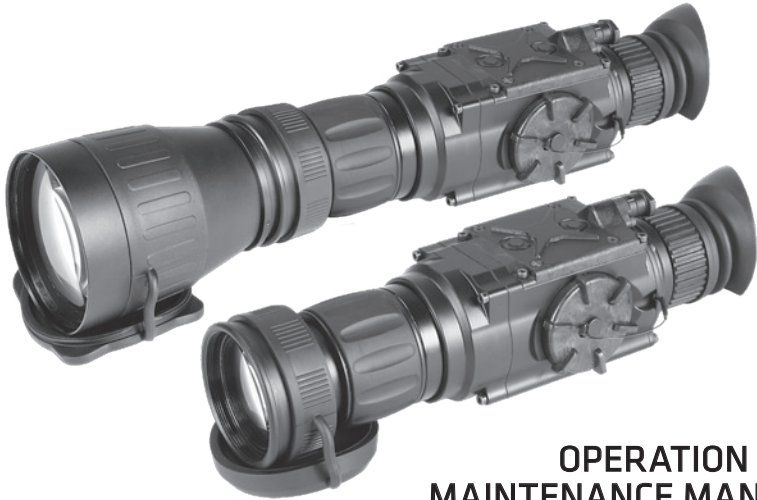

# BIT 5X BIT 5X-10X

Digital Night Vision Monoculars



## OPERATION AND MAINTENANCE MANUAL

**Important Export Restrictions!** Commodities, products, technologies and services of this manual are controlled by the U.S. Department of State Office of Defense Trade Controls, in accordance with International Traffic in Arms (ITAR), Title 22, Code of Federal Regulations Part 120-130 and/or by the Export Administration Regulations (EAR) of U.S. Department of Commerce. At any time when a license or a written approval of the U.S. Government is applicable to it, it is illegal and strictly forbidden to export, intend to export, transfer in any other manner whatsoever, sell any hardware or technical data, provide any associated service to any non-U.S. resident, beyond or within the United States territory, until the valid license or written approval has been issued by the Departments of the U.S. Government having jurisdiction. Additionally U.S. law prohibits the sale, transfer, or export of items to certain restricted parties, destinations, and embargoed countries, as identified on lists maintained by the U.S. Department of State, the U.S. Department of Commerce, and the U.S. Department of Treasury. It is the responsibility of the Customer to be aware of these lists. The sale, transfer, transportation, or shipment outside of the U.S. of any product prohibited or restricted for export without complying with U.S. export control laws and regulations, including proper export licensing, documentation or authorization, is unlawful and may result in civil and/or criminal penalties and/or constitute a federal crime. Diversion contrary to U.S. law is strictly prohibited.



## SAFETY SUMMARY

Before operating this product, you must carefully study this Operation and Maintenance Manual.

The Armasight Bit Digital Night Vision Monocular is a precision electro-optical instrument and requires careful handling. To avoid physical danger to the user and damage to the equipment, follow all WARNINGS, CAUTIONS and NOTES.

Below are definitions of the alerts that will appear throughout this Manual:

**WARNING** – Identifies clear danger to the person operating the equipment.

**CAUTION** – Identifies risk of damage to the equipment.

**NOTE** – Highlights essential procedures, conditions, and statements, or conveys important instructional data to the user.

The information provided in this manual is for familiarization purposes only. The contents may undergo further changes with no commitment by Armasight® to notify customers of any updates.

Armasight® assumes no responsibility for any misprints or other errors that this manual may contain.

©2013 by Armasight. All rights reserved.

**WARNINGS:**

**This product contains natural rubber latex, which may cause allergic reactions!** The FDA has reported an increase in the number of deaths that are associated with an apparent sensitivity to natural latex proteins. If you are allergic to latex, it is a good idea to learn which products contain it and strictly avoid exposure to those products.

**CAUTION:**

- Do not dismantle the equipment.
- Keep the equipment clean. Protect it from moisture, dramatic temperature drops, and electrical shocks.
- DO NOT force the equipment controls past their stopping points.
- DO NOT leave the equipment activated during breaks in operation.
- DO NOT store the equipment with the batteries installed.
- Thoroughly clean and dry each item before placing them into the storage case.

**CAUTION:**

Although the equipment is highly resistant to damage from light overload, DO NOT point it, either powered or un-powered, directly at the sun or any other source of high intensity light that the unprotected human eye cannot tolerate (such as welding arc). To prevent inadvertent exposure to these light sources, never leave the equipment unsupervised with the objective lens cap removed.

**NOTES:**

- DO NOT remove the batteries or disconnect the external power source while the Bit is on.
- Inadvertent sun damage is not considered a defect in material or workmanship, and is therefore not covered in the product warranty.

# LIST OF CONTENTS

TITLE	PAGE
<b>Safety Summary</b>	2
<b>List of Contents</b>	4
<b>List of Figures</b>	5
<b>List of Tables</b>	6
<b>How to Use This Manual</b>	6
<b>1. INTRODUCTION</b>	<b>7</b>
<b>1.1 General Information</b>	7
1.1.1 Type of Manual	7
1.1.2 Model Number and Equipment Name	7
1.1.3 Purpose of Equipment	7
1.1.4 Reporting Equipment Improvement Recommendations	8
<b>1.2 Warranty Information and Registration</b>	8
1.2.1 Warranty Information	8
1.2.2 Limitation of Liability	8
1.2.3 Product Warranty Registration	9
1.2.4 Obtaining Warranty Service	9
<b>1.3 List of Abbreviations</b>	10
<b>2. DESCRIPTION AND DATA</b>	<b>11</b>
<b>2.1 System Description</b>	11
<b>2.2 Bit Specifications</b>	12
<b>2.3 Standard Components</b>	14
<b>2.4 Optional Equipment</b>	16
<b>2.5 Key Features</b>	17
<b>3. OPERATING INSTRUCTIONS</b>	<b>18</b>
<b>3.1 Installation and Mounting</b>	18
3.1.1 Battery Installation	18
3.1.2 Mounting a Platform Ring to the Bit	18
3.1.3 Fastening an Advanced Wireless Remote Control	19
3.1.4 Installing Additional Equipment on the Bit	19
3.1.5 Connecting Additional Equipment to the Bit	20
3.1.6 Installing an IR Illuminator on the Bit	21
3.1.7 Attaching an Afocal Doubler to the Bit	22
3.1.8 Installing the Bit on a Tripod	22
<b>3.2 Controls and Display Indications</b>	23
3.2.1 Bit Controls	23
3.2.2 IR Illuminator Controls	24
<b>3.3 Operating Procedures</b>	24
3.3.1 Operating the Bit	24
3.3.2 Operating an IR Illuminator	25
3.3.3 Bit Shut-Down	26

<b>4. PREVENTIVE MAINTENANCE AND TROUBLESHOOTING</b>	<b>27</b>
<b>4.1 Preventive Maintenance Checks and Services</b>	27
4.1.1 Preventive Maintenance Checks and Services (PMCS)	27
<b>4.2 Operator Troubleshooting</b>	29
<b>4.3 Maintenance</b>	29
4.3.1 General	29
4.3.2 Cleaning Procedures	30
4.3.3 Battery Removal and Replacement	30
<b>4.4 Return Instructions</b>	<b>31</b>
<b>APPENDIX</b>	<b>32</b>
<b>A List of Spare Parts</b>	32
<b>B Product Warranty Registration Card</b>	33

## LIST OF FIGURES

FIGURE	TITLE	PAGE
2-1	Bit Digital Night Vision Monoculars Appearance	11
2-2	Bit Digital Night Vision Monocular. System Description	12
2-3	Bit Standard Components	14
2-4	Optional Equipment	16
3-1	Battery Installation	18
3-2	The Bit Fully Assembled with the Platform Ring	19
3-3	Platform Ring	19
3-4	Advanced Wireless Remote Control	19
3-5	Armasight DT Digital Recorder Installation	20
3-6	Video Cable	20
3-7	IR Illuminator	21
3-8	IR Illuminator. Battery Installation	21
3-9	The Bit with the Afocal Doubler Attached	22
3-10	Bit Controls	23
3-11	IR Illuminator Controls	24
3-12	IR Illuminator Adjustment	25
4-1	Advanced Wireless Remote Control Battery Installation	30
A-1	Bit Spare Parts List	32

## LIST OF TABLES

TABLE	TITLE	PAGE
2-1	Bit System Description	12
2-2	System Data	12
2-3	Mechanical Data	13
2-4	Optical Data	13
2-5	Electrical Data	13
2-6	Environmental Data	14
2-7	IR850W Illuminator Data	14
2-8	Bit Standard Components	15
2-9	Optional Equipment	16
3-1	Controls and Indicators	23
3-2	IR Illuminator Controls	24
4-1	Preventive Maintenance Checks and Services	27
4-2	Operator Troubleshooting	29
A-1	Bit Spare Parts List	32

## HOW TO USE THIS MANUAL

### USAGE

You must familiarize yourself with the entire manual before operating the equipment. Read the entire maintenance checklist before performing maintenance. Follow all **WARNINGS**, **CAUTIONS**, and **NOTES**.

### MANUAL OVERVIEW

The Manual contains sections on operating and maintaining the Bit Digital Night Vision Monocular.

Throughout this Manual, the Bit Digital Night Vision Monocular will be referred to as the Bit or the equipment.

A List of Spare Parts is in Appendix A.

The Product Warranty Registration Card is in Appendix B.

# INTRODUCTION

## 1.1 GENERAL INFORMATION

### 1.1.1 TYPE OF MANUAL

Operation and Maintenance (including a List of Spare Parts).

### 1.1.2 MODEL NUMBER AND EQUIPMENT NAME

Bit 5x Digital Night Vision Monocular.

Bit 5x-10x Digital Night Vision Monocular.

### 1.1.3 PURPOSE OF EQUIPMENT

The Bit is a professional grade, Digital Night Vision Monocular with optical 5x or 10x magnification, making it the most powerful monocular in its class. Sensitive to both near-infrared and visible light, the high performance CCD imaging system of the Bit provides round-the-clock observation. The Bit is effective regardless of light conditions - in daylight, in natural lighting, and at nighttime. The Bit is an ideal product for both professional and amateur use, such as hunting, security, law enforcement, general nighttime observation, and recording.

The Bit is available in two versions, with magnifications of 5x and 10x. The magnification of the Bit 5x can be changed to 10x by using an optional afocal lens attachment.

The Bit is powered by two CR 123A (2x3V) batteries. An external battery supply or 6 VDC/1A power source can also be used to power the Bit.

The Bit can be controlled by a wireless remote control.

A detachable, long-range IR illuminator provides additional lighting and enables the use of the Bit in extremely low light conditions or total darkness.

The Bit is equipped with a standard NTSC/PAL video input/output function that makes it possible to connect to an external video monitor, or to record images for field documentation or training purposes. It also allows the transmission of data from a remote display to that of the Bit.

The Bit can be used in conjunction with other Armasight equipment, such as the Recorder DT Digital Video Recorder and External Battery Power Supply. The additional equipment can be mounted onto the Bit's Picatinny/Weaver rail or detachable platform ring.

Extremely reliable and versatile, the Bit is a valuable, multifunctional addition to any security or hunting.

## 1.1.4 REPORTING EQUIPMENT IMPROVEMENT RECOMMENDATIONS

User recommendations for improvements to the device are encouraged.

Mail your comments to:

Armasight Inc.

815 Dubuque Avenue

South San Francisco, CA 94080

USA

Or, send an email to [info@armasight.com](mailto:info@armasight.com).

## 1.2 WARRANTY INFORMATION AND REGISTRATION

### 1.2.1 WARRANTY INFORMATION

This product is guaranteed to be free from manufacturing defects in material and workmanship under normal use for a period of two (2) years from the date of purchase. This warranty does not cover the battery or damage caused by leaking batteries, nor does it protect against damage due to loss, misuse or mishandling.

In the event a defect that is covered by the warranty occurs during the 2 year period stated above, Armasight, at its option, will either repair or replace the product, and such action on the part of Armasight shall be the full extent of Armasight's liability, and the Customer's sole and exclusive remedy. This warranty does not cover a product (a) used in other than its normal and customary manner; (b) subjected to misuse; (c) subjected to alterations, modifications or repairs by the Customer or by any party other than Armasight without prior written consent of Armasight; (d) special order or "close-out" merchandise or merchandise sold "as-is" by either Armasight or the Armasight dealer; or (e) merchandise that has been discontinued by the manufacturer and either parts or replacement units are not available due to reasons beyond the control of Armasight. Armasight shall not be responsible for any defects or damage that in, Armasight's opinion, is a result from the mishandling, abuse, misuse, improper storage or improper operation, including use in conjunction with equipment which is electrically or mechanically incompatible with or of inferior quality to the product, as well as failure to maintain the environmental conditions specified by the manufacturer.

This warranty is extended only to the original purchaser. Any breach of this warranty shall be waived unless the customer notifies Armasight at the address noted below within the applicable warranty period.

The customer understands and agrees that except for the foregoing warranty, no other warranties written or oral, statutory, expressed or implied, including any implied warranty of merchantability or fitness for a particular purpose, shall apply to the product. All such implied warranties are hereby and expressly disclaimed.

### 1.2.2 LIMITATION OF LIABILITY

Armasight will not be liable for any claims, actions, suits, proceedings, costs, expenses, damages or liabilities arising out of the use of this product. Operation and use of the product are the sole responsibility of the Customer. Armasight's sole undertaking is limited to providing the products and services outlined herein in accordance with the terms and conditions of this Agreement. The provision of products sold and services performed by Armasight to the Customer shall not be interpreted, construed, or regarded, either expressly or implied, as being for the benefit of or creating any obligation toward any third party or legal entity outside Armasight and the Customer. Armasight's obligations under this Agreement extend solely to the Customer.

Armasight's liability hereunder for damages, regardless of the form or action, shall not exceed the fees or other charges paid to Armasight by the customer or customer's dealer. Armasight shall not, in any event, be liable for special, indirect, incidental, or consequential damages, including, but not limited to, lost income, lost revenue, or lost profit, whether such damages were foreseeable or not at the time of purchase, and whether or not such damages arise out of a breach of warranty, a breach of agreement, negligence, strict liability or any other theory of liability.



### **1.2.3 PRODUCT WARRANTY REGISTRATION**

In order to validate the warranty on your product, Armasight must receive a completed Product Warranty Registration Card for each unit, or the Customer can complete a warranty registration on our website at [www.armsight.com](http://www.armsight.com). Please complete the included form (Appendix B) and immediately mail it to our Service Center:

Armasight Inc.  
815 Dubuque Avenue  
South San Francisco, CA 94080  
USA

### **1.2.4 OBTAINING WARRANTY SERVICE**

To obtain warranty service on your unit, the End-user must notify the Armasight's service department in order to receive a Return Merchandise Authorization number (RMA#). The customer can do this by sending an email to [service@armsight.com](mailto:service@armsight.com).

When returning any product, please take or send the product, postage paid, with a copy of your sales receipt, to our service center, Armasight Inc. at the address noted above. All merchandise must be fully insured with the correct postage; Armasight will not be responsible for improper postage or missing or damaged merchandise during shipment.

When sending merchandise back, please write the RMA# clearly on the outside of the shipping box. Please include a letter that indicates your RMA#, Name, Return Address, reason for service return, Contact information (such as a valid telephone number and/or e-mail address), as well as proof of your purchases that will help us to establish the valid start date of the warranty. Product merchandise returns that do not have an RMA listed may be refused or be subject to a significant delay in processing.

Estimated Warranty service time is 10-20 business days. The End-user/Customer is responsible for postage to Armasight for any warranty service. Armasight will cover return postage/shipping to continental USA End-users/Customers after warranty repair only if product is covered by the aforementioned warranty. Armasight will return the product after warranty service via domestic ground service and/or domestic mail. The postage and shipping fees for any other requested, required or international shipping methods will be the responsibility of the End-user/Customer.

## 1.3 LIST OF ABBREVIATIONS

$\mu\text{m}$	micrometer
AWREC	Advanced Wireless Remote Control
C	Celsius (Centigrade)
CCW	counterclockwise
CW	clockwise
F	Fahrenheit
FL	Focal Length
g	gram
H	Height
hr	hour
in	inch
inf.	infinity
kg	kilogram
L	Length
lbs	pounds
m	meter
mA	milliampere
mil	angular mil
min	minute
mm	millimeter
MOA	Minute Of Angle
mrad	milliradian
NO.	Number
NTSC	National Television Standards Committee
oz	ounce
PAL	Phase Alternating Line
PMCS	Preventive Maintenance Checks and Services
RMA#	Return Merchandise Authorization number
sec	second
SEQ	sequence
SOA	Second Of Angle
SR	Service Representative
V	Volt
W	Width

# DESCRIPTION AND DATA

## 2.1 SYSTEM DESCRIPTION

The Bit consists of next primary parts: a body, a lens assembly and a eyepiece assembly. The equipment comes as shown in Figure 2-1. The figure represents the both 5x and 5x-10x versions of the Bit.

The Bit is a highly light-sensitive device. The Bit sensor (CCD array) reacts to near-infrared and visible light and converts the received light into electric charges. The controlling circuit converts the entire contents of the two-dimensional array to a sequence of voltages that are processed into a continuous analog signal. The Bit displays, as a result, a real-time images corresponding to the scene projected onto the focal plane of the sensor.

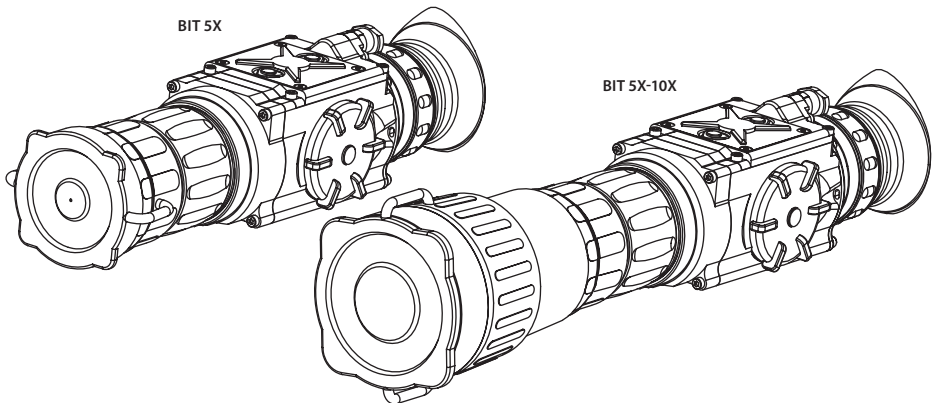

**FIGURE 2-1. BIT DIGITAL NIGHT VISION MONOCULARS APPEARANCE**

The main optical-electronic components of the Bit include: an objective lens, an eyepiece, a CCD camera, a display, a control card, and a button control panel.

The Bit is equipped with a manually adjustable eyepiece, focusable objective lens, and a digitally controlled display brightness.

Information on the battery status is continuously displayed.

Manufactured for exceptional durability, the Bit has a lightweight and robust aluminum body.

A side Picatinny/Weaver rail allows for the installation of an optional Armasight DT Digital Video Recorder, extended battery supply, or other equipment.

A detachable Platform Ring makes it possible to mount an IR illuminator or other additional equipment to the top of the device.

A detachable, long-range IR illuminator provides additional lighting and enables the use of the Bit in extremely low light conditions or total darkness.

A standard NTSC/PAL video input/output connector enables an external video display (monitor, TV) or video recorder to be connected to the Bit. An external battery power supply or 6 VDC/1A power source can also be connected to the Bit.

The Bit is powered by two CR 123A (2×3V) batteries.

The Bit is shown in Figure 2-2. The ITEM NO. column of Table 2-1 indicates the number used to identify items in Figure 2-2.

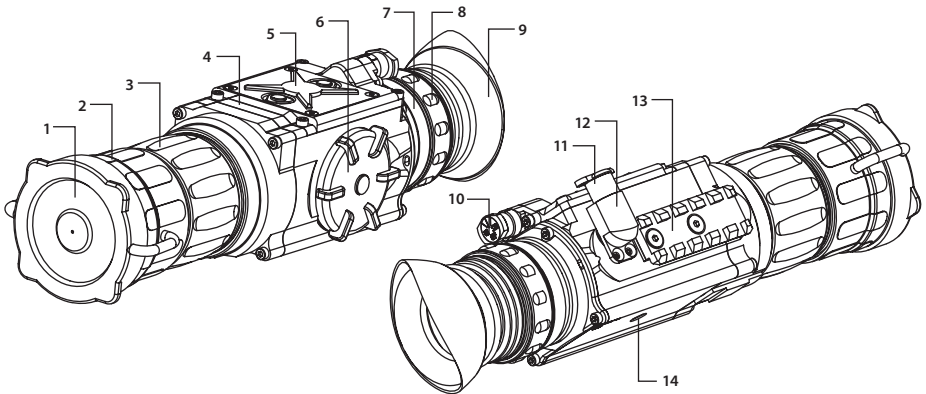

**FIGURE 2-2. BIT DIGITAL NIGHT VISION MONOCULAR. SYSTEM DESCRIPTION**

**TABLE 2-1. BIT SYSTEM DESCRIPTION**

ITEM	DESCRIPTION	ITEM	DESCRIPTION
1	Objective Lens Cap	8	Eyepiece Focus Ring
2	Objective Lens	9	Eyecup
3	Objective Focus Ring	10	Turn-pull Switch
4	Body	11	Connector Cap
5	Button Control Panel	12	Connector
6	Battery Cap	13	Side Picatinny/Weaver Rail
7	Eyepiece	14	Tripod Socket

## 2.2 BIT SPECIFICATIONS

**TABLE 2-2. SYSTEM DATA**

ITEM	BIT 5X	BIT 5X-10X
CCD Camera	High-rate High Resolution Near-IR Hypersensitive CCD Camera	
Pixel CCD Array Format	752×582	
CCD Array Spectral Response	0.4 to 1.1 μm	
Resolution	30 SOA	15 SOA
Display Type	AMOLED SVGA 060	
Pixel Display Format	800×600	

**TABLE 2-2. CONTINUED**

ITEM	BIT 5X	BIT 5X-10X
Display Brightness	Discretely Adjustable to 8 Levels	
Turn-on Time, max	3 sec	
Analog Input Format	PAL/ NTSC	
Analog Output Format	PAL	
PAL Output Resolution	768×574 pixels	

**TABLE 2-3. MECHANICAL DATA**

ITEM	BIT 5X	BIT 5X-10X
Overall Dimensions	240×69×65mm (9.4"×2.7"×2.6")	335×70×74mm (13.2"×2.8"×2.9")
Weight (w/o Batteries)	0.74 kg (1.6 lbs)	1.07 kg (2.4 lbs)

**TABLE 2-4. OPTICAL DATA**

ITEM	BIT 5X	BIT 5X-10X
Magnification	5x (10x with optional Afocal Doubler)	5x or 10x (10x with included Afocal Doubler)
Field of View	- ang. X degrees - ang. Y degrees	3.2° (with Afocal Doubler) 2.3° (with Afocal Doubler)
Objective Focal Length	50mm	90mm (with Afocal Doubler)
Objective F-number	1:1.2	1:1.4 (with Afocal Doubler)
Eyepiece Focal Length	25 mm	
Entrance Pupil Diameter	42mm	65mm
Exit Pupil Diameter	10 mm	
Eye Relief	45 mm	
Focus Method	Manual	
Focusing Range	10m to infinity	10m to infinity
Diopter Adjustment	Manual	
Diopter Adjustment Range	±5 diopter	

**TABLE 2-5. ELECTRICAL DATA**

ITEM	DATA
Battery	Two CR123A Lithium 3V or CR123 type rechargeable batteries with voltage 3.2V
Current Consumption, maximum	500 mA
Battery Life at 20 °C (68 °F)	up to 3 hr
External Battery Power Supply 1	Four AA Lithium batteries (1.5V) or AA rechargeable batteries (1.2V) / Operational Time up to 3.5 hr
External Battery Power Supply 2	Two 18650 rechargeable batteries (3.7V) or four CR123 type rechargeable batteries with voltage 3.7V max. / Operational Time up to 7 hr
External Power Supply	6 VDC / 1 A

**TABLE 2-6. ENVIRONMENTAL DATA**

ITEM	DATA
Operating Temperature	-40 to +50°C (-40 to +122°F)
Storage Temperature	-50 to +70°C (-58 to +158°F)
Recoil Resistance	700g
Immersion	10m for 30 min

**TABLE 2-7. IR850W ILLUMINATOR DATA**

ITEM	DATA
IR Emitter Type	LED
Power	500 mW
Peak Wavelength	850 nm
Illumination Range	up to 500 m
Divergence	2 to 30°
Battery	Single CR123A Lithium battery (3V) *
Battery Life at 20 °C (68 °F)	From 1.5 hr (Full Power) to 10 hr (1/4 Power)
Overall Dimensions (with Mount)	120x42x38 mm (4.7"x1.6"x1.5")
Weight (with Mount, without Battery)	102 g (3.6 oz)
Operating Temperature	-30 to +50°C (-22 to 122°F)
Storage Temperature	-50 to +70°C (-58 to 158°F)
Environmental Rating	Water Resistant

\* Any CR123 type rechargeable batteries with voltage from 3.0V to 3.7V can be used

## 2.3 STANDARD COMPONENTS

The Bit standard components are shown in Figure 2-3 and listed in Table 2-8. The ITEM NO. column indicates the number used to identify items in Figure 2-3.

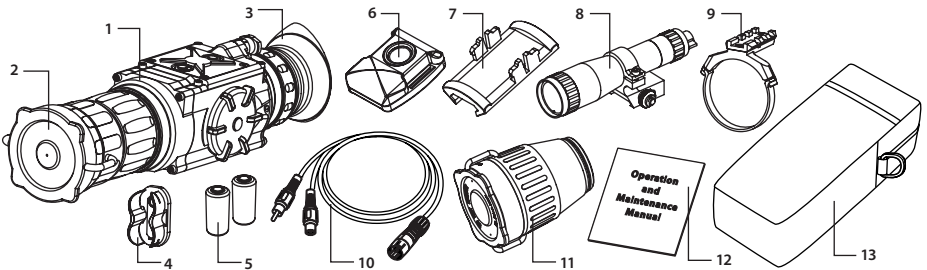

**FIGURE 2-3. BIT STANDARD COMPONENT**

**TABLE 2-8. BIT STANDARD COMPONENTS**

ITEM NO.	DESCRIPTION	QUANTITY
1	<b>Armasight Bit Digital Night Vision Monocular</b> A Digital Night Vision device.	1
2	<b>Objective Lens Cap</b> Protects the objective lens from dirt and mechanical damage, and provides protection from light overload. Comes attached to the objective lens.	1
3	<b>Eye-cup</b> A rubber cup used to protect the eyepiece as well as provide comfort for the operator. Comes attached to the eyepiece.	1
4	<b>Battery Cassette</b> Intended for the installation of two CR123 batteries in the battery compartment. The Bit comes with two battery cassettes (includes one installed in the battery compartment and one spare cassette).	2
5	<b>CR123A Lithium Battery</b> Batteries are used to power the Bit.	2
6	<b>Advanced Wireless Remote Control (AWREC)</b> Allows the user to operate the Bit in remote activation mode. Ensures quick and silent activation/deactivation of the equipment. Comes with CR2032 (3V) battery installed.	1
7	<b>Picatinny Adapter for Advanced Wireless Remote Control</b> Allows the advanced wireless remote control to be installed on a weapon's Picatinny/Weaver rail.	1
8	<b>IR850W Detachable Wide Angle Adjustable X-Long Range Infrared Illuminator</b> A detachable LED long-range infrared illuminator with a wide, adjustable beam angle. Compatible with night vision devices that rely on CCD or image intensifier technology. Should be used when there is little to no ambient light. Comes fully assembled with a dedicated mount in order to be installed on a Picatinny/Weaver rail.	1
9	<b>Platform Ring</b> A dedicated mount with a Picatinny/Weaver rail, used to install on the top of the Bit and additional equipment, such as the Armasight MCS Miniature Collimating Sight.	1
10	<b>Video Cable</b> A cable used to connect the analog video input/output of the Bit to external display devices (a monitor, TV) or power sources. The cable plug A is used for video, the plug B is used for external power surge connection.	1
11	<b>Afocal Doublor (Bit 5X-10X only)</b> 2x magnifying lens intended for long-range operation. Comes complete with an thread adapter and three M2x3 screws that are required to mount the lens to the Bit.	1
12	<b>Operation and Maintenance Manual</b> Provides safety information, equipment description, mounting procedures, operating instructions, and preventive maintenance checks and services (including a List of Spare Parts).	1
13	<b>Carrying Case</b> A textile bag used for the transportation and storage of the Bit and its accessories.	1

## 2.4 OPTIONAL EQUIPMENT

Optional items are shown in Figure 2-4 and listed in Table 2-9.

The ITEM NO. column indicates the number used to identify items in Figure 2-4.

The PART NO. column indicates the primary number used by the manufacturer, to identify an item.

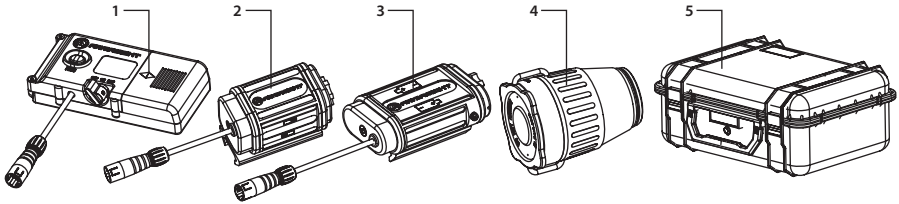

**FIGURE 2-4. OPTIONAL EQUIPMENT**

**TABLE 2-9. OPTIONAL EQUIPMENT**

ITEM NO.	DESCRIPTION	PART NO.
1	<b>Digital Video Recorder DT</b> A compact digital video recorder used for video recording, storage and playback. Can also serve as an external power source. Equipped with a remote control.	ATAM000004
2	<b>External Battery Power Supply 1</b> The power source for extended operational time. Takes four AA batteries (1.5V) or AA rechargeable batteries (1.2V).	ATAM000007
3	<b>External Battery Power Supply 2</b> The power source for extended operational time. Takes four CR123A Lithium batteries (1.5V) or CR123 type rechargeable batteries (3.2V or 3.7V) or two 18650 type rechargeable batteries (3.7V).	ATAM000008
4	<b>Afocal Doublor for Bit 5X</b> An accessory 2x magnifying lens intended for long-range operation. Comes complete with an thread adapter and three M2x3 screws that are required to mount the lens to the Bit 5X.	ANAF18X039
5	<b>Hard Shipping/Storage Case</b> A protective case used for the shipping/storage of the Bit and its accessories.	ANHC000004



## 2.5 KEY FEATURES

- Available in two versions — with magnification of 5x and 10x
- High-performance CCD camera
- Bright-light tolerance
- An effective regardless of light conditions - in daylight, in natural lighting, and at nighttime.
- Lightweight and robust design
- Easy to operate
- Manually adjustable eyepiece and objective lens
- Real-time display
- Digitally controlled display brightness
- Indication of the battery status information on the display
- Wireless remote control
- Analog video input (NTSC/PAL) and output (PAL)
- Powered by two standard CR123A batteries
- Power input capability
- Tripod mountable
- Digital video recorder (optional)
- Serviceability under severe conditions
- Filled with dry nitrogen to prevent internal fogging
- Waterproof
- Limited two-year warranty

# OPERATING INSTRUCTIONS

## 3.1 INSTALLATION AND MOUNTING

### 3.1.1 BATTERY INSTALLATION

**CAUTION:**

Before installing a battery, verify that the equipment is off.

Install two CR123A batteries as follows (refer to Figure 3-1):

1. Unscrew the battery cap (A).
2. Remove the battery cassette (B).
3. Insert the batteries (C) into cassette. Align the polarity symbols on the batteries with the polarity symbols on the cassette.
4. Insert the cassette with installed batteries to place.
5. Replace the battery cap.

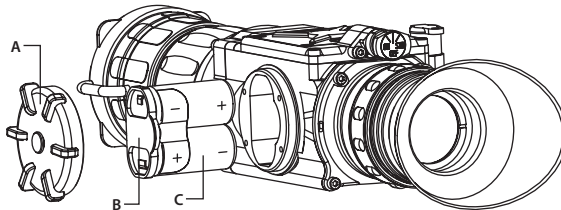

**FIGURE 3-1. BATTERY INSTALLATION**

### 3.1.2 MOUNTING A PLATFORM RING TO THE BIT

Figure 3-2 shows the Bit with the Platform Ring adapter (A) installed.

To mount the Platform Ring on the Bit, do the following (refer to Figure 3-3):

1. Using a 1.5 hex key, unscrew the both clamp screws (C).
2. Place the clamps (B, D) onto the mounting tube (as in Figure 3-2). Screw the clamps together without tightening the screws (C).
3. Adjust position of the Platform Ring until its rail (A) is level. Apply a small amount of thread lock to the threads and tighten the screws (C).

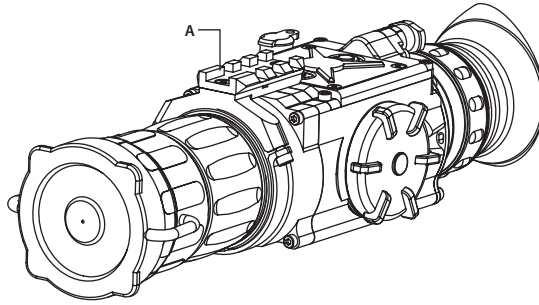

**FIGURE 3-2. THE BIT FULLY ASSEMBLED WITH THE PLATFORM RING**

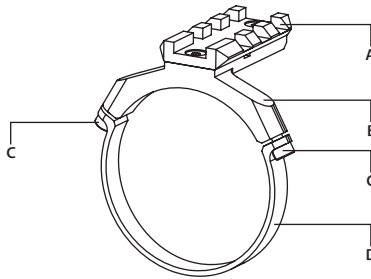
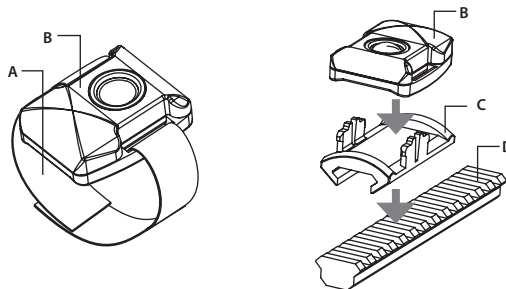

**FIGURE 3-3. PLATFORM RING**

### 3.1.3 FASTENING AN ADVANCED WIRELESS REMOTE CONTROL

Using Velcro tape (A, Figure 3-4), fasten the remote control (B) in an easily accessible place.

If your equipment has a Picatinny or Weaver rail, you can use the Picatinny adaptor for the Advanced Wireless Remote (C). Install the adaptor onto the rail (D). Insert the remote control unit into the adaptor. You can also install the Picatinny adaptor onto the Bit side rail or onto the platform ring.



**FIGURE 3-4. ADVANCED WIRELESS REMOTE CONTROL**

### 3.1.4 INSTALLING ADDITIONAL EQUIPMENT ON THE BIT

Use the side Picatinny/Weaver rail to install any additional equipment, such as the Armasight DT digital video recorder (see Figure 3-5) or an external battery power supply.

Use the Platform Ring adapter to install any additional equipment, such as the long-range IR illuminator. For adapter mounting procedures, see Part 3.1.2.

### 3.1.5 CONNECTING ADDITIONAL EQUIPMENT TO THE BIT

**CAUTION:**

Turn off the Bit before you begin connecting/disconnecting any external equipment and before removing the batteries.

Remove the batteries before you connect any external power source.

Remove the connector protective cap.

Connect a cable of Armasight DT digital video recorder or an external battery power supply to the Bit connector.

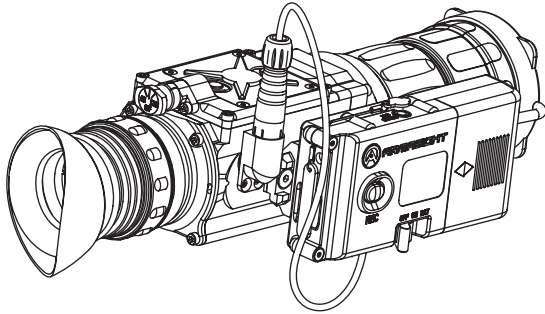

**FIGURE 3-5. ARMASIGHT DT DIGITAL RECORDER INSTALLATION**

Use the plug A of a video cable to connect an external video recorder/monitor/TV to the Bit. Connect the plug C of a video cable to the Bit connector.

Use the plug B of a video cable to connect an external power source (6 VDC/1A) to the Bit. Connect the plug C of a video cable to the Bit connector.

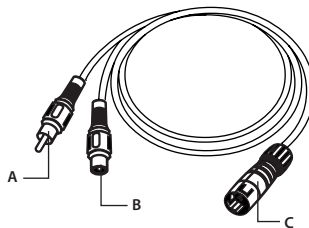

**FIGURE 3-6. VIDEO CABLE**

**NOTE:**

The external power supply must have a standard 6mm OD double-pole socket with a positive center contact.

**CAUTION:**

After removing the cable, replace the protective cap over the connector.

### 3.1.6 INSTALLING AN IR ILLUMINATOR ON THE BIT

Armasight long range IR illuminators are delivered fully assembled with a dedicated mount, to be installed on the side rail of the Bit or on the rail of the Platform Ring mounted to the Bit.

To mount an IR illuminator on a Picatinny/Weaver rail, do the following (refer to Figure 3-7):

1. With the nut (A) loosened, install the mount (B) on the Weaver rail so that the stop (C) slides into one of the transverse slots of the rail.
2. Tighten the nut (A) using a screwdriver.

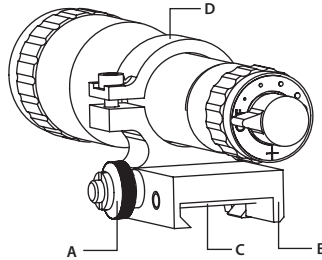

**FIGURE 3-7. IR ILLUMINATOR**

**NOTE:**

The mount clamp (D) has a spherical hinge that allows to tilt the IR illuminator mounted on the rail.

Install the CR123A battery as follows (refer to Figure 3-8):

**CAUTION:**

Ensure that the IR Illuminator is off before installing the battery.

1. Unscrew the battery cap (A).
2. Install the battery (B) into the battery compartment. Align the polarity symbols on the battery with those on the cap face.
3. Replace the battery cap (A).

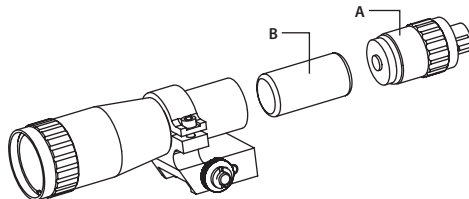

**FIGURE 3-8. IR ILLUMINATOR. BATTERY INSTALLATION**

### 3.1.7 ATTACHING AN AFOCAL DOUBLER TO THE BIT

Figure 3-9 shows the Bit with an accessory Afocal Doubler lens attached.

Attach the magnifying lens to the Bit as follows:

1. Remove the Bit objective lens cap and place it over the lens housing.
2. Screw the Afocal Doubler (A) into the threading of the Bit objective lens (B) housing. Be careful not to over-tighten the lens.

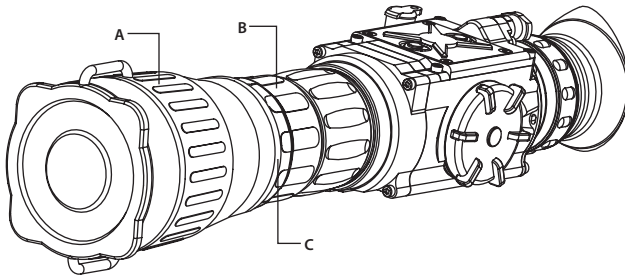

FIGURE 3-9. THE BIT WITH THE AFOCAL DOUBLER ATTACHED

#### NOTE:

The adapter (C, Figure 3-9) is used for mounting the Afocal Doubler to the Bit. The adapter is screwed to the threaded portion of the doubler housing and fixed with three M2×3 screws using a 0.9 hex key. The thread adapter switches between M48×1 and M51×1 thread sizes.

#### NOTE:

With the magnifying lens in place, magnification value changes as well as other parameters, such as system resolution, field of view, focusing range, etc.

#### NOTE:

The caution notice **DO NOT REMOVE IN DAYLIGHT** on the front lens cap of this universal magnifying lens is **not applicable** when using it on the Bit.

### 3.1.8 INSTALLING THE BIT ON A TRIPOD

The Bit can be installed to a tripod. To mount the tripod with the Bit device, screw the tripod into the 1/4" threaded socket located on the Bit's bottom side.

#### CAUTION:

The unit may be badly damaged if the tripod collapses or falls over. Remove the unit from the tripod if it is not within your reach.

## 3.2 CONTROLS AND DISPLAY INDICATIONS

### 3.2.1 BIT CONTROLS

The Bit controls are shown in Figure 3-10 and are defined in Table 3-1. The ITEM NO. columns of the tables indicate the number used to identify items in the figures.

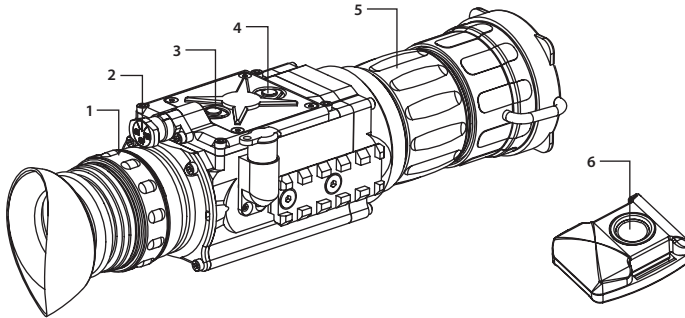

FIGURE 3-10. BIT CONTROLS

#### CAUTION:

DO NOT force the equipment controls past their stopping points.

TABLE 3-1. CONTROLS AND INDICATORS

ITEM NO.	CONTROL/INDICATOR	FUNCTION
1	Eyepiece Focus Ring	Adjusts the eyepiece diopter. The total diopter adjustment range is covered with 2 turns of the ring.
2	Turn-pull Switch	Activates the Bit when turned to ON. <b>NOTE:</b> You must pull the knob before turning in order to activate either ON or STB. Activates standby mode when turned to STB (see note above). Deactivates the Bit when turned to OFF.
3	Display Brightness Decrease Button	Push the button (3) to decrease the screen brightness.
4	Display Brightness Increase Button	Push the button (4) to increase the screen brightness.
5	Objective Focus Ring	Focuses the objective lens. Adjusts for sharpest view of the scene. The total focus range is covered with three quarter turns of the lens.
6	Remote Control Button	Activates/deactivates the Bit in standby mode. To turn the unit on, press button once, to turn it off – press button again.
—	Battery Status Indicator (a battery icon on the the display) *	The light gray bar in the battery icon indicates the current power level of the internal battery, or remaining battery life. The totally shaded battery icon indicates the fully charged battery. The flashing transparent battery icon indicates a low battery.

\* The Battery Status Indicator not show a correct power level when the external battery or power supply is used.

### 3.2.2 IR ILLUMINATOR CONTROLS

The controls of the optional IR illuminators are shown in Figure 3-11 and defined in Table 3-2. The ITEM NO. column indicates the number used to identify items in Figure 3-14.

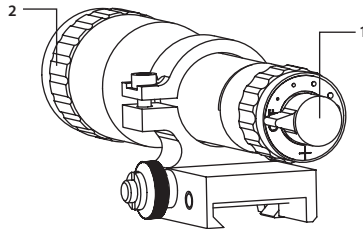

FIGURE 3-11. IR ILLUMINATOR CONTROLS

TABLE 3-2. IR ILLUMINATOR CONTROLS

ITEM NO.	CONTROL	FUNCTION
1	POWER SWITCH	Switches the IR illuminator on/off and adjusts for radiated power. Four ON positions are located between the two OFF positions, and are each marked with a different-sized spot. The larger the spot, the greater the radiated power.
2	LENS FOCUS	Adjusts for IR beam divergence. Adjustment range is covered with approximately one turn of the lens.

## 3.3 OPERATING PROCEDURES

### 3.3.1 OPERATING THE BIT

**CAUTION:**

DO NOT force the equipment controls past their stopping points.

**CAUTION:**

Although the Bit is highly resistant to damage from light overload, DO NOT point it, either powered or un-powered, directly at the sun or any other source of high intensity light that the unprotected human eye cannot tolerate (such as welding arc). To prevent exposure to these types of sources, never leave the equipment unsupervised with the objective lens cap removed.

Operating procedures are as follows:

1. Remove the Bit from the carrying case.
2. Remove the objective lens cap.
3. Point the equipment at an object.
4. Activate the Bit by turning the turn-pull switch to the ON position. After approximately 3 sec, video of the scene should appear.
5. Adjust the Bit for your eyesight by turning the eyepiece focus ring CW up to the stop, and then CCW until the display and symbols are as clear as possible. Bring the object into focus by turning the objective focus ring (CW for long-range focus, CCW for close-range focus).



**NOTE:**

The total diopter adjustment range is covered with 2 turns of the eyepiece focus ring.  
The total focus range is covered with 3/4 turn of the objective focus ring.

- Using the buttons on the control panel, adjust the brightness of the display for your comfort. Momentarily push the brightness adjustment buttons to increase/decrease the display brightness by one level at a time until you reach your desired brightness level.
- To operate the Bit with remote control, turn the switch to the STB position (standby mode). To activate the Bit, press the remote control button once. Press the remote control button again to deactivate the Bit.

**CAUTION:**

DO NOT leave the equipment activated when it is not in use.

### 3.3.2 OPERATING AN IR ILLUMINATOR

Use an IR illuminator when there is little to no ambient light.

**CAUTION:**

IR illuminator infrared light will be invisible to the naked eye. However, the light can be detected by other night vision devices.

**CAUTION:**

DO NOT leave the IR illuminator activated if it is not being used.

Operate the IR illuminator as follows:

- Turn on the IR illuminator by rotating the power switch (A) from OFF position.
- To change the radiated power level, turn the power switch to one of the spots between the two OFF positions.
- To adjust IR beam divergence, turn the lens (B).
- To adjust the IR spot position in the field of view, loosen the clamp screw (C) and tilt the IR illuminator as required in the spherical clamp hinge. Tighten the screw using a 2.5 mm hex key.

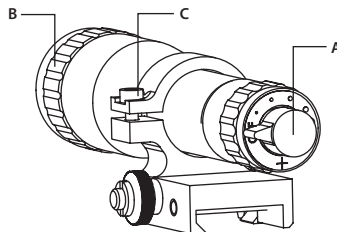

**FIGURE 3-12. IR ILLUMINATOR ADJUSTMENT**

### 3.3.3 BIT SHUT-DOWN

**NOTE:**

Shut down the Bit properly to avoid losing unsaved settings and data.

Shut-down the Bit as follows:

1. Turn off the Bit.
2. Replace the cap on the objective lens.
3. Disconnect the cable (if applicable).
4. Place the cap on the connector.
5. Remove the batteries.

**CAUTION:**

Do not store the Bit with the batteries still installed.

6. Store the Bit and all accessories in the carrying case.

# PREVENTIVE MAINTENANCE AND TROUBLESHOOTING

## 4.1 PREVENTIVE MAINTENANCE CHECKS AND SERVICES

### 4.1.1 PREVENTIVE MAINTENANCE CHECKS AND SERVICES (PMCS)

Table 4-1 Preventive Maintenance Checks and Services (PMCS) has been provided so that you can keep your equipment in good operating condition.

Perform functional tests in the order listed in Table 4-1.

Operating procedures are detailed in Chapter 3.

#### Explanation of Table Entries:

**SEQ NO. column.** Sequence numbers are for reference and appear in the order required to perform checks and services.

**LOCATION/ITEM TO CHECK/SERVICE column.** Indicates the location and the item to be checked or serviced.

**PROCEDURE column.** Details the check/ service procedure.

**NOT FULLY MISSION CAPABLE IF ... column.** Indicates what faults will prevent your equipment from operating successfully.

**TABLE 4-1. PREVENTIVE MAINTENANCE CHECKS AND SERVICES**

SEQ NO.	LOCATION ITEM TO CHECK/SERVICE	PROCEDURE	NOT FULLY MISSION CAPABLE IF ...
PRE-OPERATION CHECKS			
1	Completeness	Open storage/carrying case and inventory items by comparing them with the data specified in this manual.	Missing items.
2	Soft Carrying Case	Shake out loose dirt or foreign material. Inspect for tears, cuts, excess wear or damage.	
3	Body	Inspect for cracks or damage. Scratches and gouges are OK if operation is not affected. Inspect for missing parts. Clean as required.	Cracked or damaged. Missing parts.
4	Objective Cap	Inspect for cuts, tears and dirt. Clean as required.	Cap is torn or cut. Cap is not secured to the housing of the lens.
5	Eyecup	Inspect for cuts, tears and dirt. Inspect for torn, bent or improperly fitting eyecup. Clean as required.	Cup is torn or cut.

**TABLE 4-1. CONTINUED**

<b>SEQ NO.</b>	<b>LOCATION ITEM TO CHECK/SERVICE</b>	<b>PROCEDURE</b>	<b>NOT FULLY MISSION CAPABLE IF ...</b>
6	Battery Compartment, Cap, and, Cassette	Inspect for corrosion, moisture, and corroded or defective contacts. Inspect for cap damaged or retainer breaks. Inspect rubber gasket for damage.	Contacts are damaged or corroded. Retainer is broken. Cap or rubber gasket is damaged.
7	Lenses	Inspect for cleanliness, scratches, chips or cracks. Clean as required.	Chipped or cracked. Scratches hinder visibility.
8	Objective Focus Ring	Rotate objective focus ring to ensure it is not too tight or too loose. Range is approximately 3/4 turns.	Ring gets stuck, is too loose, or adversely affects the user's ability to properly focus the objective lens.
9	Eyepiece Focus Ring	Rotate eyepiece focus ring to ensure the ring is not too tight or too loose. Range is approximately 2 turns.	Ring gets stuck, is too loose, or adversely affects the user's ability to properly adjust the diopter.
10	Turn-pull Switch	Check for operation (without batteries).	Switch is inoperative.
11	Connector	Inspect for corrosion, moisture, and corroded or defective contacts. Inspect for cap damage or retainer breaks.	Contacts are damaged or corroded. Cap is damaged. Retainer is broken.
12	Remote Control Unit	Check for damage and missing parts. Check Velcro tape for wear.	Damaged. Missing parts.
13	Long Range IR Illuminator	Inspect the body of the IR illuminator and mount for damage and missing parts. Check IR Illuminator Power Switch for proper operation. Check IR Illuminator Battery Cap and O-ring for damage. Inspect IR Illuminator lens for cleanliness, scratches, chips or cracks. Clean as required. Check to ensure there is free rotation through the full range of travel (one turn).	Damaged. Missing parts. Switch is inoperative. O-ring is damaged or missing. Lens is chipped or cracked. Lens is sticking or too loose when turned.
14	Platform Ring	Inspect for damage, corrosion, or missing parts. Check for proper operation. Clean as required.	Damaged. Missing parts.
15	Video Cable	Inspect for damage. Inspect the cable connector for corrosion, moisture, and corroded or defective contacts. Clean as required.	Damaged.
16	Afocal Doubler	Inspect the Afocal Doubler lens optical surfaces for cleanliness, scratches, chips or cracks. Clean as required. Inspect the front cap for cuts, tears and dirt. Inspect the rear cap for ease of installation and dirt. Clean as required. Check ease of attaching and removal of the lens. Clean as required.	Chipped or cracked. Scratches hinder vision through the equipment. The front cap is torn or cut, or is not secured to the housing of the lens. The rear cap is damaged. Damaged.
<b>OPERATIONAL CHECKS</b>			
17	Turn-pull Switch	Install the batteries. Remove the objective lens cap. Point the equipment at an object. Turn the equipment on. Look for an image on the display. Look for a flashing battery icon in the eyepiece viewing area.	No image. Battery icon is flashing (indicates a low battery).
18	Control Board	Ensure the Bit is responsive to control buttons.	Unresponsive buttons.
19	Remote Control	Turn the equipment to standby. Point the equipment at an object. Press the remote control button. Look for an image on the display. Press the button again. Turn off the equipment.	No image.
20	Video Cable	Connect an external monitor to the Bit. Point the equipment on an object. Turn the equipment on. Look for an image on the monitor. Turn off the Bit. Disconnect the monitor.	No image.
21	Long Range IR Illuminator	Insert the battery. Mount the IR illuminator onto the Bit. Turn the IR illuminator on. Direct the radiated beam at a wall from a distance of about 5 m. Look through the Bit. A square of light should appear on the wall.	No light appears on the wall.
<b>POST-CHECK PROCEDURES</b>			
Turn off the equipment.			
Replace the objective lens cap.			
Remove the batteries.			
Return the equipment and all accessories to the carrying case.			

## 4.2 OPERATOR TROUBLESHOOTING

The purpose of troubleshooting is to identify the most frequent equipment malfunctions, probable causes, and corrective actions required.

Table 4-2 lists the common malfunctions that may be found during the operation or maintenance of the Bit. Perform the tests/inspections and corrective actions in the order listed.

**This table does not list all of the malfunctions that may occur with your device, or all of the tests and corrective actions that may be necessary.** If you experience an equipment malfunction that is not listed, or is not fixed by the corrective actions listed in the table, please contact Armasight's Customer Service center.

**TABLE 4-2. OPERATOR TROUBLESHOOTING**

MALFUNCTION	PROBABLE CAUSE/ TEST/INSPECTION	CORRECTIVE ACTION
The Bit fails to activate.	Batteries are missing or improperly installed.	Insert batteries or install correctly.
	Batteries are dead.	Replace the batteries.
	Batteries, surfaces or contacts are dirty or corroded.	Clean the contact surfaces with a pencil eraser and/or alcohol and cotton swabs.
	Remote control unit is damaged.	Please contact Customer Support.
	Remote control battery is dead.	Replace the battery as per Part 4.3.4.
	The equipment is damaged.	Please contact Customer Support.
The Bit is not responsive to control buttons.	The equipment is damaged.	Please contact Customer Support.
Remote control does not work.	Battery is missing or improperly installed.	Insert battery or install correctly.
	Battery is dead.	Replace the battery.
	Battery surfaces or contacts are dirty or corroded.	Clean the contact surfaces with a pencil eraser and/or alcohol and cotton swabs.
	Remote control unit is damaged.	Please contact Customer Support.
Poor image quality.	Check objective lens and eyepiece focus.	Refocus.
	Check for fogging or dirt on objective lens and eyepiece.	Clean the lenses as detailed in Part 4.3.2.
	The equipment is damaged.	Please contact Customer Support.
No image	Video cable is damaged.	Replace the video cable with a new one. Please contact Customer Support.
	The equipment is damaged.	Please contact Customer Support.
Hindered rotation of the battery cap.	Dirty cap thread.	Clean the thread.
	Damaged cap thread.	Replace the cap with a new one. Please contact Customer Support.
Light is visible around eyecup.	Check eyecup resilience.	If the eyecup is defective, please contact Customer Support.

## 4.3 MAINTENANCE

### 4.3.1 GENERAL

The Bit operator maintenance consists of operational tests, inspections for unit serviceability, cleaning and mounting procedures, corrective actions (troubleshooting and replacement of a limited number of parts). Maintenance instructions covered elsewhere in this manual (PMCS, troubleshooting, etc.) are not repeated in this section.

**CAUTION:**

The Bit is a precision electro-optical instrument and must be handled carefully at all times to prevent damage.

**CAUTION:**

DO NOT dismantle the equipment.

### 4.3.2 CLEANING PROCEDURES

Clean the Bit and optional items as follows:

1. Gently brush off any dirt from the equipment using only a clean, soft cloth.
2. Moisten the cloth with fresh water and gently wipe the external surfaces (**except** for optical surfaces).
3. Dry any wet surfaces (**except** for optical surfaces) with another clean, dry soft cloth.
4. Using a lens brush, carefully remove all loose dirt from optical surfaces (objective lens and eyepiece).
5. Slightly dampen a cotton swab with ethanol and lightly and slowly wipe optical surfaces. Clean optical surfaces using circular movements, starting from the center and moving out towards the edge, not touching the lens holder and changing the cotton swab after each circular stroke. Repeat until the optical surface is clean.
6. Clean the battery contact surfaces and contact springs with a pencil eraser and/or alcohol and cotton swabs.

**CAUTION:**

Thoroughly dry each item before replacing into the storage/carrying case.

### 4.3.4 BATTERY REMOVAL AND REPLACEMENT

Refer to Part 3.1.1 for battery installation procedures.

Refer to Part 3.1.6 for IR illuminator battery installation procedure.

Replace the remote control battery as follows:

1. Using a screwdriver, unscrew the four screws (A, Figure 4-1) that secure the cover to the bottom of the unit. Remove the cover.
2. Replace the battery with new one (CR2032, 3V). Install the battery, aligning it polarity markings (+/-) with those embossed on the compartment.
3. Replace the cover and tighten the screws (A).

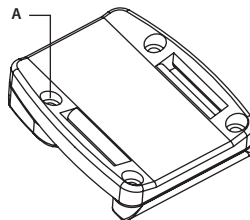

**FIGURE 4-1. ADVANCED WIRELESS REMOTE CONTROL BATTERY INSTALLATION**

## 4.4 RETURN INSTRUCTIONS

For service, repair or replacement, please email: [service@armasight.com](mailto:service@armasight.com).

To assist the Service Representative (SR) with determining if the item is repairable, please provide the following information:

1. Serial Number of the defective item (engraved on bottom of the equipment).
2. Thorough description of the malfunction, defect or damage.
3. An explanation of how the malfunction, defect or damage occurred, if known.

If the SR determines that the item is under warranty or should be returned for repair, a Return Material Authorization number (RMA#) will be provided.

When returning the Bit for service or repair, the following procedures should be followed to prevent any additional damage:

1. Make sure the Bit is free of all contaminants such as dirt or any other foreign material.
2. Remove the batteries.
3. Place the cap over the objective lens.
4. Place the Bit and accessories in the carrying case.

Place the Bit and a copy of the test report or detailed description of the failure in a suitable packing/shipping container. Mark the package with the RMA#. Ship the fastest, traceable, prepaid means to:

Armasight Inc.  
815 Dubuque Avenue  
South San Francisco, CA 94080  
USA

## A. LIST OF SPARE PARTS

The parts authorized by this list of spare parts are required for operator maintenance. The list includes parts that must be removed before replacing authorized parts.

The PART NO. column indicates the primary number used by the manufacturer, which controls the design and characteristics of the item in terms of its engineering drawings, specifications, standards, and inspection requirement, to identify an item.

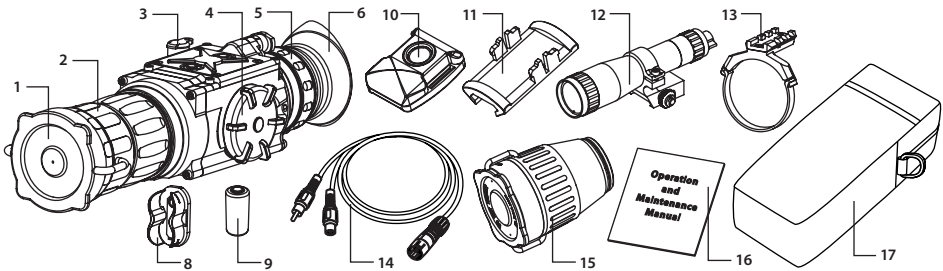

**FIGURE 2-3. BIT STANDARD COMPONENT**

**TABLE A-1. BIT SPARE PARTS LIST**

ITEM NO.	DESCRIPTION	PART NO.
1	Objective Lens Cap	ABPSOLC
2	Objective Lens Assembly	ABPSOLA
3	Connector Cap	ABCCP
4	Battery Cap	ABPSBC
5	Eyepiece Assembly	ABPSEPA
6	Eyecup	ABPSEC
7	Side Picatinny/Weaver Rail (not shown)	ABPSPRL
8	Battery Cassette	ABBTCS
9	CR 123A Lithium Battery	ALT
10	Advanced Wireless Remote Control	ANVR000001
11	Picatinny Adapter for Advanced Wireless Remote Control	ANRA000002
12	IR850W Detachable Wide Angle Adjustable X-Long-Range Infrared Illuminator	IAIR850IR000002
13	Platform Ring	ATAM000003
14	Video Cable	ATCA000004



**TABLE A-1. CONTINUED**

ITEM NO.	DESCRIPTION	PART NO.
15	Afocal Doubler	ANAF18X039
16	Operation and Maintenance Manual	ABOMM
17	Carrying Case	ABCRC5

## B. PRODUCT WARRANTY REGISTRATION CARD

In order to validate the warranty on your product, Armasight must receive a completed Product Warranty Registration Card for each unit, or the user must complete warranty registration on our website ([www.armsight.com](http://www.armsight.com)). Please complete the included form and immediately mail it to our Service Center:

Armasight Inc.  
 815 Dubuque Avenue  
 South San Francisco, CA 94080  
 USA

### ARMASIGHT PRODUCT WARRANTY REGISTRATION CARD

#### PRODUCT INFORMATION

Product Name \_\_\_\_\_ Purchased From \_\_\_\_\_

Purchase Date \_\_\_\_\_ Product Serial # \_\_\_\_\_

#### CUSTOMER INFORMATION

Name \_\_\_\_\_

Address \_\_\_\_\_

City \_\_\_\_\_ Country \_\_\_\_\_ Zip \_\_\_\_\_

Day Phone # \_\_\_\_\_ Home Phone # \_\_\_\_\_

E-mail address \_\_\_\_\_

.....  
 Customer Signature Required







Armasight Inc.

815 Dubuque Avenue  
South San Francisco  
CA 94080, USA

Phone: (888)959-2259

Fax: (888)959-2260

Intl Phone/Fax: (650)492-7755

[info@armasight.com](mailto:info@armasight.com)

**CAUTION:**

**This product contains natural rubber latex which may cause allergic reactions!** The FDA has reported an increase in the number of deaths that are associated with an apparent sensitivity to natural latex proteins. If you are allergic to latex, it is a good idea to learn which products contain it and strictly avoid exposure to those products.

[www.armasight.com](http://www.armasight.com)