

LOW NO_x TURBOPOWER® • PACKAGED WATER HEATER
NICKELSHIELD® NICKEL-PLATED STORAGE TANK
TANK SERIES 750 GALLONS VERTICAL

MODEL NUMBER	Recovery gph ①		INPUT Btu/h	Min. Inlet Flow Gas Pressure " W.C. ③	SCAQMD Energy Model No.		Dimensions (inches)				Blower Motor		Shipping Weight lbs
	40° - 120°F	40° - 140°F					A	B	C	J ②	HP	Amps	
500 N 750A-TPL	500	400	399,000	4.5	4TPL	399 MBtu/h	28	5	3/4	16	1/3	8	2660

① Recoveries based on 83% thermal efficiency. ASHRAE 90.1 compliant for efficiency and standby loss.

② "J" dimension is for the burner housing only – gas train may exceed this dimension.

③ Standard gas train.

* The information presented is for natural gas 0.6 S.G.

Dimensions are in inches unless otherwise specified.

For standard and optional equipment, see form #PV6540.

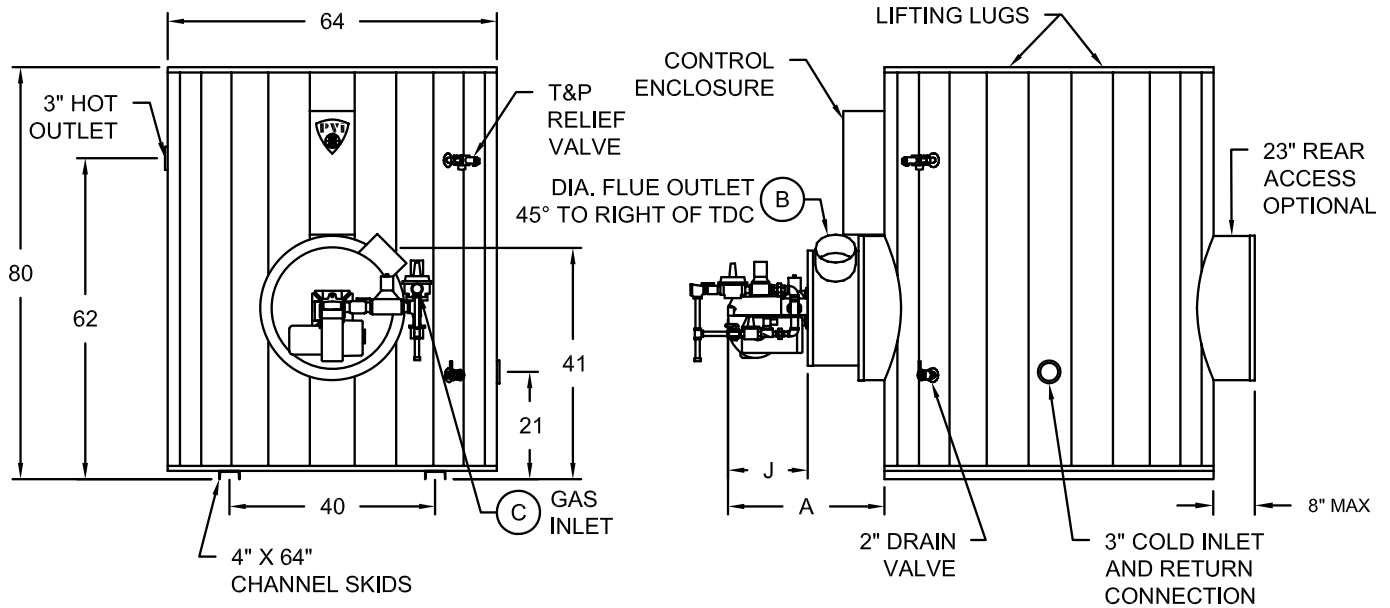

STANDARD GAS PRESSURE REQUIREMENTS:

SEE TABLE FOR MINIMUM PRESSURE BY MODEL NUMBER.
 MAXIMUM STATIC INLET GAS PRESSURE IS 14" W.C.
 FOR GAS PRESSURES OUTSIDE OF THIS RANGE,
 CONTACT YOUR PVI REPRESENTATIVE.

STANDARD ELECTRICAL REQUIREMENTS:

CONTROL VOLTAGE: 120V, 1Ø, 60 HZ., 2 AMPS.
MOTOR VOLTAGE: 1/3 HP ARE 120V, 1Ø, 60 HZ.
 208V, 230V AND 460V MOTORS ARE AVAILABLE BUT WILL
 REQUIRE A SEPARATE 120V/2 amps CONTROL CIRCUIT OR AN
 OPTIONAL CONTROL CIRCUIT TRANSFORMER.

VENTING REQUIREMENTS:

-.02" TO -.06" W.C. (NEGATIVE PRESSURE).
 TYPE B VENTING.
**ENTIRE VENT SYSTEM SHOULD NEVER BE SIZED BASED UPON
 THE VENT CONNECTION DIAMETER EXCLUSIVELY. CHECK
 NATIONAL FUEL GAS CODE UNDER "FAN ASSISTED."**

PVI RESERVES THE RIGHT TO CHANGE THE DESIGN AND SPECIFICATION WITHOUT NOTICE.



PVI INDUSTRIES, LLC
 FORT WORTH, TEXAS 76111
 (800) 784-8326 • www.pvi.com

Product is patented in the U.S., Canada, and Mexico.

