



Electronic & Navigation



Only the best will do !

- For ultimate quality, Plastimo selects the best components in order to ensure that your compass is a highly dependable instrument which will provide years of reliable service.
- A sapphire equips every compass: its hardness is a warranty for the long life and precision of your compass.
- All plastimo compasses feature an anti-vibration system, which ensures a minimal contact between the pivot and the sapphire cup ; the latest-born “Vibration absorber” device damps spinning caused by high-speed pounding and vibration.
- A compass is a meticulously engineered instrument: all the “precious” components are produced by Swiss clock-makers, worldwide famous for their legendary precision.
- The soft Viton® diaphragm or the semi-soft ultra-sound welded diaphragm is fully waterproof and has extreme expansion and retraction capacity: it compensates the fluctuations in fluid volume caused by the differences in temperature and atmospheric pressure.
- All plastic components -and more specifically the material used for the dome- are carefully selected to withstand shocks, UV-rays and harsh marine environment.
- The crystal transparency of the dome and the exceptional magnifying index of the fluid contribute to the perfect legibility of the card.

Viton® is a registered trade mark of Dupont de Nemours.



How to select your compass

➤ What type of boat do you own?

You should know that the main differences between a sailboat and a powerboat (in terms of compass construction) are the heeling angle and the resistance to vibration and shocks. These technical elements are of course integrated in the engineering of our compasses..

➤ What is your navigation programme ?

Day sailing, cruising, passage making, racing... you will select a compass with or without lighting, with or without compensation, with the right card balanced for the geographical card where you are going to sail, with a plain or tactical card.

➤ Which size of compass ?

If the compass is designed to be read from a distance, you will need a larger compass. Generally speaking and as a benchmark indication, you should select a card apparent diameter between 70 and 90 mm, for a 5 to 9 m boat (17-30 ft).

➤ Which type of mounting ?

Flushmounted on a horizontal, vertical or inclined bulkhead, on a binnacle or minibinnacle, on a bracket, in a take-away or mast-mounted version... you must choose a compass which remains easily readable (shape of card) at all times. The Plastimo range of compasses covers all mounting options and all our models are designed for minimum drilling and screwing.



Flat card

A flat card is read on the back edge, where the lubberline is located. The fluid magnifies the numerals which become easier to read. In addition, the flat card provides a global view of the card and its North point in relation to the boat's direction.



Conical or cylindrical card

Reading from the front and the top of the card. In addition to front reading, this type of card usually features numerals and cardinal points on the top part of the card, thus providing two reading possibilities. This card is particularly suitable when steering or piloting is done sitting or standing.



Offshore[®] 75



OFFSHORE 75	
Boat size	Powerboats of 5 to 8 metres (17 to 26 ft).
Compass card	Conical card graduated every 5° apparent Ø 70 mm. Heading numerals every 30°.
Mounting	Flushmount : on a horizontal, vertical or inclined surface.
	Mini-binnacle : mounted on a horizontal surface thanks to a clip-plate (supplied) ; compass is removable.
	With a bracket : mounted on a horizontal or inclined surface. Compass is removable thanks to clip-plate.
Resistance to vibrations and hull pounding	Magnetic cell equipped with the unique "Vibration Absorber" system.
Lubber line	1 lubber line.
Compensation	Optional (on mini-binnacle and bracket-mount models)
Lighting	Included on all Offshore models (1 bulb 12 Vdc). No lighting on Offshore Basic.
Supplied with	Clip-plate, screws, drilling template.
Approval/homologation	ISO 613 compliant.

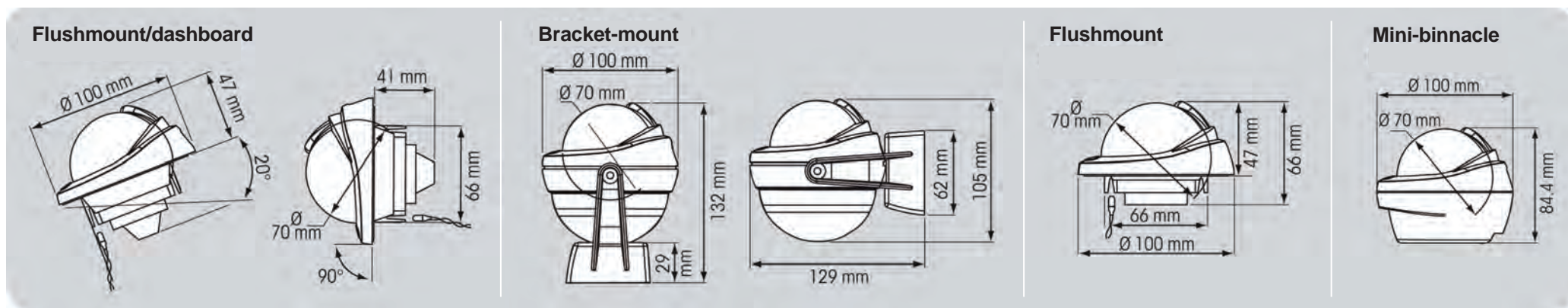

Offshore® 95



OFFSHORE 95	
Boat size	Powerboats from 6 to 10 metres (19 to 33 ft).
Compass card	Conical or flat card graduated every 5°, apparent Ø 81mm. Heading numerals every 30°.
Mounting	<ul style="list-style-type: none"> • Flushmount, on a horizontal surface. • With a bracket : mounted on a horizontal or inclined surface. Compass is removable thanks to clip-plate.
Resistance to vibrations and hull pounding	Magnetic cell equipped with the unique "Vibration Absorber" system.
Lubber line	1 lubber line.
Compensation	Supplied as standard.
Lighting	1 bulb 12 V, included.
Supplied with	Clip-plate, screws, drilling template.
Homologation	ISO 613 compliant.

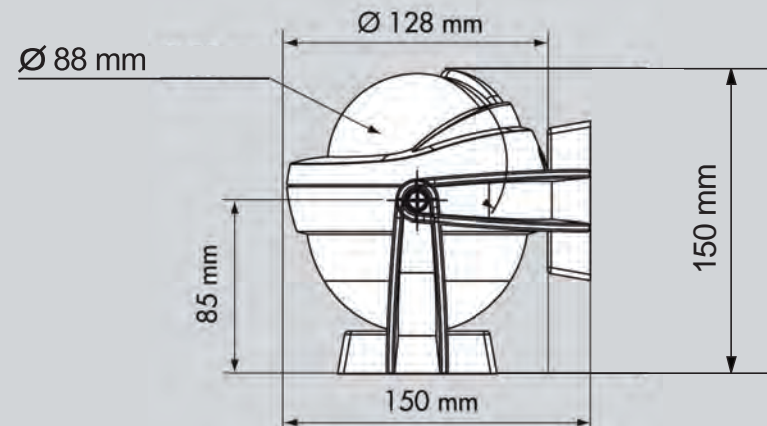
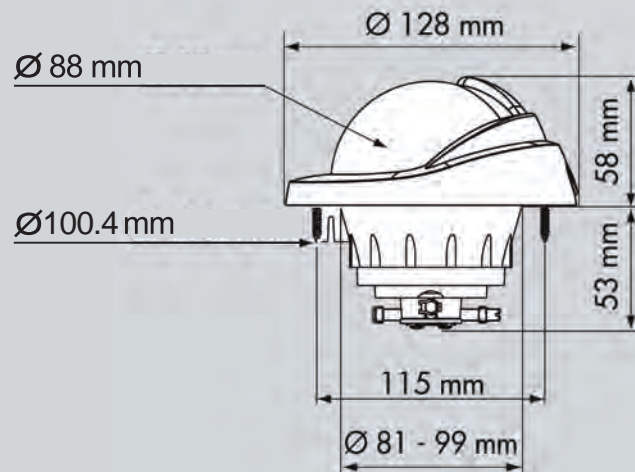

Offshore[®] 115



OFFSHORE 115	
Boat size	Powerboats from 8 to 12 metres (26 to 40 ft).
Compass card	Conical or flat card graduated every 5°, apparent Ø 101mm. Heading numerals every 30°.
Hood	Articulated protective hood : built-in sliding cover, composed of 3 telescopic parts, with cushioned closing.
Mounting	<ul style="list-style-type: none"> • Flushmount, on a horizontal surface. • Binnacle available as option.
Resistance to vibrations and hull pounding	Magnetic cell equipped with the unique "Vibration Absorber" system.
Lubber line	1 lubber line.
Compensation	Supplied as standard.
Lighting	1 bulb 12 V, included.
Supplied with	Screws, drilling template.
Approval/homologation	SOLAS-MED 96/98.

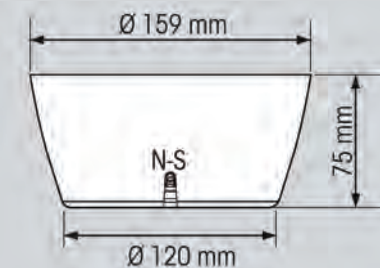
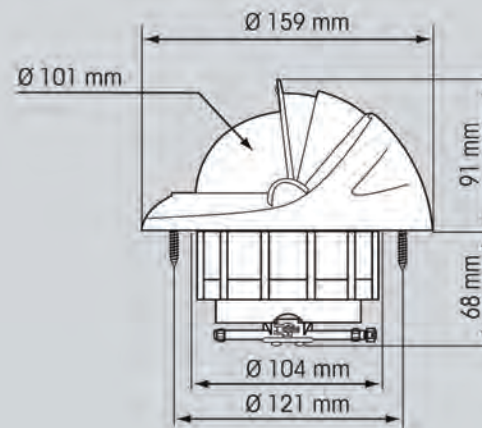
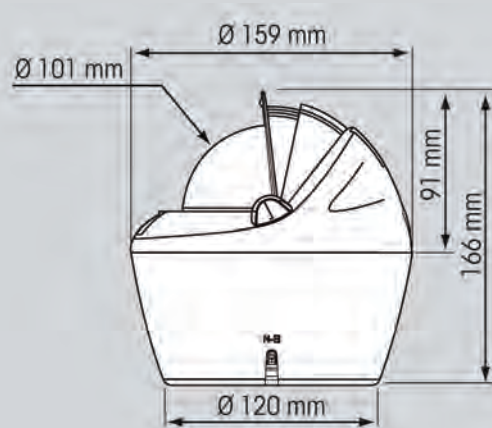

Offshore® 105 & 135



	OFFSHORE 105	OFFSHORE 135
Boat size	Powerboats of 5 to 9 m (17 to 30 ft).	Powerboats of 10 m and above (33 ft +).
Compass card	Graduated every 5°, apparent Ø 91 mm. Heading numerals every 30°.	Graduated every 5°, apparent Ø 130 mm. Heading numerals every 30°.
Hood/sunshade	Articulated protective hood : built-in sliding cover, composed of 3 telescopic parts.	Articulated protective hood : built-in sliding cover, composed of 3 telescopic parts.
Mounting	Comes as standard in a flushmount version. Can be bracket-mounted with the addition of optional bracket.	Comes as standard in a flushmount version. Can be bracket-mounted with the addition of optional bracket.
Resistance to vibrations and hull pounding	Magnetic cell mounted on shock absorbers.	Magnetic cell mounted on shock absorbers.
Lubber line	1 lubber line.	1 lubber line.
Compensation	Supplied as standard.	Supplied as standard.
Lighting	<ul style="list-style-type: none"> • On flat card: 2 bulbs, 12V. • On conical card: 1 bulb, 12V. 	<ul style="list-style-type: none"> • On flat card: 2 bulbs, 12V. • On conical card: 1 bulb, 12V.
Approval/homologation	ISO 613 compliant.	SOLAS-MED 96/98

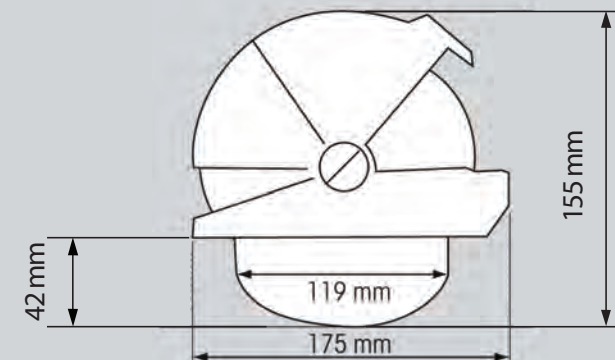
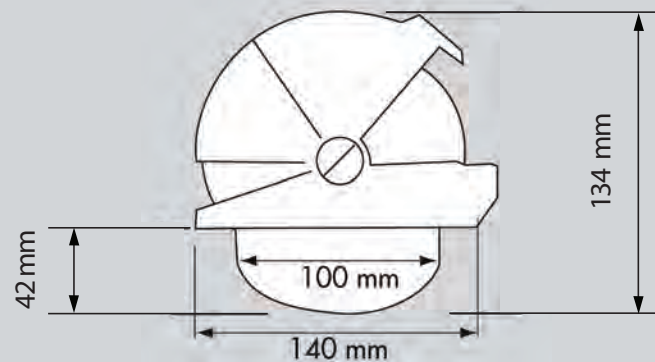

Horizon[®] 135



HORIZON 135	
Boat	Yachts -sailing and power- over 9 m (30').
Card	Flat card graduated every 5°. Apparent Ø 130 mm.
Mounting	Flushmount on horizontal surface or pedestal-mount (with optional binnacle).
Lubber line	3 lubber lines at 45°.
Compensation	Supplied as standard. Tunnel rods allow easy access to compensators through the binnacle.
Lighting	12 V, supplied as standard.
Supplied with	Sunshield and protective cover, drilling template.
Homologation	ISO 613 compliant

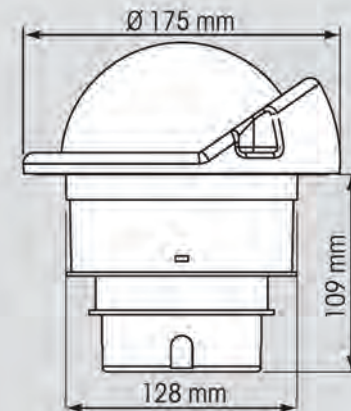
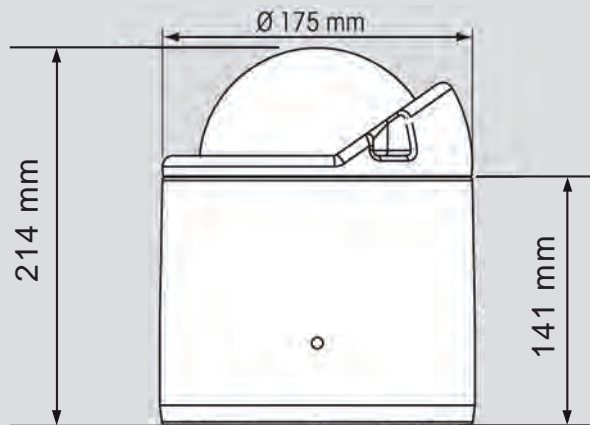

Combo C.56

*All-in-one navigator : combines a high resolution VGA **GPS chart plotter** with powerful dual frequency **sonar**.*

FEATURES

- 5.6" VGA (640 x 480) screen bonded,
- Ultra-bright daylight viewable display.
- 50/200 kHz dual frequency sonar with powerful 600 W RMS power output to display targets up to 600 m (2000 ft) depending on the connected transom.
- Digital speed and temperature data.
- "SnapShot" function : save your favourite sonar or chart images in the onboard memory (128 Mb) or removable SD-HC card, enabling transfer to your PC for viewing and printing.
- CMAP MAX on SD card format.
- NMEA0183 interface : 2 inputs and 2 outputs.
- NMEA2000 interface : to repeat or process data from other sources such as engines, intelligent transducers and navigation instruments.
- AIS compatible.
- Waterproof to IPX7



GPS T.56

High resolution VGA GPS chart plotter, with both NMEA0183 and 2000 connections. This makes the T.56 a complete multi-function navigation repeater of all external data on board compatible external devices

FEATURES

- 5.6" VGA (640x480) screen bonded, ultra-bright daylight viewable display.
- Digital speed and temperature data
- SnapShot" function : save your favourite chart image in the onboard memory (128 Mb) or removable SD HC card, enabling transfer to your PC for viewing and printing.
- CMAP MAX on SD card format.
- NMEA2000 interface : to repeat or process data from other sources such as engines, intelligent transducers and navigation instruments.
- NMEA0183 interface: 2 inputs and 2 outputs
- AIS compatible.
- Waterproof to IPX7



GPS T.50

A compact chart plotter with bright and sharp QVGA display. The T.50 combines a fully featured navigation program with a simple intuitive operating system that allows fast and easy access to frequently used functions (GOTO, favourite screens...).

FEATURES

- 5" LCD unit, QVGA bright and sharp (320 x 240 resolution), daylight viewable display.
- "SnapShot" function : save your favourite chart image in the onboard memory (128 Mb) or removable SD HC card, enabling transfer to your PC for viewing and printing.
- CMAP MAX on SD card.
- NMEA 0183 compatible : 2 inputs and 2 outputs.
- AIS compatible when connected to an AdvanSea receiver or an NMEA0183 compatible instrument.
- Waterproof to IPX7.



GPS & Combo

MAIN FEATURES	C.56	T.56	T.50
LCD display type	LCD - TFT - LED backlighting		
LCD diagonal	142 mm (5.6")	127 mm (5")	
Screen Resolution	640 x 480 (VGA)	320 x 240 (QVGA)	
Operating voltage	10 - 34 V		
Memory	128 Mb		
Embedded chart	World		
Cartography	CMAP NT MAX (SD-Card support)		
GPS antenna type	Integrated, 16 channels / optional: BNC - socket external antenna		
Waypoints	9999		
Routes	250 routes with 500 waypoints per route		
Track logs	Max.10		
Chart display	North / Track / Course		
Plotting scale	0.005 NM / 500NM		
Data interfaces	NMEA0183 (2 in & 2 out); NMEA2000		NMEA0183 (2 in & 2 out)
Fuel management	NMEA2000 compatible engines		No
Sonar	Yes (50/200khz)	No	
Max. Depth	600 metres	-	
Output power	600 W RMS	No	
Environmental rating	Waterproof to IPX7		

AIS RX-110

Receiver

The RX-110 outputs the received AIS data transmitted by vessels with class A and B transponders on the VHF network.

NMEA 0183
USB
NMEA 2000

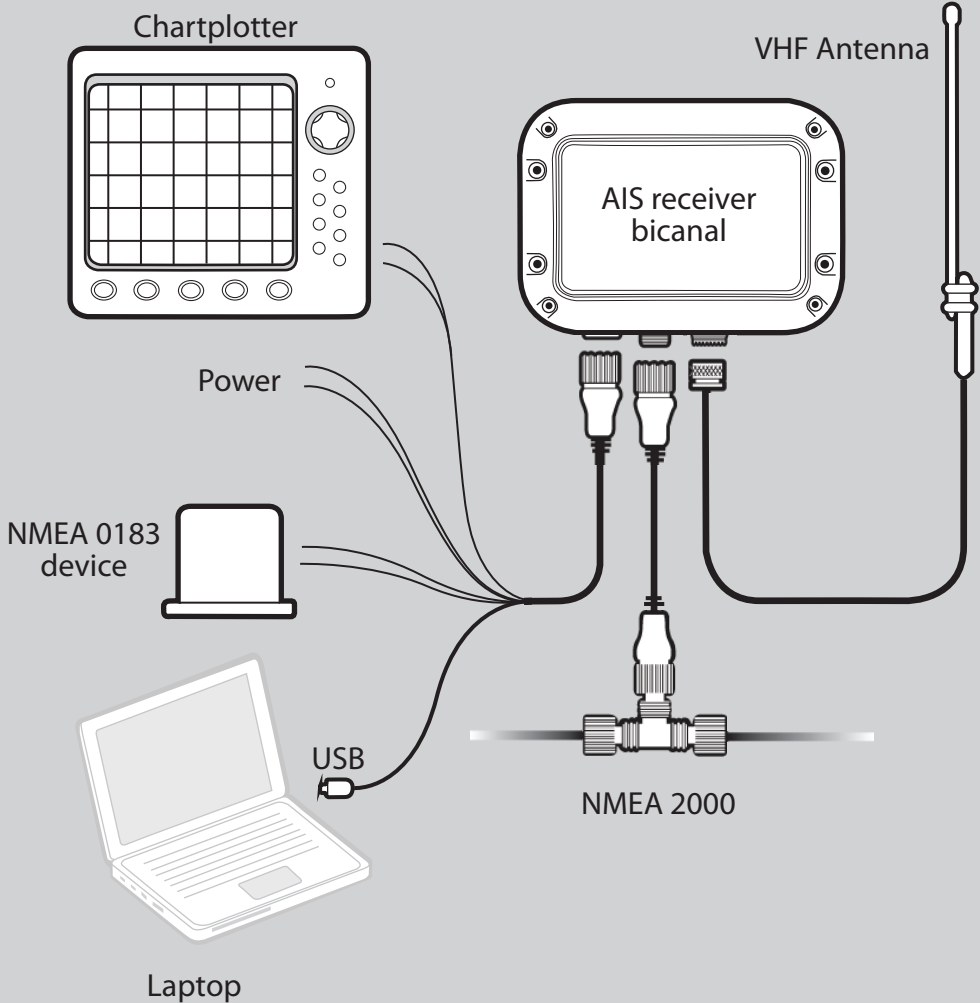

AIS TR-210

Transceiver

See and be seen.

This Class-B AIS transceiver module enables both the transmission and reception of AIS data from your boat.

Your vessel identification data is programmed into the TR-210 using the software and cable included with the transceiver. The TR-210 AIS transceiver output connects to your GPS/Plotter via the NMEA 0183 or NMEA 2000 (depending on instrument compatibility) interface and to your PC through the USB connector.

The TR 210 has an internal GPS antenna providing vessel position data to the AIS transmitter.

An external GPS antenna can be connected if necessary

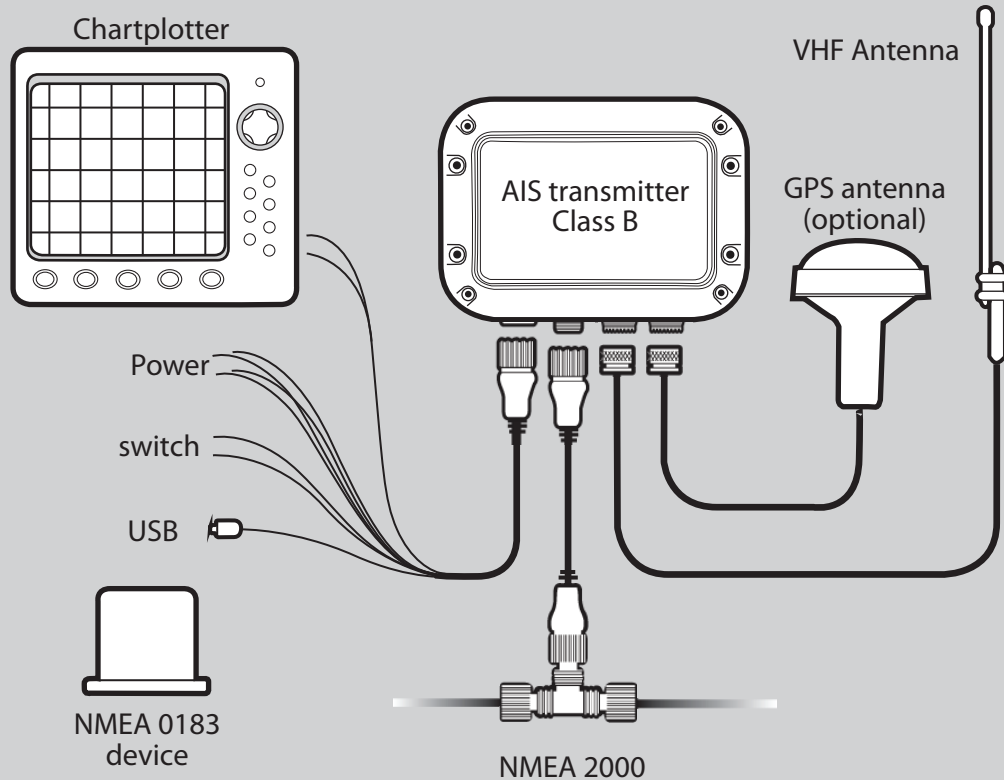

NMEA 0183
USB
NMEA 2000



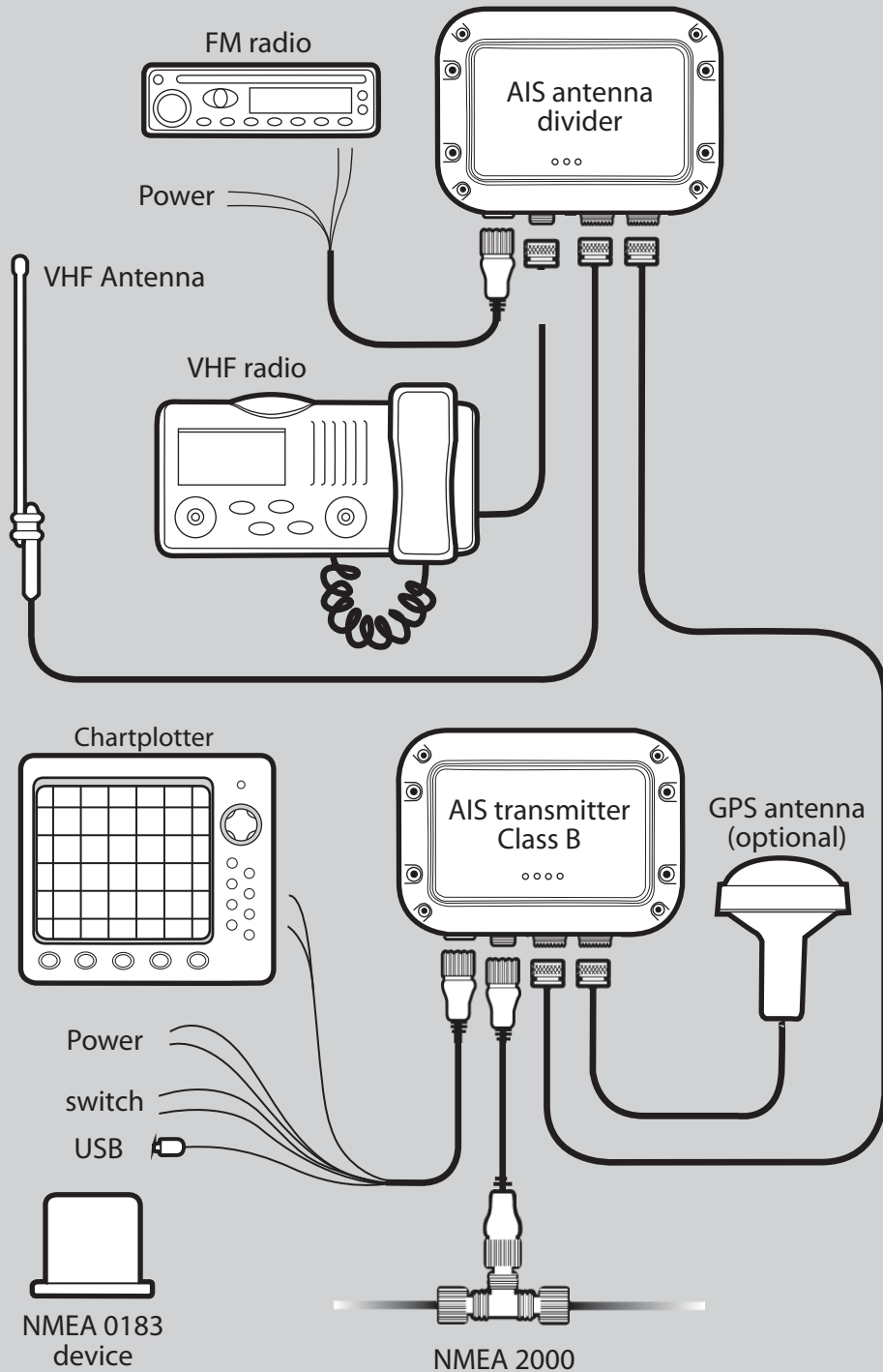

AIS SPLIT-110

VHF Splitter

Enables the simultaneous use of the vessel's installed marine VHF radio and an AIS receiver via a single VHF antenna.



Specifications

AIS RX-110

AIS TR-210

AIS SPLIT-110

Dimensions	140 x 100 x 42 mm (L x W x H)	140 x 100 x 42 mm (L x W x H)	140 x 100 x 43 mm (L x W x H)
Weight	250 g	250 g	250 g
Power	12 to 24 VDC - Power consumption : 200 mA@12VDC	12 to 24 VDC - Power consumption : 170 mA@12VDC	12 to 24 VDC - Power consumption : < 150 mA@12VDC
Electrical interfaces	NMEA 0183, 38400 Baud (output), NMEA 0183 4800 Baud (input) - USB - NMEA 2000®	NMEA 0183, 38400 Baud (output), NMEA 0183 4800 Baud (input) - USB - NMEA 2000®	VHF antenna output (SO239 connector) - VHF radio input (SO239 connector) - AIS input (BNC connector)
Supplied with	Power, NMEA 0183 & USB cable - User manual - Quick start guide - Warranty card - CD & Fixing screws.	Power, NMEA 0183 & USB cable - User manual - Quick start guide - Warranty card - CD & Fixing screws.	Power cable - VHF radio interface cable - AIS interface cable - User manual - Quick start guide - Warranty card - CD & Fixing screws.
User interface	2 LED indicators for power and AIS message reception	4 LED indicators for power, transmit timeout, Error and Silent mode	3 LED indicators for power, VHF and AIS transmission
Operating temperature	-25 °C to +55 °C	-25 °C to +55 °C	-10 °C to +55 °C
Waterproofness	IPX7.	IPX7.	IPX7.

Echofish 300

Available with floating sensor or handheld sensor

Both versions are supplied as standard with fixing bracket.

- Separate transducer with backlit graphic screen **42 x 48 mm FSTN**, **128 x 64 pixels**.
- 200 kHz sensor with 45° beam.
- Ultra-light splashproof (IPX4) case : 200 g, ncluding batteries.



Echofish 400

Available with floating sensor only.

Supplied as standard with floating sensor, 8-m cable and fixing bracket.
The same features as top-end models, with a high resolution display.

- Separate transducer with backlit 47 x 47 mm display. Graphic LCD 16-level greyscale display, 160 x 160 pixels.
- 200 kHz / 83 kHz dual frequency fishfinder with 20°/60° beams.
- Ultra-light splashproof (IPX4) case : 187 g, including batteries.



Echofish 300

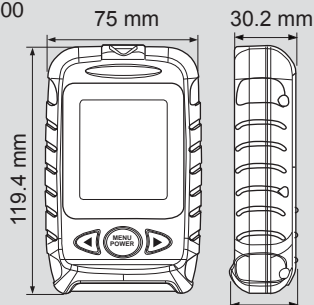

Echofish 400

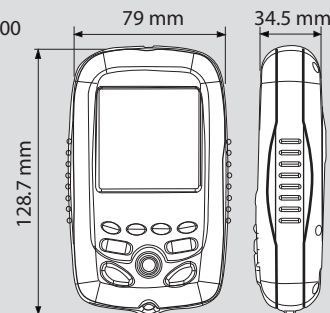

Handheld sensor version



On boat



On the seashore

Floating sensor version

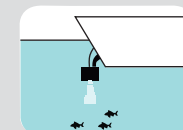

Fixed to the boat hull

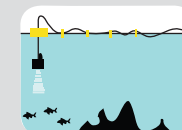

Floating

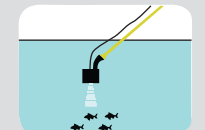

On a pole

Echofish 600

- Large FSTN LCD 4.5" (115 mm) display.
- Resolution 240 x 128 pixels.
- 4-level grayscale.
- Rugged and waterproof to IPX7 housing.
- 6-m cable
- Supplied as standard with 200 kHz mono-frequency sensor.



Echofish 820

- Large 4.3" (110 mm) TFT LCD display, daylight viewable.
- Resolution 480 x 272 pixels.
- Colour display (65536 colours).
- Rugged and waterproof to IPX7 housing.
- True 600 m (2100 feet) capability with 4000 W peak to peak output power.
- 6-m cable
- Supplied as standard with 200/50 kHz dual-frequency sensor.

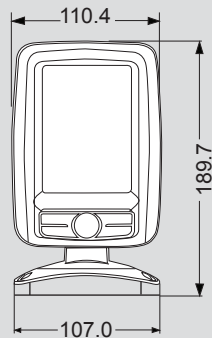

Unit : mm

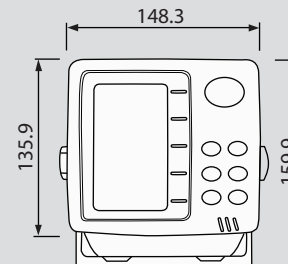
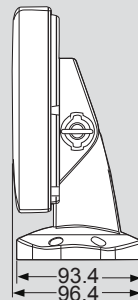

Unit : mm

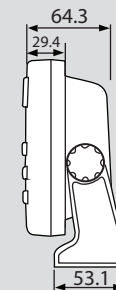

Specifications



	Echofish 300	Echofish 400	Echofish 600	Echofish 820
Model	Handheld	Handheld	Fixed	Fixed
LCD diagonal	63.7 mm	66.4 mm	115 mm	110 mm
Resolution	128 x 64 pixels	160 x 160 pixels	240 x 128 pixels	480 x 272 pixels
Display	4-level grayscale	16-level grayscale	4-level grayscale	65536 colours
Power	4 AAA batteries	4 AAA batteries	12 V	12 V
Type of frequency	Mono-frequency	Mono-frequency	Mono-frequency	Dual-frequency
Sonar frequency	200 kHz	200/83 kHz	200 kHz	200/50 kHz
Beams	45°	20°/60°	20°	12°/35°
Surface explored at 20 m	171 m ²	31 m ² /326 m ²	31 m ²	11 m ² /100 m ²
Maximum depth	73 m	73 m	230 m	600 m
Simulation mode	Yes	Yes	Yes	Yes
Weight	200 g with batteries	187 g with batteries	460 g	560 g
Type of sensor	Floating or handheld	Floating	Transom	Transom



ROY'S MARITIME

Floor 6, 20/16 Nguyen Truong To St
Ward 12, District 4, Ho Chi Minh City
Mail: giang.doan@roysmaritime.com

www.roysmaritime.com

