

P series Aluminum-Rail Type Temperature Controller Manual (Aluminum-Rail installation)

Note:
 1. Please make sure if the terminals are wired correctly and if the input power conforms with the specifications before power supply is connected.
 2. If power supply is connected, do not touch the power terminals to prevent electric shock.
 3. Do not mount the controller in a place where is likely to be interfered by radio frequency or where is corrosive of humid.
 4. Please select spade terminal cables to do the wiring.
 5. If the cable of the thermocouple needs to be extended, please use extension wire of the same type.
 6. The conducting wire of platinum resistance (Pt100) should be as shorter as possible, or of low impedance.
 7. To avoid interference, signal cable and power lines should be kept away from load power conducting wire.
 8. In case hazard should occur if the controller breaks down, breakers or fuses should be fitted

Model No. Explanation

Pm0	-	1	1	0	2	-	A
Model	Control output	Alarm	Input type	Comm./Re-transmitting	Power		
Pm0 STD	0 Null	1 1set(O.C)	0 TC/RTD	0 Null	A 90~240V		
Pm1 program control	1 RELAY	A HBA(50A)	-	-	D 24~36V		
	2 24V(SSR)	D HBA(100A)	3 4~20mA	2 RS-485	(AC or DC)		
	3 4~20mA		4 0~5V	3 4~20mA			
	4 0~5V		5 1~5V	4 0~5V			
	5 1~5V		6 0~10V	5 1~5V			
	6 0~10V		7 2~10V	6 0~10V			
	7 2~10V			7 2~10V			

Specifications

Dimension (WXLXH)mm	22.5X75X101
Power supply	AC90~240V(60/50Hz),DC24V(optional)
Power consumption (Approx.)	5 VA
Net Weight (Approx.)	80g
Storage/Operating ambient	0~65°C/0~50°C, 20~90%RH
Data backup memory	EEPROM, 10年
Accuracy	0.3%FS
Display height (mm) PV (red) / SV (green)	PV (red) 8 SV (green) 8
Alarm output	NPN O.C 100mA Max, endure 32VDC
Control output	Relay contacts: 5A, 250VAC Logic voltage (to drive SSR): ON=24V (20mA Max) Analog current: 4~20mA (Input impedance 600Ω Max.) Analog voltage: 0~10V (Input impedance 1KΩ Min.)
Input type	Thermocouple, RTD, analog voltage/current. Refer to input type list

Panel Explanation

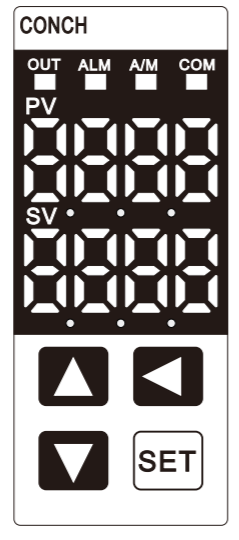

OUT(G): Indicator of output
 ALM®: Indicator of alarm output
 A/M(Y): Flash=Perform AUTO-TUNING
 Light on continuously=manual output mode
 COM(Y): Indicator of comm.
 PV (R): Present temp. value
 SV (G): Set value

- SET** : Set key, starts or ends the parameter setting
- ◀** : Left key, change the parameter set value
- ▲** : Up key, the parameter value increases 1
- ▼** : Down key, the parameter value decreases 1

List of input type

Input type	Code	Detecting range	Code	Detecting range	Code	Detecting range	
Thermocouple	K	K1	0.0~200.0°C/0.0~392.0°F	K2	0.0~400.0°C/0.0~752.0°F	K3	0~600°C/0~1112°F
		K4	0~800°C/0~1472°F	K5	0~1000°C/0~1832°F	K6	0~1200°C/0~2192°F
		J1	0.0~200.0°C/0.0~392.0°F	J2	0.0~400.0°C/0.0~752.0°F	J3	0~600°C/0~1112°F
	J	J4	0~800°C/0~1472°F	J5	0~1000°C/0~1832°F	J6	0~1200°C/0~2192°F
		R1	0~1700°C/0~3092°F				
	S1	0~1700°C/0~3092°F					
	B1	0~1820°C/0~3308°F					
	E1	0~800°C/0~1472°F					
	N1	0~1300°C/0~2372°F					
	T1	0.0~200.0°C/0.0~392.0°F	T2	0.0~400.0°C/0.0~752.0°F			
	W3	0~2300°C/0~4172°F	W5	0~2000°C/0~3632°F			
	PL-II	PL2	0~1390°C/0~2534°F				
Platinum Resistance	Pt100 DIN	PT1	-199.9~200.0°C/-199.9~392.0°F	PT2	-199.9~400.0°C/-199.9~752.0°F	PT3	-199.9~600.0°C/-199.9~1112.0°F
		PT4	0~200°C/0~392°F	PT5	0~400°C/0~752°F	PT6	0~600°C/0~1112°F
	Pt100 JIS	JP1	-199.9~200.0°C/-199.9~392.0°F	JP2	-199.9~400.0°C/-199.9~752.0°F	JP3	-199.9~600.0°C/-199.9~1112.0°F
		JP4	0~200°C/0~392°F	JP5	0~400°C/0~752°F	JP6	0~600°C/0~1112°F
	Analog Signal	10mV	An10	-1999~9999/10mV			
		20mV	An20	-1999~9999/20mV			
50mV		An50	-1999~9999/50mV				
Other		USER	-1999~9999/(4~20mA, 1~5V, 0~10V,....)				

Parameter setting

The interior parameters of the controller can be divided into 3 groups according to their properties (LEVEL1~LEVEL3) so as to make settings more convenient. The setting authorities of groups are restricted with the parameter LOCK. LEVEL1 is User's Parameter Group, the group of parameter that are changed most often. LEVEL2 is controlling Parameter Group. Parameters about auto controlling are gathered up there. LEVEL3 is I/O Group (input/output), such parameters are the change of sensor, adjustment of analog output, and communication are gathered here.

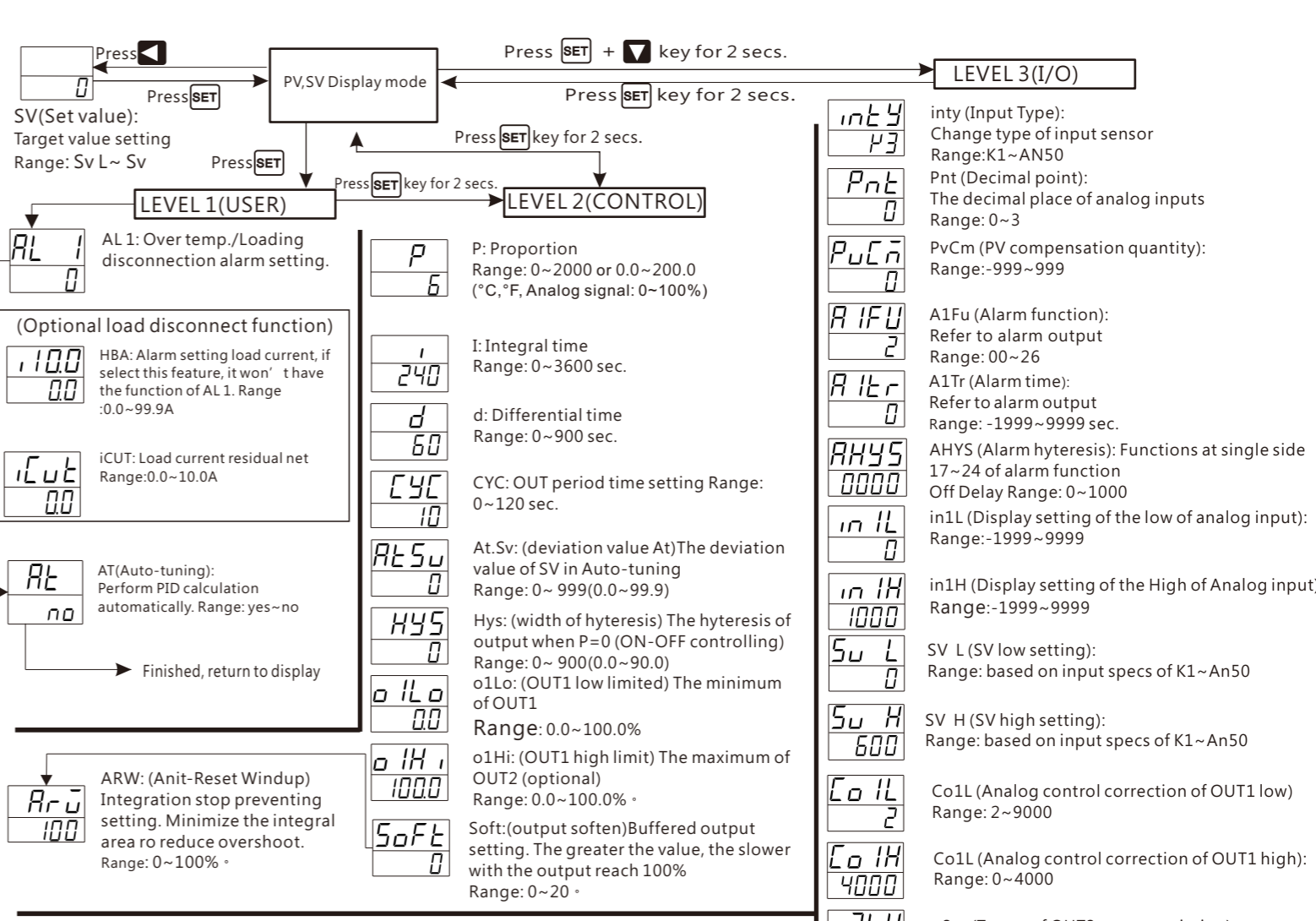

Parameter protection setting

Press **SET** + **▲** key for 2 secs.
 Lock parameter protection:
 0: all parameter can't be set
 1: only SV can set
 2: only LEVEL 1, manual/auto switch open
 3: only LEVEL1, 2 open
 4: all open

Manual/Auto switch

press **▲** 2 secs. to enter manual mode, (A/M) light on, repress **▲** for 2 secs. to return back to auto control mode. When enter manual mode, upper row will display PV value, lower row will display "Mout". Can adjust the output via the panel keys as follows.
 Press **▲** to start to adjust output
 Range: 0.0~100.0% Re-press **SET** key to complete the adjustment

Anomalies and troubleshooting

Exception code	Description	Disposal
oPEn	Temperature sensor disconnection	1. If connection terminal and wire has no problem, please remove the wire end. If the controller input short circuit (thermocouple is suitable for this method), please check the PV value. If it's displayed as room temperature value, it should be temperature sensor failure.
oL	Input signal over + display value	2. Or on the input end to across 100 OHM (PT100 is suitable for this method), observe the display value to see if displays 0
-oL	Input signal over - display value	
CUEr	Diode temperature compensation failure	Repair
AdEr	Internal circuit failure	Repair

tout (time out) Communication timing out: Range: 5~99 sec.

mode (Modbus communication mode): Range: RTU, ASCII

Alarm output features

There are 26 types of alarm outputs, represented with codes 00~26. 00 represents alarm disabled; odd numbers represents that the first output after start up is disable. 25 & 26 are exclusive alarm output for process control.

Code: 01, 02 Relative high alarm		Code: 03, 04 Relative deviation high
Code: 05, 06 Relative low alarm	Code: 07, 08 Relative deviation low	
Code: 09, 10 Band alarm	Code: 11, 12 Low alarm	Code: 13, 14 High alarm
Code: 15, 16 Deviation high/low	Code: 17, 18 Deviation low alarm	Code: 19, 20 Deviation high alarm
Code: 21, 22 Process low alarm	Code: 23, 24 Process high alarm	Code: 25, 26 Process control

Alarm output time setting:

Parameter A1Tr sets the duration of alarm output. Its ranging from -1999 sec. to +9999 sec. Time of +/- setting has different meaning on output.

1. If set minus value ex. -9, represents alarm will be **delayed** 9 second output.
2. If set 0 second, alarm will immediate output.

1. This control can provide 1 alarm setting (can set 3 sets through communication, see communication spec.).
The operations of alarm of High & Low are as follows: (taking function 02 with ALM set as 0 as example)
High (Right) condition: $(SV+ALM) > PV$
Low (Left) condition: $(SV-ALM) \leq PV$
2. If the feature code is set in 1~16, alarm value will be calculated as absolute value (turn minus to positive to calculate)
3. If the controller is equipped with HBA (broken-line alarm) function, then AL1 is HBA output, and function code is forced as 22. Users can not change. Only delay time (A1Tr) is reserved for setting. Range: -1 ~ -1999 sec.
4. For models with process control, if AL1 need to be assigned to make alarm output when the program completes each level, the alarm parameter can be set as 25, and set the value of AL1 to designate level numbers (0~15).
Note: For non-process-control models, if the function code is set as 25 & 26, the alarm will be invalid.

PID(Auto-Tuning)

Auto-Tuning employs the measure of Relay ON-OFF to detect the dynamic characteristics of the Process, and compute the best collection of P.I.D. parameter based on the data.
During Auto-Tuning, the operation must be under the situation where the Process is not interfered. When Auto-Tuning is completed, (AT lamp goes off), the three parameters, P.I.D. will renew themselves, and enter the new P.I.D. Auto-Tuning mode.

If any of the following situation occurs, Auto-Tuning will stop and enter Manual mode, but PID values will not be changed:

- Any exception occurs (including power failure)
- The half-period of the Process is over 2 hours.
- Hold for 2 sec. (forcing to Manual mode)

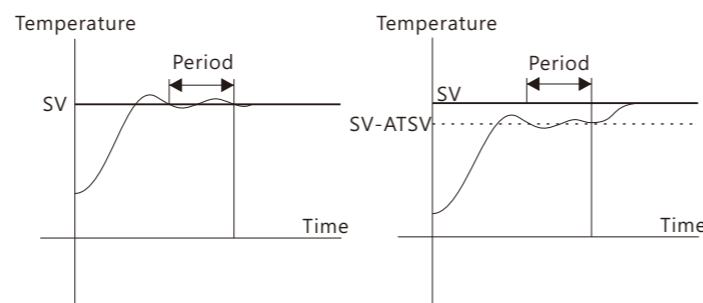

Dimension and Mounting (Unit: mm)

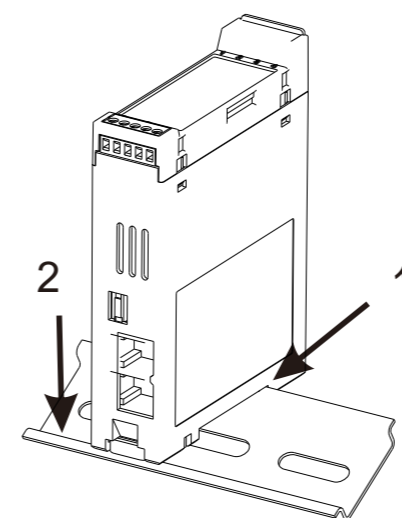

First, put the groove of controller back-end into the aluminum rail (as arrow 1). And then press the controller to connect to the aluminum rail (as arrow 2) until hearing the click sound.

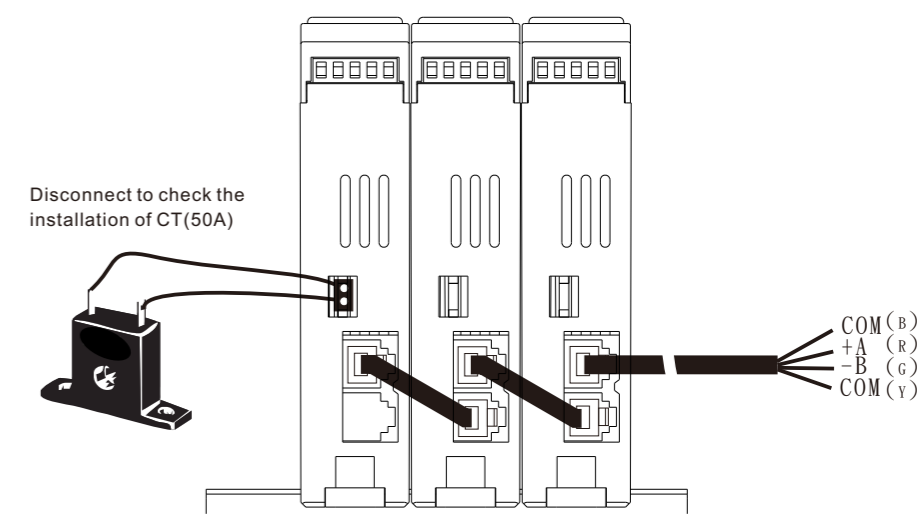
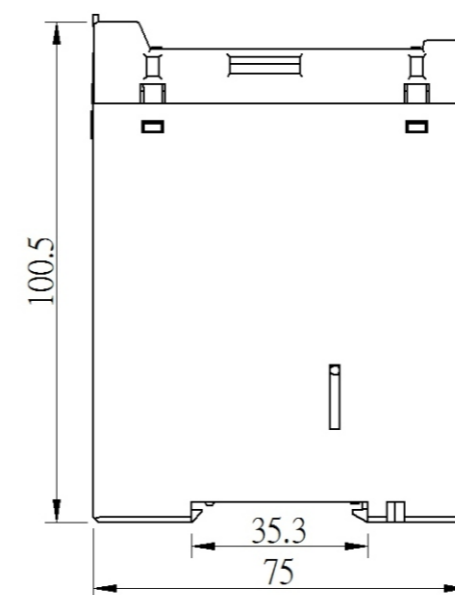

Installation for RS-485 communication wire, which can connect with at most 31pcs temperature controllers

Optional communication wire:

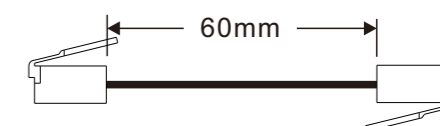

FL8-RJ12-001

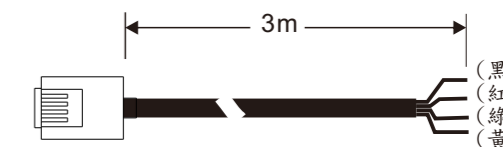

FL8-RJ12-002

Wiring diagram

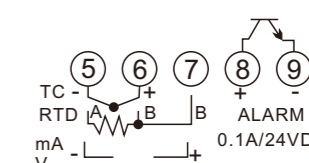
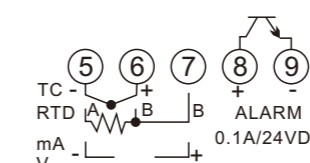
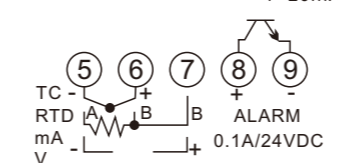
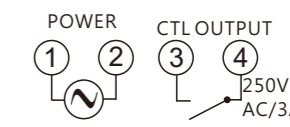
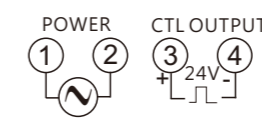
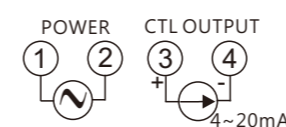

8.8.8.8
8.8.8.8

8.8.8.8
8.8.8.8

8.8.8.8
8.8.8.8

