

LOW NO_x MAXIM • PACKAGED GAS WATER HEATER

NICKELSHIELD® NICKEL-PLATED STORAGE TANK

119 GALLON TANK SERIES

MODEL NUMBER	20 N 119A-MXS
GPH Recovery at 40° to 120° F	245
GPH Recovery at 40° to 140° F	195
Input Btu/h	199,000
Minimum gas inlet pressure – " W.C.	5.5
A Cold Inlet - NPT	2
B Hot Outlet - NPT	2
C Drain - NPT	1
D I - Beam Skids	3 X 34-1/2
E Overall Depth	47
F Overall Height	75
G Flue Outlet Diameter	5
H Gas Inlet - NPT	1/2
J Motor HP 120 V, 1Ø, 60 Hz.	1/6
Motor Amps	1.75
L Height to Outlet	65
M Height to Inlet	28
Approx. Shipping Weight - lbs	1070

Recoveries based on 82% thermal efficiency. ASHRAE 90.1 compliant.
Dimensions are in inches unless otherwise specified.
For standard and optional equipment, see Form # PV6382.

1. Control Enclosure
2. ASME Temperature & Pressure Relief Valve
3. 3" NPT Handhole

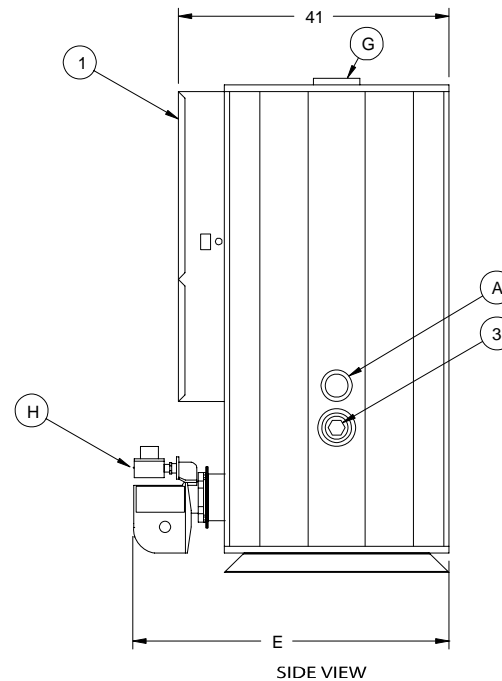
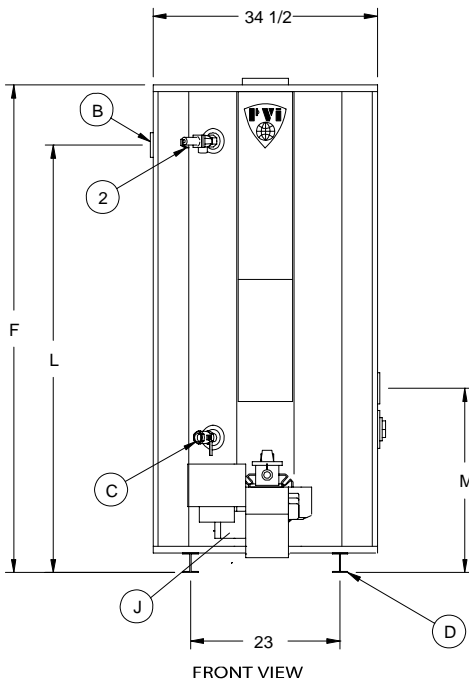

STANDARD GAS PRESSURE REQUIREMENTS:

SEE TABLE FOR MINIMUM PRESSURE BY MODEL NUMBER.
MAXIMUM STATIC PRESSURE: 9" W.C.
FOR GAS PRESSURES OUTSIDE OF THIS RANGE,
CONTACT YOUR PVI REPRESENTATIVE.

STANDARD ELECTRICAL REQUIREMENTS:

CONTROL VOLTAGE: 120V, 1Ø, 60 HZ., 2 AMPS

VENTING REQUIREMENTS:

-.02" TO -.06" W.C. (NEGATIVE PRESSURE).
TYPE B VENTING.
THE ENTIRE VENT SYSTEM SHOULD NEVER BE SIZED BASED UPON THE VENT CONNECTION DIAMETER EXCLUSIVELY.
FOR PROPER VENT SIZING, CONSULT THE NATIONAL FUEL GAS CODE UNDER "FAN-ASSISTED".

PVI RESERVES THE RIGHT TO CHANGE THE DESIGN AND SPECIFICATION WITHOUT NOTICE.



PVI INDUSTRIES, LLC
FORT WORTH, TEXAS 76111
(800) 784-8326 • www.pvi.com

Product is patented in the U.S., Canada, and Mexico.

