



User Guidelines for Pressure Area Care Mattresses and Cushions

QUATTRO® ACUTE Systems

QUATTRO® PLUS Systems

QUATTRO® OVERLAY Systems

PULSAIR® CHOICE Systems

POLYFLOAT SUPREMA™

POLYFLOAT DORMIRA™

B.A.S.E.® Seating Systems



Explanation of Label Symbols and Statements



Caution



Refer to instructions of use / booklet



Medical Devices Directive 93/42/EEC



North America ETL listed



Class II Equipment (Double Insulated)



Do not dispose of with the normal household waste (*please refer to www.talleygroup.com for further details*)



Manufacturer



Date of Manufacture



Fragile, handle with care



Protect from heat and radioactive sources



Temperature limitation



Humidity limitation



Atmospheric pressure limitation



Suitable for connection to type BF applied parts

WARNING

This is a statement that alerts the user to the possibility of serious injury or other adverse reactions with the use or misuse of the device

CAUTION

This is a statement that alerts the user to the possibility of a problem with the system associated with its use or misuse



Operating Instructions

IP21

IP: Ingress Protection

2: Protection against fingers or other object not greater than 80mm in length and 12mm in diameter

1: Protection from vertically dripping water

Contents

	Page
EXPLANATION OF LABELS SYMBOLS AND STATEMENTS	1
INTRODUCTION	2
CAUTIONS AND WARNINGS INFORMATION	3
ALTERNATING AIR PRESSURE MATTRESSES & CUSHIONS	
INSTALLATION AND USER GUIDELINES	5
CARE AND MAINTENANCE	10
FAULT FINDING	12
FOAM MATTRESSES & CUSHIONS	
INSTALLATION AND USER GUIDELINES	14
CARE AND MAINTENANCE	14
SPECIFICATIONS	16
EMI / EMC STATEMENT	18
EMC MANUFACTURER'S DECLARATION	BACK COVER

Introduction

Thank you for choosing to use a Talley pressure area care product, effective for the prevention and management of pressure ulcers.

The range of alternating air pressure products is as follows:-

- QUATTRO® ACUTE: mattress replacement system for patients at very high risk of pressure ulcers (also available in a cot size version for paediatric use)
- QUATTRO® PLUS: mattress replacement system for patients at high risk of pressure ulcers
- QUATTRO® OVERLAY: mattress overlay system for patients at high risk of pressure ulcers
- PULSAIR® CHOICE mattress replacement: for patients at high risk of pressure ulcers
- PULSAIR® CHOICE mattress overlay: for patients at medium risk of pressure ulcers
- PULSAIR® CHOICE cushion: for patients at medium risk of pressure ulcers
- B.A.S.E.® SEQUENTIAL: seat cushion for patients at very high risk of pressure ulcers
- B.A.S.E.® RECLINER MAT™: seat and back cushion for patients at very high risk of pressure ulcers

The range of static foam products is as follows:-

- POLYFLOAT SUPREMA™: mattress replacement for patients at risk of pressure ulcers
- POLYFLOAT DORMIRA™: mattress replacement for patients at risk of pressure ulcers
- POLYFLOAT™ cushion: for patients at risk of pressure ulcers

Cautions and Warnings



CONTRAINDICATIONS FOR USE

Alternating pressure therapy should not be used for patients with unstable fractures, gross oedema, burns or an intolerance to motion.

- There are no special skills required to operate the system.
- The medical professional is responsible for applying his/her best medical judgment when using this system.
- Select correct setting for therapy required. Care should be taken not to accidentally change pressures once set as the efficiency of the therapy may be reduced. This could also be caused by pets, pests or children.
- The electricity supply is of the type indicated on the power unit
- Check the mains lead is free from damage and is positioned so as not to cause an obstruction, or injury, e.g. strangulation.
- Ensure the mains lead or pump cannot become trapped or crushed, e.g. via raising or lowering of bed or bed rails or any other moving object.
- The power unit must only be used with a suitable approved cord and plug set as supplied by Talley.
- The system is not used in the presence of flammable anesthetics
- Suitable for continuous use.
- Not suitable for sterilisation.
- Do not position the power unit to make it difficult to disconnect the power supply, plug or garments.
- Do not place device on or near a heat source.
- Do not use with hot water bottles or electric blankets.
- The materials used in the manufacture of all components of the system comply with the required fire safety regulations.
- Talley advice against smoking whilst the system is in use, to prevent the accidental secondary ignition of associated items which may be flammable, such as bed linen.
- Do not allow sharp objects to penetrate the mattress material.
- Do not modify the mattress or power unit in any way.
- Do not store in damp conditions.
- Not for use in an oxygen enriched environment.
- Not for use in an outdoor environment.

- Intended for home healthcare use and professional healthcare facility environments where operators with medical training are continually available when patients are present.
- The device is intended to be hung over the beds footboard.
- Wireless equipment such as mobile phones should be kept at least 10 feet or 3.3 meters away from the equipment.
- Do not connect to any other medical device or equipment.
- Risk of fire if incorrect fuse used.
- The mattress and pump should be cleaned between patient use, please refer Care and Maintenance section for all warnings and cautions.
- Mattress must be properly set up as directed.
- Select correct setting for occupant weight.
- All hoses must be free of kinks, twists, properly connected and positioned so as not to cause an obstruction or injury.
- In order for alternating air pressure mattress/cushion range to operate effectively, please avoid placing objects on the surface that may obstruct the movement of air between the cells. For the same reason, please discourage people from sitting on the edge or on the end of the mattress whilst it is in use.
- Do not use bleach, chlorine releasing agents in concentrations over 1000 ppm, solvents or alcohol-based cleansers, e.g. Phenicol, Hibiscrub, Clearsol, Stericol, Hycoline as these will destroy the mattress material.
- Do not place heavy objects on the surface of foam mattresses when not in use.
- The system is used as part of a pressure ulcer prevention program, not solely relied upon for this purpose.
- It should be noted that the use of a cushion will increase the patient's seated height by approximately 5cm, and care should be taken to ensure the patient's comfort and security regarding height of foot and arm rests.
- The above warnings, cautions and any safety considerations should be observed on a routine and regular basis, not only upon installation.

Alternating Air Pressure Mattresses & Cushions

Installation and User Guidelines

INSTALLING MATTRESSES

1. If using a mattress replacement system, which is intended to completely replace the bed mattress, remove any existing mattress from the bed frame. If using a mattress overlay system, ensure bed frame to be used has an existing mattress in place.
2. Place the mattress on the bed frame/existing bed mattress. If using a powered mattress ensure the mattress hose exits at the foot end on the right hand side and the coloured cover is uppermost.
3. Secure the mattress to the bed frame/existing mattress using adjustable straps - pass straps beneath or around bed frame mattress platform/ bed mattress and secure with the buckles (Fig. 1), allowing for moving components on electric bed frames. This is important as it stops the mattress becoming detached from the bed frame/existing bed mattress and causing possible injury to the patient. A strap extension kit is available for use with divan beds (part number 97-50-10-153).
4. Suspend the power unit from the foot board of the bed having first adjusted the hanger brackets as instructed at the rear of the unit. Alternatively the power unit may be placed on the floor.
5. Attach the air supply hose to the power unit by aligning the black line on the air supply hose connector with the black line on the power unit connector and pushing together. Rotate the mattress hose connector clockwise until the green indicator fills the indicator hole on the power unit connector (Fig. 2).
6. Plug the smaller end of the power lead into the left hand side of the power unit, and the other end into mains outlet in wall. Ensure that the mains lead and tubing cannot become trapped in the bed frame.
7. Switch the power on at the outlet, and at the side of power unit adjacent to the power lead entry.
8. The system will display STARTING, then INITIALISING whilst the mattress inflates (this will take between 15 - 20 minutes).

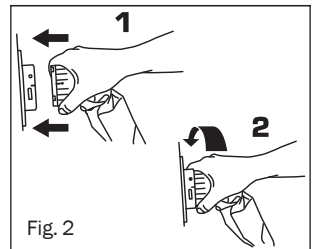
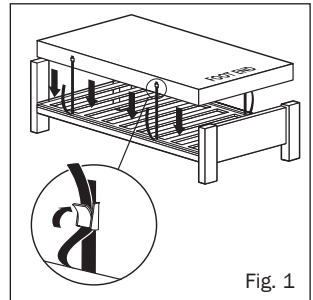

Note: It is important that during the INITIALISING phase the mattress connector is not disconnected from the power unit. If this is done, the power unit must be switched off, MUTE button pressed when the sounder is heard, the mattress connector re-engaged, and the power unit restarted. If UNCALIBRATED is displayed when switched on, the system will continue to operate but should be recalibrated as soon as possible.

9. When a bottom sheet is added to the mattress, ensure that it is left loose to allow the mattress surface to conform with the patient's body as much as possible.
10. Allow the mattress to inflate before positioning the patient on the mattress.
11. Once inflated the system will automatically default to ACTIVE mode. CONTINUOUS LOW PRESSURE therapy can be selected via the THERAPY MODE button (please see THERAPY MODE on page 7). The comfort setting can be adjusted using the up and down arrow buttons (see COMFORT CONTROL on page 7).

NB. The power unit will automatically lock 2 minutes after last button operation when running to prevent inadvertent operation of button functions (except MUTE), as indicated by 'L' on the display screen. Press and hold the MUTE/UNLOCK button until power unit beeps if further button operation is needed (i.e. change of therapy mode or comfort setting).

12. Place the carry bag and user manual in a safe place for future use.

INSTALLING CUSHIONS

The QUATTRO® PLUS, QUATTRO® OVERLAY AND PULSAIR® CHOICE power units can all be used to operate their respective alternating air pressure cushions. Place the cushion on a chair, ensuring that it is placed the correct way up with the BACK labelling (if applicable) facing the back of the chair. Secure cushion to chair using adjustable straps, where available.

1. The PULSAIR® CHOICE cushion is connected to the PULSAIR® CHOICE power unit exactly as described in points 5. to 8. above and will take approx. 30 seconds to inflate.
2. The B.A.S.E.® SEQUENTIAL and B.A.S.E.® RECLINER MAT cushions can be used with the QUATTRO® PLUS and QUATTRO® OVERLAY mattress systems, either operated with the mattress or, using a cushion adaptor, directly with the power unit, as follows:-

- a) To use the cushion directly with the power unit, connect the cushion adaptor to the power unit, rotating the adaptor clockwise until the green indicator fills the indicator hole on the power unit connector. Connect the air supply hose from the cushion onto the adaptor, matching up the alignment markings (Fig. 3). Ensure that this has been

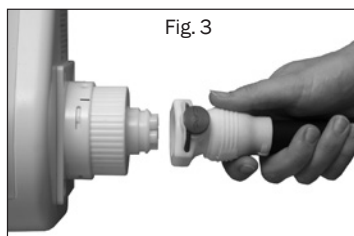

correctly clicked into place, otherwise a leak may occur. Attach the power lead, plug into the mains outlet and switch the power on at the side of power unit adjacent to the power lead entry. Once inflated (approx. 5 minutes) increase the comfort control setting to SEATED using the UP arrow button.

NB. If using the power unit from an operating mattress system, first press the MAX. INFLATE button to fully inflate the mattress, then rotate the air supply hose connector anti-clockwise and detach from the power unit to seal the air within the mattress to leave it fully inflated. To reconnect the mattress to the power unit after using the cushion, switch off the power unit and disconnect the cushion adaptor. Re-connect the mattress air supply tubing to the power unit, and switch on the power unit (operation will automatically default to Active mode).

- b) To use the cushion whilst the mattress is operating, simply attach the air supply hose from the cushion to the connection port on the side of the head end of the mattress by matching up the alignment markings and pushing together the CPC connectors until they **click into place** (Fig. 4), increasing the comfort control setting to SEATED. The mattress and cushion will operate simultaneously, allowing the simple transfer of the patient between the bed and chair. NB. When the patient is in bed, return the comfort setting to the mattress settings of SOFT, MEDIUM or FIRM.

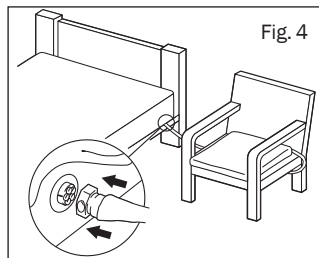

It should be noted that the use of an alternating air pressure cushion will increase the patient's seated height by approximately 5cm, and care should be taken to ensure the patient's comfort and security regarding height of foot and arm rests.

OPERATION BUTTONS

The operation buttons on the face of the power unit provide the following functions.



OTHER THERAPY MODE

Pressing the THERAPY MODE button will toggle between ACTIVE (1 in 4 alternating air pressure cycle) and CONTINUOUS LOW PRESSURE therapy modes. The selected therapy mode is shown on the display screen. The default mode is ACTIVE therapy. To switch to CONTINUOUS LOW PRESSURE mode, press THERAPY MODE button for 2 seconds until an audible tone is heard. The system will then display 'PLEASE WAIT' and requires approximately 2 minutes to initialise.



COMFORT CONTROL



Air pressure is regulated within each of the cells throughout the cycle so that support, posture and therapy are constantly maintained at optimum levels, in response to patient weight, movement and position. Equalisation of cell pressure automatically takes place at each stage of the 1-in-4 cycle, again to ensure precise pressure

and therapy is provided. The automatic default comfort setting is MEDIUM (with the exception of the QUATTRO® ACUTE PAEDIATRIC mattress, which defaults to SOFT). However, if the patient prefers a firmer or softer mattress, increase or decrease the comfort control setting accordingly using the UP and DOWN arrow buttons (SOFT/MEDIUM/FIRM). The comfort setting is shown on the display screen. Check periodically to ensure patient support and comfort.



DATA

Pressing the DATA button at any time switches the display into DATA mode. Use the up and down arrow buttons to scroll through the product data and user information set. Pressing the DATA button again returns the display to the previous mode.

NB. Used for accessing information only, does not affect mode of operation.



MUTE/UNLOCK

Press to silence the sounder and to clear the message from the display screen. The power unit will automatically lock 2 minutes after the last button operation when running to prevent the inadvertent operation of button functions (except MUTE), as indicated by 'L' on the display screen. Press and hold the MUTE/UNLOCK button until the power unit beeps if further button operation is needed (i.e. comfort setting). The power unit will lock again 2 minutes after the last button operation.

NB. After power failure/switching the power off, pressing MUTE cancels the system's previous settings. When power returns the default setting of ACTIVE mode, comfort setting 3 is invoked. (Note that previous settings are automatically cancelled if the duration between switch off and switch on is greater than 12 seconds. If power returns before a period of 12 seconds has passed and the MUTE button has not been pressed, the system will return to the previous mode of operation.)



MAX. INFLATE

Necessary for some nursing procedures, the MAX INFLATE mode inflates the mattress to maximum static pressure for a period of 15 minutes. After pressing the MAX INFLATE button to inflate mattress, the system displays 'PLEASE WAIT' followed by 'READY' and a 5 second audible tone when maximum pressure is achieved and 'MAX INFLATE' is shown on the display screen. After 15 minutes the system automatically returns to the Active mode of operation.

MAXIMUM USER WEIGHT GUIDELINES

QUATTRO® ACUTE:- 250kg (39 stone) max. (PAEDIATRIC version:- 95kg (15 stone) max.)

QUATTRO® PLUS and PULSAIR® CHOICE mattress replacement:- 200kg (31 stone) max.



QUATTRO® OVERLAY:- 160kg (25 stone) max.

PULSAIR® CHOICE mattress overlay:- 127kg (20 stone) max.

B.A.S.E.® SEQUENTIAL and B.A.S.E.® RECLINER MAT cushions:- 127kg (20 stone) max.

PULSAIR® CHOICE cushion:- 102kg (16 stone) max.

CPR FACILITY (Fig. 5)

The CPR device is situated at the head end on the right hand side of the mattress (viewed from foot end), as indicated by arrows on the mattress tag. For rapid deflation rotate the dial of the CPR device anti-clockwise to 'click' into the open position . If re-inflating the mattress, make sure the dial of the CPR device is rotated clockwise until it 'clicks' into the closed position .

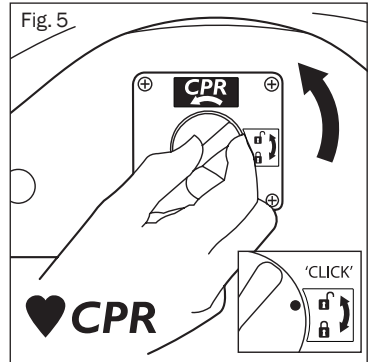

PATIENT TRANSPORT FACILITY (Fig. 6)

Press MAX. INFLATE button (if applicable) to fully inflate the mattress. When maximum pressure is achieved, detach the mattress air supply hose from the power unit by rotating the mattress hose connector anti-clockwise until the black lines align, and pull the mattress hose connector away. The mattress will remain inflated, so supporting the patient.

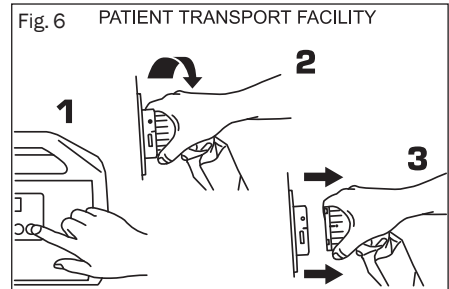

All alternating air pressure mattresses can be used on profiling bed frames, slatted frames, in-filled frames and divans.

Back rests or pillows for support should be placed beneath the mattress to allow uninterrupted body contact with the mattress surface.

Place the bottom sheet loosely on the mattress to allow the mattress surface greater contact with the patient's body. Avoid using fitted sheets. The use of incontinence sheets / excessive bedding beneath the patient may reduce the pressure relieving effect of the mattress.

To remove air from the mattress when dismantling the system, use the CPR facility as described above.

Care should be taken when raising and lowering bed safety side rails in order to avoid possible interference with the CPR and cushion connection port where fitted.

A gap of 2.5cm on either side of the mattress should not be exceeded when side rails are deployed.

Care and Maintenance



COVER

Always keep the mattress/cushion cover as clean as is practicable. The material is waterproof and vapour permeable.

- Inspect top cover for signs of damage or wear which could result in the contamination of the interior, e.g. tears, holes, damage to seams or zips, underside staining, etc. The frequency of these checks should be at each decontamination process, i.e. between patients or patient occupancy (or weekly for longer term patients).
- Care should be taken to avoid puncturing cover with objects such as needles, scalpels, pat slides, acrylic nails, etc.
- The cover may be removed and cleaned in accordance with The Revised Healthcare Cleaning Manual June 2009 subject to the following action: Following the use of a detergent and or disinfectant solution the mattress cover should be rinsed with clean water using a clean cloth and allowed to dry.
- Frequent or prolonged exposure to high concentrations of aggressive disinfectant solutions will reduce the useful life of the mattress/cushion cover.
- Where high concentration disinfectants e.g. $\geq 10,000\text{ppm}$ chlorine releasing agent (e.g. Haztab or bleach) or combined cleaning/chlorine releasing agent (e.g. Chlorclean, Actichlor) and detergent solutions are used to remove blood or other body fluids, mattresses/cushions should be thoroughly rinsed with clean water to remove any residues. This will help prevent any possible long term compatibility issues associated with disinfectant residues.*
- Alternatively disinfection may be achieved by laundering at temperatures not exceeding 65°C for 10 minutes or 73°C for 3 minutes which may include a chlorine rinse.
- Do not use abrasive cleaners, phenol disinfectants, solvents or alcohol-based cleansers, e.g. Dettol, Phenicol, Hibiscrub, Clearsol, Stericol, Hycoline, as these will destroy the cover materials.
- Do not iron.
- Ensure that the mattress/cushion is thoroughly dried before remaking the bed or placing in storage.

INTERIOR COMPONENTS

- Check air cells and mattress/cushion interior for signs of damage or contamination, e.g. staining or evidence of fluid ingress. The frequency of these checks should be at each decontamination process, i.e. between patients or patient occupancy (or weekly for longer term patients)
- Care should be taken to avoid puncturing air cells with objects such as needles, scalpels, pat slides, acrylic nails, etc.
- The individual cells can also be wiped clean with a mild antiseptic solution*.
- All cells are replaceable and can be obtained easily from Talley.
- Do not immerse the PULSAIR® CHOICE mattresses/cushion in water.
- The QUATTRO® range of mattresses are fully launderable, but ensure the CPR device is fully closed (i.e. the dial of the CPR device is rotated clockwise until it 'clicks' into the closed position ) , prior to laundering to prevent water entering the air cells/tubing.

POWER UNIT

Always disconnect the power unit from the electricity supply before carrying out maintenance, repairs, servicing or cleaning. Check all electrical connections and power lead for signs of excessive wear. The power unit can be wiped down with detergent or disinfectant solution or wipe*. Do not use solvents. Unsuitable for sterilisation. Disposal of the pump / mattress / cushion in accordance with the local regulations including WEEE requirements.

* In line with the MHRA Medical Device Alert (MDA/2013/019), Talley advises customers to use pH neutral, high level disinfectant cleaning products to sanitise reusable medical devices to prevent damage to materials and the degradation of plastic surfaces after prolonged use. The use of inappropriate cleaning and detergent materials on medical equipment could damage surfaces and may compromise the ability to decontaminate medical devices adequately or may interfere with device function. Talley recommends the use of TECcare® CONTROL antimicrobial wipes and fluid to clean and decontaminate all products it supplies to health and social care facilities. TECcare® CONTROL products provide class leading broad spectrum, high level disinfection with an exceptional safety profile. Being pH neutral TECcare® CONTROL can be universally used on all hard and soft surfaces without any detrimental effect. TECcare® CONTROL is CE marked for cleaning medical equipment.

SERVICING

Talley recommend that all power units should be serviced every two years or as indicated by the 'hours to service' display. The unit contains no user serviceable parts and should only be serviced by either Talley or an authorised dealer. Talley will make available on request service manuals, component parts lists and other information necessary for Talley, an authorised dealer or a competent electrical engineer to repair or service the system. Talley's standard terms and conditions apply to all sales. A copy is available on request. For service, maintenance and any questions regarding this, or any other product, please contact Talley.

It is the customer's responsibility to ensure the following prior to collection:

- the system is cleaned of any obvious contaminants.
- contamination status is documented.
- assistance is given to Talley personnel to bag the equipment if the mattress has been in a known or suspected infectious environment.

TRANSPORT AND STORAGE

Handle with care. Please report instances of damage or impact to Talley Service Department.
Transport

-25 °C without relative humidity control; and
+70 °C at a relative humidity up to 93 %, non-condensing.

An atmospheric pressure range of 700 hPa to 1 060 hPa.

Suitable for all standard modes of transport when in the correct packaging.

OPERATIONAL CONDITIONS

A temperature range of +5 °C to +40 °C;

A relative humidity range of 15% to 93%, non-condensing; and

Operational Atmospheric Pressure: 700 hPa to 1060 hPa

Suitable for pollution degree 2

Operational altitude \leq 2 000 m

IP Rating: IP21 pump only

TRANSPORTATION OF MATTRESS SYSTEM

The mattress should be loosely rolled lengthwise with the cover innermost, taking care not to strain the umbilical. It can then be transported and stored in the carry bag with the power unit, mains cable and this booklet. Do not stack bagged mattresses more than two high to avoid strain on the umbilical.

MANUFACTURER'S GUARANTEE

All power units, alternating mattresses/cushions and foam mattresses/cushions are covered by a 24 month manufacturer's guarantee. The intended design life is 5 years if fully serviced.

Fault Finding

The power unit can be reset by pressing the MUTE button once. This also silences the sounder and clears the message from the display screen. All systems have a fault log that records the last 5 faults via the DATA display mode. If problems reoccur contact Talley.

AC FAIL fault – indicates a mains power failure, a sounder will be heard if power is interrupted, e.g. power unit switched off, power cut, disconnection of mains lead. Press MUTE or re-connect to power supply.

ROTOR SYSTEM fault – indicates the automatic sequential cycle has stopped or there is a fault in the system. Switch power off, press MUTE button, then switch power on again. If the fault re-occurs, contact Talley.

LOW PRESSURE fault – indicates pressure has fallen below the minimum allowable levels. Check that the hose is connected to the power unit correctly. Check that the CPR device is fully closed, i.e. the dial of the CPR device is rotated clockwise until it 'clicks' into the closed position . Check that the internal cells are connected and that no cell is punctured. Press the MUTE button to clear the message and to silence the sounder. If the fault re-occurs, contact Talley.

EMI fault – indicates that the unit detects the pressure sensor amplifier is adversely affected by external RF fields. This will clear when interference ceases.

OTHER FAULTS

PUMP OR TRIAC fault - indicates a pump control failure or an open pump coil fault. Should this occur, contact Talley.

UNCALIBRATED - contact Talley for recalibration.

If you have any queries relating to this system please contact Talley or your local authorised dealer.

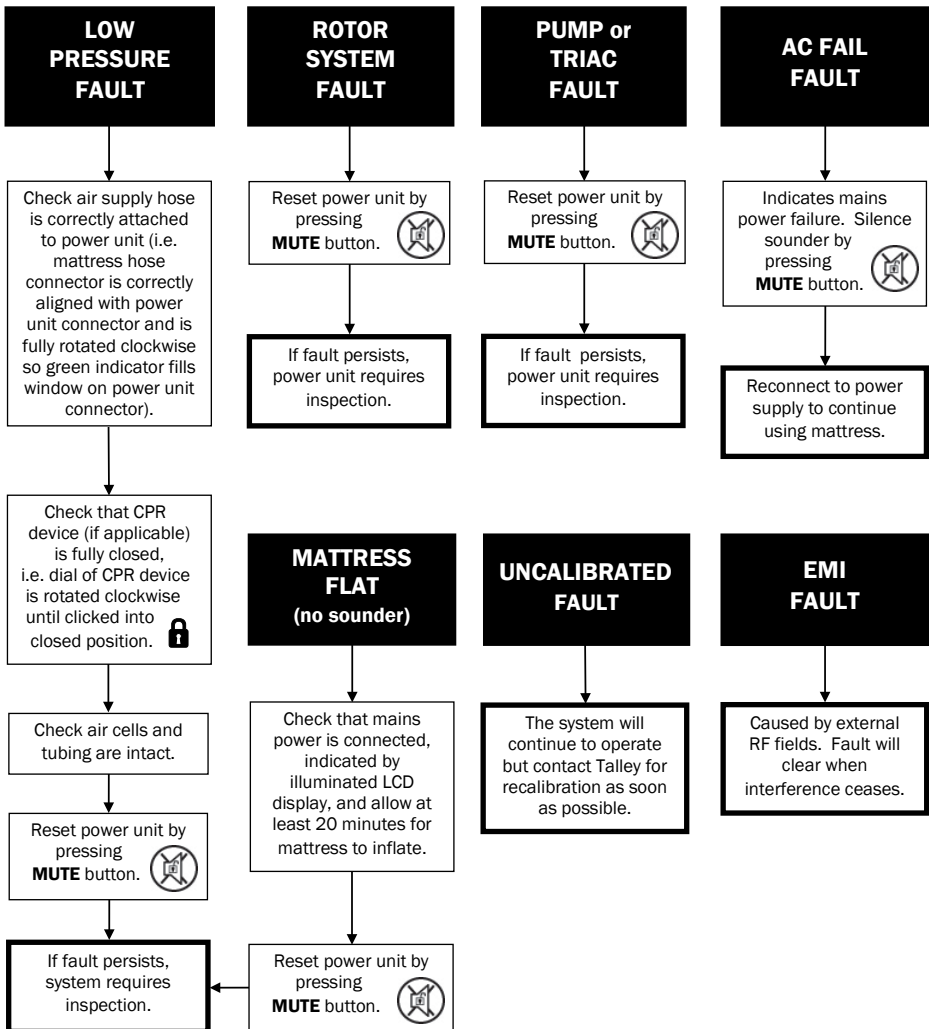

Static Foam Mattresses

Installation and User Guidelines

MATTRESSES

1. Ensure the bed frame to be used has no existing mattress components, and is free from items which could cause damage to the POLYFLOAT SUPREMA™ / POLYFLOAT DORMIRA™ mattress.

It should be noted that this mattress is intended to completely replace the existing mattresses.

2. Place the POLYFLOAT SUPREMA™/ POLYFLOAT DORMIRA™ mattress on the bed frame, with the printed cover uppermost and the non-slip base facing downwards.
3. Place the user manual in a safe place for future use.

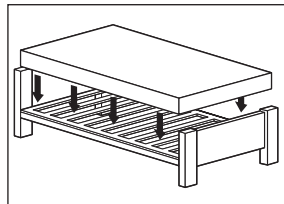

The POLYLOAT SUPREMA™ / POLYFLOAT DORMIRA™ mattress can be used on profiling bed frames, slatted frames, in-filled frames and divans.

A gap of 2.5cm either side of the mattress should not be exceeded when side rails are deployed.

CUSHIONS

Place the POLYFLOAT™ cushion onto a chair, ensuring cushion is placed the correct way up. N.B. It should be noted that the use of a foam cushion will increase the patient's seated height by approximately 5cm, and care should be taken to ensure the patient's comfort and security regarding height of foot and arm rests.

MAXIMUM USER WEIGHT GUIDELINES

POLYFLOAT SUPREMA™ mattress:- 127kg (20 stone) max.

POLYFLOAT DORMIRA™ mattress:- 127kg (20 stone) max.

POLYFLOAT™ cushion:- 102kg (16 stone) max.

Care and Maintenance



The POLYFLOAT SUPREMA™ / POLYFLOAT DORMIRA™ mattress / POLYFLOAT™ cushion will provide years of efficient service if it is cared for in the following way:

COVER

Always keep the mattress/cushion cover as clean as is practicable. The material is waterproof and vapour permeable.

- Inspect top cover for signs of damage or wear which could result in the contamination of the interior, e.g. tears, holes, damage to seams or zips, underside staining, etc. The frequency of these checks should be between patients or patient occupancy (weekly for longer term patients).
- Care should be taken to avoid puncturing cover with objects such as needles, scalpels, pat slides, acrylic nails, etc.
- The cover may be removed and cleaned in accordance with The Revised Healthcare Cleaning Manual June 2009 subject to the following action: Following the use of a detergent and or disinfectant solution the mattress cover should be rinsed with clean water using a clean cloth and allowed to dry.
- Frequent or prolonged exposure to high concentrations of aggressive disinfectant solutions will reduce the useful life of the mattress/cushion cover.
- Where high concentration disinfectants e.g. $\geq 10,000$ ppm chlorine releasing agent (e.g. Haztab or bleach) or combined cleaning/chlorine releasing agent (e.g. Chlorclean, Actichlor) and detergent solutions are used to remove blood or other body fluids, mattresses/cushions should be thoroughly rinsed with clean water to remove any residues. This will help prevent any possible long term compatibility issues associated with disinfectant residues.*
- Alternatively disinfection may be achieved by laundering at temperatures not exceeding 65°C for 10 minutes or 73°C for 3 minutes which may include a chlorine rinse.
- Do not use abrasive cleaners, phenol disinfectants, solvents or alcohol-based cleansers, e.g. Dettol, Phenicol, Hibiscrub, Clearsol, Stericol, Hycoline as these will destroy the cover materials.
- Do not iron.
- Ensure that the mattress/cushion is thoroughly dried before remaking the bed or placing in storage.

INTERIOR

- Inspect the mattress/cushion interior for signs of damage or contamination, e.g. staining or evidence of fluid ingress. The frequency of these checks should be at each decontamination process, i.e. between patients or patient occupancy (or weekly for longer term patients)
- Contaminated mattresses/cushions should be removed from service and disposed of in accordance with local policy.
- Regular turning will prolong the life of the mattress. The POLYFLOAT DORMIRA™ / POLYFLOAT SUPREMA™ mattress has a 2 way turning cycle. Please refer to instructions printed on cover.

SYSTEM DESIGN LIFE: 3 years

HANDLING AND STORAGE

Handle with care. Please report instances of damage or impact to Talley Service Department. The mattress should be stored flat.

Temperature: Operational: 10°C to 40°C

Storage: 10°C to 55°C

TRANSPORTATION OF MATTRESS SYSTEM

The mattress should be transported flat and not rolled. Mattresses should not be stored more than 6 high as this can potentially be a safety hazard when handling. To protect the covers, mattresses should be packed in minimum 200 micron clear polythene.

Specifications

ALTERNATING AIR PRESSURE POWER UNITS

Construction:	ABS Plastic
Dimensions:	335mm/13.2" x 233mm/9.2" x 165mm/6.5"
Weight:	3.4 kg / 7.5 lbs
Mains Cable:	5 metres / 16.5' For the USA:- only a hospital grade attachment plug with a 15A NEMAP 5-15 configuration and 18AWG hospital grade flexible cord is to be used, as supplied by Talley.
Electricity Supply:	230V ~ 50Hz (CE marked) 120V ~ 60Hz (cETLus listed) 230V ~ 60Hz
Rated Input:	9.4 VA
Fuse Rating:	T500mA 250V HRC (ceramic) 5 x 20 mm
IP Rating:	IP21
Cycle Time:	QUATTRO® ACUTE: variable (continuous) QUATTRO® PLUS: 16 minutes (continuous) QUATTRO® OVERLAY: 16 minutes (continuous) PULSAIR® CHOICE: 16 minutes (mattress replacement) / 8 minutes (mattress overlay/cushion) (continuous)

ALTERNATING AIR PRESSURE MATTRESSES

Construction:	BASE: QUATTRO® ACUTE / QUATTRO® PLUS / QUATTRO® OVERLAY: Woven nylon 940 DTEX PU coated both sides PULSAIR® CHOICE: PVC coated 2oz nylon, 350 micron CELLS: PU film COVER: PU coated stretch nylon 255g/m ²
Options:	Standard / Long / Narrow
Type:	QUATTRO® ACUTE / QUATTRO® PLUS / PULSAIR® CHOICE MATTRESS REPLACEMENT: Orthodifferential TISSUEgard™ pleated air cells operating in a 1-in-4 alternating air pressure cycle QUATTRO® OVERLAY: Orthodifferential air cells operating in a 1-in-4 alternating air pressure cycle PULSAIR® CHOICE mattress overlay: Orthodifferential air cells operating in a 1-in-2 alternating air pressure cycle
Dimensions	QUATTRO® ACUTE: 2040mm x 920mm x 240mm (PAEDIATRIC version: 1300mm x 670mm x 180mm)

(UK standard size - approx.
max. top surface, inflated
*/- 2%

QUATTRO® PLUS/PULSAIR® CHOICE MATTRESS REPLACEMENT:

1970mm x 900mm x 180mm

QUATTRO® OVERLAY/ PULSAIR® CHOICE MATTRESS OVERLAY:

1920mm x 900mm x 130mm

Weight:

QUATTRO® ACUTE: 12.5kg (PAEDIATRIC version: 5.8kg) ■ QUATTRO® PLUS: 9.4kg ■ QUATTRO® OVERLAY: 6.3 kg ■ PULSAIR® CHOICE: 8.0kg (mattress replacement) / 5.5kg (mattress overlay)

ALTERNATING AIR PRESSURE CUSHIONS

Construction:

BASE: B.A.S.E.* SEQUENTIAL / RECLINER MAT cushion: Woven nylon 940 DTEX PU coated both sides ■ PULSAIR® CHOICE cushion: PVC coated 2oz nylon, 350 micron

INNER: B.A.S.E.* SEQUENTIAL / RECLINER MAT cushion: PVC bellows within punched CMFR foam ■ PULSAIR® CHOICE cushion: PU film

COVER: PU coated stretch nylon 255g/m²

Type:

B.A.S.E.* SEQUENTIAL / RECLINER MAT cushion: 8/20 rows of 6 bellow cell strips operating in a 1-in-4 alternating air pressure cycle
PULSAIR® CHOICE cushion: One piece air cell set operating in a 1-in-2 alternating air pressure cycle

Dimensions

B.A.S.E.* SEQUENTIAL cushion: 430mm x 430mm x 70mm

(UK standard size)

B.A.S.E.* RECLINER MAT™ cushion: 1080mm x 430mm x 70mm
PULSAIR® CHOICE cushion: 430mm x 430mm x 40mm

Weight:

B.A.S.E.* SEQUENTIAL cushion: 1.9kg; ■ B.A.S.E.* RECLINER MAT cushion: 3.9kg ■ PULSAIR® CHOICE cushion: 1.3kg

STATIC FOAM MATTRESSES & CUSHIONS

Construction:

POLYFLOAT SUPREMA™ mattress: base frame - CMHR foam 38-40kg/m³/175-215 (blue); insert - Visco-elastic foam 57-62kg/m³/42-58 (yellow) with channel-cut head and foot areas

POLYFLOAT DORMIRA™ mattress: base frame - CMHR foam 38-40kg/m³/175-215 (blue); insert - CMHR foam 38-40kg/m³/110-130 (orange) with variable width castellated surface

POLYFLOAT™ cushion: base layer - CMHR foam 48-52kg/m³/200-260 (white); top layer - Visco-elastic foam 57-62kg/m³/115-155 (pink) with cross-cut surface

Cover:

PU coated stretch nylon 255g/m²

Dimensions

POLYFLOAT SUPREMA™ mattress: 1980mm x 880mm x 150mm

POLYFLOAT DORMIRA™ mattress: 1980mm x 880mm x 150mm

POLYFLOAT™ cushion: 430mm x 430mm x 76mm

Weight:

POLYFLOAT SUPREMA™ mattress: 14.0kg

POLYFLOAT DORMIRA™ mattress: 11.0kg

POLYFLOAT™ cushion: 1.0kg

Turning cycle:

POLYFLOAT SUPREMA™ mattress: 2 way

POLYFLOAT DORMIRA™ mattress: 2 way

POLYFLOAT™ cushion: 2 way

EMI/EMC Statement and Manufacturer's Declaration

This equipment has been tested and found to comply with the limits of EN 60601-1-2 2001.

These limits are designed to provide reasonable protection against harmful interference in both a medical and residential environment. This equipment generates, uses and can radiate radio frequency energy and, if not used in accordance with manufacturer's instructions, may cause harmful interference to radio communications. However, there is no guarantee that interference will not occur in a particular installation. If this equipment does cause harmful interference to radio or television reception or other equipment, which can be determined by turning the equipment off and on, the user is encouraged to try to correct the interference by one of the following measures:

- Reorient or relocate the receiving antenna.
- Increase the separation between the equipment.
- Connect the equipment to an outlet on a circuit different from that to which the receiver or equipment was connected.

The equipment having been tested to operate within the limits of electromagnetic compatibility. (Immunity to interference from nearby sources radiating radio frequency energy). Sources exceeding these limits may give rise to operation faults. Where possible the system will sense the interference and if it is of short duration transparently take countermeasures whilst operating near normally, or failing this will issue a warning and take measures for the continued safety of the user. Further increased levels of energy may cause the system to stop operating, continuously generate random faults or continuous resets.

Try to ascertain the source of the interference by turning nearby or suspect equipment off, and see if the interference effects stop. In any such event the user is encouraged to try to correct the interference by one of the following measures:

- Have the interfering equipment repaired or replaced.
- Reorient or relocate the interfering equipment.
- Increase the separation between the equipment and the possible source of the interference.
- Connect the equipment to an outlet on a circuit different from that to which the interfering equipment was connected.

Information regarding Electro Magnetic Compatibility (EMC) according to IEC60601-1-2:2001, clause 6.8

With the increased number of electronic devices such as PC's and mobile telephones, medical devices in use may be susceptible to electromagnetic interference from other devices. The EMC (Electro Magnetic Compatibility) standard IEC60601-1-2 defines the levels of immunity to these electromagnetic interferences. From the other hand, medical devices must not interfere with other devices. IEC60601-1-2 also defines the maximum levels of emissions for these medical devices. The QUATTRO® conforms to this IEC60601-1-2 standard for immunity and emission. Nevertheless, special precautions need to be observed:

- The QUATTRO® needs to be installed and put into service according to the EMC information below.
- The QUATTRO® is intended for use in the electromagnetic environment specified in the tables below. The user of the QUATTRO® should assure that it is used in such environment.
- In general, although the QUATTRO® complies too the EMC standards, it can be affected by portable and mobile RF communications equipment (such as mobile telephones).
- The QUATTRO® should not be used adjacent to or stacked with other equipment. In case adjacent or stacked use is necessary, the QUATTRO® should be observed to verify normal operation.

Guidance and Manufacturer's Declaration: Electromagnetic Emissions (IEC 60601-1-2)		
Emissions Test	Compliance	Electromagnetic environment - guidance
RF emissions CISPR 11	Class B	The QUATTRO® systems are suitable for use in all establishments, including domestic establishments and those directly connected to the public low-voltage pump supply network that supplies buildings used for domestic purposes.
Harmonics emissions 61000-3-2	Class A	
Voltage fluctuations / flicker emissions 61000-3-3	Complies	

Guidance and Manufacturer's Declaration: Electromagnetic Immunity (IEC 60601-1-2)			
Immunity Test	IEC 60601 Test Level	Compliance Level	Electromagnetic Environment - Guidance
Electrostatic discharge (ESD) IEC 61000-4-2	± 6kV contact ± 8kV air	± 6kV contact ± 8kV air	Floors should be wood, concrete or ceramic tile. If floors are covered with synthetic material, the relative humidity should be at least 30%.
Electrical fast transient/burst IEC 61000-4-4	± 2 kV For mains supply lines ± 1kV For input/output lines	± 2 kV For mains supply lines ± 1kV For input/output lines	Mains supply quality for the mains adapter should be that of a typical commercial and/or hospital environment.
Surge IEC61000-4-5	± 1kV line(s) to line	± 1kV line(s) to line	Mains supply quality for the mains adapter should be that of a typical commercial and/or hospital environment.
Voltage dips, short interruptions and voltage variations on mains supply IEC 61000-4-11	<5%Ur (>95%Ur) for 0.5 cycle	<5%Ur (>95%Ur) for 0.5 cycle	Mains power quality should be that of a typical commercial and/or hospital environment. If the user of the QUATTRO® requires continued operation during power mains interruption, it is recommended that the QUATTRO® be powered from an uninterruptible power supply or battery.
	40%Ur (60% dip in Ur) for 5 cycles	40%Ur (60% dip in Ur) for 5 cycles	
	70%Ur (30% dip in Ur) for 25 cycles	70%Ur (30% dip in Ur) for 25 cycles	
Mains frequency (50/60Hz) magnetic field IEC61000-4-8	3 A/m	3 A/m	Mains frequency magnetic fields should be at levels characteristic of a typical location in a typical commercial and/or hospital environment.

Note: Ur is the A.C. mains voltage prior to application of the test level.

Guidance and Manufacturer's Declaration: Electromagnetic Immunity (IEC 60601-1-2)			
Immunity Test	IEC 60601 Test Level	Compliance Level	Electromagnetic Environment - Guidance
Conducted RF IEC 61000-4-6	3 V rms 150 kHz ~ 80 MHz	3 V rms	Portable and mobile RF communications equipment should be used no closer to any part of the QUATTRO® including cables, than the recommended separation distance calculated from the equation appropriate to the frequency of the transmitter. Recommend separation distance $d = 1.2 \sqrt{P}$ $d = 1.2 \sqrt{P}$ 80 MHz to 800 MHz $d = 2.3 \sqrt{P}$ 800 MHz to 2.5 GHz where P is the maximum output power rating of the transmitter in watts (W) according to the transmitter manufacturer and d is the recommended separation distance in meters (m). Field strengths from fixed RF transmitters as determined by an electromagnetic site survey, ^a should be less than the compliance level in each frequency range. ^b Interference may occur in the vicinity of equipment marked with the following symbol: 
Radiated RF IEC 61000-4-3	3 V/m 80 MHz ~ 2.5 GHz	3 V/m	

Note1: At 80 MHz and 800 MHz, the higher frequency range applies.

Note2: These guidelines may not apply in all situations. Electromagnetic propagation is affected by absorption and reflection from structures, objects, and people.

^a Field strengths from fixed transmitters, such as base stations for radio (cellular/ cordless) telephones and land mobile radio, AM and FM radio broadcast, and TV broadcast cannot be predicted theoretically with accuracy. To assess the electromagnetic environment due to fixed RF transmitters, an electromagnetic site survey should be considered. If the measured field strength in the location in which the QUATTRO® is used exceeds the applicable RF compliance level above, the QUATTRO® should be observed to verify normal operation. If abnormal performance is observed, additional measures may be necessary, such as reorienting or relocating the QUATTRO®.

^b Over the frequency range 150 kHz to 80MHz, field strengths should be less than 3 V/m.

Recommended Separation Distance Between Portable and Mobile RF Communications Equipment and the QUATTRO®			
Output Power of Transmitter in Watts (W)	Separation distance according to frequency of transmitter in Meters (m)		
	150 kHz to 80 MHz $d = 1.2 \sqrt{P}$	80 MHz to 800 MHz $d = 1.2 \sqrt{P}$	800 MHz to 2.5GHz $d = 2.3 \sqrt{P}$
0.01	0.01	0.01	0.01
0.12	0.12	0.12	0.12
0.12	0.12	0.12	0.12
0.23	0.23	0.23	0.23
0.1	0.1	0.1	0.1

For transmitters rated at a maximum output power not listed above, the recommended separation distance d in Meters (m) can be estimated using the equation applicable to the frequency of the transmitter, where P is the maximum output power rating of the transmitter in Watts (W) according to the transmitter manufacturer. Note: At 80MHz and 800MHz, the separation distance for the higher frequency range applies. Note: These guidelines may not apply in all situations. Electromagnetic propagation is affected by absorption and reflection from structures, objects, and people.

This medical device is compliant with:
 IEC 60601.1 3rd edition Medical electrical equipment safety and essential performance
 IEC 60601.1.11 2010 Home healthcare environment

USER MANUAL PART NUMBER 50-02-07-200/7



www.talleygroup.com



Talley Group Limited
 Premier Way, Abbey Park Industrial Estate
 Romsey, Hampshire, SO51 9DQ England
 TEL: +44(0)1794 503500
 FAX: +44(0)1794 503555
 EMAIL: sales@talleygroup.com

