

LOW NO<sub>x</sub> TURBOPOWER® • PACKAGED WATER HEATER  
**POLYSHIELD® POLYMER-LINED STORAGE TANK**  
**TANK SERIES 250 GALLONS VERTICAL**

MODEL NUMBER	Recovery gph ①		INPUT Btu/h	Min. Inlet Flow Gas Pressure " W.C. ②	SCAQMD Energy Model No.		Dimensions (inches)			Blower Motor		Shipping Weight #
	40° - 120°F	40° - 140°F			A	B	C	HP	Amps			
1000 P 250A-TPL	1000	800	800,000	4.5	8TPL	800 MBtu/h	33	8	1	1/2	7	1590
1500 P 250A-TPL	1500	1200	1,200,000	4.5	12TPL	1200 MBtu/h	50	8	1-1/4	1	14	1960

① Recoveries based on 83% thermal efficiency. ASHRAE 90.1 compliant for efficiency and standby loss.

② With standard gas train

③ 4" x 42" Channel skids for inputs ≤ 1000 MBtu/h.

4" x 53" Channel skids for inputs > 1000 MBtu/h.

\* The information presented is for natural gas 0.6 S.G.

Dimensions are in inches unless otherwise specified.

For standard and optional equipment, see form #PV 6453.

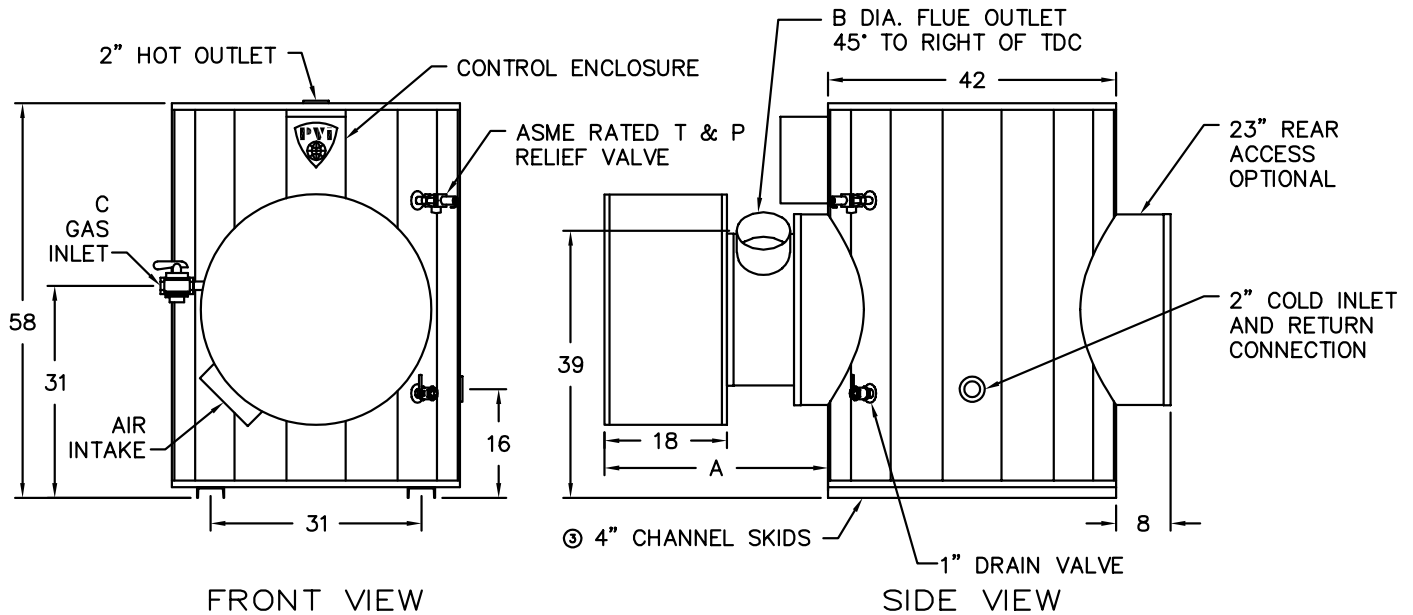

**STANDARD GAS PRESSURE REQUIREMENTS:**  
 SEE TABLE FOR MINIMUM PRESSURE BY MODEL.  
 MAXIMUM STATIC INLET GAS PRESSURE IS 10.5" W.C.  
 FOR GAS PRESSURES OUTSIDE OF THIS RANGE,  
 CONTACT YOUR PVI REPRESENTATIVE.

**VENTING REQUIREMENTS:**  
 -.02" TO -.06" W.C. (NEGATIVE PRESSURE).  
 TYPE B VENTING.  
**ENTIRE VENT SYSTEM SHOULD NEVER BE SIZED BASED UPON  
 THE VENT CONNECTION DIAMETER EXCLUSIVELY. CHECK  
 NATIONAL FUEL GAS CODE UNDER "FAN ASSISTED."**

**STANDARD ELECTRICAL REQUIREMENTS:**  
**VOLTAGE:** 120V, 1Ø, 60 HZ., 20 AMPS.  
 OTHER VOLTAGES REQUIRE AN EXTERNAL  
 STEPDOWN TRANSFORMER.

**PVI RESERVES THE RIGHT TO CHANGE THE DESIGN AND  
 SPECIFICATION WITHOUT NOTICE.**



PVI INDUSTRIES, LLC  
 FORT WORTH, TEXAS 76111  
 (800) 784-8326 • www.pvi.com

Product is patented in the U.S., Canada, and Mexico.

