

GRIPPER ACTUATOR

TYPES

GM 85 TO

GM 205



Dear Customer,

Congratulations on choosing a SCHUNK product. By choosing SCHUNK, you have opted for the highest precision, top quality and best service.

You are going to increase the process reliability of your production and achieve best machining results – to the customer's complete satisfaction.

SCHUNK products are inspiring.

Our detailed assembly and operation manual will support you.

Do you have further questions? You may contact us at any time – even after purchase. You can reach us directly at the mentioned addresses in the last chapter of these instructions.

Kindest Regards,

Your SCHUNK GmbH & Co. KG
Precision Workholding Systems
Bahnhofstr. 106 - 134
D-74348 Lauffen/ Neckar

Tel. +49-7133-103-2503
Fax +49-7133-103-2189
automation@de.schunk.com
www.schunk.com

Document last updated: 17.12.2009





Contents

1	SAFETY	3
1.1	SYMBOL KEY	3
1.2	APPROPRIATE USE	3
1.3	SAFETY NOTES.....	3
1.4	INDICATIONS TO THE OPERATING MANUAL	4
2	WARRANTY	4
3	SCOPE OF DELIVERY	5
4	TECHNICAL DATA	5
5	OPERATING AND ENVIRONMENTAL CONDITIONS	5
6	ASSEMBLY AND INSTALLATION	5
6.1	DESIGN PRECAUTIONS	5
6.2	COMPRESSED AIR SUPPLY.....	6
6.3	SPECIAL CONNECTING MEASURES.....	6
6.4	ASSEMBLY MEASURES.....	6
6.5	MEASURES FOR THE INITIAL OPERATION.....	7
7	HANDLING	7
7.1	GRIP FORCE SAFETY DEVICE GM 105 AND GM 205	7
7.2	DOUBLE PISTON AIR CONNECTOR	8
7.3	END POSITION INTERROGATION	8
8	REPAIRS	9
9	RESPONSE TO MALFUNCTIONS	9
10	MAINTENANCE AND CARE	10
11	REPLACEMENT PARTS	11
12	EC DECLARATION OF INCORPORATION	12
13	CONTACT	13

1 Safety

1.1 Symbol Key



You will find this symbol wherever **hazards for persons** or **damage to the product** are possible.



This symbol indicates **important information** on the product or its handling.

1.2 Appropriate Use

The unit must only be used within the scope of its technical data. Appropriate use also includes compliance with the conditions the manufacturer has specified for commissioning, assembly, operation, environment and maintenance. Using the unit with disregard to even a minor specification will be deemed inappropriate use. The manufacturer assumes no liability for any injury or damage resulting from inappropriate use.

The gripper actuators are manufactured in accordance with the current level of technology and with recognised safety regulations. During their use, however, there may occur risks to life and limb of the user or impairment of the portal actuator and other material assets.

The gripper actuators are intended exclusively for the parallel gripping of service loads in any position that do not react in their manipulation with any risk to persons, property or the environment.

The maximum permissible service loads and forces are given in our standard catalogue. Any usage beyond these definitions is inappropriate.

The manufacturer cannot be held liable for loss or damage arising therefrom. The risk is borne exclusively by the user.

The gripper actuator must only be operated by persons that are familiar therewith and that have been instructed in the associated hazards. The relevant accident prevention regulations and the other generally recognised safety and occupational health regulations must be complied with.

1.3 Safety Notes

- 1. Responsibility for the compatibility of pneumatic equipment lies with the person who designs the pneumatic system or takes the decision on its specifications.**
 - Since the products specified herein can be used under various operating conditions, their compatibility with the appropriate pneumatic system must be based on specifications and/or tests in order to conform to their requirements.
- 2. Machines and equipment operated by pneumatic means may only be used by**



trained personnel.

- Compressed air can be hazardous if an operator is not familiar with its use. The assembly, handling or repair of pneumatic systems is to be undertaken by trained and experienced personnel.

- 3. Do not carry out maintenance work on machines and equipment and do not attempt to remove components until it has been confirmed that it is safe to do so.**
 - Inspection and maintenance of machines and equipment may only be carried out after it has been confirmed that the devices that must be switched off are in a securely deactivated condition.
 - If machine parts must be removed, carry out safety precautions as mentioned above. Deactivate the compressed air supply to this machine and release any remaining compressed air from the system.
 - Before machines and equipment are switched on again, take measures to ensure that cylinder rods etc. are not pushed outwards. Allow compressed air to enter the system slowly so that counterpressure builds up gradually.
- 4. Contact SCHUNK (see chapter 13 page 13) if the product is to be used under one of the following conditions:**
 - Conditions and environments that lie outside the stated specifications, or where the product is to be used outdoors.
 - Installation in equipment in conjunction with nuclear power, railways, aerospace, vehicles, medical equipment, food and drink, leisure equipment, emergency shutdown circuits, applications in presses or safety equipment.
 - Any application that may possibly have negative influences on persons, animals or property and that requires a special safety analysis.
- 5. This user manual should always be easily accessible.**

1.4 Indications to the operating manual

This user manual describes gripper actuators of series GM 85, GM 105 and GM 205. All statements in this user manual refer to the types stated above.

2 Warranty

The warranty period is 24 months or 40 million load cycles after delivery date from the factory, assuming use in single-shift operation and that the recommended maintenance and lubrication

intervals are respected. Components that come into contact with workpieces, wearing parts, shock absorbers, stop screws and proximity switches are never included in the warranty. The warranty covers the replacement or repair of defective parts in the manufacturing plant. Further claims are hereby excluded. In this context, please also see our General Terms and Conditions.

3 Scope of Delivery

The scope of delivery comprises

- Gripper actuator GM, depending on the version ordered

4 Technical Data

Please consult our catalogue for further technical details. The last version is valid in each case. (in accordance with Chapter 2.3 General Terms and Conditions)

The airborne sound emitted from the unit is $\leq 70\text{dB(A)}$

5 Operating and environmental conditions

- Do not use the product in environments comprising corrosive gases, salt water, water or vapours.
- For use in an atmosphere where water drops, oil, sprays etc, occur take appropriate countermeasures in order to ensure protection.
- If electronic end switches are to be used, these should not be used in the presence of strong magnetic fields.
- Please contact SCHUNK (see chapter 13 page 13) if the product is to be used in the presence of strong magnetic fields.
- Do not use the gripper actuator in an atmosphere in which it could come into contact with fluids such as oil or water.
- Do not use the gripper actuator in an atmosphere in which it could come into direct contact with substances such as powder dust, dust, sprays etc.
- Do not use the gripper actuator in an atmosphere in which sources of heat are present.
- Do not subject the gripper actuator to excessive vibrations and/or shocks.

6 Assembly and Installation

6.1 Design precautions

- A protective guard is recommended in order to minimise the risk of injury.
- Ensure that loose, fixed and/or connected parts are tightened securely.
- Take account of the possibility that the operating pressure may decrease as a result of power failures etc.
- Pay attention to the possibility of the failure of power supplies.

- Mount the compressed air supply in such a way as to prevent a gripping action.
- Pay attention to emergency shutdown facilities.
- Pay attention to what will happen after an emergency stop or abnormal stoppage. Ensure that nobody can be placed at risk or be injured when equipment is restarted.

6.2 Compressed air supply

- Use clean compressed air and insert a filter between the supply and the pneumatic system.
- Install a water separator in the pneumatic system.
- Use the product only within the range specified for the medium temperature and ambient temperature.

Air specification

- dry (free from condensation)
- filtered to 10 microns
- oiled or oil-free

6.3 Special connecting measures

- Use connecting pipes of a cross-section that is larger than or identical to that of the connector thread.
- Blow air through the connecting pipes before fitting the devices in order to remove any dust, contaminant or particles.
- Avoid the ingress of sealing material into the pipe network.
- Do not remove pneumatic components from their packaging until shortly before fitting.

6.4 Assembly measures

- During the mounting of the gripper actuator or gripper jaws on the gripper actuator, do not allow the system to be subjected to impermissible forces or moments.
- The flatness of the mounting surfaces must be less than 0.02mm.
- Select the correct means of connection with a load that has its own guidance mechanism and ensure that this is adequately aligned.
- Avoid contact with the gripper actuator during operation.
- Select a suitable screw tightening torque for mounting of the gripper actuator or loads on the gripper actuator in accordance with the generally valid guidelines for screw connections.

6.5 Measures for the initial operation



Please read this user manual carefully. Knowledge of this user manual is essential in order to prevent errors and ensure problem-free operation.



Under no circumstances may gripper actuators be operated with oiled air if they are subsequently to be operated with oil-free air.

- Check the technical specifications.
- Do not use the device until you have checked that it functions correctly taking account of all permissible operating parameters.
- Regulate the operating speed of the cylinder by means of throttle type non-return valves. Increase from the low speed to higher speeds until the required operating speed is reached.

Selection and dimensioning

- Do not subject the units to loads that exceed the limits of their operating range. If excessive loads are applied, the gripper jaw guidance system and closing mechanism could suffer damage or inaccuracies. The maximum permissible loads are given in our standard catalogue.
- Do not allow the system to experience impermissible forces or shocks and do not use excessively long gripper jaws. The maximum permissible gripper jaw length is given in our standard catalogue.

7 Handling

7.1 Grip force safety device GM 105 and GM 205

In order to secure the grip force in the event of pressure loss, a spring (Pos. 16 at Figure 1) can be integrated with the need for further accessories. Depending on which side the spring is installed, the grip force safety device operates in a clamping or expanding direction.

If a gripper actuator including a grip force safety device as described in our standard catalogue is ordered, it is supplied with the spring already installed by SCHUNK.

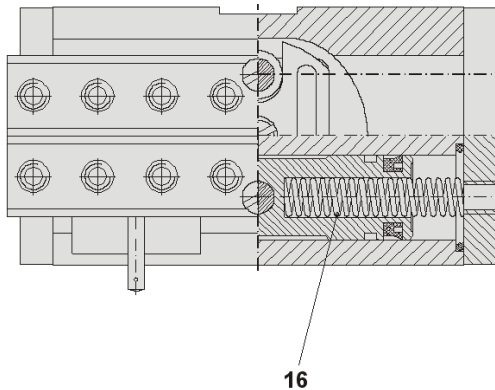

Figure 1: grip force safety device

7.2 Double piston air connector

The grip forces given in our standard catalogue are valid when both pistons are subjected to pressure of 6 bar. If only the one piston is connected, the grip force can be halved.

If both pistons are connected, it must be ensured that the pistons are connected in a crosswise manner so that the pistons move in an opposing direction.

7.3 End position interrogation

Standardised interrogation sets for direct mounting are available for interrogation of end positions.

Proximity switch - complete GMNS-...

The scope of delivery includes:

- 1x retaining plate
- 1x proximity switch
- 1x connection cable

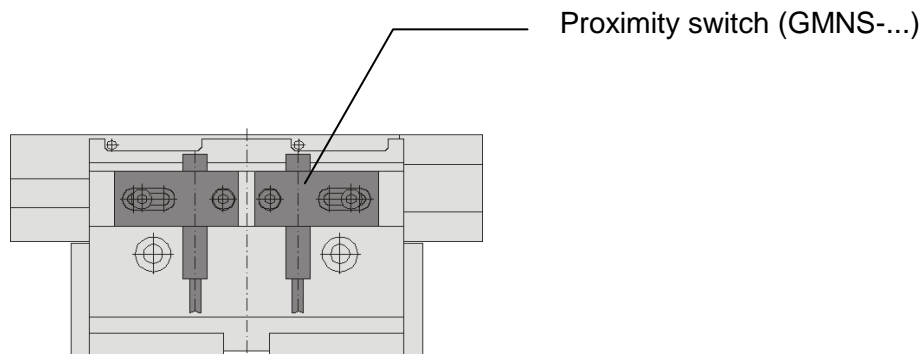

Figure 2: position from the proximity switch

After the clamping screw has been loosened, the proximity switch can be set by means of the retaining plate. Interrogation is carried out directly on the switching pin integrated in the gripper jaw. The interrogation set can be installed on both sides of the actuator, so that both end positions can be interrogated.

8 Repairs



The repair or elimination of defects on our products by the customer may only be carried out with our explicit written agreement. Any failure to adhere to this principle renders invalid our warranty and liability for any resulting warranty or secondary losses.

Following receipt and examination, all gripper actuators of series GM can be repaired by SCHUNK.

9 Response to malfunctions



Malfunctions that are caused by defective components may only be remedied by replacement of these components.

Defective components may only be replaced by SCHUNK genuine replacement parts.

Malfunction	Cause	Remedy
-------------	-------	--------

Malfunction	Cause	Remedy
Gripper actuator does not open/close	(1) No compressed air (2) Incorrect pneumatic connections	(1) Check compressed air (2) Check pneumatic elements
End position signal not present	(1) Initiator incorrectly set in relation to stop (2) Initiator defective (3) Broken cable	(1) Readjust initiator (2) Replace initiator (3) Replace initiator cable
Hard gripping of workpiece	(1) Ventilation valve defective (2) Stroke speed too high	(1) Change ventilation valve (2) Set ventilation valve
Gripper cannot grip part or loses grip on part	(1) Workpiece mass too high (2) Gripper jaws too long (3) Design not optimum	(1) Use larger gripper actuator (2) Move gripping point further inwards (3) Adapt design use physical lock gripping

10 Maintenance and Care



Under no circumstances may gripper actuators be operated with oiled air if they are subsequently to be operated with oil-free air.

- The integral cylinders are lubricated for life and do not require relubrication. Operation with oiled or oil-free compressed air is permissible without restrictions.
- The complete mechanism is already lubricated. It is not therefore necessary to lubricate this again before operation.
Lubrication or relubrication of the mechanism with rolling bearing grease is recommended after approx. 4 million cycles.
- All gripper actuators of series GM are maintenance-free. In order to achieve the maximum operating life, this chapter and chapter 6.2 (at page 6) of this user manual should be observed.
- Apart from normal cleaning of machines, no further maintenance measures are necessary.

11 Replacement parts

As standardised wear part sets, seal sets are available. The scope of delivery includes all seals. Ordering numbers of the seal sets:

- GMDI 085 (for gripper actuator GM 85)
- GMDI 105 (for gripper actuator GM 105)
- GMDI 205 (for gripper actuator GM 205)

In accordance with the section drawing below, all other wear parts and individual parts are available as single items.

Ordering numbers are as indicated in the following example

- Part No. 1 GM 105-01

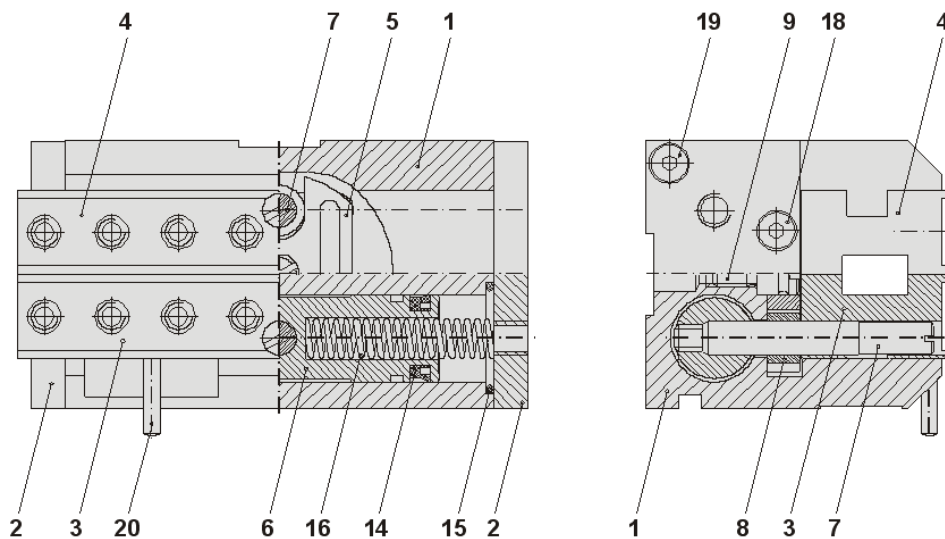

Figure 3: section drawing GM 85, 105, 205

12 EC declaration of incorporation

In terms of the EC Machinery Directive 2006/42/EC, annex II B

Manufacturer/
distributor SCHUNK GmbH & Co. KG.
 Spann- und Greiftechnik
 Bahnhofstr. 106 – 134
 74348 Lauffen/Neckar, Germany

We hereby declare that the following product:

Product designation 2-Finger Parallel Gripper, long stroke
Type designation: GM 85...GM 205
ID number: 0313066...0313086

meets the applicable basic requirements of the Directive **Machinery (2006/42/EC)**.

The incomplete machine may not be put into operation until conformity of the machine into which the incomplete machine is to be installed with the provisions of the Machinery Directive (2006/42/EC) is confirmed.

Applied harmonized standards, especially:

EN ISO 12100-1 Safety of machines - Basic concepts, general principles for design -- Part 1:
 Basic terminology, methodology
EN ISO 12100-2 Safety of machines - Basic concepts, general principles for design -- Part 2:
 Technical principles

The manufacturer agrees to forward on demand the special technical documents for the incomplete machine to state offices.

The special technical documents according to Annex VII, Part B, belonging to the incomplete machine have been created.

Person responsible for documentation: Mr. Michael Eckert, Tel.: +49(0)7133/103-2204

Location, date/signature: Lauffen, Germany,
 January 2010

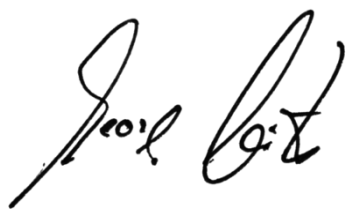
p.p. 

Title of the signatory Director for Development

13 Contact



GERMANY – HEAD OFFICE

SCHUNK GmbH & Co. KG
Spann- und Greiftechnik
Bahnhofstrasse 106 – 134
D-Lauffen/Neckar
Tel. +49-7133-103-0
Fax +49-7133-103-2399
info@de.schunk.com
www.schunk.com



CANADA

SCHUNK Intec Corp.
190 Britannia Road East,
Units 23-24
Mississauga, ON L4Z 1W6
Tel. +1-905-712-2200
Fax +1-905-712-2210
info@ca.schunk.com
www.ca.schunk.com



DENMARK

SCHUNK Intec A/S
Storhaven 7
7100 Vejle
Tel. +45-43601339
Fax +45-43601492
info@dk.schunk.com
www.dk.schunk.com



HUNGARY

SCHUNK Intec Kft.
Széchenyi út. 70.
3530 Miskolc
Tel. +36-46-50900-7
Fax +36-46-50900-6
info@hu.schunk.com
www.hu.schunk.com



AUSTRIA

SCHUNK Intec GmbH
Holzbauernstr. 20
4050 Traun
Tel. +43-7229-65770-0
Fax +43-7229-65770-14
info@at.schunk.com
www.at.schunk.com



CHINA

SCHUNK GmbH & Co.KG
Shanghai
Representative Office
777 Zhao Jia Bang Road
Pine City Hotel, Room 923
Xuhui District
Shanghai 200032
Tel. +86-21-64433177
Fax +86-21-64431922
info@cn.schunk.com
www.cn.schunk.com



FRANCE

SCHUNK Intec SARL
Parc d'Activités des Trois
Noyers 15, Avenue James de
Rothschild
Ferrières-en-Brie
77614 Marne-la-Vallée
Cedex 3
Tel. +33-1-64 66 38 24
Fax +33-1-64 66 38 23
info@fr.schunk.com
www.fr.schunk.com



INDIA

SCHUNK India Branch Office
80 B, Yeswanthpur
Industrial Suburbs,
Bangalore 560 022
Tel. +91-80-41277361
Fax +91-80-41277363
info@in.schunk.com
www.in.schunk.com



BELGIUM, LUXEMBOURG

SCHUNK Intec N.V./S.A.
Bedrijvencentrum Regio Aalst
Industrielaan 4, Zuid III
9320 Aalst-Erembodegem
Tel. +32-53-853504
Fax +32-53-836022
info@be.schunk.com
www.be.schunk.com



CZECH REPUBLIC

SCHUNK Intec s.r.o.
Ernsta Macha 1
643 00 Brno
Tel. +420-545 229 095
Fax +420-545 220 508
info@cz.schunk.com
www.cz.schunk.com



GREAT BRITAIN, IRELAND

SCHUNK Intec Ltd.
Cromwell Business Centre
10 Howard Way,
Interchange Park
Newport Pagnell MK16 9QS
Tel. +44-1908-611127
Fax +44-1908-615525
info@gb.schunk.com
www.gb.schunk.com



ITALY

SCHUNK Intec S.r.l.
Via Barozzo
22075 Lurate Caccivio (CO)
Tel. +39-031-4951311
Fax +39-031-4951301
info@it.schunk.com
www.it.schunk.com

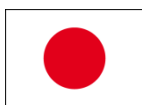

JAPAN

SCHUNK Intec K.K.
45-28 3-Chome Sanno
Ohta-Ku Tokyo 143-0023
Tel. +81-33-7743731
Fax +81-33-7766500
s-takano@tbk-hand.co.jp
www.tbk-hand.co.jp



POLAND

SCHUNK Intec Sp.z o.o.
Stara Iwiczna,
ul. Słoneczna 116 A
05-500 Piaseczno
Tel. +48-22-7262500
Fax +48-22-7262525
info@pl.schunk.com
www.pl.schunk.com



SOUTH KOREA

SCHUNK Intec Korea Ltd.
907 Joongang
Induspia 2 Bldg.,
144-5 Sangdaewon-dong
Jungwon-gu, Seongnam-si
Kyunggi-do, 462-722
Tel. +82-31-7376141
Fax +82-31-7376142
info@kr.schunk.com
www.kr.schunk.com



**SWITZERLAND,
LIECHTENSTEIN**

SCHUNK Intec AG
Soodring 19
8134 Adliswil 2
Tel. +41-44-7102171
Fax +41-44-7102279
info@ch.schunk.com
www.ch.schunk.com



MEXICO, VENEZUELA

SCHUNK Intec S.A. de C.V.
Av. Luis Vega y Monroy # 332
Fracc. Plazas de Sol
Santiago de Querétaro,
Qro. 76099
Tel. +52-442-223-6525
Fax +52-442-223-7665
info@mx.schunk.com
www.mx.schunk.com



PORTUGAL

Sales Representative
Victor Marques
Tel. +34-937-556 020
Fax +34-937-908 692
Mobil +351-963-786 445
info@pt.schunk.com
www.pt.schunk.com



SPAIN

SCHUNK Intec S.L.
Foneria, 27
08304 Mataró (Barcelona)
Tel. +34-937 556 020
Fax +34-937 908 692
info@es.schunk.com
www.es.schunk.com



TURKEY

SCHUNK Intec
Bağlama Sistemleri ve
Otomasyon San. ve Tic. Ltd.
Şti.
Küçükyalı İş Merkezi
Girne Mahallesi
Irmak Sodak, A Blok, No: 9
34852 Maltepe, Istanbul
Tel. +90-216-366-2111
Fax +90-216-366-2277
info@tr.schunk.com
www.tr.schunk.com



NETHERLANDS

SCHUNK Intec B.V.
Speldenmakerstraat 3d
5232 BH 's-Hertogenbosch
Tel. +31-73-6441779
Fax +31-73-6448025
info@nl.schunk.com
www.nl.schunk.com



SLOVAKIA

SCHUNK Intec s.r.o.
Mostná 62
919 01 Nitra
Tel. +421-37-3260610
Fax +421-37-6421906
info@sk.schunk.com
www.sk.schunk.com



SWEDEN

SCHUNK Intec AB
Morabergsvägen 28
152 42 Södertälje
Tel. +46-8 554 421 00
Fax +46-8 554 421 01
info@se.schunk.com
www.se.schunk.com



USA

SCHUNK Intec Inc.
211 Kitty Hawk Drive
Morrisville, NC 27560
Tel. +1-919-572-2705
Fax +1-919-572-2818
info@us.schunk.com
www.us.schunk.com