

DA-AA

Analog audio distribution amplifier

User manual

Rev. 6

Nevion Support

Nevion Europe

P.O. Box 1020
3204 Sandefjord, Norway
Support phone 1: +47 33 48 99 97
Support phone 2: +47 90 60 99 99

Nevion USA

1600 Emerson Avenue
Oxnard, CA 93033, USA
Toll free North America: (866) 515-0811
Outside North America: +1 (805) 247-8560

E-mail: support@nevision.com

See <http://www.nevision.com/support/> for service hours for customer support globally.

Revision history

Current revision of this document is the uppermost in the table below.

| Rev. | Repl. | Date | Sign | Change description |
|------|-------|------------|--------|--|
| 6 | 5 | 2011-03-02 | AA/AJM | New template. Updated Materials declaration and Declaration of Conformity. Changed max input, added IMD and frq. response. |
| 5 | 4 | 2008-01-31 | | Added Declaration of Conformity. |
| 4 | 3 | 2007-10-26 | | New front page and removed old logo. |
| 3 | 2 | 2007-10-05 | | Added Materials Declaration and EFUP |
| 2 | 1 | 2005-07-29 | | Corrected description of connector module. |
| 1 | 0 | 2004-11-10 | | Changed page 8, output settings |
| 0 | A | 2004-05-25 | | Exchanged ANA1 and ANA2 on dip setting |
| A | - | 2003-10-21 | | Preliminary version |

Contents

- Revision history 2
- 1 General 4
- 2 Specifications 5
- 3 Configuration setup 6
- 4 Output configuration 8
 - 4.1 Configuration of ANA1 output 8
 - 4.2 Configuration of ANA2 outputs 8
- 5 Connector module 10
 - 5.1 Mounting the connector module 11
- 6 Module status 12
 - 6.1 Front panel – status monitoring 12
- 7 Interface with GYDA and RS-422 command set 13
 - 7.1 DA-AA Command table 13
- General environmental requirements for Neviaon equipment 14
- Product Warranty 15
- Appendix A Materials declaration and recycling information 16
 - A.1 Materials declaration 16
 - A.2 Recycling information 16
- EC Declaration of Conformity 17

1 General

The DA-AA is a dual 4 output analogue Audio Distributor. The DA-AA can be configured as either a dual 1x4 or a single 1x8 amplifier. The latter configuration is made by connecting the inputs in parallel or using DIP switch on PCB. The Distribution amplifier has differential inputs and differential outputs. Overall gain can be set by DIP switches or by potentiometer for high precision gain setting. The gain range setting is from -12 to +12 dB. The input signal can be mixed to the other channel using a DIP switch. The Distribution Amplifier handles analogue audio signals from 20Hz to 80 kHz. The DA-AA is designed for all audio distribution purposes in studio, duplication and Broadcast applications.

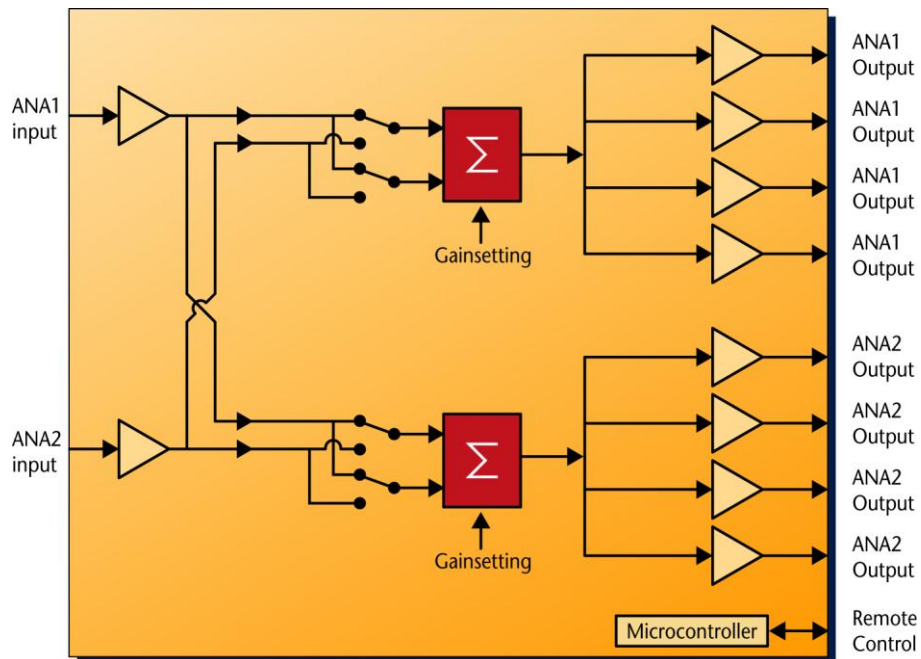

Figure 1 - DA-AA analogue audio distribution amplifier

2 Specifications

Electrical Input:

| | |
|------------------------|---------------|
| Number of inputs: | 2 |
| Connector: | DB15 balanced |
| Impedance: | > 10k ohms |
| Maximum Input Level: | +28 dBu |
| Common mode rejection: | >70dB |

Electrical Output:

| | |
|-------------------------------|---|
| Number of outputs: | 8 |
| Connector: | DB25 balanced (Tascam DA88) |
| Frequency response: | 50 Hz - 20 kHz \pm 0.05dB 20 Hz - 20 kHz \pm 0.1dB 20 Hz - 80 kHz \pm 0.2dB |
| Crosstalk: | -100 dB |
| THD+N: | > 100dB ref to 20 Hz-20 kHz @ 20dBu |
| IMD: | > 0.002% @ 18dBu |
| Impedance: | 40 ohms nominal. Maximum 55 ohms |
| Maximum Output Level: | +25 dBu |
| Output voltage balance ratio: | >30dB |
| Output common mode rejection: | >50dB |
| Switched gain tolerance: | 0.1dB |
| Gain: | -12 to +12 dB |

Features

High quality audio distribution.

- Configurable dual 1x4 or single 1x8 distribution amplifier.
- Left/right swapping capability
- Gain setting for professional and consumer equipment.
- DIP switch gain compensation 10kohms / 600 ohms load
- Precision gain adjustment
- High common mode rejection on both inputs and outputs.
- Inputs and outputs may be used with unbalanced equipment.
- The input signal can be mixed to the other channel or vice versa.

Control Interfaces

Card edge LEDs for voltage monitoring, RS-422 with open protocol, SNMP Agent and WEB interface with GYDA controller. Control system for access to setup and module status with BITE (Built-In Test Equipment) for use with GYDA Control System

Electrical

| | |
|--------|----------------------------------|
| Power: | +5V / 0.1 W, \pm 15V / 1.9W |
|--------|----------------------------------|

3 Configuration setup

The DA-AA has two channels, ANA1 and ANA2. DIP switch 1 (ANA1) and 2 (ANA2) sets the individual channel properties according to table:











































































































































| 1 | 8 |  Don't Care  On  Off |
|---|---|---|
|         |         | -12.5dB |
|         |         | -11.5dB |
|         |         | -10.9dB |
|         |         | -9.9dB |
|         |         | -6.0dB |
|         |         | -4.2dB |
|         |         | -2.7dB |
|         |         | 0.0dB |
|         | | +2.7dB |
| | | +4.2dB |
| | | +6.0dB |
| | | +9.9dB |
| | | +10.9dB |
| | | +11.5dB |
| | | +12.5dB |

Figure 2

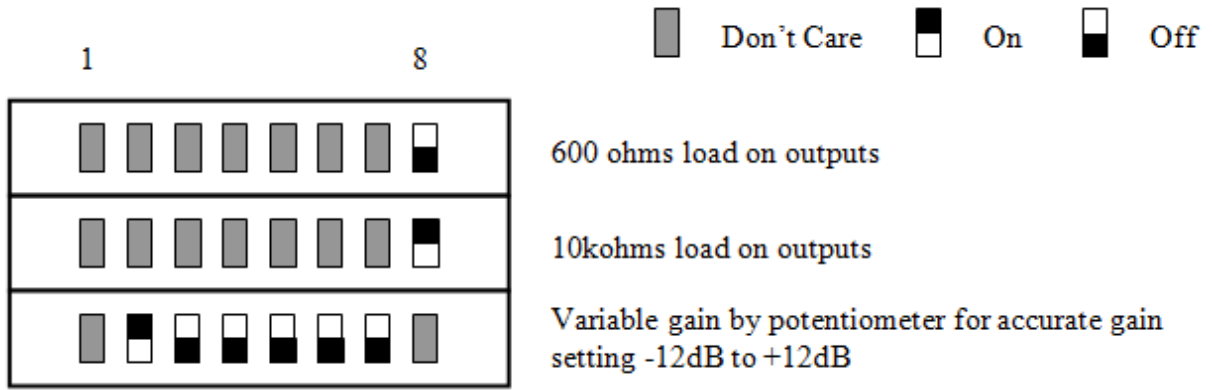

Figure 3

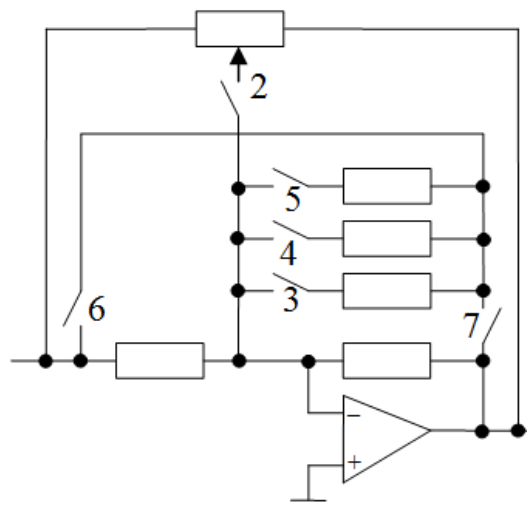

Figure 4 - Circuit diagram for advanced users

4 Output configuration

There are two groups of four outputs, ANA1 and ANA2 output. The two groups are individually configured using DIP switch 3 and DIP switch 4. The switch sets which of the input that is connected to the output.

4.1 Configuration of ANA1 output

Use dip switch SW4 / ANA1 for setting the outputs ANA1.

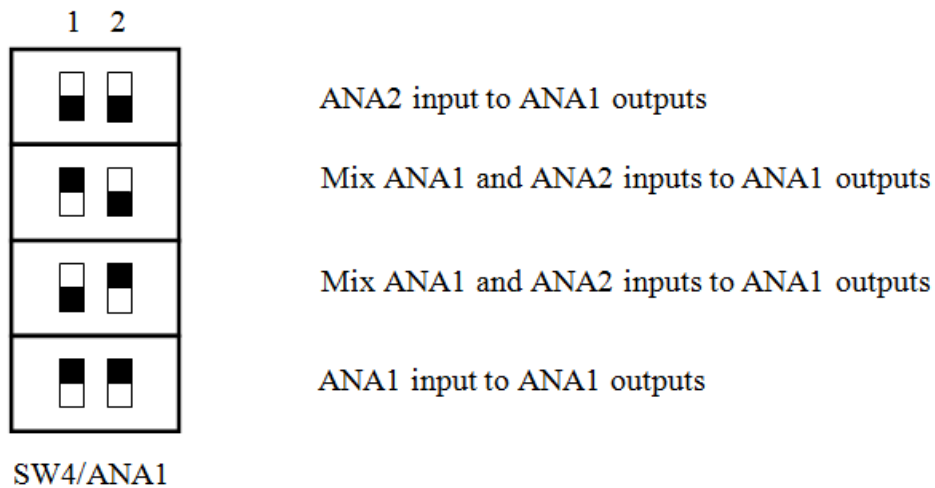

Figure 5

4.2 Configuration of ANA2 outputs

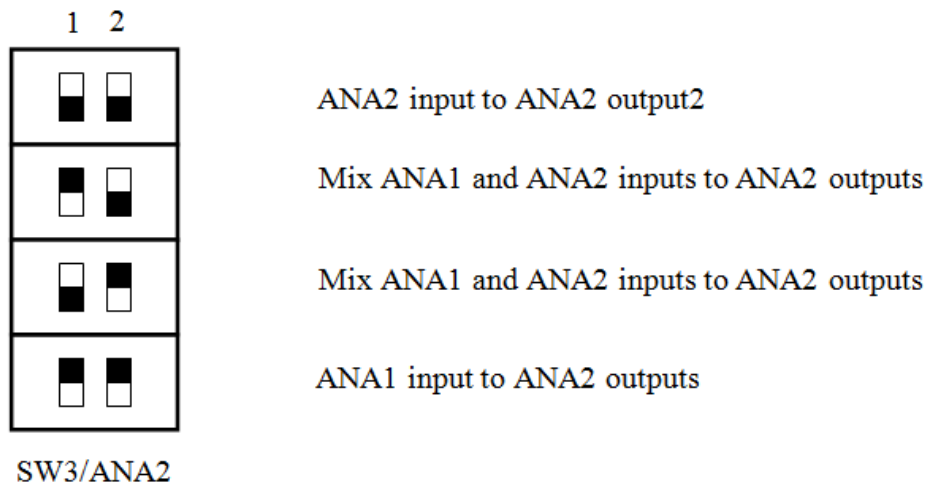

Figure 6

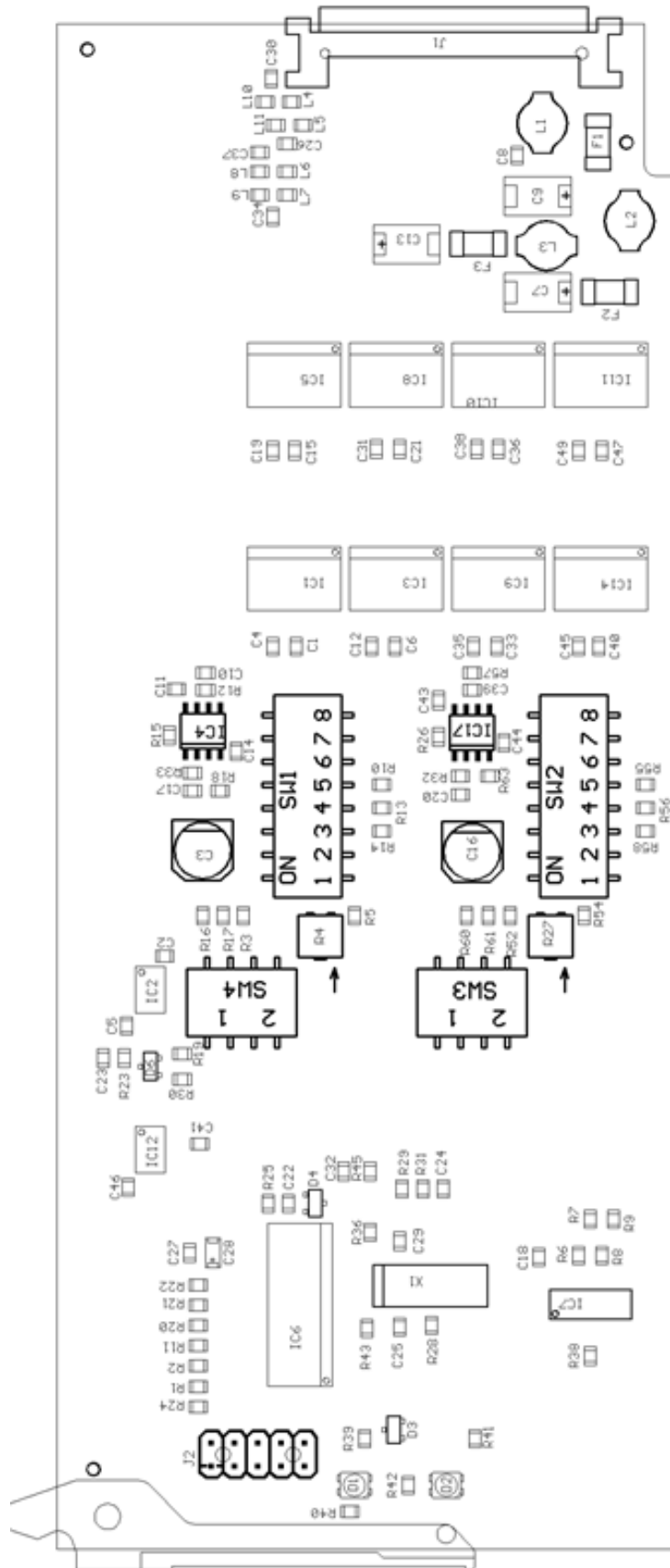

Figure 7 - DA-AA board layout

5 Connector module

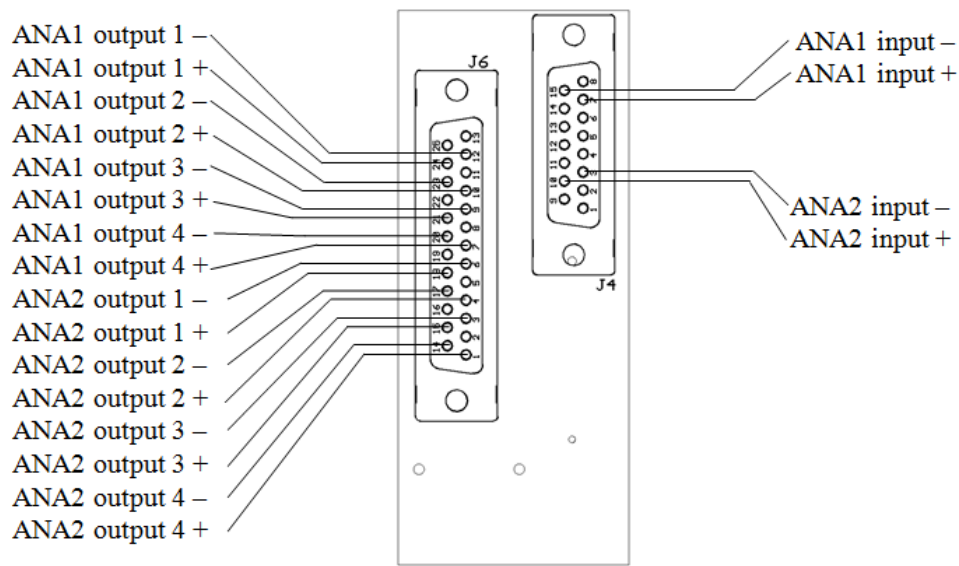

Figure 8 - Overview of the ADC-AES-C1 connector module

The DA-AA has a dedicated connector module: ADC-AES-C1. This module is mounted at the rear of the sub-rack. The module is shown in figure 6. J4 is the input DSUB connector, while J6 is the output connector. Both connectors are FEMALE.

Table 1 – J4

| Function | Pin |
|--|-------------|
| Analogue Audio ANA1 positive input (ANA1+) | 7 |
| Analogue Audio ANA1 negative input (ANA1-) | 15 |
| Analogue Audio ANA2 positive input (ANA2+) | 10 |
| Analogue Audio ANA2 negative input (ANA2-) | 3 |
| Ground | 2, 5, 8, 11 |

Table 2 - J6

| Function | Pin |
|---------------------------------------|---------------------------|
| Analogue Audio ANA1 positive output 1 | 24 |
| Analogue Audio ANA1 negative output 1 | 12 |
| Analogue Audio ANA1 positive output 2 | 10 |
| Analogue Audio ANA1 negative output 2 | 23 |
| Analogue Audio ANA1 positive output 3 | 21 |
| Analogue Audio ANA1 negative output 3 | 9 |
| Analogue Audio ANA1 positive output 4 | 7 |
| Analogue Audio ANA1 negative output 4 | 20 |
| Analogue Audio ANA2 positive output 1 | 18 |
| Analogue Audio ANA2 negative output 1 | 6 |
| Analogue Audio ANA2 positive output 2 | 4 |
| Analogue Audio ANA2 negative output 2 | 17 |
| Analogue Audio ANA2 positive output 3 | 15 |
| Analogue Audio ANA2 negative output 3 | 3 |
| Analogue Audio ANA2 positive output 4 | 1 |
| Analogue Audio ANA2 negative output 4 | 14 |
| Ground | 2, 5, 8, 11,16,19, 22, 25 |

5.1 Mounting the connector module.

The details of how the connector module is mounted, is found in the user manual for the sub-rack frame FR-2RU-10-2.

This manual is also available from our web site: <http://www.nevion.com/>

6 Module status

The status of the module can be monitored in three ways.

1. GYDA System Controller (optional).
2. LEDs at the front of the sub-rack.

LEDs are mounted on the module itself, whereas the GYDA System Controller is a separate module giving detailed information on the card status. The functions of the LEDs are described in sections 5.1. The GYDA controller is described in a separate user manual

6.1 Front panel – status monitoring

The status of the module can be easily monitored visually by the LED's at the front of the module. The LED's are visible through the front panel. The LED on top tells if the DA-AA is ok or not (green LED means ok – red is alarm). The second LED gives the input signal status.

The DA-AA has 2 LEDs each showing a status corresponding.

Table 3

| Diode \ state | Red LED | Yellow LED | Green LED | No light |
|---------------|-------------------|------------|------------------------------------|---------------------|
| Status | Module is faulty | | Module is OK Module power is OK | Module has no power |
| Input | No signal present | | Signal present | |

7 Interface with GYDA and RS-422 command set

All commands follow the Flashlink protocol and can be used for direct control access to the module. The control system can either be a GYDA-SC or a third-party control system with integrated Flashlink protocol. The module can also be manually controlled with a VT100 compatible terminal program.

The protocol can be found on our web page: <http://www.nevion.com>

7.1 DA-AA Command table

Table 4

| Command | Response | Comment |
|---------|---------------------------------|---------------------|
| ? | <i>See protocol description</i> | The "hello" command |
| Info | Module status information | |
| Status | Give module status | |

General environmental requirements for Nevion equipment

1. The equipment will meet the guaranteed performance specification under the following environmental conditions:
 - Operating room temperature range: 0°C to 40°C
 - Operating relative humidity range: <90% (non-condensing)

2. The equipment will operate without damage under the following environmental conditions:
 - Temperature range: -10°C to 50°C
 - Relative humidity range: <95% (non-condensing)

Product Warranty

The warranty terms and conditions for the product(s) covered by this manual follow the General Sales Conditions by Nevion, which are available on the company web site:

www.nevion.com

Appendix A Materials declaration and recycling information

A.1 Materials declaration

For product sold into China after 1st March 2007, we comply with the “Administrative Measure on the Control of Pollution by Electronic Information Products”. In the first stage of this legislation, content of six hazardous materials has to be declared. The table below shows the required information.

| 組成名稱 Part Name | Toxic or hazardous substances and elements | | | | | |
|---|--|----------------------|----------------------|---|--|--|
| | 鉛 Lead (Pb) | 汞 Mercury (Hg) | 鎘 Cadmium (Cd) | 六价铬 Hexavalent Chromium (Cr(VI)) | 多溴联苯 Polybrominated biphenyls (PBB) | 多溴二苯醚 Polybrominated diphenyl ethers (PBDE) |
| DA-AA | ○ | ○ | ○ | ○ | ○ | ○ |
| <p>O: Indicates that this toxic or hazardous substance contained in all of the homogeneous materials for this part is below the limit requirement in SJ/T11363-2006.</p> <p>X: Indicates that this toxic or hazardous substance contained in at least one of the homogeneous materials used for this part is above the limit requirement in SJ/T11363-2006.</p> | | | | | | |

This is indicated by the product marking:



A.2 Recycling information

Nevion provides assistance to customers and recyclers through our web site <http://www.nevion.com/>. Please contact Nevion's Customer Support for assistance with recycling if this site does not show the information you require.

Where it is not possible to return the product to Nevion or its agents for recycling, the following general information may be of assistance:

- Before attempting disassembly, ensure the product is completely disconnected from power and signal connections.
- All major parts are marked or labeled to show their material content.
- Depending on the date of manufacture, this product may contain lead in solder.
- Some circuit boards may contain battery-backed memory devices.

EC Declaration of Conformity



| | | |
|---|---|-----------------------|
| MANUFACTURER | Nevion Europe AS P.O. Box 1020, 3204 Sandefjord, Norway | |
| AUTHORIZED REPRESENTATIVE (Established within the EEA) | Not applicable | |
| MODEL NUMBER(S) | DA-AA | |
| DESCRIPTION | Analogue Audio Distribution Amplifier | |
| DIRECTIVES this equipment complies with | Low voltage (EU Directive 2006/95/EC) EMC (EU Directive 2004/108/EC) RoHS (EU Directive 2002/95/EC) China RoHS ¹ WEEE (EU Directive 2002/96/EC) REACH | |
| HARMONISED STANDARDS applied in order to verify compliance with Directive(s) | EN 55103-1:1996 EN 55103-2:1996 | |
| TEST REPORTS ISSUED BY | Notified/Competent Body | Report no: |
| | Nemko | E07379.00 |
| TECHNICAL CONSTRUCTION FILE NO | Not applicable | |
| YEAR WHICH THE CE-MARK WAS AFFIXED | 2008 | |
| TEST AUTHORIZED SIGNATORY | | |
| MANUFACTURER | AUTHORIZED REPRESENTATIVE (Established within EEA) | Date of Issue |
| | | 2008-07-24 |
| | | Place of Issue |
| | Not applicable | Sandefjord, Norway |
| Name |  NEVION EUROPE AS O.nr. 976 584 201 MVA | |
| Position | Thomas Øhrbom VP of Quality, Nevion (authorized signature) | |

¹ Administration on the Control of Pollution Caused by Electronic Information Products