

Dear Valued Customer,

Thank you for purchasing Patton Electronics products! We do appreciate your business. I trust that you find this user manual helpful.

We manufacture one of the widest selections of data communications products in the world including CSU/DSU's, network termination units, powered and self-powered short range modems, fiber optic modems, interface converters, baluns, electronic data switches, data-line surge protectors, multiplexers, transceivers, hubs, print servers and much more. We produce these products at our Gaithersburg, MD, USA, facility, and can custom manufacture products for your unique needs.

We would like to hear from you. Please contact us in any of the following ways to tell us how you like this product and how we can meet your product needs today and in the future.

Web: <http://www.patton.com>  
Sales E-mail: [sales@patton.com](mailto:sales@patton.com)  
Support E-mail: [support@patton.com](mailto:support@patton.com)  
Phone - Sales (301) 975-1000  
Phone - Support (301) 975-1007  
Fax: (301) 869-9293  
Mail: Patton Electronics Company  
7622 Rickenbacker Drive  
Gaithersburg, MD 20879 USA

We are committed to a quality product at a quality price. Patton Electronics is BABT and ISO 9001 certified. We meet and exceed the highest standards in the industry (CE, UL, etc.).

It is our business to serve you. If you are not satisfied with any aspect of this product or the service provided from Patton Electronics or its distributors, please let us know.

Thank you.

Burton A. Patton  
Vice President

P.S. Please tell us where you purchased this product.

---

---

---

---

---

# USER MANUAL

## MODEL 2020RC Miniature RS-232 to V.35 Interface Converter: Rack Mount Card



**PE PATTON**  
**Electronics Co.**



An ISO-9001  
Certified Company

Part# 07M2020RC-B  
Doc# 077121UB  
Revised 1/16/97

SALES OFFICE  
(301) 975-1000  
TECHNICAL SUPPORT  
(301) 975-1007  
<http://www.patton.com>

## 1.0 WARRANTY INFORMATION

**Patton Electronics** warrants all Model 2020RC components to be free from defects, and will—at our option—repair or replace the product should it fail within one year from the first date of shipment.

This warranty is limited to defects in workmanship or materials, and does not cover customer damage, abuse or unauthorized modification. If this product fails or does not perform as warranted, your sole recourse shall be repair or replacement as described above. Under no condition shall **Patton Electronics** be liable for any damages incurred by the use of this product. These damages include, but are not limited to, the following: lost profits, lost savings and incidental or consequential damages arising from the use of or inability to use this product. **Patton Electronics** specifically disclaims all other warranties, expressed or implied, and the installation or use of this product shall be deemed an acceptance of these terms by the user.

### 1.1 RADIO AND TV INTERFERENCE

The Model 2020RC generates and uses radio frequency energy, and if not installed and used properly—that is, in strict accordance with the manufacturer's instructions—may cause interference to radio and television reception. The Model 2020RC has been tested and found to comply with the limits for a Class A computing device in accordance with the specifications in Subpart J of Part 15 of FCC rules, which are designed to provide reasonable protection from such interference in a commercial installation. However, there is no guarantee that interference will not occur in a particular installation.

If the Model 2020RC does cause interference to radio or television reception, which can be determined by turning the power off or disconnecting the unit, the user is encouraged to try to correct the interference by one of the following measures: moving the computing equipment away from the receiver, re-orienting the receiving antenna, and/or plugging the receiving equipment into a different AC outlet (such that the computing equipment and receiver are on different branches).

If the user detects intermittent or continuous product malfunction due to nearby high power transmitting radio frequency equipment, the user is advised to use data cables with an external outer shield bonded to a metal or metalized connector, and to configure the rear card as shown in Section 3.2 of this manual.

## 1.2 SERVICE

All warranty and non-warranty repairs must be returned freight prepaid and insured to Patton Electronics. All returns must have a Return Materials Authorization number on the outside of the shipping container. This number may be obtained from Patton Electronics Technical Service at **(301) 975-1007**; **<http://www.patton.com>**; or **[support@patton.com](mailto:support@patton.com)**. *Packages received without an RMA number will not be accepted.*

Patton Electronics' technical staff is also available to answer any questions that might arise concerning the installation or use of your Model 2020RC. Technical Service hours: **8AM to 5PM EST, Monday through Friday.**

## 1.3 CE NOTICE

The CE symbol on your Patton Electronics equipment indicates that it is in compliance with the Electromagnetic Compatibility (EMC) directive and the Low Voltage Directive (LVD) of the Union European (EU). A Certificate of Compliance is available by contacting Technical Support.

## 2.0 GENERAL INFORMATION

Thank you for your purchase of this Patton Electronics product. This product has been thoroughly inspected and tested and is warranted for One Year parts and labor. If any questions or problems arise during installation or use of this product, please do not hesitate to contact Patton Electronics Technical Support at (301) 975-1007.

### 2.1 FEATURES

- Synchronous operation, full or half duplex
- Allows an RS-232 DCE to communicate bi-directionally with a V.35 DTE
- Allows an RS-232 DTE to communicate bi-directionally with a V.35 DCE
- Data rates up to **384 kbps**
- DCE/DTE strap selectable
- Front panel LED indicators monitor seven parameters
- Dual UD-26 Connectors on rear card
- Fits in Patton's rack chassis and Cluster Boxes
- Made in the USA

### 2.2 DESCRIPTION

The Patton Model 2020RC Interface Converter Rack Card lets a synchronous RS-232 device communicate bi-directionally with a synchronous V.35 device. Operating full or half duplex, the Model 2020RC is protocol independent and supports data rates to 384 kbps.

An internal DCE/DTE strap allows the user to configure the Model 2020RC as "DCE to DTE" or "DTE to DCE". In most cases, this eliminates the need for special crossover cables. The Model 2020RC uses Patton's mid-plane architecture and is equipped with dual UD-26 connectors on the rear interface card (adapter cables are available from Patton Electronics).

The Model 2020RC is designed to mount in Patton's 2U high 19" rack chassis and 2/4/8 slot Cluster Boxes. Available power supplies include 120/230V AC and 48/24/12V DC. The Model 2020RC is made in the USA.

## 3.0 CONFIGURATION

This section describes the location and orientation of the Model 2020RC's configuration straps, and details all possible settings. This section also identifies factory default configuration settings.

### 3.1 FRONT CARD CONFIGURATION

The Model 2020RC installs between DTE devices such as terminals and host computers, and DCE devices such as modems, multiplexers and CSU/DSUs. Most often the DTE device will be RS-232, and the DCE device will be V.35. Therefore, **the default DCE/DTE setting for the Model 2020RC is RS-232 DCE to V.35 DTE**, based on how the Model 2020RC "sees" its *own* orientation. For example, if the Model 2020RC sees its own RS-232 port as DCE, it will want to plug into an RS-232 DTE device such as a terminal.

The DCE/DTE strap is located near the rear of the Model 2020RC front card's PC board (see Figure 1, below). The arrows on the strap, and on the PC board itself, indicate the configuration of the Model 2020RC. For example, if the "DCE" arrows on the strap are pointing toward the front of the card (with the "DTE" arrows pointing toward the rear), then the Model 2020RC is wired so that the RS-232 port is a DCE and the V.35 port is a DTE. You can confirm this by reading the "RS-232" and "V.35" arrows on the PC board.

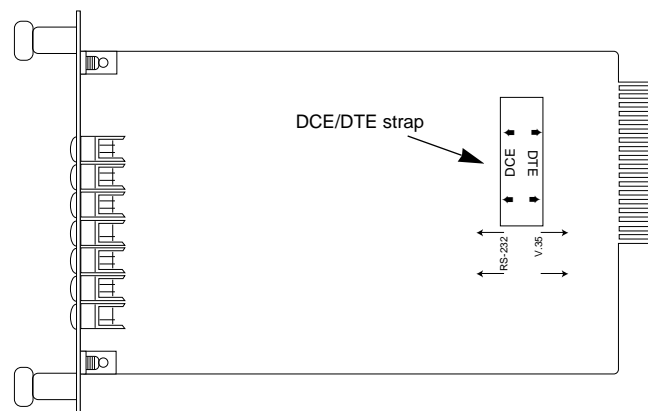

Figure 1. Model 2020RC front card, showing location of the DCE/DTE strap.

To reverse the DCE/DTE orientation of the Model 2020RC, remove the strap and rotate it 180°. Confirm the orientation by checking the arrows on the strap and on the PC board.

**4.0 INSTALLATION**

**3.2 REAR CARD CONFIGURATION**

The rear interface card for the Model 2020RC is equipped with two female UD-26 connectors: one for each port. This card has one configuration jumper (JB4). Figure 2 (below) shows the location of this jumper on the PC board.

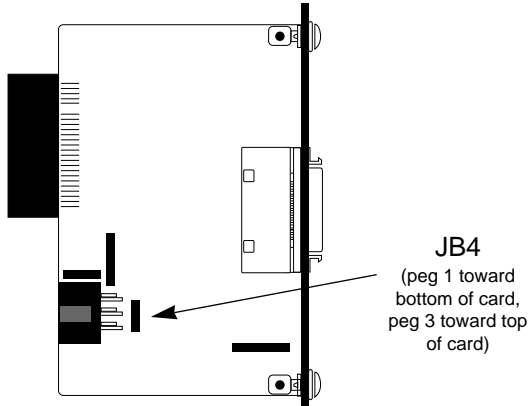

Figure 2. Rear card jumper location

As Figure 3 (below) shows, jumper JB4 has two possible positions: strap covering posts 1 & 2, or strap covering posts 2 & 3. The orientation of the jumper with respect to pin positions is shown in Figure 4 (above).



Figure 3. Possible function card strap positions

**SGND & FRGND (JB4)**

In the connected position, this jumper links UD-26 pin 7 (Signal Ground) and frame ground. In the open position, pin 1 is "lifted" from frame ground.

**JB4**

Position 1&2 = SGND (UD-26 pin 7) and FRGND Connected

Position 2&3 = SGND (UD-26 pin 7) and FRGND Not Connected

This section describes the functions of the Model 1000R16P rack chassis, tells how to install front and rear Model 2020RC cards into the chassis and provides diagrams for wiring up the interface connections correctly.

**4.1 THE MODEL 1000R16P RACK CHASSIS**

The 1000R16P Rack Chassis (shown in Figure 4, below) has sixteen short range modem card slots, plus its own power supply. Measuring only 3.5" high, the 1000R16P is designed to occupy only 2U in a 19" rack. Sturdy front handles allow the 1000R16P to be extracted and transported conveniently.

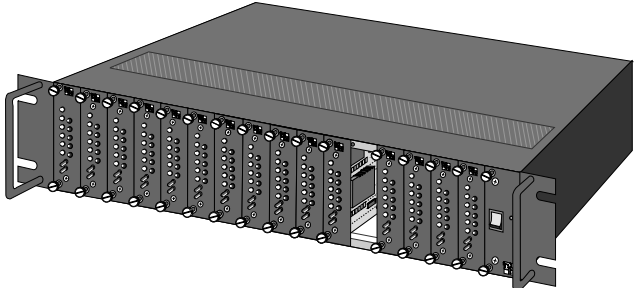

Figure 4. Model 1000R16P Rack Chassis with Power Supply

**4.1.1 THE RACK POWER SUPPLY**

The power supply included in the Model 1000R16P rack uses the same mid-plane architecture as the modem cards. The front card of the power supply slides in from the front, and the rear card slides in from the rear. They plug into one another in the middle of the rack. The front card is then secured by spring loaded thumb screws and the rear card by conventional metal screws.

**WARNING!** There are no user-serviceable parts in the power supply section of the Model 2020RC. Voltage setting changes and fuse replacement should only be performed by qualified service personnel. Contact Patton Electronics Technical support at (301)975-1007 for more information.

(continued)

## Switching the Power Supply On and Off

The power switch is located on the front panel. When plugged in and switched on, a red front panel LED will glow. Since the Model 1000R16P is a "hot swappable" rack, *it is not necessary for any cards to be installed before switching on the power supply*. The power supply may be switched off at any time without harming the installed cards.

**NOTE:** Please refer to the Model 1000RP Series User Manual *AC and DC Rack Mount Power Supplies* for fuse and power card replacement information.

## 4.2 INSTALLING THE MODEL 2020RC INTO THE CHASSIS

The Model 2020RC is comprised of a front Function card and a rear Interface card. The two cards connect in the rack chassis via mating 50 pin card edge connectors. Use the following steps as a guideline for installing each Model 2020RC into the Model 1000R16P rack chassis:

1. Slide the rear Interface card into the back of the chassis along the metal rails.
2. Secure the rear card using the metal screws provided.
3. Slide the Function card into the front of the chassis. It should meet the rear card when it's almost all the way into the chassis.
4. Push the front card *gently* into the card-edge receptacle of the rear card. It should "click" into place.
5. Secure the front card using the spring loaded thumb screws.

**NOTE:** Since the Model 1000R16P chassis allows "hot swapping" of cards, it is not necessary to power down the rack when you install or remove a Model 2020RC.

## 4.3 DCE/DTE CONNECTION

The Model 2020RC rear card has two UD-26 connectors, labeled "A1" and "B1" (see figure 5, below). Port A1 connects to the RS-232 device. Port B1 connects to the V.35 device. As discussed in **Section 3.1**, the ports may be configured as DCE-to-DTE or DTE-to-DCE.

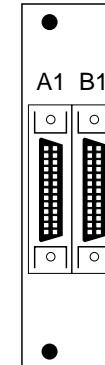

**Figure 5.** Model 2020RC rear interface card, showing connectors

To connect computing devices to ports A1 and B1 on the Model 2020RC, follow these instructions:

1. Configure the Model 2020RC for your specific application according to the instructions in **Section 3.0** of this manual.
2. Connect computing devices to the Model 2020RC using multipair adapter cables (see **Appendix B** for a list of custom adapter cables available from Patton Electronics). Either the RS-232 or the V.35 device may supply the clock. The wiring of your adapter cables should support your system's timing requirements.

**Notice!** Any terminal cable connected to the Model 2020RC must be shielded cable, and the outer shield must be 360 degree bonded—at both ends—to a metal or metalized backshell.

## 5.0 OPERATION

Once you have configured each Model 2020RC and connected the cables, you are ready to operate the units. This section describes the LED status monitors, clocking requirements and the power-up procedure.

### 5.1 LED STATUS MONITORS

The Model 2020RC features thirteen front panel LEDs that indicate the condition of the modem and communication link. Figure 6 (below) shows the positions of the LEDs, and the bullets describe their functions.

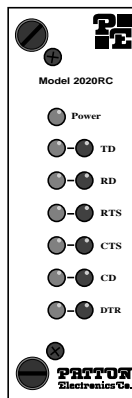

Figure 6. The Model 2020RC front panel, showing LED positions

- **Power** - will glow green when power is applied to the Model 2020RC front card.
- **TD** (Transmit Data) - indicates status of transmit data from the DTE. Red indicates a mark or idle state. Green indicates a space or active state.
- **RD** (Receive Data) - indicates status of receive data from the DCE. Red indicates a mark or idle state. Green indicates a space or active state.
- **RTS** (Request to Send) - indicates status of Request to Send from the DTE. Red indicates a mark or idle state. Green indicates a space or active state.
- **CTS** (Clear to Send) - indicates status of Clear to Send from the DCE. Red indicates a mark or idle state. Green indicates a space or active state.

(continued)

- **CD** (Carrier Detect) - indicates status of Carrier Detect from the DCE. Red indicates a mark or idle state. Green indicates a space or active state.
- **DTR** (Data Terminal Ready) - indicates status of Data Terminal Ready from the DTE. Red indicates a mark or idle state. Green indicates a space or active state.

### 5.2 CLOCKING

The Model 2020RC supports all clocking methods, whether clock is supplied by the DCE or DTE, and whether it is supplied by the V.35 or RS-232 device. No special configuration of the Model 2020RC is required (or possible) with respect to clocking.

### 5.2 POWER-UP

There is no power switch on the Model 2020RC: Power is automatically applied to the 2020RC when its card-edge connector touches the chassis' mid-plane socket, or when the chassis' power is turned on. *Note: The 2020RC is a "hot swappable" card—it will not be damaged by plugging it in or removing it while the rack is powered up.*

**APPENDIX A**

**MODEL 2020RC SPECIFICATIONS**

**Function:** Bidirectional RS-232 to V.35 conversion

**Transmission Format:** Synchronous, transparent to protocol, full or half duplex; passes all appropriate control signals

**External Interface:** Dual UD-26 female high density connectors

**Data Rates:** Up to 384 kbps

**Configuration:** DTE/DCE, strap switchable

**Clocking:** Supplied by the connected devices

**Electrical Interface:** RS-232: RS-232/V.24 compatible; V.35 data and clock receivers: V.35 compliant; V.35 data and clock drivers: 0.55V differential signal; V.35 control signals: RS-232/V.24 compatible

**Indicators:** Bilevel red/green LED indicators for TD, RD, RTS, CTS, CD and DTR; single green LED indicator for Power .

**Power Requirements:** 0.6W @ 10VAC, typical, supplied by rack chassis

**Temperature:** 0-50°C / 32-122°F

**Humidity:** 5 to-95%, noncondensing

**Dimensions:** 0.95"w x 3.1"h x 5.4"l

**Regulatory Approvals:** FCC 15A, UL, CE, EN60950

**APPENDIX B**

**FACTORY REPLACEMENT PARTS**

The Patton Model 2020RC rack system features interchangeable rear half cards, power cords/fuses for international various operating environments and other user-replaceable parts. Model numbers and descriptions for these parts are listed below:

<u>Patton Model #</u>	<u>Description</u>
2065-26M/25F .....	Cable, 6 ft, UD-26M to DB-25F
2065-26M/25M .....	Cable, 6 ft, UD-26M to DB-25M
2065-26M/34F .....	Cable, 6 ft, UD-26M to M/34F
2065-26M/34M .....	Cable, 6 ft, UD-26M to M/34M
1000RPEM .....	120/240V Rear Power Entry Module
1000RPSM-2 .....	120/240V Front Power Supply Module
1000RPEM-DC .....	DC Rear Power Entry Module
1000RPSM-48A .....	48V Front Power Supply Module
1000RPEM-V .....	120/240V CE Compliant Rear Power Entry Module
1000RPSM-V .....	120/240V CE Compliant Front Power Supply Module
0805US .....	American Power Cord
0805EUR .....	European Power Cord CEE 7
0805EURP .....	Europlug Power Cord CEE 7/16
0805UK .....	United Kingdom Power Cord
0805AUS .....	Australia/New Zealand Power Cord
0805DEN .....	Denmark Power Cord
0805FR .....	France/Belgium Power Cord
0805IN .....	India Power Cord
0805IS .....	Israel Power Cord
0805JAP .....	Japan Power Cord
0805SW .....	Switzerland Power Cord
0516FPB1 .....	Single Width Blank Front Panel
0516FPB4 .....	4-Wide Blank Front Panel
0516RPB1 .....	Single Width Blank Rear Panel
0516RPB4 .....	4-Wide Blank Rear Panel
056S1 .....	Set of 16 #4 pan head screws/washers

## APPENDIX C

### PATTON MODEL 2020RC INTERFACE SETTINGS AND ORIENTATION

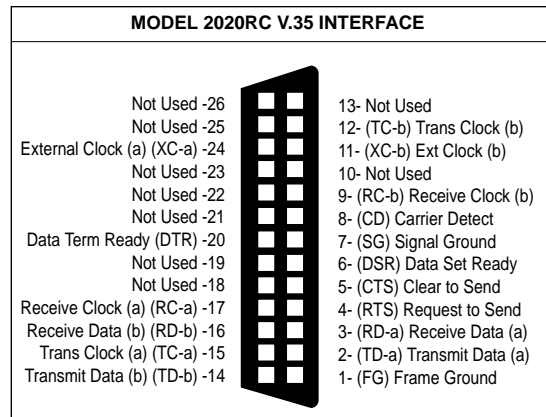
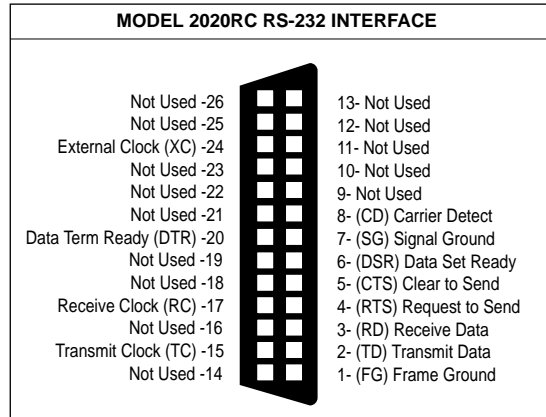

## APPENDIX D

### PATTON MODEL 2020RC BLOCK DIAGRAM

