



HIDEA

Outboard Motor Series

HDF9.9 HDF8 HDF6.8

Owner's Manual

HangZhou Hidea Power Machinery Co. , Ltd.

Nautimarket Srl - ITALY
www.hidea.ws
www.nautimarket.com

Important manual information

To the owner

Thank you for choosing a HIDEA outboard motor. This Owner's Manual contains information needed for proper operation, maintenance and care. A thorough understanding of these simple instructions will help you obtain maximum enjoyment from your HIDEA. If you have any question about the operation or maintenance of your outboard motor, please consult a HIDEA corporation.

In this Owner's Manual particularly important information is distinguished in the following ways.

The Safety Alert Symbol means ATTENTION! BECOME ALERT! YOUR SAFETY IS INVOLVED!

WARNING

Failure to follow WARNING instructions could result in severe injury or death to the machine operator, a bystander, or a person inspection or repairing the outboard motor.

CAUTION

A CAUTION indicates special precautions that must be taken to avoid damage to the outboard motor.

NOTE

A NOTE provides key information to make procedures easier or clearer.

To ensure long product life, HIDEA recommends that you use the product and perform the specified periodic inspections and maintenance by correctly following the instructions in the owner's manual. Note that if you do not follow these instructions, not only may the product break down, but the warranty will also be voided.

NOTE

The F2.5AMH and the standard accessories are used as a base for the explanations and illustrations in this manual. Therefore some items may not apply to every model.

Table of contents

General information	1
Safety information	1
Important labels	3
Warning labels	3
Caution labels	4
Fueling instructions	5
Gasoline	5
Engine oil	5
Propeller selection	6
Basic components	7
Main components	7
Fuel tank cap	8
Air vent screw	8
Gear shift lever	8
Throttle grip	8
Throttle friction adjuster	9
Engine stop lanyard switch	9
Engine stop button	9
Choke knob for pull type	10
Manual starter handle	10
Steering friction adjuster	10
Trim rod	10
Tilt support lever	11
Engine oil warning lamp	11
Operation	13
Installation	13
Mounting the outboard motor	14
Clamping the outboard motor	15
Breaking in engine	15
Procedure for 4-stroke models	15
Pre-operation checks	15
Fuel	15
Controls	15
Engine	15
Checking the engine oil level	15
Filling fuel for built-in tank	16
Operation engine	16
Feeding fuel	16
Starting engine	16
Warming up engine	19
Manual start models	19
Shifting	20
Forward or reverse	20

Table of contents

Stopping engine	20
Procedure	20
Trimming outboard motor	21
Adjusting trim angle	21
Adjusting boat trim	21
Tilting up and down	22
Procedure for tilting up	23
Procedure for tilting down	24
Maintenance	25
Specifications	25
Transporting and storing outboard motor	27
Clamp screw mounting models	27
Storing outboard motor	27
Procedure	28
Lubrication	28
Cleaning the outboard motor	29
Checking painted surface of motor	29
Periodic maintenance	29
Replacement parts	29
Maintenance chart	30
Greasing	31
Cleaning and adjusting spark plug	32
Checking fuel system	32
Inspection idling speed	33
Changing engine oil	34
Checking wiring and connectors	36
Exhaust leakage	36
Water leakage	36
Engine oil leakage	36
Checking propeller	36
Removing the propeller	36
Installing the propeller	37
Changing gear oil	37
Inspecting and replacing anode(s)	38
Coating the boat bottom	38
Trouble Recovery	39
Trouble shooting	39
Temporary action in emergency	42
Impact damage	42
Starter will not operate	43
Emergency Starting Engine	43
Treatment of submerged	45
Procedure	45

General information

Identification numbers record

Outboard motor serial number (SN:)

The outboard motor serial number is stamped on the label attached to the port side of the clamp bracket. Record your outboard motor serial number in the spaces provided to assist you in ordering spare parts from your HIDEA dealer or for reference in case your outboard motor is stolen.

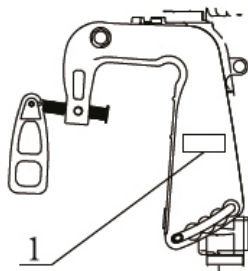

1 Outboard motor serial number location Safety information



- Before mounting or operating the outboard motor, read this entire manual. Read it should give you an understanding of the motor and its operation.
- Before operating the boat, read any owner's or operator's manuals supplied with it and all labels. Be sure you understand each item before operating.
- Do not overpower the boat with this outboard motor. Overpowering the boat could result in loss of control. The rated power of the outboard should be equal to or less than the rated horsepower capacity of the boat. If the rated horsepower capacity of the boat is unknown, consult the dealer or boat manufacturer.
- Do not modify the outboard. Modifications could make the motor unfit or unsafe to use. Incorrect propeller selection and incorrect use may not only cause engine damage, but also adversely affect fuel consumption. Consult your dealer for correct use.
- Never operate after drinking alcohol or taking drugs. About 50% of all boating fatalities involve intoxication.
- Have an approved personal flotation device (PFD) on board for every occupant. It is a good idea to wear a PFD whenever boating. At a minimum, children and non-swimmers should always wear PFDs, and everyone should wear PFDs when there are potentially hazardous boating conditions.
- Gasoline is highly flammable, and its vapors are flammable and explosive. Handle and store gasoline carefully. Make sure there are no gas fumes or leaking fuel before starting the engine.
- This product emits exhaust gases which contain carbon monoxide, a colorless, odorless gas which may cause brain damage or death when inhaled. Symptoms include nausea, dizziness, and drowsiness. Keep cockpit and cabin areas well ventilated. Avoid blocking exhaust outlets.
- Check throttle, shift, and steering for proper operation before starting the engine.
- Attach the engine stop switch lanyard cord to a secure place on your clothing, or your arm or leg while operation. If you accidentally leave the helm, the cord will pull from the switch, stopping the engine.
- Know the marine laws and regulations where you will be boating -----and obey them.
- Stay informed about the weather. Check weather forecasts before boating. Avoid boating in hazardous weather.

General information

- Tell someone where you are going: leave a Float Plan with a responsible person. Be sure to cancel the Float Plan when you return.
- Use common sense and good judgment when boating. Know your abilities, and be sure you understand how your boat handles under the different boating conditions you may encounter. Operate within your limits, and the limits of your boat. Always operate at safe speeds, and keep a careful watch for obstacles and other traffic.
- Always watch carefully for swimmers during the engine operation.
- Stay away from swimming areas.
- When a swimmer is in the water near you shift into neutral and shut off the engine.
- Do not illegally discard empty containers used to replace or replenish oil. For the correct processing of empty containers, consult the dealer where you purchased the oil.
- When replacing oils used to lubricate the product (engine or gear oil), be sure to wipe away any spilt oil. Never pour oil without using a funnel or similar device. If necessary, verify the necessary replacement procedure with the dealer.
- Never illegally discard (dump) the product. Recommends consulting the dealer on discarding the product.

Read manuals and labels

Before operation or working on this motor:

Read this manual.

Read any manuals supplied with the boat.

Read all label on the outboard motor and the boat.

If you need any additional information, contact your HIDEA dealer.

WARNING LABELS

If these labels are damaged or missing, contact your HIDEA dealer for replacements.

HDF15 HDF3.5

General information

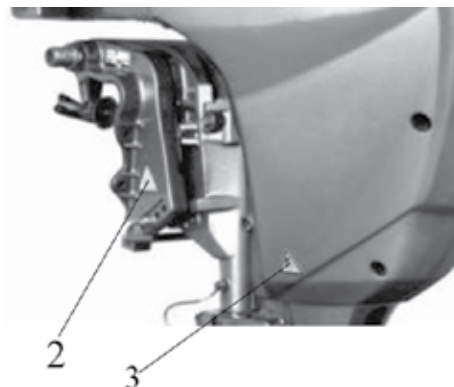

1



Warning

Do not smoke when refuelling or connecting fuel supply, and keep away from sparks, flames, or other sources of ignition.

Warning:

Do not smoke when refueling or connecting fuel supply, and keep away from sparks, flames, or other sources of ignition.

2



Warning

Make sure people are clear of the outboard motor when tilting up and down, also be careful not to pinch any body parts between the drive unit and engine bracket.

Warning

Make sure people are clear of the outboard motor when tilting up and down, also be careful not to pinch any body parts between the drive unit and engine bracket.

3



Warning

Make sure the outboard is out of gear and stop the engine when close to anyone in the water e.g. swimmer, water skier, rescue .

Make sure the outboard is out of gear and stop the engine when close to anyone in the water e.g.

4



Warning of high temperature.

Important labels

Warning labels

General information

WARNING

Be sure shift control is in neutral before starting engine.(except 2.5hp)

Do not touch or remove electrical parts when starting or during operation.

Keep hands, hair, and clothes away from flywheel and other rotating parts while engine is running.

Label

WARNING

This engine is equipped with a neutral starting device.

The engine will not start unless the shift control is in neutral position.

Label

WARNING

LEAKING FUEL COULD CAUSE A FIRE.

Before tilting up the engine or laying it on its side:

- Turn the fuel cock to the “closed” position.
- Tighten the air-vent screw on the fuel tank cap.

Caution labels

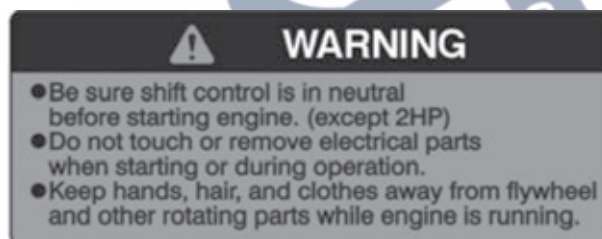

Be sure shift control is in neutral before starting engine.(except 2HP)

Do not touch or remove electrical parts when starting or during operation.

Keep hands,hair,and clothes away from flywheel and other rotating parts while engine is running



This engine is equipped with a neutral starting device.
The engine will not start unless the shift control is in neutral position

General information

Label

CAUTION

Notice

This side up.



Fueling instructions

GASOLINE AND ITS VAPORS ARE HIGHLY FLAMMABLE AND EXPLOSIVE!

- Do not smoke when refueling, and keep away from sparks, flames, or other sources of ignition.
- Stop engine before refueling.
- Refuel in a well-ventilated area. Refuel portable fuel tanks off the boat.
- Take care not to spill gasoline. If gasoline spills, wipe it up immediately with dry rags.
- Do not overfill the fuel tank.
- Tighten the filler cap securely after refueling.
- If you should swallow some gasoline, inhale a lot of gasoline vapor, or get gasoline in your eyes, get immediate medical attention.
- If any gasoline spills onto your skin, immediately wash with soap and water. Change clothing if gasoline spills on it.
- Touch the fuel nozzle to the filler opening or funnel to help prevent electrostatic sparks.

CAUTION

Use only new clean gasoline which has been stored in clean containers and is not contaminated with water or foreign matter.

Recommended gasoline:
Regular unleaded gasoline

Gasoline

If knocking or pinging occurs, use a different brand of gasoline or premium unleaded fuel.

Engine oil

Recommended engine oil:

4-stroke motor oil with a combination of the following SAE and API oil classifications

Engine oil type SAE:

10W-30 or 25W-40

Engine oil grade API:

SE, SF, SG, SH, SJ, SL

Engine oil quantity(excluding oil filter):

0.8L(0.85 US qt) (0.70 Imp.qt)

General information

NOTE

If the recommended engine oil grades are not available, select an alternative from the following chart according to the average temperatures in your area.

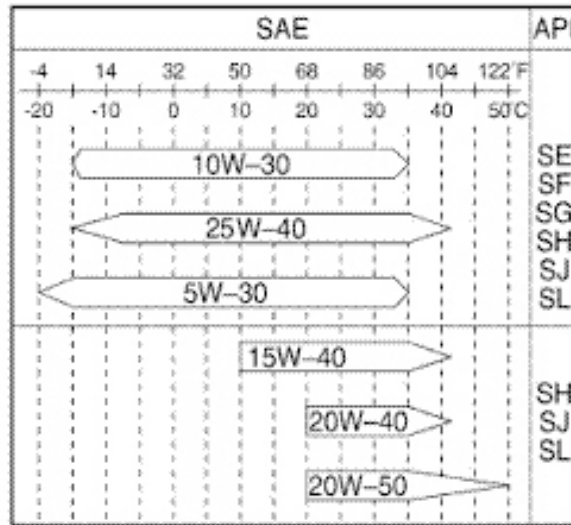

CAUTION

All 4-stroke engines are shipped from the factory without engine oil.

Propeller selection

The performance of your outboard motor will be critically affected by your choice of propeller, as an incorrect choice could adversely affect performance and could also seriously damage the motor. Engine speed depends on the propeller size and boat load. If engine speed is too high or too low for good engine performance, this will have an adverse effect on the engine.

For a greater operating load, a smaller-pitch propeller is more suitable as it enables the correct engine speed to be maintained. Conversely, a larger-pitch propeller is more suitable for a smaller operation load.

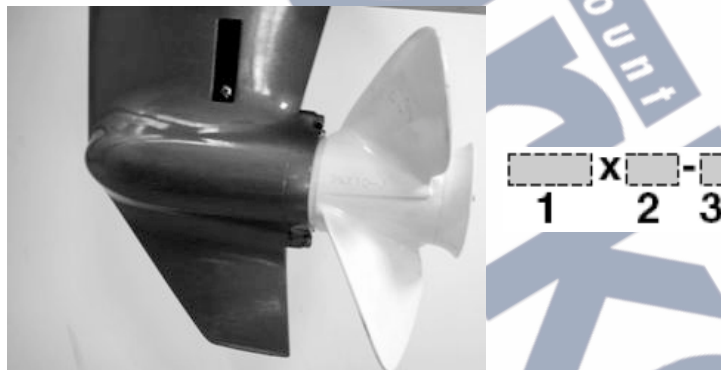

NOTE

If the recommended engine oil grades are not available, select an alternative temperatures in your area.

1. Propeller diameter in inches
2. Propeller pitch in inches
3. Type of propeller (propeller mark)

NOTE

Select a propeller which will allow the engine to reach the middle or upper half of the operation range at full throttle with the maximum boat load. If operation conditions such as light boat loads then allow the engine r/min to rise above the maximum recommended range, reduce the throttle setting to maintain the engine in the proper operation range.

Basic components

Main components

NOTE

- May not be exactly as shown; also may not be included as standard equipment on all models.

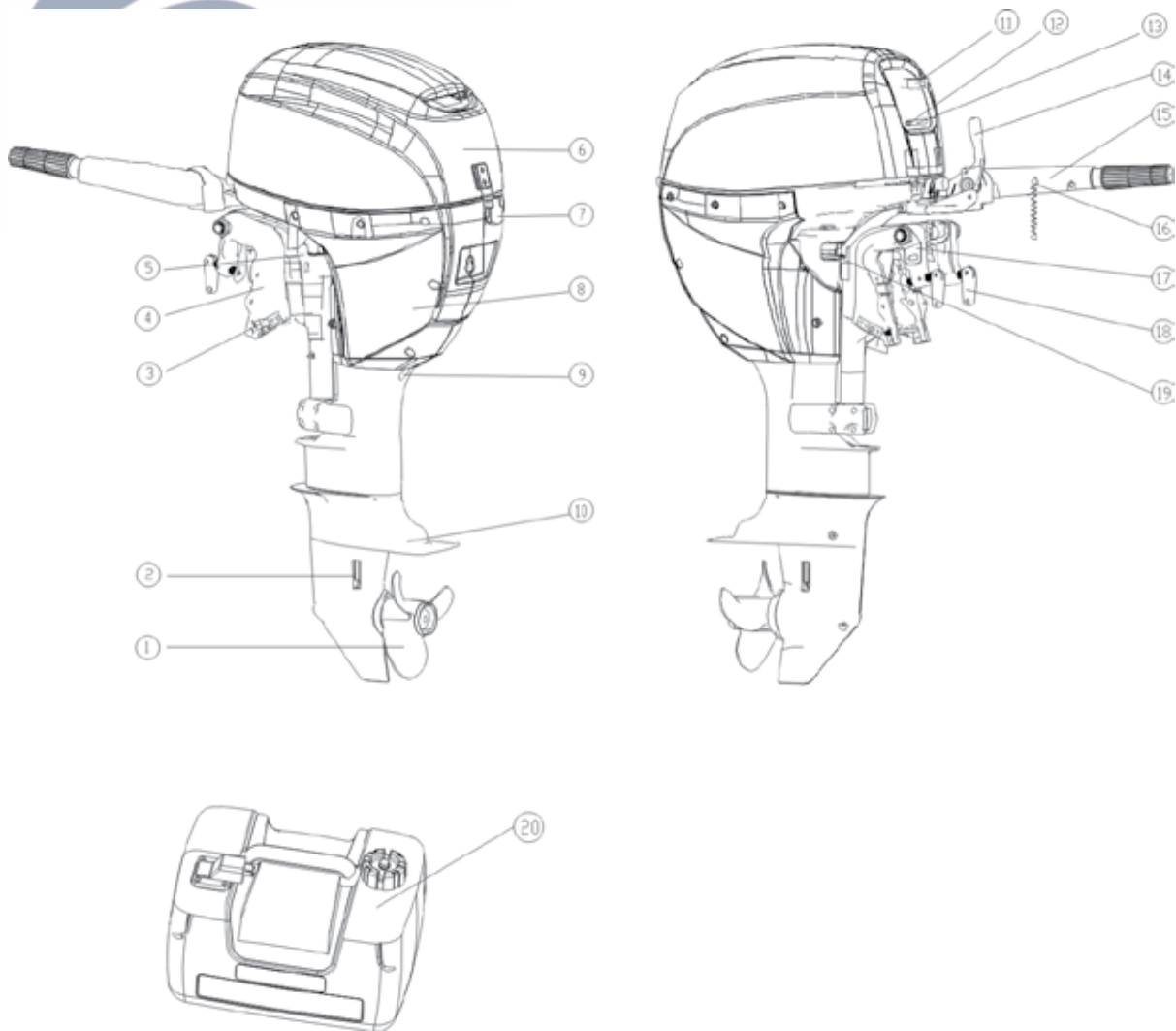

1. Propeller
2. Inlet cover
3. Trim rod
4. Clamp bracket
5. Swivel bracket
6. Top cowling
7. Lock handle
8. Decorate cover
9. Oil outlet
10. Under water device casing
11. Manual starter handle
12. Choke knob
13. Warning indicator
14. Gear shift lever
15. Tiller handle
16. Engine stop button
17. Rope attachment
18. Transom clamp handle
19. Steering rod component
20. Fuel tank

Basic components

Fuel tank cap

This cap seals the fuel tank. When removed, the tank can be filled with fuel. To remove the cap, turn it counterclockwise.



Air vent screw

This screw is on the fuel tank cap. To loosen the screw, turn it counterclockwise.

Tiller handle

To change direction, move the tiller handle to the left or right as necessary.



Throttle grip

The throttle grip is on the tiller handle. Turn the grip counterclockwise to increase speed and clockwise to decrease speed.



Basic components

Throttle friction adjuster

A friction device provides adjustable resistance to movement of the throttle grip or the remote control lever, and can be set according to operator preference.

To increase resistance, turn the adjuster clockwise. To decrease resistance, turn the adjuster counterclockwise.

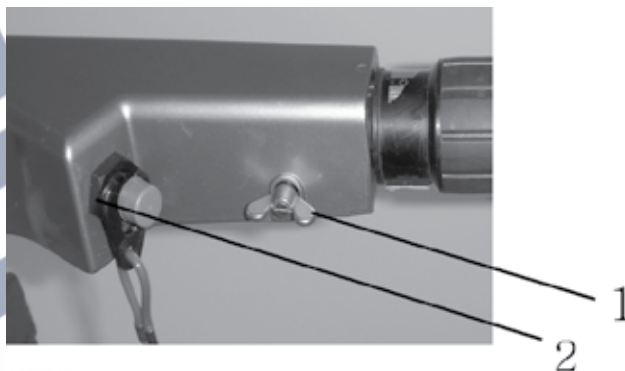

1. Throttle friction adjuster
2. Engine stop lanyard switch

WARNING

Do not over tighten the friction adjuster. If there is too much resistance, it could be difficult to move throttle lever or grip, which could result in an accident.

When constant speed is desired, tighten the adjuster to maintain the desired throttle setting.

Engine stop lanyard switch

The stop switch lock must be attached to the engine stop switch for the engine to run. The hook should be attached to a secure place on the operators clothing, or arm or leg. Should the operator fall overboard or leave the helm, the hook will pull out the stop switch lock, stopping ignition to the engine. This will prevent the boat from running away under power.

WARNING

Attach the engine stop switch lanyard to a secure place on your clothing, or your arm or leg while operating.

Do not attach the lanyard to clothing that could tear loose. Do not route the lanyard where it could become entangled, preventing it from functioning.

Avoid accidentally pulling the lanyard during normal operation. Loss of engine power means the loss of most steering control. Also, without engine power, the boat could slow rapidly. This could cause people and objects in the boat to be thrown forward.

NOTE

The engine cannot be started with the stop switch lock removed.

Engine stop button

To open the ignition circuit and stop the engine, push this button.

Basic components

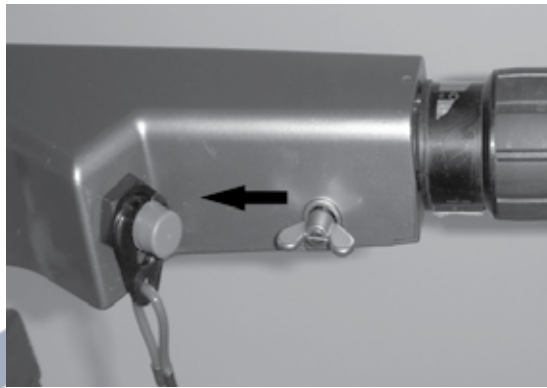

Choke knob for pull type

To supply the engine with the rich fuel mixture required start, pull out this knob.

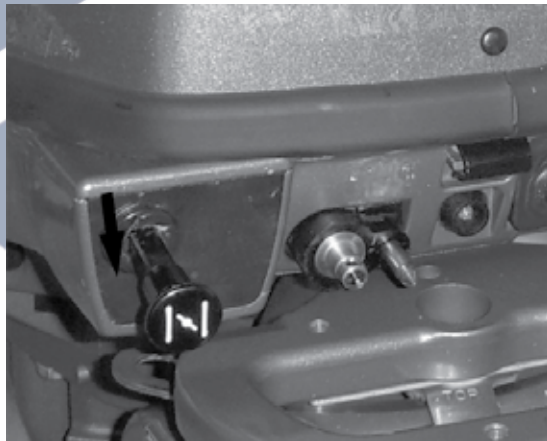

Manual starter handle

To start the engine, first gently pull the handle out until resistance is felt. From that position, then pull the handle straight out quickly to crank the engine.



Steering friction adjuster

A friction device provides adjustable resistance to the steering mechanism, and can be set according to operator preference. An adjusting screw or bolt is located on the swivel bracket.

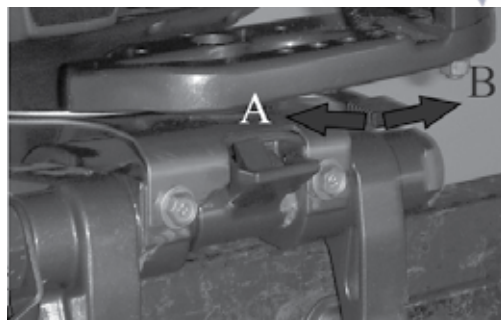

To increase resistance, turn the adjuster clockwise.

To decrease resistance, turn the adjuster counterclockwise

Basic components

WARNING

Do not over tighten the friction adjuster. If there is too much resistance, it could be difficult to steer, which could result in an accident.

Thrust rod

The position of the thrust rod determines the minimum trim angle of the outboard motor in relation to the transom.

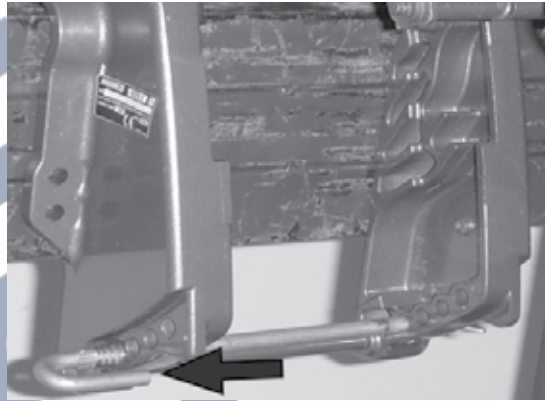

Tilt support lever

To keep the outboard motor in the tilted up position, lock the tilt support lever to the clamp bracket.

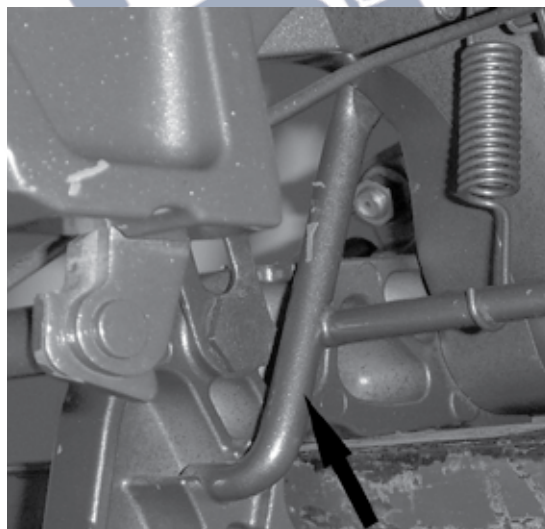

Top cowling lock lever

To remove the engine top cowling, pull up the lock lever and lift off the cowling. When installing the cowling, check to be sure it fits properly in the rubber seal. Then lock the cowling by moving the lever antorse.



Basic components

Engine oil warning lamp

Oil pressure is required to lubricate internal engine parts. When the warning lamp (Red) is off, it indicates that oil pressure is present.



WARNING

Never run the engine if the warning lamp is on or blinking on and off

When the warning lamp is on or blinking on and off, stop the engine immediately and check the engine oil level.

If the oil level is lower than the appropriate level: Replenish engine oil.

If the oil level is within the appropriate level: Consult with your dealer.

Operations

Installation

Incorrect engine height or obstructions to smooth water flow (such as the design or condition of the boat, or accessories such as transom ladders or depth finder transducers) can create airborne water spray while the boat is cruising. Severe engine damage may result if the motor is operated continuously in the presence of airborne water spray.

During water testing check the buoyancy of the boat, at rest, with its maximum load. Check that the static water level on the exhaust housing is low enough to prevent water entry into the powerhead, when water rises due to waves when the outboard is not running

Mounting the outboard motor

- Overpowering a boat could cause severe instability. Do not install an outboard motor with more horsepower than the maximum rating on the capacity plate of the boat. If the boat does not have a capacity plate, consult the boat manufacturer.
- The information presented in this section is intended as reference only. It is not possible to provide complete instructions for every possible boat and motor combination. Proper mounting depends in part on experience and the specific boat and motor combination.

Improper mounting of the outboard motor could result in hazardous conditions such as poor handling, loss of control, or fire hazards. Observe the following:

- For permanently mounted models, your dealer or other person experienced in proper rigging should mount the motor. If you are mounting the motor yourself, you should be trained by an experienced person.
- For portable models, your dealer or other person experienced in proper outboard motor mounting should show you how to mount your motor.

Mount the outboard motor on the center line(keel line) of the boat, and ensure that the boat itself is well balanced. Otherwise the boat will be hard to steer. For boats without a keel or which are asymmetrical, consult your dealer.

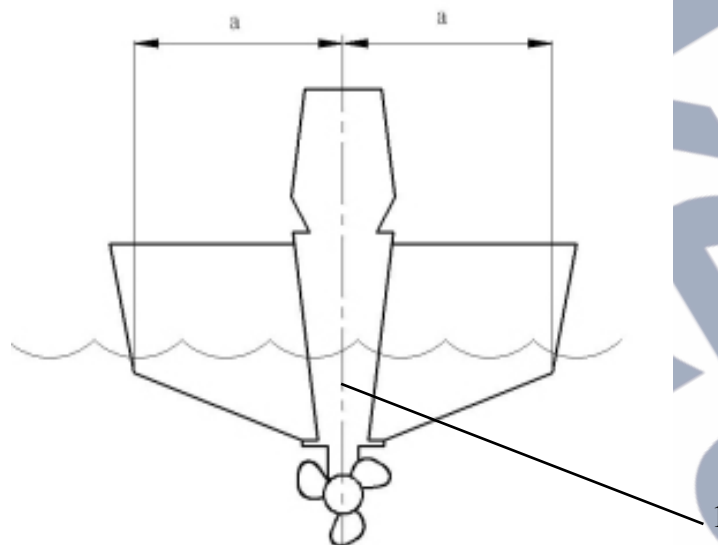

1.Center line(keel line)

Operations

Mounting height

To run your boat at optimum efficiency, the water resistance (drag) of the boat and outboard motor must be made as little as possible. The mounting height of the outboard motor greatly affects the water resistance. If the mounting height is too high, cavitation tends to occur, thus reducing the propulsion; and if the propeller tips cut the air, the engine speed will rise abnormally and cause the engine to overheat. If the mounting height is too low, the water resistance will increase and thereby reduce engine efficiency. Mount the outboard motor so that the anticavitation plate is between the bottom of the boat and a level 30-50mm (1.2-2 in.) below it.

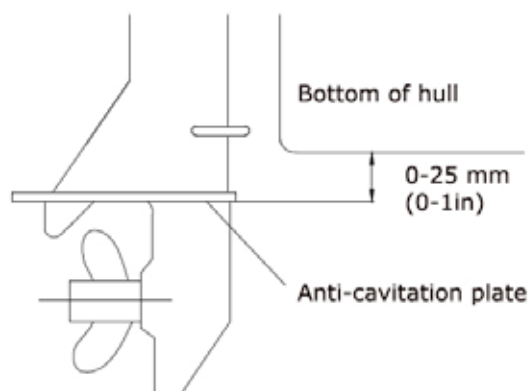

NOTE:

- The optimum mounting height of the outboard motor is affected by the boat and motor combination and the desired use. Test runs at different heights can help determine the optimum mounting height. Consult your boat manufacturer for further information on determining the proper mounting height.

Clamping the outboard motor

1. Place the outboard motor on the transom so that it is positioned as close to the center as possible. Tighten the transom clamp screws evenly and securely. Occasionally check the clamp screws for tightness during operation of the outboard motor because they could become loose due to engine vibration.

WARNING

Loose clamp screws could allow the outboard motor to fall off or move on the transom. This could cause loss of control and serious injury. Make sure the transom screws are tightened securely. Occasionally check the screws for tightness during operation.

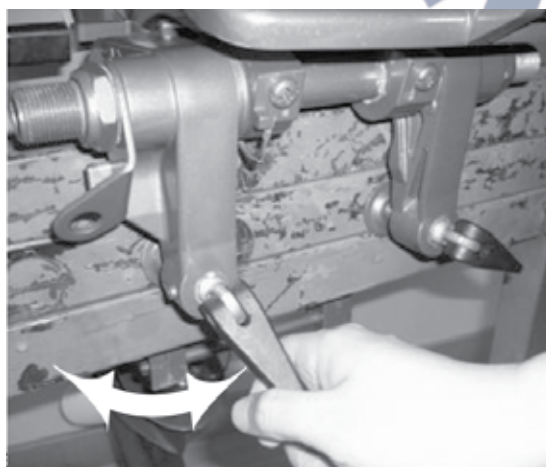

Operations

2. If the engine restraint cable attachment is equipped on your engine, an engine restraint cable or chain should be used. Attach one end to the engine restraint cable attachment and the other to a secure mounting point on the boat. Otherwise the engine could be completely lost if it accidentally falls off the transom.



Breaking in engine

Your new engine requires a period of break-in to allow mating surfaces of moving parts to wear in evenly. Correct break-in will help ensure proper performance and longer engine life.

CAUTION

Failure to follow the break-in procedure could result in reduced engine life or even severe engine damage.

Procedure for 4-stroke models

Run the engine under load (in gear with a propeller installed) as follows.

1. For the first hour of operation:
Run the engine at 3000 r/min or at approximately half throttle.
2. For the second hour of operation:
Run the engine at 4000 r/min or at approximately three-quarter throttle.
3. For the next eight hours of operation:
Avoid continuous operation at full throttle for more than five minutes at a time.
4. After the first 10 hours:
Operate the engine normally.

Pre-operation checks

WARNING

If any item in the preoperation check is not working properly, have it inspected and repaired before operating the outboard motor. Otherwise an accident could occur.

CAUTION

Do not start the engine out of water. Overheating and serious engine damage can occur.

Fuel

- Check to be sure you have plenty of fuel for your trip.
- Make sure there are no fuel leaks or gasoline fumes.

Operations

Controls

- Check throttle, shift, and steering for proper operation before starting the engine.
- The controls should work smoothly, without binding or unusual free play.
- Look for loose or damaged connections.
- Check operation of the starter and stop switches when the outboard motor is in the water.

Engine

- Check the engine and engine mounting.
- Look for loose or damaged fasteners.
- Check the propeller for damage.

Checking the engine oil level

1. Put the outboard motor in an upright position (not tilted).
2. Check the oil level using the oil filler cap to be sure the level falls between the upper and lower marks. Fill with oil if it is below the lower mark, or drain to the specified level if it is above the upper mark.

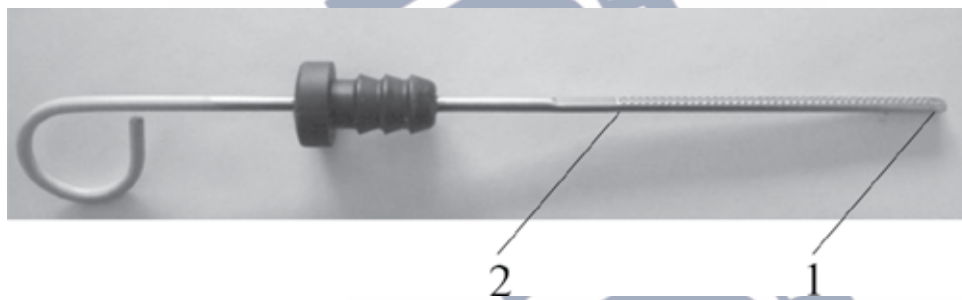

1. Lower level mark
2. Upper level mark

Filling fuel for built-in tank

WARNING

Gasoline and its vapors are highly flammable and explosive. Keep away from sparks, cigarettes, flames, or other sources of ignition.

1. With the outboard motor tilted down (in the vertical running position), remove the fuel tank cap.
2. Use a funnel if the nozzle on the fuel can or pump is not small enough or long enough to fit into the mouth of the fuel tank.
3. Fill the fuel tank carefully.
4. Securely close the cap after refueling. Wipe up any spilled fuel.

Fuel tank capacity:
12.0L (3.17 US gal)(2.64 Imp.gal)

Operations

Operation engine

WARNING

- Before starting the engine, make sure that the boat is tightly moored and that you can steer clear of any obstructions. Be sure there are no swimmers in the water near you.
 - When the air vent screw is loosened, gasoline vapor will be released. Gasoline is highly flammable, and its vapors are flammable and explosive. Refrain from smoking, and keep away from open flames and sparks while loosening the air vent screw.
 - This product emits exhaust gases which contain carbon monoxide, a colorless, odorless gas which could cause brain damage or death when inhaled. Symptoms include nausea, dizziness, and drowsiness. Keep cockpit and cabin areas well ventilated. Avoid blocking exhaust outlets.
-

1. For the built-in tank, loosen the air vent screw on the fuel tank cap by one turn. For the external fuel tank, loosen it on the fuel tank cap by 2 or 3 turns.



2. • Attach the fuel connector to the engine connector. The arrow mark on the primer bulb should be facing the engine. (Separate fuel tank)
- Open the fuel cock. (Integral fuel tank)

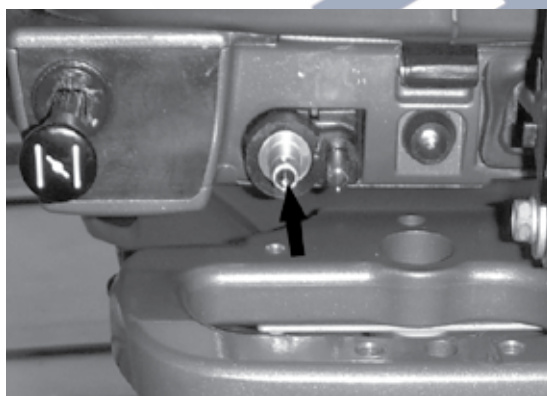

3. Feed fuel to the carburetor by squeezing the primer bulb till it is firm. (Separate fuel tank)

Operations



Starting engine

Manual start models

1. Place the gear shift lever in neutral.

WARNING

Always start the engine in neutral to avoid accidentally moving the boat.



2. If the engine stop switch lanyard is equipped, attach it to a secure place on your clothing, or your arm or leg. Then install the lock plate on the other end of the lanyard into the engine stop switch.

WARNING

- Attach the engine stop switch lanyard to a secure place on your clothing, or your arm or leg while operating.
 - Do not attach the lanyard to clothing that could tear loose. Do not route the lanyard where it could become entangled, preventing it from functioning.
 - Avoid accidentally pulling the lanyard during normal operation. Loss of engine power means the loss of most steering control. Also, without engine power, the boat could slow rapidly. This could cause people and objects in the boat to be thrown forward.
-



Operations

3. Place the throttle grip in the “START” (start) position

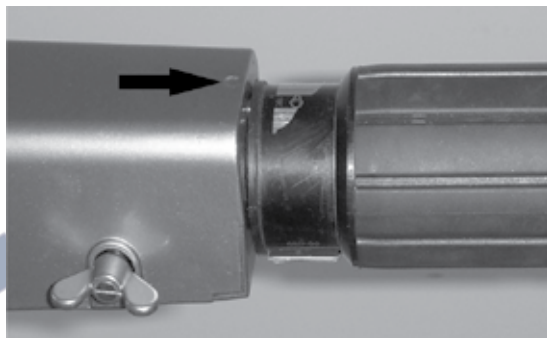

4. Place the choke knob in the “START” (start) position. After the engine starts, return the knob to the “RUN” (run) position.



NOTE:

- When restarting a warm engine, place the choke knob in the ‘RUN’ (run) position.
- If the choke knob is left in the “START” (start) position while the engine is running, the engine will run poorly or stall.

5. Pull the manual starter handle slowly until you feel resistance. Then give a strong pull straight out to start the engine. Repeat if necessary.



6. After the engine starts, slowly return the manual starter handle to the original position before releasing it.

7. Slowly return the throttle grip to the fully closed position.

NOTE:

- When the engine is cold, it needs to be warmed up. For further information, see page 16.
 - If the engine does not start on the first try, repeat the procedure. If the engine fails to start after 4 or 5 tries, open the throttle a small amount (between 1/8 and 1/4) and try again. Also if the engine is warm and fails to start, open the throttle a same amount and try to start the engine again.
-

Warming up engine

Manual start models

1. After starting the engine, return the choke knob to the halfway position. For approximately the first 5 minutes after starting, warm up the engine by operating at one fifth throttle or less. After the engine has warmed up, push the choke knob in fully. Failure to do so will shorten engine life.

NOTE

- If the choke knob is left pulled out after the engine starts, the engine will stall.
 - In temperatures of -5°C or less, leave the choke knob pulled out fully for approximately 30 seconds after starting.
-

2. Check for a steady flow of water from the cooling water pilot hole.

CAUTION

A continuous flow of water from the cooling water pilot hole shows that the water pump is pumping water through the cooling passages. If water is not flowing out of the hole at all times while the engine is running, overheating and serious damage could occur. Stop the engine and check whether the cooling water inlet on the lower case or the cooling water pilot hole is blocked. Consult your dealer if the problem cannot be located and corrected.



Shifting

WARNING

Before shifting, make sure there are no swimmers or obstacles in the water near you.

NOTE:

To change the boat direction or shifting position from forward to reverse or viceversa, first close the throttle so that the engine idles (or runs at low speeds).

Operations

Forward or reverse

1. Place the throttle grip in the fully closed position.

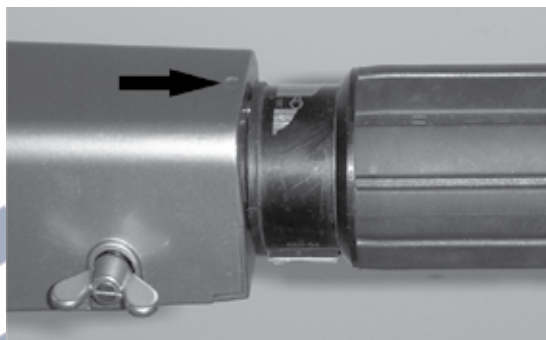

2. Move the gear shift lever quickly and firmly from neutral to forward or reverse.



WARNING

When operating in reverse, go slowly. Do not open the throttle more than half. Otherwise the boat could become unstable, which could result in loss of control and an accident.

Stopping engine

Before stopping the engine, first let it cool off for a few minutes at idle or low speed. Stopping the engine immediately after operating at high speed is not recommended.

Procedure

1. Push and hold the engine stop button until the engine comes to a complete stop.
2. After stopping the engine, tighten the air vent screw on the fuel tank cap and set the fuel cock lever or knob to the closed position, if equipped.
3. Disconnect the fuel line if you are using an external fuel tank.

NOTE

If the outboard motor is equipped with an engine stop switch lanyard, the engine can also be stopped by pulling the lanyard and removing the lock plate from the engine stop switch.

Operations

Trimming outboard motor

The trim angle of the outboard motor helps determine the position of the bow of the boat in the water. Correct trim angle will help improve performance and fuel economy while reducing strain on the engine. Correct trim angle depends upon the combination of boat, engine, and propeller. Correct trim is also affected by variables such as the load in the boat, sea conditions, and running speed.

WARNING

Excessive trim for the operating conditions (either trim up or trim down) can cause boat instability and can make steering the boat more difficult. This increases the possibility of an accident. If the boat begins to feel unstable or is hard to steer, slow down and/or readjust the trim angle.

Adjusting trim angle

There are 4 or 5 holes provided in the clamp bracket to adjust the outboard motor trim angle.

1. Stop the engine.
2. Remove the trim rod from the clamp bracket while slightly tilting the outboard motor up.

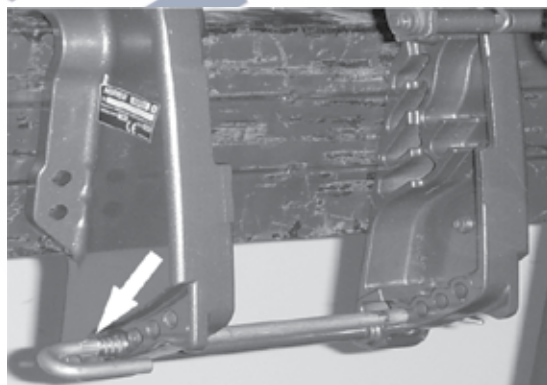

3. Reposition the rod in the desired hole.

To raise the bow (“trim-out”), move the rod away from the transom.

To lower the bow (“trim-in’), move the rod toward the transom.

Make test runs with the trim set to different angles to find the position that works best for your boat and operating conditions.

WARNING

Stop the engine before adjusting the trim angle.

Use care to avoid being pinched when removing or installing the rod.

Use caution when trying a trim position for the first time. Increase speed gradually and watch for any signs of instability or control problems. Improper trim angle can cause loss of control.

The outboard motor trim angle can be changed approximately 4 degrees by shifting the trim rod one hole.

Adjusting boat trim

When the boat is on plane, a bow-up attitude results in less drag, greater stability and efficiency.

This is generally when the keel line of the boat is up about 3 to 5 degrees. With the bow up, the boat may have a greater tendency to steer to one side or the other. Compensate for this as you

steer. The trim tab can also be adjusted to help offset this effect. When the bow of the boat is down, it is easier to accelerate from a standing start onto plane.

Operations

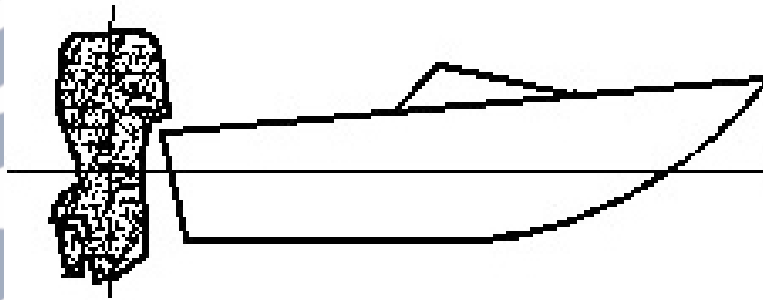

Bow Up

Too much trim-out puts the bow of the boat too high in the water. Performance and economy are decreased because the hull of the boat is pushing the water and there is more air drag. Excessive trim-out can also cause the propeller to ventilate, which reduces performance further, and the boat may “porpoise” (hop in the water), which could throw the operator and passengers overboard.

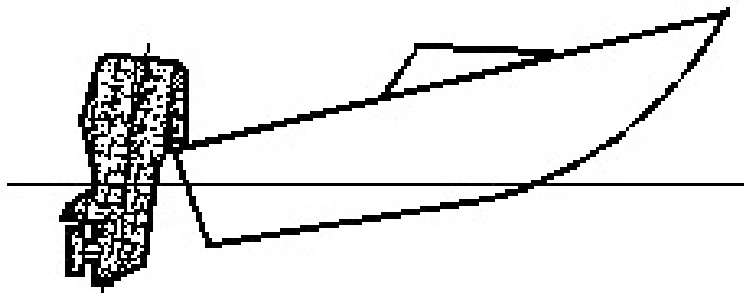

Bow Down

Too much trim-in causes the boat to “plow” through the water, decreasing fuel economy and making it hard to increase speed. Operating with excessive trim-in at higher speeds also makes the boat unstable. Resistance at the bow is greatly increased, heightening the danger of “bow steering” and making operation difficult and dangerous.

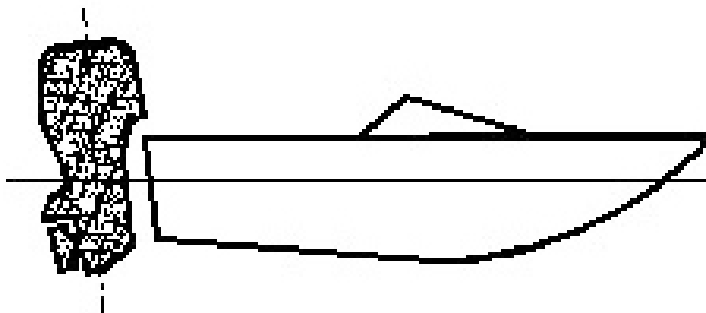

Operations

NOTE:

Depending on the type of boat, the outboard motor trim angle may have little effect on the trim of the boat when operating.

Tilting up and down

If the engine will be stopped for some time or if the boat is moored in shallows, the outboard motor should be tilted up to protect the propeller and casing from damage by collision with obstructions, and also to reduce salt corrosion.

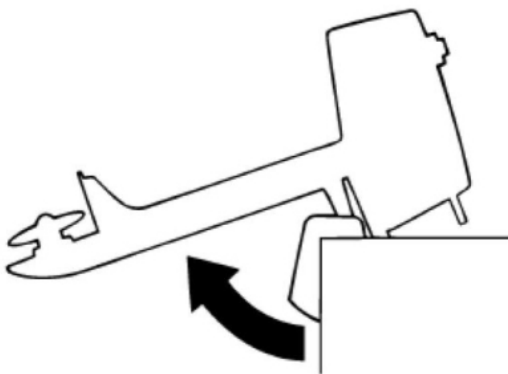

WARNING

Be sure all people are clear of the outboard motor when tilting up and down, also be careful not to pinch any body parts between the drive unit and engine bracket.

WARNING

Leaking fuel is a fire hazard. Tighten the air vent screw and place the fuel cock in the closed position if the outboard motor will be tilted for more than a few minutes. Otherwise fuel may leak.

CAUTION

- Before tilting the outboard motor, follow the procedure under “Stopping engine” in this chapter. Never tilt the outboard motor while the engine is running. Severe damage from overheating can result.
- Do not tilt up the engine by pushing the tiller handle because this could break the handle. Keep the power unit higher than the propeller at all times. Otherwise water could run into the cylinder and cause damage.
- The outboard motor cannot be tilted when in reverse.

Procedure for tilting up

1. Place the gear shift lever in neutral and face the outboard motor forward.



Operations

2. Tighten the air vent screw. On models equipped with a fuel joint, disconnect the fuel line from the outboard motor.



3. Take hold of the top cowl grip and raise outboard to the full up position.



4. The spring loaded tilt lock lever will engage automatically and lock the outboard in full up position.

Procedure for tilting down

1. Slightly tilt the outboard motor up.
2. Pull up on the tilt release lever. Gently lower outboard down.



Maintanance

Specifications

Dimension:

Overall length:

869 mm (34.2 in)

Overall width:

372 mm (14.6 in)

Overall height:

1031 mm (40.6 in)

Transom height :

557 mm (21.9 in)

Weight (AL) :

40 Kg (87.7 lb)

Performance:

Full throttle operating range:

F9.9-F8-F6.8 5000 -6000 r/min

Maximum output

F9.9 7.3 kW@6000 r/min (9.9 HP@6000 r/min)

F8 5.9 kW@6000 r/min (8 HP@6000 r/min)

F6.8

Idling speed (in neutral):

900-1000 r/min

Engine Type

4-stroke L

Displacement:

212 cm³ (12.94 cu. in)

Bore × stroke

56.0 × 43.0 mm (2.2 × 1.7 in)

Ignition system

CDI

Spark plug (NGK):

DPR6EA-9

Spark plug gap:

0.8-1.0 mm (0.031-0.039 in)

Exhaust system:

Through hub exhaust

Cooling system:

Water cooling

Starting system:

Manual

Starting carburetion system:

Choke valve

Valve clearance (cold engine) IN:

0.15-0.20 mm (0.0059-0.0079 in)

Vatve clearance (cold engine) EX:

0.20-0.25 mm (0.0079-0.0098 in)

Drive unit:

Gear positions:

Forward-Neutral

Gear ratio:

2.08 (27/13)

Trim and tilt system:

Manual tilt

Maintenance

Fuel and oil:

Recommended fuel:

Regular unleaded gasoline

Integral fuel tank capacity:

1.1 L (0.29 US gal)

Separate fuel tank capacity:

12 L (3.17 US gal)

Recommended engine oil:

4-stroke outboard motor oil

Engine oil grade API:

API SE, SF, SG, SH, SJ, SL

Engine oil type SAE:

SAE10W30 or SAE25W40

Lubrication:

Trochoid pump

Engine oil quantity (excluding oil filter):

0.8L (0.85 US qt) (0.70 Imp. oz.)

Recommended gear oil

Hypoid gear oil SAE#90

Gear oil quantity

250.0 cm³ (8.45 US oz) (8.82 Imp. oz)

Tightening torque for engine:

Spark plug

25.0 Nm (18.4 ft-lb) (2.5 kgf-m)

Propeller nut:

17.0 Nm (12.5 ft-lb) (1.73 kgf-m)

Engine oil drain bolt:

24.0 Nm (17.7 ft-lb) (2.45 kgf-m)

Maintenance

Transporting and storing outboard motor

WARNING

- Leaking fuel is a fire hazard. When transporting and storing the outboard motor, close the air vent screw and fuel cock to prevent fuel from leaking.
- USE CARE when transporting fuel tank, whether in a boat or car.
- DO NOT fill fuel container to maximum capacity. Gasoline will expand considerably as it warms up and can build up pressure in the fuel container. This can cause fuel leakage and a potential fire hazard.

WARNING

Never get under the lower unit while it is tilted, even if a motor support bar is used. Severe injury could occur if the outboard motor accidentally falls.

CAUTION

Do not use the tilt support lever when trailering the boat. The outboard motor could shake loose from the tilt support and fall. If the motor cannot be trailered in the normal running position, use an additional support device to secure it in the tilt position.

The outboard motor should be trailered and stored in the normal running position. If there is insufficient road clearance in this position, then trailer the outboard motor in the tilt position using a motor support device such as a transom saver bar.

Clamp screw mounting models

When transporting or storing the outboard motor while removed from a boat, keep the outboard motor in the attitude shown.

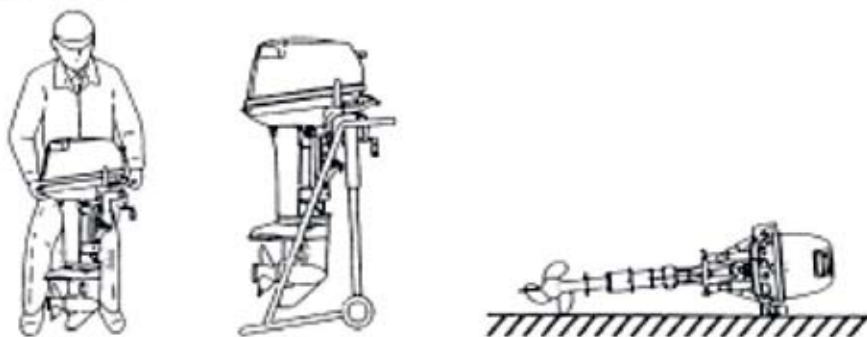

NOTE:

Place a towel or something similar under the outboard motor to protect it from damage.

Storing outboard motor

When storing your outboard motor for prolonged periods of time (2 months or longer), several important procedures must be performed to prevent excessive damage.

CAUTION

- To prevent problems which can be caused by oil entering the cylinder from the sump, keep the outboard motor in the attitude shown when transporting and storing it. If storing or transporting the outboard motor on its side (not upright), put it on a cushion after draining the engine oil.
- Do not place the outboard motor on its side before the cooling water has drained from it completely, otherwise water may enter the cylinder through the exhaust port and cause engine trouble.
- Store the outboard motor in a dry, well-ventilated place, not in direct sunlight.

Maintenance

Procedure

Flushing in a test tank

CAUTION

Do not run the engine without supplying it with cooling water. Either the engine water pump will be damaged or the engine will be damaged from overheating. Before starting the engine, be sure to supply water to the cooling water passages.

1. Wash the outboard motor body using fresh water.
2. Place the fuel cock in the closed position. Tighten the air vent screw on the fuel tank cap.
3. Remove the engine top cowling
4. Remove plug and gasket and flushing attachment.
5. Attach a water hose to the flushing attachment. Turn on the water gently and flush the cooling system for 3 or 5 minutes

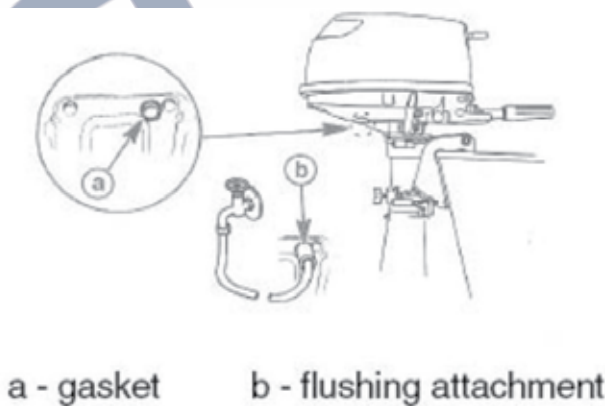

WARNING

- Do not touch or remove electrical parts when starting or during operation.
 - Keep hands, hair, and clothes away from the flywheel and other rotating parts while the engine is running.
-

6. Just prior to turning off the engine, quickly spray “Fogging Oil” into each carburetor. When properly done, the engine will smoke excessively and almost stall.
7. If “Fogging Oil” is not available, run the engine at a fast idle until the fuel system empties and the engine stops.
8. Remove the flushing attachment and reinstall plug and gasket.

NOTE

Cooling system flushing is essential to prevent the cooling system from dogging up with salt, sand, or dirt. In addition, fogging of the engine is mandatory to prevent excessive engine damage due to rust. Perform the flushing and fogging at the same time.

Maintenance

9. Remove the gasoline from the integral fuel tank.
10. If “Fogging Oil” is not available, remove the spark plug. Pour a teaspoonful of clean engine oil into the cylinder. Crank several times manually. Replace the spark plug.
11. Install the top cowling.
12. Drain the cooling water completely out of the motor. Clean the body thoroughly.

Lubrication

1. Grease the spark plug threads and install the spark plug(s) and torque to proper specification.
2. Change the gear oil. Inspect the oil for the presence of water that indicates a leaky seal.
3. Grease all grease fittings.

Cleaning the outboard motor

After use, wash the exterior of the outboard motor with fresh water. Flush the cooling system with fresh water.

Checking painted surface of motor

Check the motor for scratches, nicks, or flaking paint. Areas with damaged paint are more likely to corrode, if necessary, clean and paint the areas.

Periodic maintenance

WARNING

Be sure to turn off the engine when you perform maintenance unless otherwise specified. If you or the owner is not familiar with machine servicing, this work should be done by your HIDEA dealer or other qualified mechanic.

Replacement parts

If replacement parts are necessary, use only genuine HIDEA parts or parts of the same type and of equivalent strength and materials. Any part of inferior quality may malfunction, and the resulting loss of control could endanger the operator and passengers. HIDEA genuine parts and accessories are available from your HIDEA dealer.

Maintenance

Maintenance chart

Frequency of maintenance operations may be adjusted according to the operating conditions, but the following table gives general guidelines. Refer to the sections in this chapter for explanations of each owner-specific action.

When operating in salt water, turbid or muddy water, the engine should be flushed with clean water after each use.

The “●” symbol indicates the check-ups which you may carry out yourself.

The “○” symbol indicates work to be carded out by your HIDEA dealer.

Item	Actions	Initial		Every	
		10 hours (1 month)	50 hours (3 months)	100 hours (6 months)	200 hours (1 year)
Anodes(s)	Inspection/replacement		●/○	●/○	
Cooling water passages	Cleaning		●	●	
Cowling clamp	Inspection				●
Fuel filter (inside built-in fuel tank)	Inspection/cleaning				○
Fuel system	Inspection	●	●	●	
Fuel tank (built-in tank)	Inspection/cleaning				○
Gear oil	Change	●		●	
Greasing points	Greasing			●	
Idling speed (carbure-for models)	Inspection	●/○		●/○	
Propeller and cotter pin	Inspection/replacement		●	●	
Shift link	Inspection/adjustment				○
Thermostat	Inspection/replacement				○
Throttle link/throttle cable/ throttle pick-up timing	Inspection/adjustment				○
Water pump	Cleaning/adjustment/replacement				○
Engine oil	Inspection/change	●		●	
Spark plug(s)	Cleaning/adjustment/replacement	●			●
Valve clearance (OHV)	Inspection/adjustment	○		○	
Exhaust guide, exhaust manifold	Inspection/replacement				○

Maintenance

Greasing

Water resistant grease

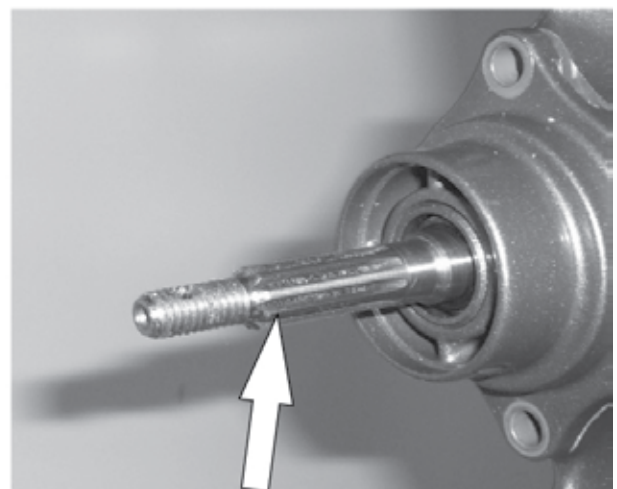
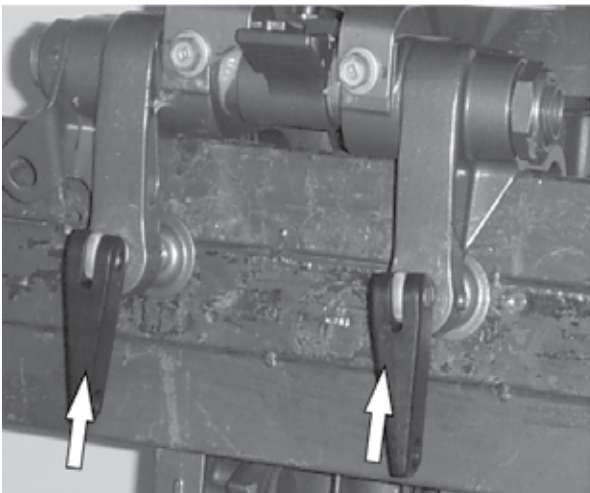
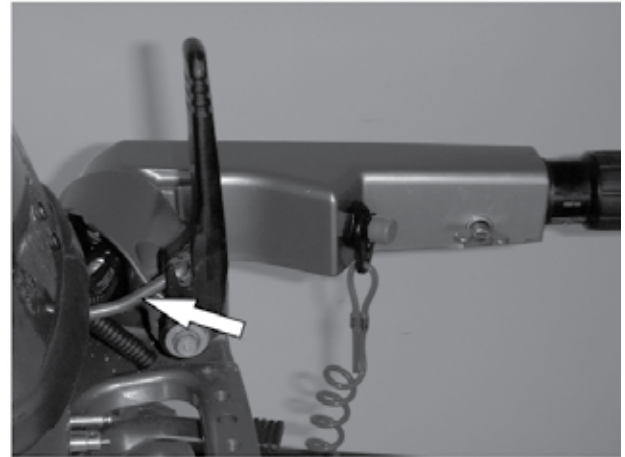
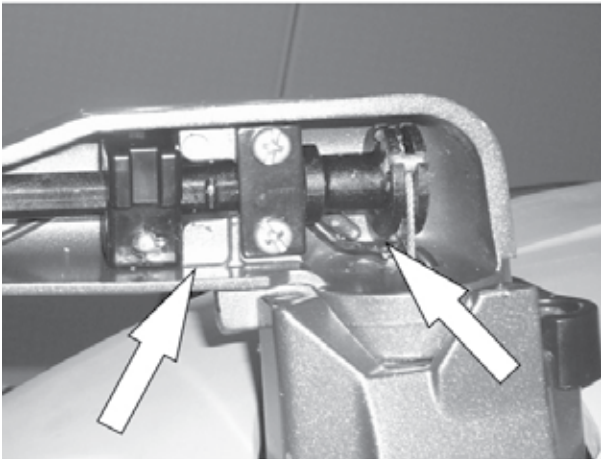
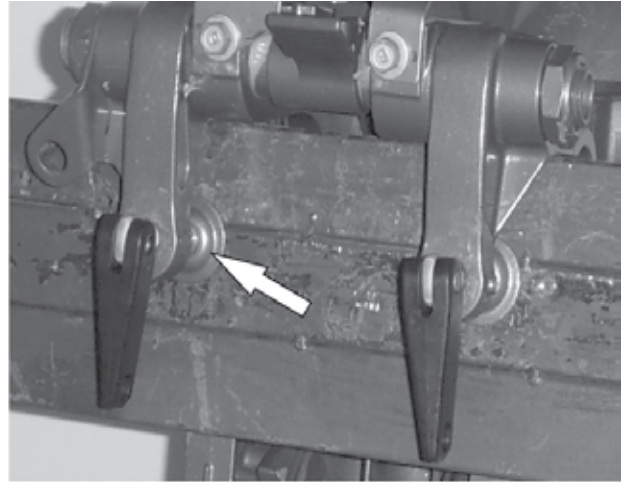
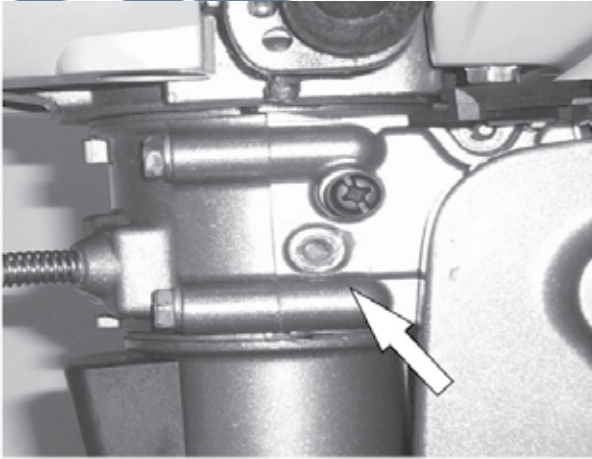

Maintenance

Cleaning and adjusting spark plug

WARNING

When removing or installing a spark plug, be careful not to damage the insulator. A damaged insulator could allow external sparks, which could lead to explosion or fire.

The spark plug is an important engine component and is easy to inspect. The condition of the spark plug can indicate something about the condition of the engine. For example, if the center electrode porcelain is very white, this could indicate an intake air leak or carburetion problem in that cylinder. Do not attempt to diagnose any problems yourself. Instead, take the outboard motor to a HIDEA dealer. You should periodically remove and inspect the spark plug because heat and deposits will cause the spark plug to slowly break down and erode. If electrode erosion becomes excessive, or if carbon and other deposits are excessive, you should replace the spark plug with another of the correct type.

Standard spark plug:
BR6HS-10

Before fitting the spark plug, measure the electrode gap with a wire thickness gauge; adjust the gap to specification if necessary.

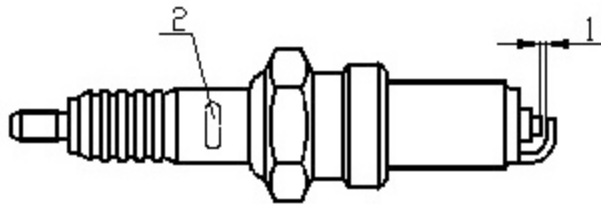

1. Spark plug gap
2. Spark plug I.D. mark (NGK)

Spark plug gap:
0.9-1.0mm (0.035-0.039 in)

When fitting the plug, always clean the gasket surface and use a new gasket. Wipe off any dirt from the threads and screw in the spark plug to the correct torque.

Spark plug torque:
25.0 Nm (18.4ft-lb)(2.55kgf-m)

NOTE

If a torque-wrench is not available when you are fitting a spark plug, a good estimate of the correct torque is 1/4 to 1/2 a turn past fingertight. Have the spark plug adjusted to the correct torque as soon as possible with a torque wrench.

Maintenance

Checking fuel system

WARNING

Gasoline and its vapors are highly flammable and explosive. Keep away from sparks, cigarettes, flames, or other sources of ignition.

WARNING

Leaking fuel can result in fire or explosion.

- Check for fuel leakage regularly.
 - If any fuel leakage is found, the fuel system must be repaired by a qualified mechanic. Improper repairs can make the outboard unsafe to operate.
-

Check the fuel lines for leaks, crack, or malfunction. If a problem is found, your HIDEA dealer or other qualified mechanic should repair it immediately.

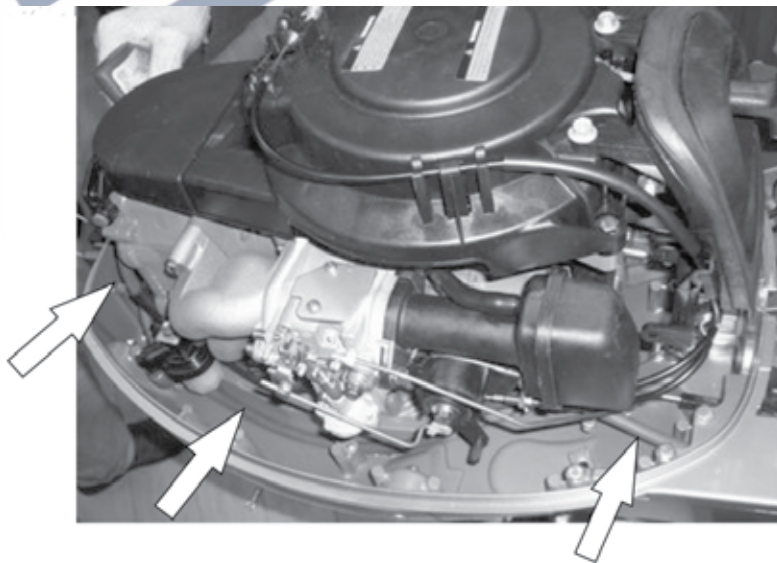

Checkpoints

- Fuel system parts leakage
- Fuel line joint leakage
- Fuel line cracks or other damage
- Fuel connector leakage

Inspecting idling speed

WARNING

Do not touch or remove electrical parts when starting or during operation. Keep hands, hair, and clothes away from the flywheel and other rotating parts while the engine is running.

CAUTION

This procedure must be performed while the outboard motor is in the water. A flushing attachment or test tank can be used.

A diagnostic tachometer should be used for this procedure. Results may vary depending on whether testing is conducted with the flushing attachment, in a test tank, or with the outboard motor in the water.

1. Start the engine and allow it to warm up fully in neutral until it is running smoothly.

Maintenance

NOTE:

Correct idling speed inspection is only possible if the engine is fully warmed up. If not warmed up fully, the idle speed will measure higher than normal. If you have difficulty verifying the idle speed, or the idle speed requires adjustment, consult a HIDEA dealer or other qualified mechanic.

2. Verify whether the idle speed is set to specification. For idle speed specifications, see page 23

Changing engine oil

WARNING

- Avoid draining the engine oil immediately after stopping the engine. The oil is hot and should be handled with care to avoid burns.
- Be sure the outboard motor is securely fastened to the transom or a stable stand.

CAUTION:

- Do not overfill the oil, and be sure the outboard motor is upright (not tilted) when checking and hanging the engine oil.
- If the oil level is above the upper level mark, drain until the level meets the specified capacity. Overfilling the oil could cause leakage or damage.

CAUTION:

Change the engine oil after the first 10 hours of operation, and every 100 hours or at 6-month intervals thereafter. Otherwise the engine will wear quickly.

NOTE:

Change the engine oil when the oil is still warm.

1. Put the outboard motor in an upright position (not tilted).
2. Prepare a suitable container that holds a larger amount than the engine oil capacity. Loosen and remove the drain screw while holding the container under the drain hole. Then remove the oil filler cap. Let the oil drain completely. Wipe up any spilled oil immediately.



Maintenance

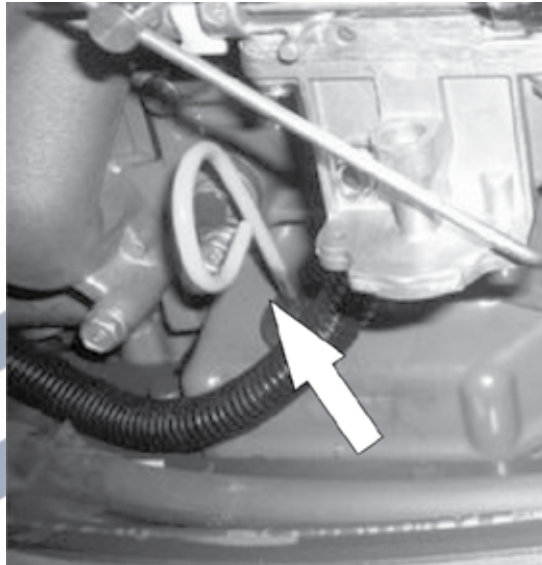

- Put a new gasket on the oil drain screw.
Apply a light coat of oil to the gasket and install the drain screw.

Drain screw tightening torque:
18.0Nm (13.3 ft-lb)(1.84Kgf-m)

NOTE

If a torque wrench is not available when you are installing the drain screw, finger tighten the screw just until the gasket comes into contact with the surface of the drain hole. Then tighten 1/4 to 1/2 turn more. Tighten the drain screw to the correct torque with a torque wrench as soon as possible.

- Add the correct amount of oil through the filler hole. Install the filler cap.

Recommended engine oil:
4-stroke outboard motor oil
Engine oil quantity:
0.8L (0.85US qt)(0.70 1mp.qt)

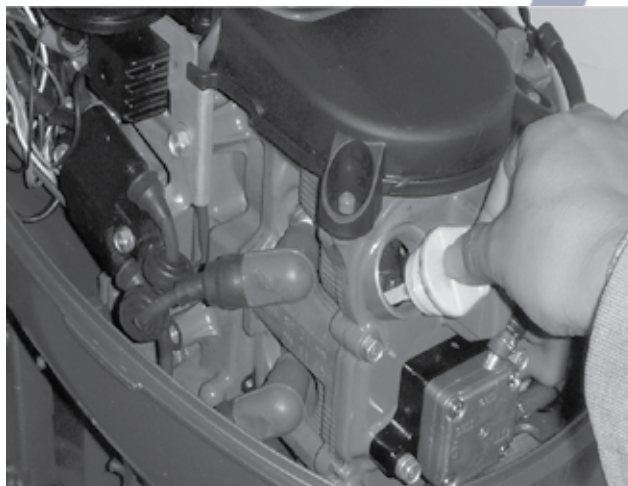

Maintenance

5. Start the engine and watch to make sure the low oil pressure warning indicator turns off. Make sure that there are no oil leaks.

CAUTION

If the low oil pressure warning indicator does not turn off or if there are oil leaks, stop the engine and find the cause. Continued operation with a problem could cause severe engine damage.

6. Turn off the engine and wait 3 minutes. Recheck the oil level using the oil filler cap to be sure the level falls between the upper and lower marks. Fill with oil if it is below the lower mark, or drain to the specified level if it is above the upper mark.

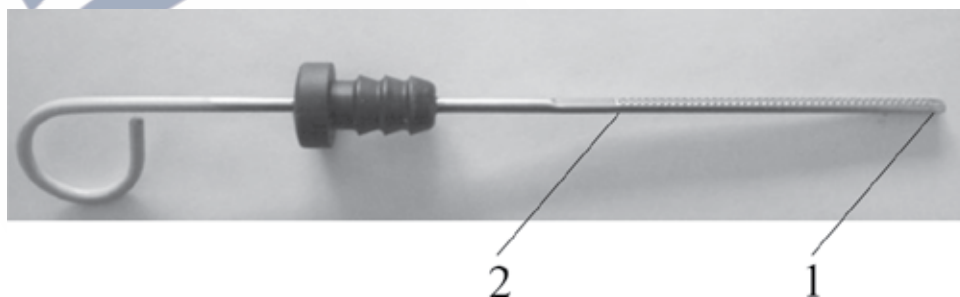

1. Lower level

2. Upper level

7. Dispose of used oil according to local regulations.

NOTE:

- Change the oil more often when operating the engine under adverse conditions such as extended trolling.

Checking wiring and connectors

- Check that each grounding wire is properly secured.
- Check that each connector is engaged secured.

Exhaust leakage

Start the engine and check that no exhaust leaks from the joints between the exhaust cover, cylinder head, and body cylinder.

Water leakage

Start the engine and check that no water leaks from the joints between the exhaust cover, cylinder head, and body cylinder.

Engine oil leakage

Check for oil leaks around the engine.

Checking propeller

WARNING

You could be seriously injured if the engine accidentally starts when you are near the propeller.

- Before inspecting, removing, or installing the propeller, remove the spark plug caps from the spark plugs. Also, place the shift control in neutral, turn the main switch to “OFF” (Off) and remove the key; and remove the lanyard from the engine stop switch.
 - Do not use your hand to hold the propeller when loosening or tightening the propeller nut. Put a wood block between the anti-cavitation plate and the propeller to prevent the propeller from turning.
-

Maintenance

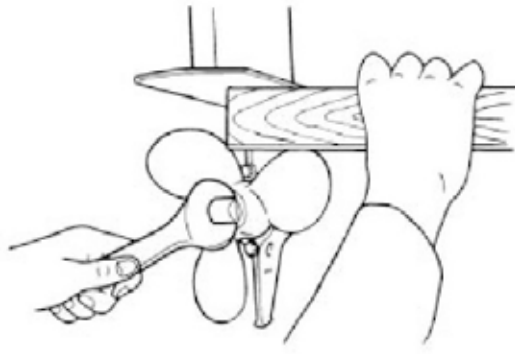

Checkpoints

- Check each of the propeller blades for wear, erosion from cavitation or ventilation, or other damage.
- Check the propeller shaft for damage.
- Check the splines pin for wear or damage.
- Check for fish line tangled around the propeller shaft.
- Check the propeller shaft oil seal for damage.

Removing the propeller

Spline models

1. Straighten the split pin and pull it out using a pair of pliers.
2. Remove the propeller nut and washer.

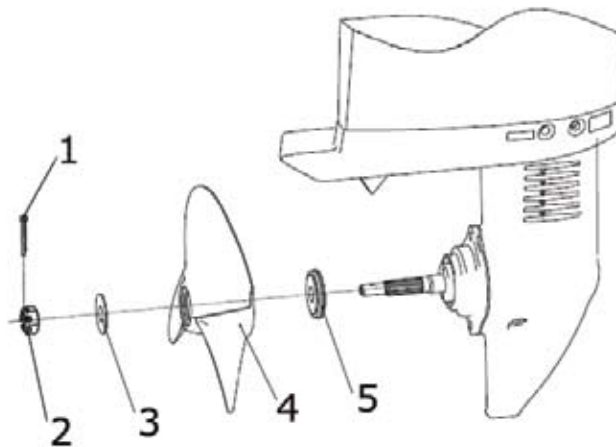

1. Cotter pin
2. Propeller nut
3. Washer
4. Propeller
5. Thrust washer

3. Remove the propeller and thrust holder.

Installing the Propeller

Spline models

CAUTION

- Be sure to install the thrust holder before installing the propeller, otherwise the lower case and propeller boss could be damaged.
- Be sure to use a new cotter pin and bend the ends over securely. Otherwise the propeller could come off during operation and be lost.

Maintenance

1. Apply corrosion resistant grease to the propeller shaft.
2. Install the thrust holder, and propeller on the propeller shaft.
3. Install the washer. Tighten the propeller nut until there is no forward-and-backward movement.
4. Align the propeller nut with the propeller shaft hole. Insert a new cotter pin in the hole and bend the cotter pin ends.



NOTE

If the propeller nut does not align with the propeller shaft hole after tightening it, loosen the nut until it aligns with the hole.

Changing gear oil

WARNING

- Be sure the outboard motor is securely fastened to the transom or a stable stand. You could be severely injured if the outboard motor falls on you.
- Never get under the lower unit while it is tilted, even when the tilt support lever or knob is locked. Severe injury could occur if the outboard motor accidentally falls.

1. Tilt the outboard motor so that the gear oil drain screw is at the lowest point possible.
2. Place a suitable container under the gear case.
3. Remove the gear oil drain screw.

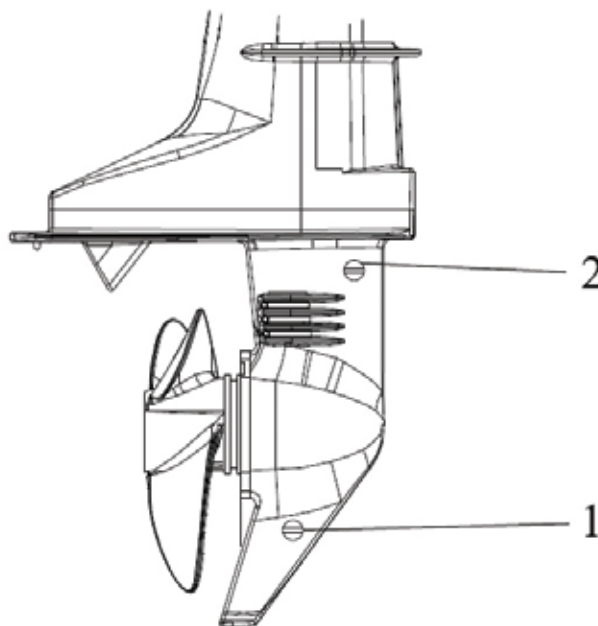

1. Gear oil drain screw
2. Oil level plug

Maintenance

NOTE:

- If a magnetic gear oil drain screw is equipped, remove all metal particles from the screw before installing it.
- Always use new gaskets. Do not reuse the removed gaskets.

4. Remove the oil level plug to allow the oil to drain completely.

CAUTION

Inspect the used oil after it has been drained. If the oil is milky, water is getting into the gear case which can cause gear damage. Consult your dealer for repair of the lower unit seals.

5. With the outboard motor in a vertical position, and using a flexible or pressurized filling device, inject the gear oil into the gear oil drain screw hole.

Recommended gear oil: Hypoid gear oil SAE#90
Gear oil quantity: 195.0 ml (6.6 fl. oz.)

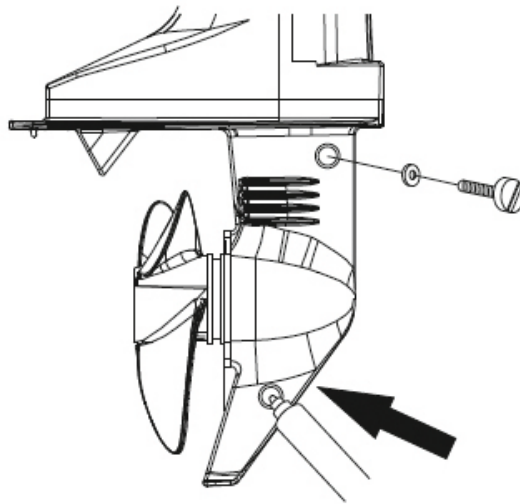

6. When the oil begins to flow out of the oil level plug hole, insert and tighten the oil level plug.
7. Insert and tighten the gear oil drain screw.

Inspecting and replacing anode(s)

HIDEA outboard motors are protected from corrosion by sacrificial anodes. Inspect the external anodes periodically. Remove scales from the surfaces of the anodes.

CAUTION

Do not paint anodes, as this would render them ineffective.

Coating the boat bottom

A clean hull improves boat performance. The boat bottom should be kept as clean of marine growth as possible. If necessary, the boat bottom can be coated with an anti-fouling paint approved for your area to inhibit marine growth.

Do not use anti-fouling paint which includes copper or graphite. These paints can cause more rapid engine corrosion.

Trouble Recovery

Trouble shooting

A problem in the fuel, compression, or ignition systems can cause poor starting, loss of power, or other problems. This section describes basic checks and possible remedies.

Starter will not operate

Q. Are starter components faulty?

A. Have serviced by a yours dealer.

Q. Is shift lever in gear?

A. Shift to neutral.

Engine will not start (starter operates)

Q. Is fuel tank empty?

A. Fill tank with clean, fresh fuel.

Q. Is fuel contaminated or stale?

A. Fill tank with clean, fresh fuel.

Q. Is fuel filter clogged?

A. Clean or replace filter.

Q. Is starting procedure incorrect?

A. See page 21.

Q. Has fuel pump malfunctioned?

A. Have serviced by a HIDEA dealer.

Q. Are spark plug(s) fouled or of incorrect type?

A. Inspect spark plug(s). Clean or replace with recommended type.

Q. Are spark plug cap(s) fitted incorrectly?

A. Check and re-fit cap(s).

Q. Is ignition wiring damaged or poorly connected?

A. Check wires for wear or breaks. Tighten all loose connections. Replace worn or broken wires.

Q. Are ignition parts faulty?

A. Have serviced by a yours dealer.

Q. Is engine stop switch lanyard not attached?

A. Attach lanyard.

Q. Are engine inner parts damaged?

A. Have serviced by a yours dealer.

Engine idles irregularly or stalls

Q. Are spark plug(s) fouled or of incorrect type?

A. Inspect spark plug(s). Clean or replace with recommended type.

Q. Is fuel system obstructed?

A. Check for pinched or kinked fuel line or other obstructions in fuel system.

Trouble Recovery

Q. Is fuel contaminated or stale?

A. Fill tank with clean, fresh fuel.

Q. Is fuel filter clogged?

A. Clean or replace filter.

Q. Have ignition parts failed?

A. Have serviced by a yours dealer.

Q. Has warning system activated?

A. Find and correct cause of warning.

Q. Is spark plug gap incorrect?

A. Inspect and adjust as specified.

Q. Is ignition wiring damaged or poorly connected?

A. Check wires for wear or breaks. Tighten all loose connections. Replace worn or broken wires.

Q. Is specified engine oil not being used?

A. Check and replace oil as specified.

Q. Is thermostat faulty or dogged?

A. Have serviced by a yours dealer.

Q. Are carburetor adjustments incorrect?

A. Have serviced by a yours dealer.

Q. Is fuel pump damaged?

A. Have serviced by a yours dealer.

Q. is air vent screw on fuel tank closed?

A. Open air vent screw.

Q. Is choke knob pulled out?

A. Return to home position.

Q. is motor angle too high?

A. Return to normal operating position.

Q. Is carburetor clogged?

A. Have serviced by a yours dealer.

Q. Is fuel joint connection incorrect?

A. Connect correctly.

Q. is throttle valve adjustment incorrect?

A. Have serviced by a yours dealer.

Q. Is battery cable disconnected?

A. Connect securely.

Trouble Recovery

Indicator lights

Q. Is engine oil level low?.

A. Fill oil tank with specified engine oil.

Q. Is specified engine oil not being used?

A. Check and replace oil with specified type.

Q. Is engine oil contaminated or deteriorated?

A. Replace oil with fresh, specified type.

Q. Is oil filter clogged?

A. Have serviced by a your dealer.

Q. Has oil feed pump malfunctioned?

A. Have serviced by a your dealer.

Engine power loss

Q. Is propeller damaged?

A. Have propeller repaired or replaced.

Q. Is propeller pitch or diameter incorrect?

A. Install correct propeller to operate outboard at its recommended speed (rpm) range.

Q. Is trim angle incorrect?

A. Adjust trim angle to achieve most efficient operation.

Q. Is motor mounted at incorrect height on transom?

A. Have motor adjusted to proper transom height.

Q. Has warning system activated?

A. Find and correct cause of warning.

Q. Is boat bottom fouled with marine growth?

A. Clean boat bottom.

Q. Are spark plug(s) fouled or of incorrect type?

A. Inspect spark plug(s). Clean or replace with recommended type.

Q. Are weeds or other foreign matter tangled on gear housing?

A. Remove foreign matter and clean lower unit.

Q. Is fuel system obstructed?

A. Check for pinched or kinked fuel line or other obstructions in fuel system.

Q. Is fuel filter clogged?

A. Clean or replace filter.

Q. Is fuel contaminated or stale?

A. Fill tank with clean, fresh fuel.

Q. Is spark plug gap incorrect?

A. Inspect and adjust as specified.

Trouble Recovery

Q. Is ignition wiring damaged or poorly connected?

A. Check wires for wear or breaks. Tighten all loose connections. Replace worn or broken wires.

Q. Have electrical parts failed?

A. Have serviced by a yours dealer.

Q. Is specified fuel not being used?

A. Replace fuel with specified type.

Q. Is specified engine oil not being used?

A. Check and replace oil with specified type.

Q. Is thermostat faulty or clogged?

A. Have serviced by a yours dealer.

Q. Is air vent screw closed?

A. Open the air vent screw.

Q. Is fuel pump damaged?

A. Have serviced by a yours dealer.

Q. Is fuel joint connection incorrect?

A. Connect correctly.

Q. Is heat range of spark plug incorrect?

A. Inspect spark plug and replace it with recommended type.

Q. Is engine not responding properly to shift lever position?

A. Have serviced by a yours dealer.

Engine vibrates excessively.

Q. Is propeller damaged?

A. Have propeller repaired or replaced.

Q. Is propeller shaft damaged?

A. Have serviced by a yours dealer.

Q. Are weeds or other foreign matter tangled on propeller?

A. Remove and clean propeller.

Q. Is motor mounting bolt loose?

A. Tighten bolt.

Q. Is steering pivot loose or damaged?

A. Tighten or have serviced by a yours dealer.

Trouble Recovery

Temporary action in emergency

Impact damage

WARNING

The outboard motor can be seriously damaged by a collision while operating or trailering. Damage could make the outboard motor unsafe to operate.

If the outboard motor hits an object in the water, follow the procedure below.



1. Stop the engine immediately.
2. Inspect the control system and all components for damage. Also inspect the boat for damage.
3. Whether damage is found or not, return to the nearest harbor slowly and carefully.
4. Have a HIDEA dealer inspect the outboard motor before operating it again.

Starter will not operate

If the starter mechanism does not operate (the engine cannot be cranked with the starter), the engine can be started with an emergency starter rope.

WARNING

- Use this procedure only in an emergency and only to return to port for repairs.
 - When the emergency starter rope is used to start the engine, the start-in-gear protection device does not operate. Make sure the remote control lever is in neutral. Otherwise the boat could unexpectedly start to move, which could result in an accident.
 - Attach the engine stop switch lanyard to a secure place on your clothing, or your arm or leg while operating.
 - Do not attach the lanyard to clothing that could tear loose. Do not route the cord where it could become entangled, preventing it from functioning.
 - Avoid accidentally pulling the lanyard during normal operation. Loss of engine power means the loss of most steering control. Also, without engine power, the boat could slow rapidly. This could cause people and objects in the boat to be thrown forward.
 - Be sure no one is standing behind you when pulling the starter rope. It could whip behind you and injure someone.
 - An unguarded, rotating flywheel is very dangerous. Keep loose clothing and other objects away when starting the engine. Use the emergency starter rope only as instructed. Do not touch the flywheel or other moving parts when the engine is running. Do not install the starter mechanism or top cowling after the engine is running.
 - Do not touch the ignition coil, spark plug wire, spark plug cap, or other electrical components when starting or operating the motor. You could get an electrical shock.
-

Trouble Recovery

Emergency Starting Engine

1. Remove the top cowling.



2. Shift outboard to neutral position.

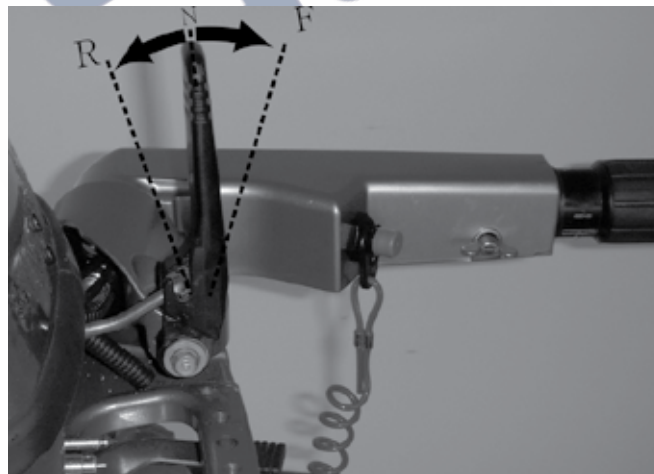

3. Disconnect linkage from rewind starter assembly.

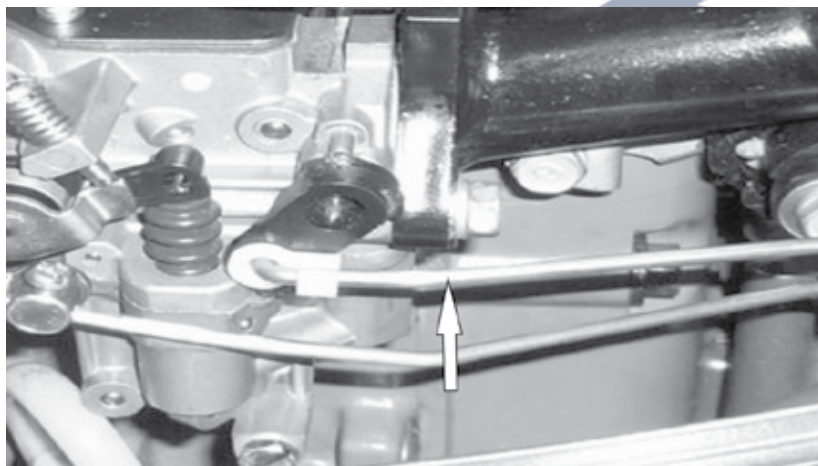

Trouble Recovery

4. Remove three bolts and rewind starter assembly.

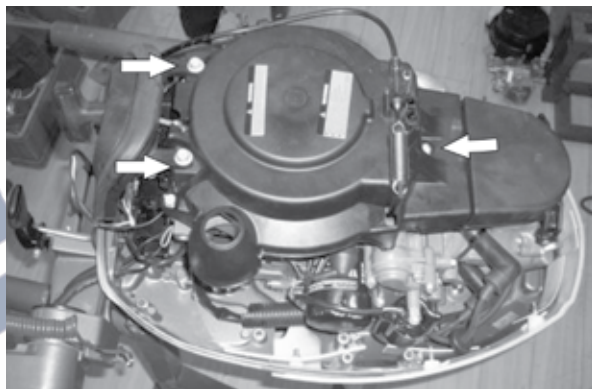

5. Place the starter rope knot into the starter cup notch and wind the rope clockwise around the cup.

6. Pull the rope slowly until resistance is felt.

7. Give a strong pull straight out to crank and start the engine. Repeat it necessary.

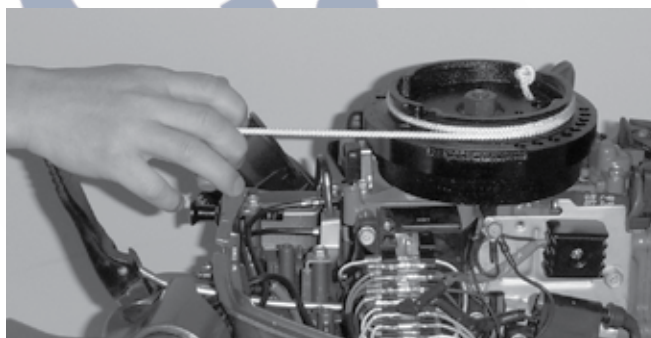

Treatment of submerged motor

If the outboard motor is submerged, immediately take it to a yours dealer. Otherwise some corrosion may begin almost immediate.

If you cannot immediately take the outboard motor to a yours dealer, follow the procedure below in order to minimize engine damage.

Procedure

1. Thoroughly wash away mud, salt, seaweed, and so on, with fresh water.
2. Remove the spark plug(s), then face the spark plug holes downward to allow any water, mud, or contaminants to drain.
3. Drain the fuel from the carburetor, fuel filter, and fuel line. Drain the engine oil completely.
4. Fill the sump with the fresh engine oil.

Engine oil capacity:
0.8L (0.85US qt)(0.70 Imp.qt)

5. Feed engine fogging oil or engine oil through the carburetor(s) and spark plug holes while cranking the engine with the manual starter or emergency starter rope.

6. Take the outboard motor to a yours dealer as soon as possible.

CAUTION

Do not attempt to run the outboard motor until it has been completely inspected.

Nautimarket

Marine Discount



HIDEA

HangZhou Hidea Power Machinery Co. , Ltd.

Nautimarket Srl - ITALY

www.hidea.ws

www.nautimarket.com