

Overlander PEV Power Wheelchair



Customer Manual

#8011

Uncontrolled Copy
Rev 7.0 Current 07/15/09



TABLE OF CONTENTS

DEFINITIONS OF SYMBOLS	1
INTRODUCTION	
Description	3
Specifications	4
PRE-USE INSPECTION AND SET UP	
Safety Checklist	5
Battery Installation and Removal	5
OPERATION OF MECHANISM	
General	8
Center of Balance	8
Curbs and Single Steps	8
Doorways and Obstacles	9
Escalators	9
Motor Vehicle Safety	9
Reaching or Leaning	9
Slopes	10
Street and Roadways	11
Transfers	11
Transporting a Chair and Rider Up or Down Stairs	12
FEATURES	
Anti-Tip Device	13
Armrest	13
Batteries	13
Control System	14
Drive Motors	17
Electric Wheel Lock Release	17
Electrical Components	18
Footrest	18
Manual Wheel Locks	19
Pneumatic Tires	20
Positioning Belts	20
Upholstery Fabric	20
OPTIONS	
Armrest	21
Elevating Footrest	21
Headrest	23
Seating System Modifications	23

TABLE OF CONTENTS

SAFETY TIPS

Cleaning	24
Control System Care	24
Electromagnetic Interference (EMI)	24
Fasteners	26
Maintenance	26
Storage	27

WARRANTY INFORMATION

Limitations and Exclusions	28
Governing Law	28
Warranty Services Procedures	29

MANUFACTURER DISCLAIMER

General Information	30
Trademarks and Patents	30
Copyright	30

DEFINITIONS OF SYMBOLS

DEFINITIONS OF SYMBOLS

In the following sections you will find important instructions for your safety. The words “WARNING” and “CAUTION” alert you to specific risk of personal injury or property damage. They mean as follows:

 **WARNING** A hazard or unsafe practice that may cause severe injury or death to you or to other persons.

 **CAUTION** A hazard or unsafe practice that may cause damage to this bed or to other property.

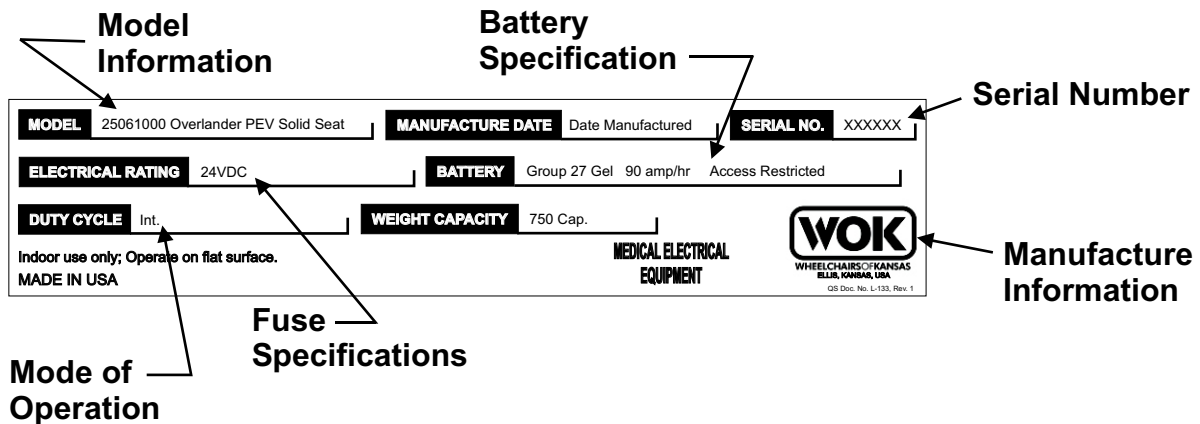

INTRODUCTION

You should make sure that persons who assist you read and follow all warnings and instructions that apply to that use. Before using this powerchair, each attendant must know what to do to ensure safety.

⚠ WARNING If you fail to heed these warnings, severe injury may occur to you or your attendant.

1. Put the user at ease. Tell the user what you plan to do and explain what you expect the user to do.
2. Work with the user doctor, nurse or therapist to learn safe methods best suited to your abilities and those of the user.
3. Always use good posture and proper body mechanics. When you lift or support the user, bend your knees slightly and keep your back as upright and straight as you can.

DESCRIPTION

The Overlander PEV from Wheelchairs of Kansas offers dynamic performances for the bariatric individual. It meets the mobility needs of the individual with rugged tires, a durable steel frame for strength and the power of two 4-pole motors. The suspension is adjustable allowing for fine-tuning of the individual rider. The gear belt drive system and 4-ply tires virtually create an all terrain powerchairs. The PEV's seating system can have a customized seating system or a captain's chair. The captain's chair can not be customized and comes as is. The customized seating system can individualized in the width, depth, and back height.

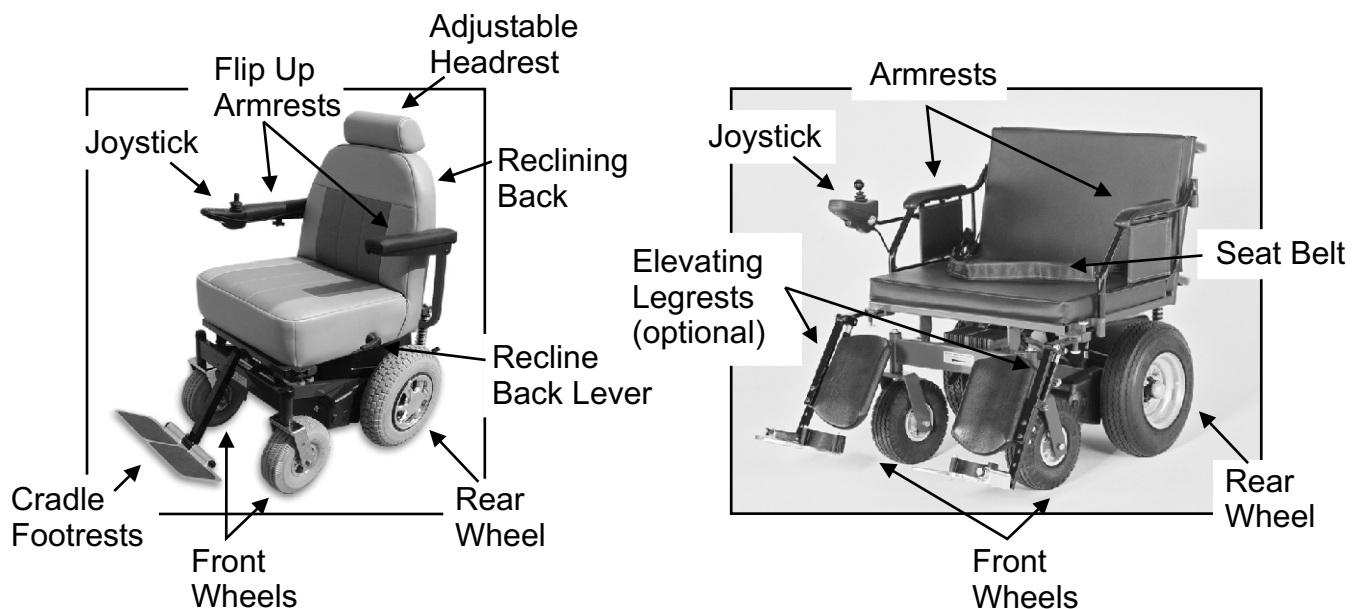

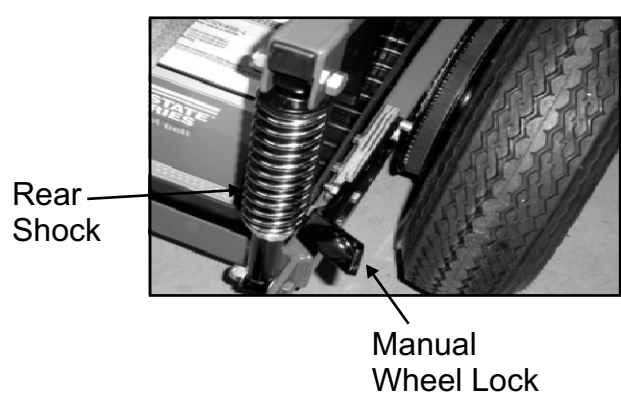
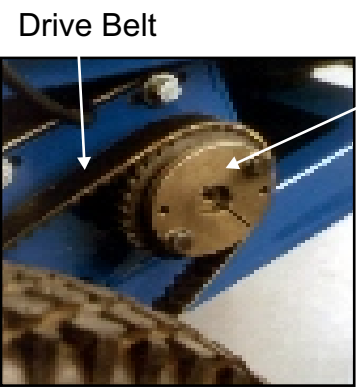
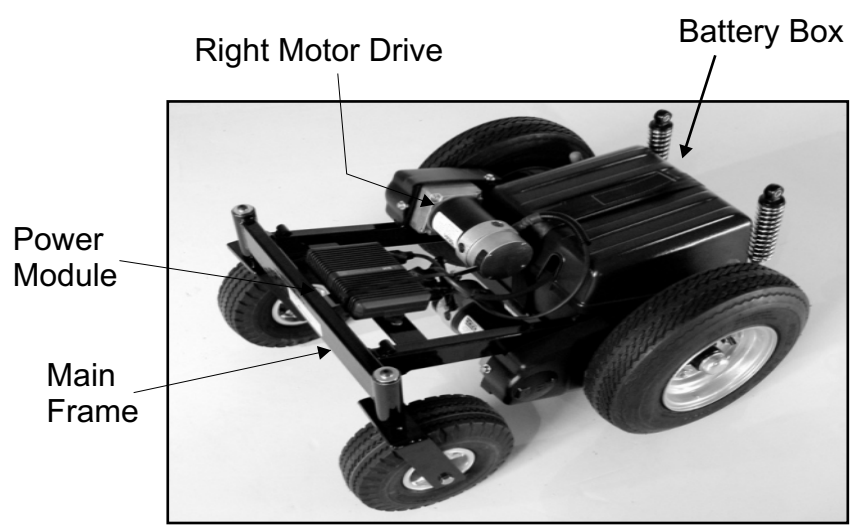

INTRODUCTION

SPECIFICATIONS

CUSTOMIZED SEATING SYSTEM

Overall Width - 18" - 24"	29.5"
24"	30"
26"	32.5"
28"	34.75"
Overall Depth	35"
Overall Height - 19"-20"	19"-20"
21"-22"	21"-22"
Seat Depth	18"-24"
Seat Height - 19"-20"	19"-20"
21"-22"	21"-22"
Back Height.	16"-24"

CAPTAIN'S CHAIR

Overall Width.	28.5"-35.5"
	<small>DEPENDING ON ARMREST & JOYSTICK PLACEMENT</small>
Overall Depth.	35"
Overall Height - Floor to Top of Back	41"
Floor to Top of Headrest	46"
Seat Width	25"
Seat Depth.	21"
Seat Height from Floor	24"
Back Height - Back height.	20"
Including Headrest	24.5"
Seat Thickness	5"
Maximum Recline	40"

BOTH UNITS

Weight of Unit With Battery	385 lb.
Weight of Unit Without Battery.	285 lb.
Battery Power	2 - Group 27 Gel
Battery Range.	Varies (depending on weight in chair & terrain)
Minimum Turning Radius.	41"
Maximum slope or incline	10 degrees
Weight Capacity.	750 lb.
(Exceeding this limit will void the warranty)	



WARNING

If you fail to heed this warning, a fall may occur and cause severe injury to you or your attendant, and may cause damage to this wheelchair and to other property.

PRE-USE INSPECTION AND SETUP

SAFETY CHECKLIST

⚠ WARNING If you fail to heed these warnings, severe injury may occur to you or others. Before each use of your wheelchair you should:

1. Make sure all packing material is removed.
2. Check each connection to make sure all wires are secure after shipping.
3. Be sure batteries are fully charged before you operate the wheelchair.
4. Check that the anti-tip devices are not damaged. **DO NOT OPERATE THIS WHEELCHAIR WITHOUT THEM PROPERLY INSTALLED.**
5. Install footrest/elevating legrests and armrests (including the joystick) before operating.
6. Make sure that your chair rolls easily and freely and that all parts work smoothly.
7. Check for excess noise, vibration or a change in ease of use. They may be signs of a problem such as low tire pressure, loose fasteners or damage to the chair.
8. If you detect a problem, make sure to repair or adjust your chair before using it. Contact your authorized Wheelchairs of Kansas dealer to help you find and correct the problem.

BATTERY INSTALLATION & REMOVAL

⚠ WARNINGS If you fail to heed these warnings, improper installation may cause personal injury or property damage if instructions are not followed.

Tools Required:

5/8" Wrench

7/16" Wrench

To install the batteries in the PEV, follow these steps in order. To remove the batteries, follow these steps in reverse order. If you have any questions regarding these instructions, please contact 800-537-6454.

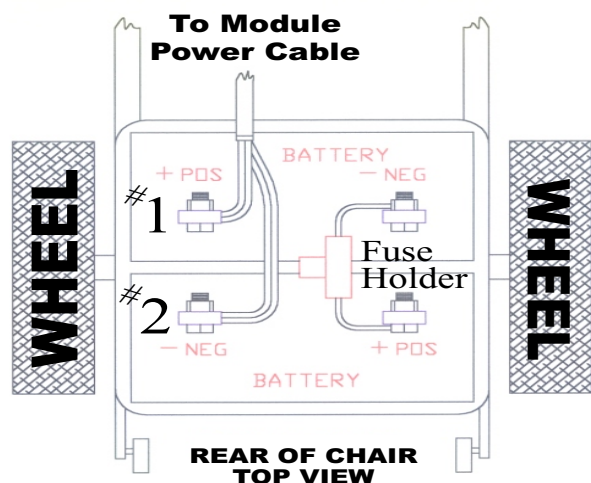

PRE-USE INSPECTION AND SETUP

1. At the rear of the chair, there are two shocks. Remove the top bolts on both shocks, with a 5/8" wrench.

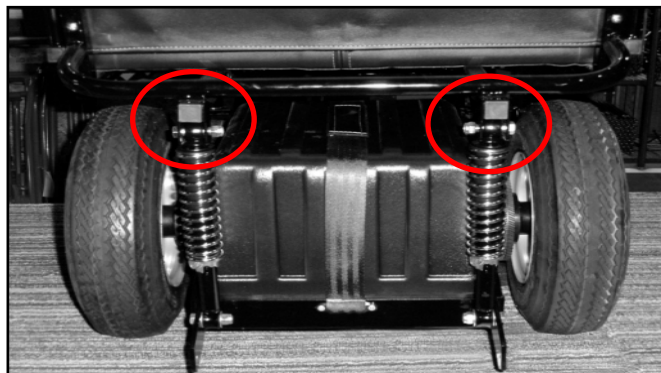

2. Undo velcro that is holding the top of the battery box on.



3. Lift seating system up. The front of the seating system will remain attached.



4. Disconnect wiring harness from the control module.



PRE-USE INSPECTION AND SETUP

5. Remove battery box top.



6. With a 7/16" wrench disconnect the black (negative) wire and the red (positive) wire from each of the batteries on the left side.

⚠ WARNING Electric Shock Hazard. Do not let wires cross.

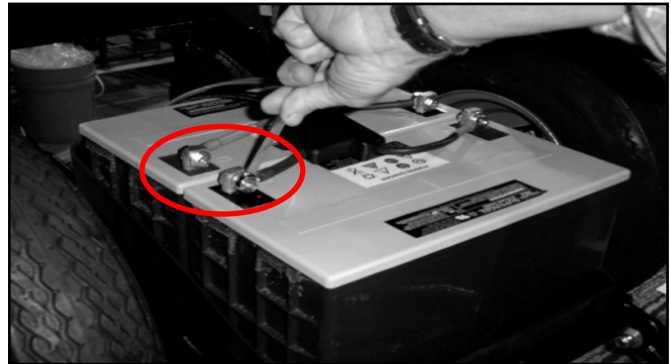

7. With a 7/16" wrench disconnect the red (positive) wire and the black (negative) wire from each of the batteries on the right side.

⚠ WARNING Electric Shock Hazard. Do not let wires cross.

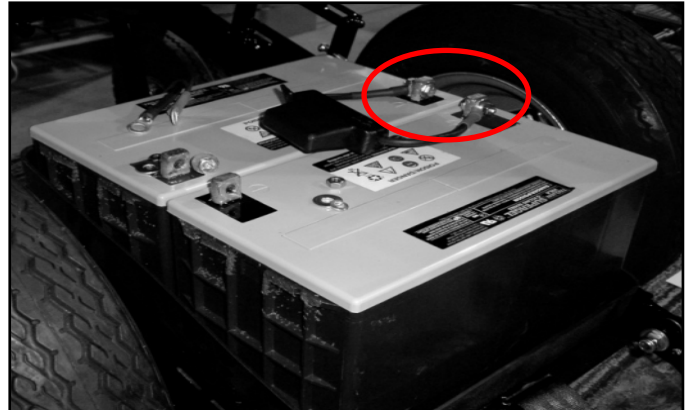

8. Remove Batteries.

⚠ WARNING Each battery weighs approximately 60 lbs.

Place hardware in battery box and replace battery box lid for transport. Reattach velcro that is holding the top of the battery box on.



OPERATION OF MECHANISM

GENERAL



WARNING

If you fail to heed these warnings, a fall or tip over may occur and cause severe injury to you:

1. Start off slowly. If you are not familiar with the maneuverability of this wheelchair you may lose control and tip over.
2. Have someone help you until you know what can cause a tip over and how to avoid doing so. Never try a new maneuver on your own until you are sure you can do it safely.
3. Your chair is most stable when you are moving forward. Be very careful when you move your wheelchair backward. You may lose control or tip over if one of the rear wheels hits an object and stops rolling.

CENTER OF BALANCE



WARNINGS

The point where the chair will tip forward, rearward or to the side depends on its center of balance and stability. If you fail to heed these warnings, a fall or tip over may occur and cause severe injury to you.

1. To avoid a fall or tip over, you should have someone help you until you know the balance points of your chair and how to avoid a tip over.
2. The center of balance and stability of your chair are affected by :
 - A. A shift in your body position, posture or weight distribution.
 - B. Riding your chair on a sloped surface.

CURBS AND SINGLE STEPS



WARNINGS

If you fail to heed these warnings, a fall or tip over may occur and cause severe injury to you or others:

1. The anti-tip devices are not removable and may interfere.
2. Do not try to climb or descend a curb or a step, more than 1 1/2 inches high. Whenever possible, seek a suitable ramp or access designed for electric wheelchairs.



CAUTION

The impact from dropping down from a curb or step can damage the frame or other chair parts and may loosen fasteners. Check for damage to the wheelchair or loose fasteners before each use.

OPERATION OF MECHANISM

DOORWAYS AND OBSTACLES

1. Make sure that the floor area where you use this chair is level and free of obstacles. You may need to:
 - A. Remove or cover threshold strips between doors.
 - B. Install a ramp at some doors.
2. To help correct the center of balance of your wheelchair you should:
 - A. Lean your upper body forward slightly as you go up over an obstacle.
 - B. Press your upper body backward as you go down from a higher to a lower level.

ESCALATORS



WARNING

Never take a chair on an escalator, even with an attendant. Doing so is likely to cause a fall or tip over and severe injury to you and others.

MOTOR VEHICLE SAFETY



WARNING

Wheelchairs of Kansas wheelchairs do not meet the federal standards for motor vehicle seating. If you fail to heed these warnings, the rider may suffer a severe injury:

1. Never permit anyone to sit in this wheelchair while he or she is in a moving vehicle. The rider may be thrown from the chair in an accident or sudden stop. Wheelchair positioning belts will not prevent this.
2. Always move the rider to an approved vehicle seat. Secure the rider with proper motor vehicle restraints.
3. Never transport this chair in the front seat of a vehicle. It may shift and interfere with the driver. Always secure this chair so that it cannot roll or shift.

REACHING OR LEANING

(Example: Dressing or Changing Clothes)



WARNINGS

Reaching or leaning affects the center of balance of your wheelchair. If you fail to heed these warnings, a fall or tip over may occur and cause severe injury to you:

OPERATION OF MECHANISM

1. Avoid reaching or leaning if you must shift your weight to do so. Ask for help or use a device to extend your reach.
2. Never try to reach an object if you must move forward in your seat to do so. This may cause the wheelchair to tip forward. Always keep your buttocks in contact with the backrest.
3. Never reach with both hands. If you do so, you may not be able to catch yourself to prevent a fall if the chair tips.
4. Never lean backward to reach an object.
5. If you must reach or lean from your chair:
 - A. Place your chair as close as you can to the object you wish to reach.
 - B. Avoid putting pressure on the footrests/elevating legrests while you reach. This may cause the chair to tip forward.



Put Front Casters
in Position Shown

SLOPES



WARNINGS Going up or down a slope will change the center of balance of your chair. If you fail to heed these warnings, you may suffer a severe injury from a tip over, fall or lose of control:

1. Lean or press your body uphill to help correct the change in the center of balance.
2. Avoid turning on a slope, as a tip over is likely. Always go as straight up and straight down as you can.
3. The power drive mechanism WAS NOT designed to climb a slope and/or incline greater than 10 degrees. (A 10% slope means: One foot of elevation for every ten feet in length of the slope.) Ask for help if the slope is greater than 10 degrees.
4. Controlling speed when going downhill:
 - A. The power drive mechanism was designed to maintain a safe speed while going down a 10 degree or less slope. Ask for help if the slope is greater than 10 degrees.
 - B. Never use the rear wheel locks to try to slow or stop your wheelchair. Doing so is likely to cause you to veer out of control or tip over.

STREETS AND ROADWAYS

⚠ WARNINGS In most states, wheelchairs are not legal for use on public roads. Be alert to the dangers of motor vehicle traffic on roads or in parking lots.

1. At night, or when lighting is poor, use reflective tape on your wheelchair and clothing to make it easier for drivers to see you.
2. Due to low position, it may be hard for drivers to see you. Make eye contact with drivers before you go forward. When in doubt, yield until you are sure it is safe.

TRANSFERS

⚠ WARNINGS If you fail to heed these warnings, a fall or tip over may occur and cause severe injury to you:

1. Transfers require good balance and agility and are very dangerous. Be aware that there is a point during each transfer when the chair seat is not below you.
2. Always lock the rear wheels before you transfer.
3. Locking the rear wheels will not keep your chair from sliding away from you or tipping. To avoid a fall, you should:
 - A. Learn how to position your body and how to support yourself during a transfer.
 - B. Work with your doctor, nurse or therapist to learn safe transfer methods.
 - C. Have someone help you until you are sure you can perform safe transfers on your own.
4. Rotate the front casters into position shown to make the chair more stable.
5. Be careful of the footrests. To avoid a trip or fall when you transfer, you should:
 - A. Make sure your feet do not “hang up” or get caught in the space between the footrests.
 - B. Avoid putting weight on the footrests as the chair may tip forwards.
 - C. If you can, remove or swing the footrests out of the way.
6. Removing armrest may be helpful.



Put Front Casters
in Position Shown

OPERATION OF MECHANISM

TRANSPORTING A CHAIR AND RIDER UP OR DOWN STAIRS



WARNING

Wheelchairs of Kansas does not endorse or recommend the lifting of the chair, with a person in it. Other means of transport must be used to carry a person over stairs or obstructions in the pathway if no ramp or other means is provided to properly roll the chair around or over the stairs or obstructions.

ANTI-TIP DEVICE



WARNING

The anti-tip devices are not designed to bear the weight of the wheelchair and rider. Failure to heed this warning when climbing or descending stairs, curbs, steps or other objects could result in damage to the wheelchair and cause the wheelchair to tip or fall causing severe injury to you or others.

ARMREST

The armrests are detachable. They are not designed to bear the weight of the wheelchair.



WARNING

Never try to lift the wheelchair by its armrest. They may come loose or break. If this occurs, the wheelchair may fall and cause severe injury to you or others. Lift the wheelchair only by non-detachable parts of the main frame.

BATTERIES

Never tamper with the batteries on this wheelchair.



WARNING

The type of batteries used on this wheelchair contain a highly corrosive acid. Never let the acid come in contact with yourself or any other object. If you fail to heed these warnings, you may suffer severe burns or other injury and/or cause damage to anything that comes into contact with the acid.

If the batteries become damaged, contact your authorized Wheelchairs of Kansas dealer immediately for replacement. Always read and follow battery manufacturer's directions.

Your PEV Powerchair could have either Gel batteries (sealed) or Lead Acid. You and your dealer, once having assessed your intended use of the powerchair, should make this choice. The primary difference between the two types are, lead acid holds approximately 20% more charge so they can go longer between charges. Lead acid can also be recharged in twice the time of a sealed battery. Lead acid batteries require periodic maintenance. If tipped over they can leak acid and need special handling if being transported by an airline.

Do not rely on the battery charger to tell whether or not the batteries are fully charged. Do not rely on the voltage indicator on the joystick to tell whether or not the batteries have been fully charged, or if the batteries can maintain a charge. Periodic inspection needs to be done with the proper test equipment and trained service personnel. It is normal for batteries to gradually wear down and require longer charging times. See maintenance section for additional care instructions of battery.

FEATURES

CHARGING THE BATTERY:

Connect the charger to the bottom side of the joystick, then connect to the wall outlet. **Always** connect the charger to the powerchair first, then connect to the wall outlet.

Always keep your powerchair fully charged. Connect the batteries to a charger every night and then disconnect them in the morning. A charging pattern of 12 to 14 hours on a charger and 12 to 14 hours off a charger will help to maintain strong fully charged batteries.

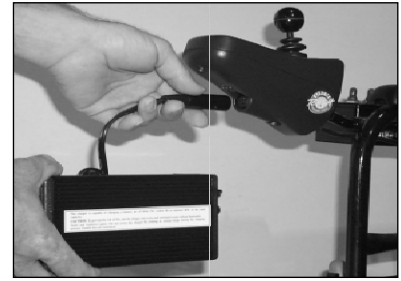

When charging Gel or sealed batteries, do not exceed a 8-amp charge rate. Doing so runs the risk of irreversible damage to the battery by causing it to split open or burst. The proper charger is shipped with the powerchair.

When charging lead acid batteries do not exceed a 12-amp charge rate. Doing so runs the risk of prematurely wearing out the batteries.

When charging is complete, disconnect the charger from the wall outlet first, then from the powerchair. **Always** disconnect the charger from the wall outlet first, then from the powerchair.

CONTROL SYSTEM

The information in this manual is a brief overview. See the VR2 Control System Manual for more details.



WARNING

The manufacturer of the VR2 and Wheelchairs of Kansas accepts no liability for losses of any kind arising from unexpected stopping of the powerchair or improper programming of the control system, improper use of the powerchair, improper use of the control system or if any of the criteria detailed in this document are not met.

The internal settings for the joystick and control module are preset at the factory for your safety to insure proper power and operation of the wheelchair. **Do not change any programmed functions without authorization from Wheelchairs of Kansas.** To do so will void any and all warranties.

Joystick: This controls the speed and direction of the wheelchair. Push the joystick in the direction you wish to go. The further you push it, the faster the speed. Releasing the joystick stops the wheelchair and automatically applies the brakes.

Charger and programmer Socket: Only connect a PGDT Programmer or the charger supplied with the wheelchair into this socket. The charger current must not exceed 12 Amps

and the charger must be fitted with a Neutrik NC3MX plug. This socket must not be used as a power supply for any other electrical device.

Power Module and Joystick Cable: The Power Module contains most of the electronics for controlling the wheelchair. It has three main connections to the batteries and each motor. The Joystick Cable links the Power Module to the Joystick Module. For further information refer to the wheelchair manufacturer's documentation.

Battery Gauge: This is a 10 segment display which indicates if the VR2 is switched on and gives the state of charge of the battery. Additionally, any faults in the wheelchair's electrical system are indicated by this display. Refer to the wheelchair's documentation for more details.

On/Off Button: This button turns the VR2 on and off. Do not use this button to stop the wheelchair, except in an emergency.

Horn Button: This button operates the wheelchair's horn.

Speed/Profile Decrease Button: This button decreases the maximum speed setting or selects a lower drive profile.



Maximum Speed / Profile Indicator: This is a 5 segment display which indicates the maximum speed setting or which drive profile is selected. The wheelchair's documentation will state whether the VR2 is set up for maximum speed or drive profile operation.

Speed/Profile Increase Button: This button increases the maximum speed setting or selects a higher drive profile.

Actuator button and LED: If the wheelchair is fitted with actuators, this button(s) will enter and exit actuator adjustment mode. When in actuator adjustment mode, the LED will be illuminated.

Daily Checks

Joystick: With the control system switched off, check that the joystick is not bent or damaged and that it returns to center when you release it. If there is a problem do not use your wheelchair and contact your dealer.

FEATURES

Cables: Check condition of all cables for damage.

Joystick Gaiter: Check the thin rubber gaiter around the base of the joystick for damage or splitting. Check visually only, do not handle the gaiter.

Mounting: Make sure the controller is securely fixed to your wheelchair. Do not over tighten any screws.

Weekly Checks

Electrical Brakes: This test should be carried out on a level floor with at least one meter clear space around the wheelchair.

Check that after 1 second the battery gauge remains on or flashes slowly.

Push the joystick slowly forwards until you hear the electrical brakes operate. The chair may start to move.

Immediately release the joystick, you must be able to hear each electrical brake operate within a few seconds.

Repeat the test three times, pushing the joystick backwards, left and right respectively.

If your wheelchair is fitted with lights, turn indicators or seat adjustment actuator, check the operation of these.

Precautions For Use

The VR2 control system has been designed with the user's safety as the prime consideration. It incorporates many sophisticated self-test features which search for potential problems at a cycle of 100 times per second. If the control system detects a problem either in its own circuits, or in the wheelchair's electrical system, it may decide to halt the wheelchair depending on the severity of the problem. The VR2 is designed to maximize the user's safety under all normal conditions.

In spite of its sophistication, the VR2 cannot take into account circumstances which put the wheelchair and/or the controller outside of their specified operation conditions, and so it is important that the user follows the precautions below:

1. Do not drive the wheelchair:
 - A. Beyond restrictions indicated in the wheelchair user manual, for example maximum inclines, curb height etc.

- B. In places or on surfaces where a loss of wheel grip could be hazardous, for example on wet grassy slopes.
 - C. If the controller of other crucial components are known to require repair. In the event of the wheelchair moving in an unexpected way **RELEASE THE JOYSTICK**. This action will stop the wheelchair under any circumstances.
2. Although the VR2 control system is designed and manufactured to be extremely reliable and each unit is rigorously tested, a system malfunction is always a possibility (however with a small probability). Under some conditions the system may detect a malfunction, the controller will (for safety reasons) stop the chair instantaneously. If the physical impairments of the user are such that a sudden braking action could result in a fall from the chair, it is imperative that a restraining device such as a seat belt be purchased and installed with the chair. Restraining devices should be used at all times when the wheelchair is in motion.

DRIVE MOTORS

Note: The motors are equipped with an internal parking brake.

The PEV incorporates two 4-pole 24 VDC, high torque motors with automatic braking and manual release. The brakes engage within two seconds of the joystick being placed in the neutral position. The brakes will release immediately when the joystick is moved in any direction.

When the power on the wheelchair is turned off (the controller turned off), the electric lock brakes can be released manually by moving the release lever on the front of the chair. When lever is in this position the chair is able to move freely without the use of the motors. **As a safety precaution, the wheelchair will not operate when the brake is being held in the manual release position.**

ELECTRIC WHEEL LOCK RELEASE

Move the lever to the left (when facing) to disengage and right (when facing) to engage.

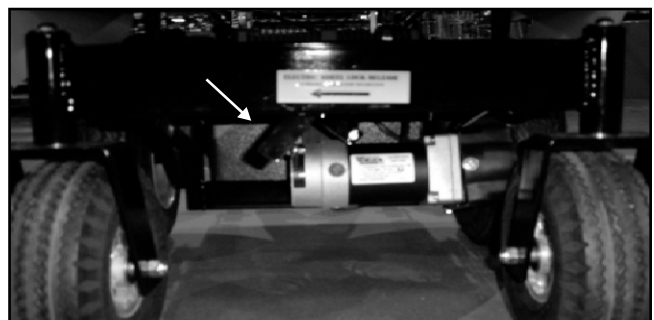

FEATURES

ELECTRICAL COMPONENTS

Never allow the electrical components to become wet.

-  **WARNING** The electrical components of this wheelchair are not designed to be moisture proof. If you allow these components to become wet, you could suffer an electrical shock and/or cause severe damage to the components.

FOOTRESTS

The footrests are detachable. **They are not designed to bear the weight of this wheelchair.**

-  **WARNING** Never try to lift the wheelchair by its footrests/elevating legrest. They may come loose or break. If this occurs, the wheelchair may fall and cause severe injury to you or others. Lift the wheelchair only by parts that do not detach from the main frame.

If you fail to heed these warnings, a fall or tip over may occur and cause severe injury to you:

The lowest point of the footrests should be at least 2-1/2 inches above the ground level on a flat surface. If set too low, they may “hang up” on the types of obstacles you can expect to find in normal use. This may cause the wheelchair to stop suddenly and tip forward. To Remove:

1. Pull up on the pin located at the top of the footrest.

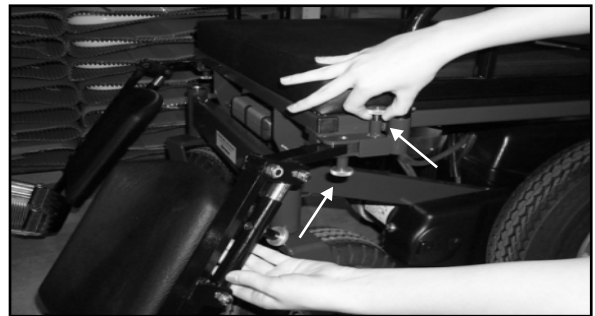

2. Using your other hand, swing the footrest outward. Pull down pin and continue to pull out the footrest.



To Adjust Height:

Remove the two bolts located near the bottom of the footrest. Slide the footrest up or down to the desired height, then replace the two bolts in the correct aligning holes.



MANUAL WHEEL LOCKS



WARNING

The chair will not operate with manual wheel locks engaged. The manual wheel locks are independent of the electric wheel locks, the Overlander also has on each wheel an additional manual locking mechanism. This system locks up the actual drive at the rear wheel hub and so works regardless of tire condition for greater safety. Manual wheel locks are not designed to slow or stop a moving wheelchair. Use them only to keep the rear wheels from turning when the chair is at a complete stop (such as, during transport). If you fail to heed this warning, you may suffer a severe injury from a tip over, fall or loss of control. For safety purpose, disengage electric wheel lock when engaging manual wheel locks. The manual wheel locks are accessed at the rear of the wheelchair.

When engaging the manual wheel locks, be sure to lock both sides. The locks are located on the inside of each rear tire.

To engage the manual wheel lock, pull down the black lever located to the inside of each tire. This locks up the actual drive at the rear wheel hub, so it works regardless of tire condition.

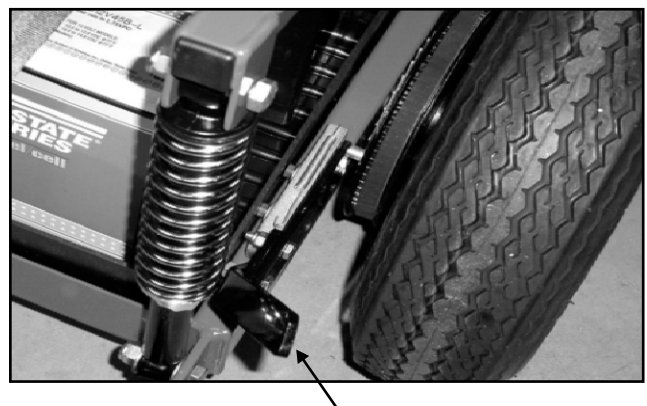

FEATURES

PNEUMATIC TIRES

Proper inflation extends the life of your tires and makes your wheelchair easier to operate.

1. Do not use this wheelchair if any of the tires are under or over inflated. Check weekly for proper inflation level, as listed on the tire sidewall.
2. Low pressure in any of the tires may cause the chair to veer to one side and may result in loss of control.
3. Over inflated tires may burst.

POSITIONING BELTS

Use positioning belts only to help support the rider's posture.

 **WARNING** **Improper use of positioning belts may cause severe injury or death of the rider.**

1. Make sure that the rider does not slide down in the wheelchair seat. If this occurs, the rider may suffer chest compression or suffocate due to pressure from the belts.
2. The belts must be snug, but must not be so tight that they interfere with breathing. You should be able to slide your open hand, flat, between the belt and the rider.
3. A pelvic wedge or similar device can help the rider from sliding down in the seat. Consult with the rider's doctor, nurse or therapist to find out if the rider needs such a device.
4. Use positioning belts only with a cooperative rider. Make sure that the rider can easily remove the belts in an emergency.
5. Never use positioning belts:
 - A. As a patient restraint. A restraint requires a doctor's order.
 - B. On a rider who is comatose or agitate.

UPHOLSTERY FABRIC

 **WARNING** **Replace worn or torn fabric immediately. Failure to do so may result in a fall and severe injury to you.**

The standard upholstery features a breathable 100% nylon fabric. The material is urethane coated for water resistance. The nylon fabric consists of 210 Denier which is soft, with low shear properties. The upholstery makeup provides durability for our products.

ARMREST

The armrests are detachable. They are not designed to bear the weight of the wheelchair.

⚠ WARNING Never try to lift the wheelchair by its armrest. They may come loose or break. If this occurs, the wheelchair may fall and cause severe injury to you or others. Lift the wheelchair only by non-detachable parts of the main frame.

Adjustable height armrests are optional. To adjust the height, hold down the pin located on the inner part of the armrest. Pull the armrest up to the desired height, then release the pin back into the aligning hole of the armrest.



ELEVATING LEGRESTS

The legrests are detachable. They are not designed to bear the weight of this wheelchair.

⚠ WARNING Never try to lift the wheelchair by its elevating legrest. They may come loose or break. If this occurs, the wheelchair may fall and cause severe injury to you or others. Lift the wheelchair only by parts that do not detach from the main frame.

If you fail to heed these warnings, a fall or tip over may occur and cause severe injury to you:

The lowest point of the legrest should be at least 2-1/2 inches above the ground level on a flat surface. If set too low, they may “hang up” on the types of obstacles you can expect to find in normal use. This may cause the wheelchair to stop suddenly and tip forward.

To Remove:

1. Pull up on the pin located at the top of the legrest.

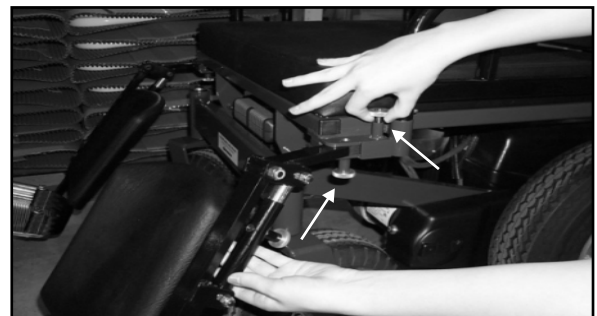

OPTIONS

- Using your other hand, swing the legrest outward. Pull down pin and continue to pull out the legrest.



To Adjust Height:

Remove the two bolts located near the bottom of the footrest. Slide the footrest up or down to the desired height, then replace the two bolts in the correct aligning holes.

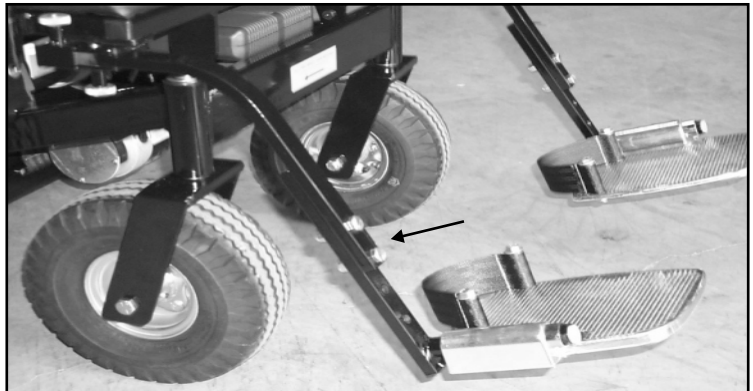

To Elevate:

Pull out the pin located on the underside of the legrest. With your other hand, move the legrest up or down to one of the five height settings. Return the pin into the new aligning holes.



HEADREST

Adjustable Headrest

Height Adjustment:

1. Loosen bottom knob on back of headrest and slide the headrest to the desired position.
2. Tighten the knob.

Depth Adjustment:

1. Loosen top knob on back of headrest and slide the headrest to the desired position.
2. Tighten the knob.

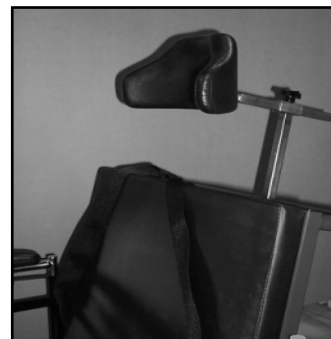

10" Headrest Extension

To Remove or Install:

1. Pull pins 2-places and pull headrest up to remove.
2. Reverse order to install.

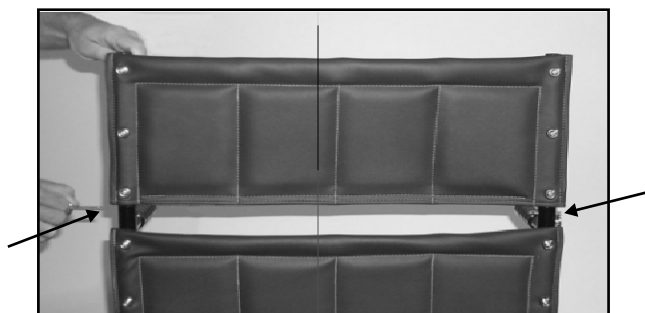

SEATING SYSTEM MODIFICATIONS



WARNING

Use of a seating system not approved by Wheelchairs of Kansas may alter the center of balance of the wheelchair. This may cause the wheelchair to tip over and result in severe injury to you. Do not make a change to the seating system of your wheelchair unless you consult your authorized Wheelchairs of Kansas dealer first.

SAFETY TIPS

CLEANING

Periodic cleaning of the frame and upholstery is recommended. Hand wash with a non-abrasive cleaner and drip dry or wipe dry with a soft cloth. Do not put upholstery in a dryer. The frame may be polished with a non-abrasive automotive wax.

Do not get electrical components wet.

CONTROL SYSTEM CARE

Avoid knocking your control system, especially the joystick.

When transporting your wheelchair ensure the control system is well protected.

To prolong the life of the control system, keep exposure to extreme conditions to a minimum. Always clean your control system if it becomes contaminated with food or drink.

Use a damp cloth and washing with liquid mixed with water. Do not use abrasive or spirit based cleaning agents.

ELECTROMAGNETIC INTERFERENCE (EMI)



WARNING

Radio wave sources, such as radio stations, TV stations, amateur radio (HAM) transmitters, two-way radios, and cellular phones, can affect powered wheelchairs. Following the warnings listed below should reduce the chance of unintended brake release or powered wheelchair movement which could result in serious injury.

1. Do not turn ON hand-held personal communication devices, such as citizens band (CB) radios and cellular phones while the powered wheelchair is turned ON.
2. Be aware of nearby transmitters, such as radio or TV stations, and try to avoid coming close to them.
3. If unintended movement or brake release occurs, turn the powered wheelchair OFF as soon as it is safe.
4. Be aware that adding accessories or components, or modifying the powered wheelchair, may make it more susceptible to interference from radio wave sources (Note: There is no easy way to evaluate their effect on the overall immunity of the powered wheelchair).
5. Report all incidences of unintended movement or brake release to the powered wheelchair manufacturer, and note whether there is a radio wave source nearby.

Important Information

The EMI value of this device was tested to 20 volts per meter (V/m), although if any accessories are added the immunity level is unknown. (EUT tested February 2001)



CAUTION IT IS VERY IMPORTANT THAT YOU READ THIS INFORMATION REGARDING THE POSSIBLE EFFECTS OF ELECTROMAGNETIC INTERFERENCE ON YOUR POWERED WHEELCHAIR.

Electromagnetic Interference (EMI) From Radio Wave Sources

Powered wheelchairs may be susceptible to electromagnetic interference (EMI), which is interfering electromagnetic energy (EMI) emitted from sources such as radio stations, TV stations, amateur radio (HAM) transmitters, two-way radios, and cellular phones. The interference (from radio wave sources) can cause the powered wheelchair to release its brakes, move by itself, or move in unintended directions. It can also permanently damage the powered wheelchair's control system. The intensity of the interfering EMI energy can be measured in volts per meter (V/m). Each powered wheelchair can resist EMI up to a certain intensity. This is called its "immunity level". The higher the immunity level, the greater the protection. At this time, current technology is capable of achieving at least a 20 V/m immunity level, which would provide useful protection from the more common sources of radiated EMI. This powered wheelchair model as shipped, with no further modification. The immunity level of this product is not known.

There are a number of sources of relatively intense electromagnetic fields in the everyday environment. Some of these sources are obvious and easy to avoid. Others are not apparent and exposure is unavoidable. However, we believe that by following the warnings listed below, your risk to EMI will be minimized. The sources of radiated EMI can be broadly classified into three types:

1. Hand-held portable transceivers (transmitters-receivers) with the antenna mounted directly on the transmitting unit. Examples include citizens band (CB) radios, "walkie talkies", security, fire, and police transceivers, cellular telephones and other personal communication devices.
NOTE: Some cellular telephones and similar devices transmit signals while they are ON, even when not being used.
2. Medium-range mobile transceivers, such as those used in police cars, fire trucks, ambulances, and taxis. These usually have the antenna mounted on the outside of the vehicle.
3. Long-range transmitters and transceivers, such as commercial broadcast transmitters (radio and TV broadcast antenna towers) and amateur (HAM) radios.
NOTE: Other types of hand-held devices, such as cordless phones, laptop computers, AM/FM radios, TV sets, CD players and cassette players, and small appliances, such as electric shavers and hair dryers, so far as we know, are not likely to cause EMI problems to your powered wheelchair.

SAFETY TIPS

FASTENERS



WARNINGS Many of the screws and bolts used in your wheelchair are special high-strength fasteners. If you fail to heed these warnings, a fall may occur and cause severe injury to you:

1. Improper fasteners may fail. Use only screws and bolts provided by an authorized Wheelchairs of Kansas dealer.
2. If screws or bolts become loose, tighten them as soon as possible.

MAINTENANCE



WARNING Your wheelchair requires regular maintenance to maintain performance and avoid premature wear, damage and injury.

You should check the items on this chart at the indicated intervals. If any or the items are loose, worn, bent or distorted, immediately have them checked and/or repaired by your authorized Wheelchairs of Kansas dealer. Frequent maintenance and servicing will improve performance and extend wheelchair life.

	Three Months	Six Months	Annually
Armrest		✓	
Drive Train	✓		
Fasteners	✓		
Frame	✓		
Upholstery		✓	
Wheels & Tires	✓		
Wheels Locks	✓		
Electrical Components	✓		
Batteries	✓	✓	✓
Headrest		✓	
Legrest		✓	
Dealer Inspection			✓

Batteries may take additional maintenance, such as visual inspection every three months. When inspecting batteries look for any corrosion, leaking or bulging. Batteries should be replaced after 18 months or sooner, depending on the care and usage.

The battery may require recycling in accordance with local laws. Contact your local recycling center for proper battery disposal or local regulatory authorities for more information.



WARNING Never dispose of batteries in a fire because they may explode.

TIRE PRESSURE

Check weekly for proper inflation level, as listed on the tire side wall.

STORAGE

Your wheelchair should be stored in a dry location so that the components do not rust. If your wheelchair is stored for any period of time, remove the batteries and charge them once a week. When bringing the wheelchair back into use after storage make sure it is adjusted properly and that all components are in working order before operating.

WARRANTY INFORMATION

<u>PRODUCT</u>	<u>WEIGHT CAPACITY</u>	<u>WARRANTY</u>
Overlander/PEV	750 lbs.	Five year warranty on frame; One year on all other components.

LIMITATIONS AND EXCLUSIONS

1. Products which have been used for purposes other than the intended uses; or which have been subject to negligence, abuse, improper storage or handling, improper operation, unauthorized modifications or damages beyond normal wear and tear as determined by Wheelchairs of Kansas are not covered by this warranty.
2. If weight capacity on any such product is exceeded, the warranty will be void. Any unauthorized repairs to product/part, as well as tampering with any components, will void the warranty.
3. Parts or materials which are subject to normal wear resulting from the use of these products and which must be replaced/repared due to such normal wear, are the owner's responsibility and are not covered by this warranty.
4. This warranty is exclusive and in lieu of all other express warranties, implied warranties, including but not limited to the implied warranty of merchantability and fitness for a particular purpose, and shall not extend beyond the duration of this warranty. Wheelchairs of Kansas shall not be liable for any consequential or incidental damages whatsoever.
5. This warranty applies to the purchaser only and is non-transferable. Invoice/shipping date is used as the start date for the warranty.
6. For warranty information in Canada please contact Canadian Medical Healthcare at 1-877-850-1330.

GOVERNING LAW

This purchase order and warranty shall be deemed executed in the county of Ellis, state of Kansas and the point of sale shall be deemed to be in the county of Ellis, state of Kansas. All disputes relating hereto shall be exclusively governed by, and construed in accordance with, the laws of the State of Kansas, without reference to its conflict of laws principles. Any legal action or proceeding relating to this purchase shall be instituted solely in a state of federal court in Ellis County, Kansas. Wheelchairs of Kansas and customer agree to submit to the jurisdiction of, and agree that venue is proper in, these courts in any such legal action or proceeding.

WARRANTY INFORMATION

WARRANTY SERVICES PROCEDURES

1. The product/part should be returned to the original selling dealer. To return the product/part to the factory the dealer must call to request authorization. At this time a return authorization number (RA#) will be issued. This RA# will be valid for 21 days from date issued. If the product/part is shipped to the factory without a RA # it will be refused.
2. Wheelchairs of Kansas products, with the exception of the bath/shower aids, are identified by a 6-digit serial number. Serial number identification is required for discussion of service. Removal or defacing this serial number may void all warranty.
3. For headboards and footboards with the beds, which are not covered under warranty, the customer will be responsible for shipping and return shipping costs. For all other products and parts, customers will not be responsible for shipping or return shipping costs for products and parts under this warranty returned within thirty (30) days of receipt; 31 - 60 days, customer will be responsible for shipping costs to Wheelchairs of Kansas; 61 days or more, customer will be responsible for shipping and return shipping costs.
4. If the problem is a result of defective material or workmanship, the product/part will be replaced or repaired at the discretion of Wheelchairs of Kansas, at no charge to the customer.
5. For replacement or repair of a product/part not covered under this warranty or if warranty is void the following applies: labor charges (minimum of \$45/hour; minimum of 1 hour) incurred and freight or delivery charges will be billed to the customer.

NOTE: Wheelchairs of Kansas will only pay regular ground freight on warranty product/parts.

MANUFACTURER DISCLAIMER

GENERAL INFORMATION

All specifications, equipment and prices are subject to change without notice. Wheelchairs of Kansas reserves the right to make improvements from time to time. Photos and drawings are representative of the products and may vary slightly from actual production models. Some items photographed in this brochure may include optional equipment. Contact or consult with your dealer to ensure proper equipment sizes, specifications and options.

Distributor is responsible for translation of this manual.

TRADEMARKS AND PATENTS

BCW and Wheelchairs of Kansas are registered trademarks of Raye's Inc.

COPYRIGHT

Copyright © 2004 by Raye's Inc.
dba Wheelchairs of Kansas
All rights reserved.

No part of the contents of this book may be reproduced, stored in a retrieval system or transmitted in any form or by any means, electronic, mechanical, photocopying, recording or otherwise, without the written permission of Raye's Inc.



WHEELCHAIRS OF KANSAS

800-537-6454 785-726-4885
www.wheelchairsofkansas.com