

CATSTM User's Manual

Aug 1, 2000

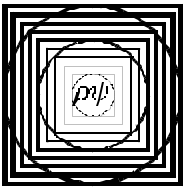

PRAGMATIC COMMUNICATIONS SYSTEMS, INC.

Table of Contents

Introduction

Description	3
Features	4

Installation 10

Rear Panel diagrams	11
IR detector / emitter	14
A/V connections	15
CAT5 cable	16
Power	17
IR remote	18

Operation 19

Router command set	21
Receiver/Transmitter command set	23

Appendix:

CAT 5 wiring	26
Troubleshooting Hints	27

Technology for Home Theater



The CATS™ system: *A very high performance broadcast quality audio/video distribution system on category 5 wires.*

Description

Pragmatic Communications Systems, Inc., proudly announces a new standard which overcomes the problems inherent with today's heavy gauge cables and traditional video distribution delivery systems. The CATS™ Audio/Video system is a very high performance system for the distribution of broadcast quality video signals on inexpensive category 3 or category 5 wires, based on PCSI's proprietary Bandwidth Domain Signal Processing (BDSP™) technology. This proprietary BDSP™ technology enables transmission of the highest quality audio/video signals up to 1000 ft. on a standard category 5 or un-shielded twisted pair wires without any loss in the performance, dynamic range, or quality.

The state-of-the-art BDSP™ technology completely eliminates any ground loops, noise pick-up, or hum at the end of the transmission distance. It also provides for superb video reproduction, and a very high resolution to fine details in the picture quality, achieved by the high bandwidth signal transmission.

The CATS™ A/V system is the ultimate in audio/video signal distribution. Up to 16 receivers can be daisy-chained or tapped on to the category 5 wires. The CATS™ system transmitter accepts audio/video signals from any high quality source, such as a DVD player or DSS receiver, and transmits it on the category 5 wires. The CATS™ system receiver recovers the signal from the category 5 wires and superbly reproduces the original audio/video signals utilizing the BDSP™ technology.

There are numerous advantages of the CATS™ system. First, it allows the multi-point distribution and broadcasting of video signals to any location within 1000 ft. on a category 5 wire. Up to 16 receivers can be connected in parallel or daisy-chained together on a single wire within the coverage area to provide a complete omnipresent network. The range can be extended to many miles or many receivers beyond 16 units by configuring a simple repeater system.

Another advantage is that there are no user adjustments or alignment needed, re-

ardless of the distance. The signal quality does not change with distance. The receiver reproduces the same high quality audio/video output at any point along the transmission distance. It is truly a plug-and-play system, with the added convenience of easy-to-use Category 5 wiring.

The applications of CATS™ are endless. It can be used for Home Theater audio/video distribution, broadcast TV video distribution, CCTV, perimeter monitoring, prison system, airport security, school campuses, hospitals, etc.

For most residential applications, the CATS™ system is supplied as a fully integrated system capable of handling both audio and video signals. For industrial or other special applications, the CATS™ system is also available as a CATS™ Video-only system, and a CATS™ Audio-only system.

The Model CATS™-8BY8TAV is a switcher/router for multi-source, multi-zone distribution of CATS™ signals to 8 different zones. Any input can be routed to any and all zones, independent of how the other zones are set. Each zone output can be daisy-chained to multiple CATS™ receivers and each zone driver is capable of driving 1000 ft. of category 5 cable. Programming and control is via serial (RS-232) input / output connection. Zone selection is also possible through remote control from the zones. The IR commands from the remote CATS™ receivers are interpreted by the switcher/router micro-controller and zone selection is achieved. Independent IR LED drivers are available for source equipment control.

Features

- Audio/Video distribution over low-cost un-shielded twisted pair wires
- Up to 1000 ft. distance (audio and video)
- Up to 5000 ft. distance (audio only)
- Up to 16 receivers for multi-point distribution
- CD-quality stereo audio signals
- > 6 MHz video bandwidth for high-resolution, DVD-quality video
- Receiver has option for volume up/down/mute control
- Optional IR control system controls receiver and remote sources
- Optional RS-232 or RS-485 interfaces available

Features (with switcher/router)

- 8 source inputs (from CATS™ transmitters)
- 8 zone outputs (to CATS™ receivers)
- Full-matrix switch to connect any input to any zone
- Router is easily controlled from remote locations via IR or other control system
- Compatible with standard home control systems: Crestron, Niles, Phast/AMX, SmartLinc, Xantech

Advantages

- Eliminates ground-loops, noise pickup, and hum
- DVD quality video reproduction
- Much higher quality than long-distance coax
- Uses low-cost, multi-function category 5 cable
- No adjustment or alignment necessary 0 to 1000 ft.
- Superior quality over multi-bundled coax and long runs of speaker cables
- Can use existing (or pre-wired) cables -- no need to run new cables!
- Each room can independently select any video and audio source

Applications

- Home Theater audio/video distribution
- Remote video extension to bedroom or den
- Send DVD, laser disc, VCR, or DSS output to remote rooms
- Broadcast studio video distribution
- Video extension for remote monitors
- CCTV and security video distribution
- Video delivery between buildings
- Remote camera video monitoring

Single-source, Multi-point A/V distribution

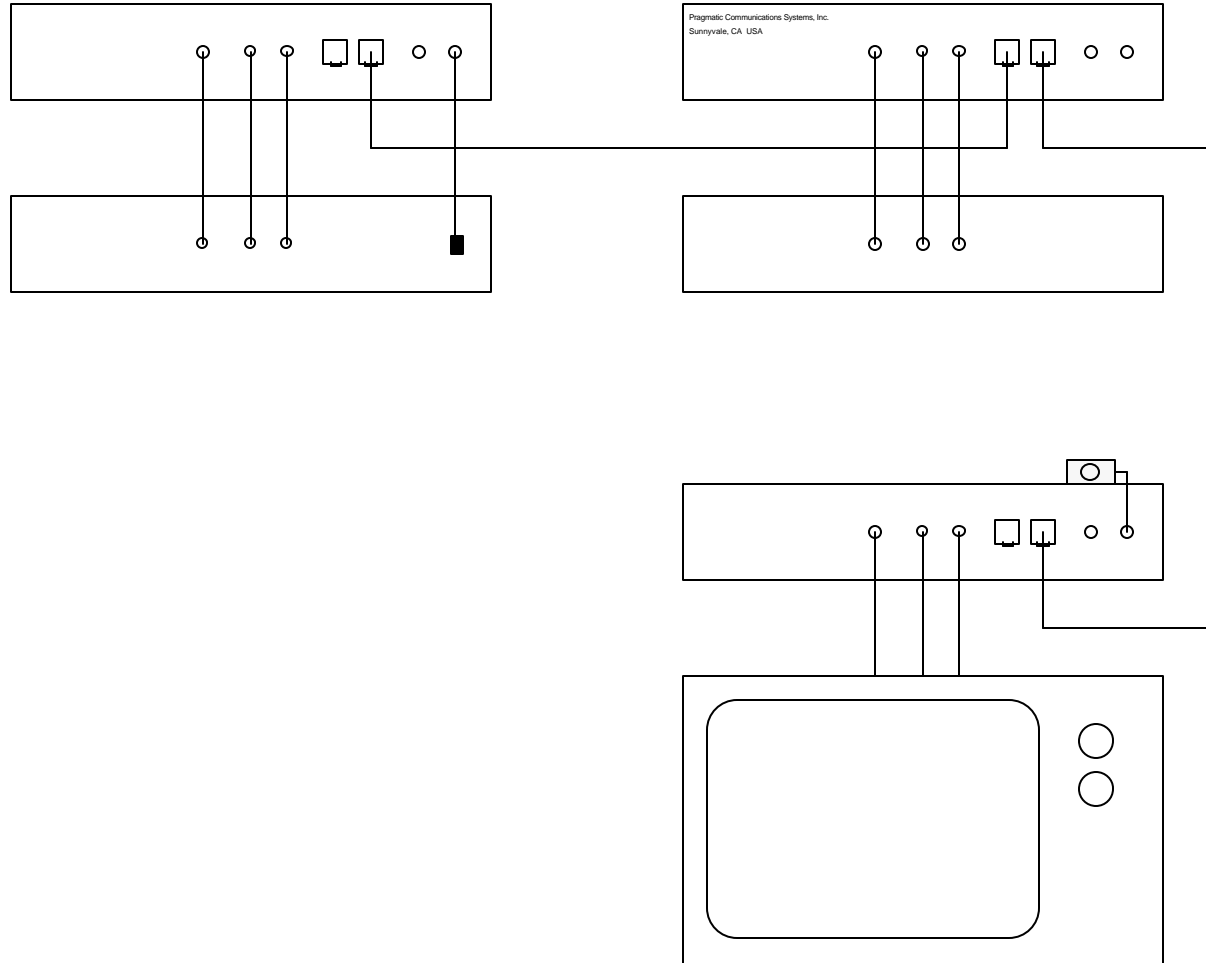

This example shows a single A/V source being distributed to one or more destinations. The A/V source could be a DSS receiver, DVD player, CD player, security camera, or any other A/V source. At each destination, the CATSTM receiver decodes the signals from the CAT 5 cable, and provides audio/video outputs for the user. If multiple receivers are being used, they are easily daisy-chained together.

Multi-source, Multi-zone A/V distribution

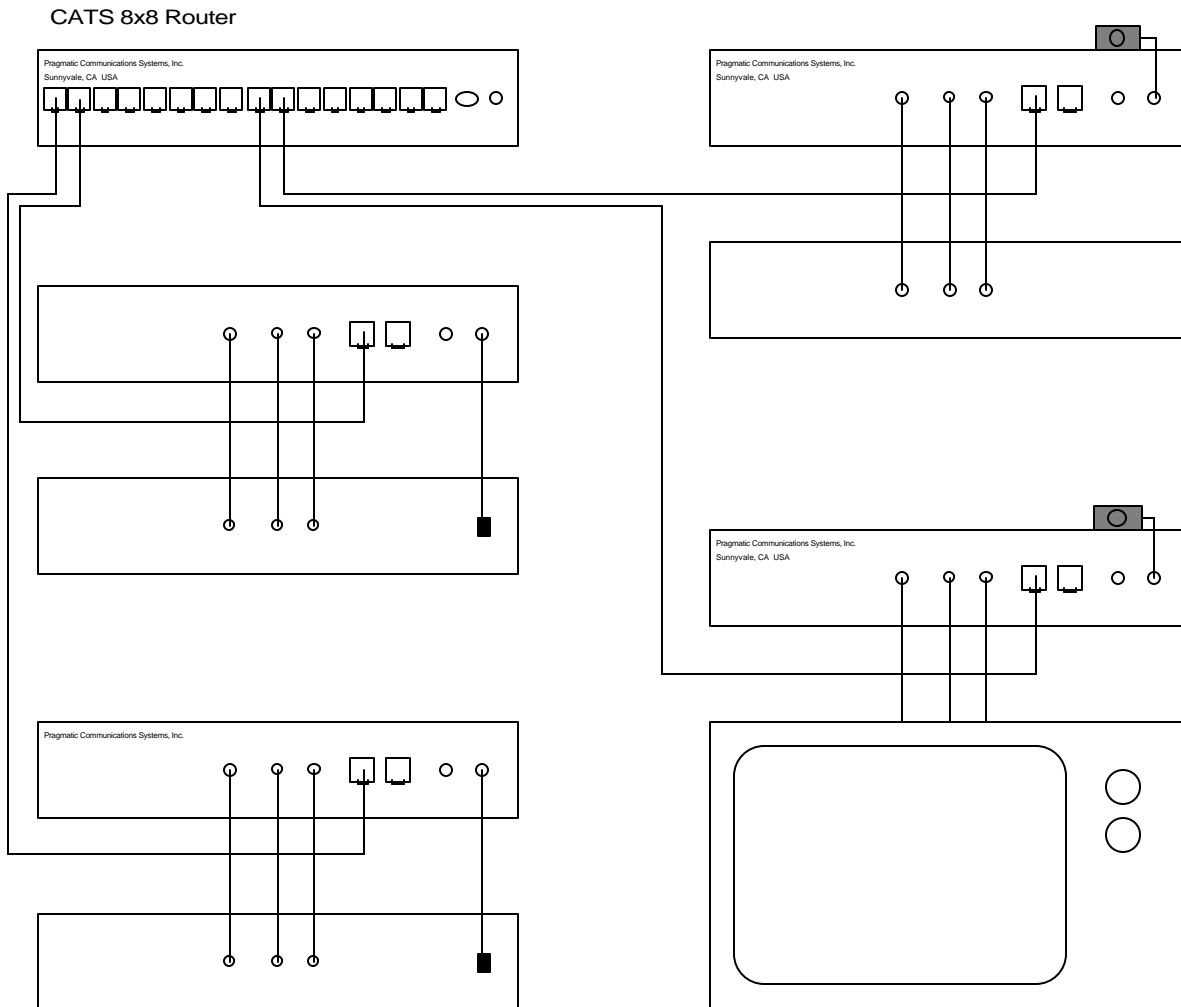

This example shows multiple A/V sources being distributed to one or more destinations through the CATS™ 8x8 router. Each A/V source could be a DSS receiver, DVD player, CD player, security camera, or any other A/V source. At each destination, the CATS™ receiver decodes the signals from the CAT 5 cable, and provides audio/video outputs for the user. The IR control system provides full control of the router and the source equipment from the remote location. Although this drawing only shows two sources and two zones, the router is capable of handling up to 8 sources and up to 8 zones.

Transmitter with local source inputs

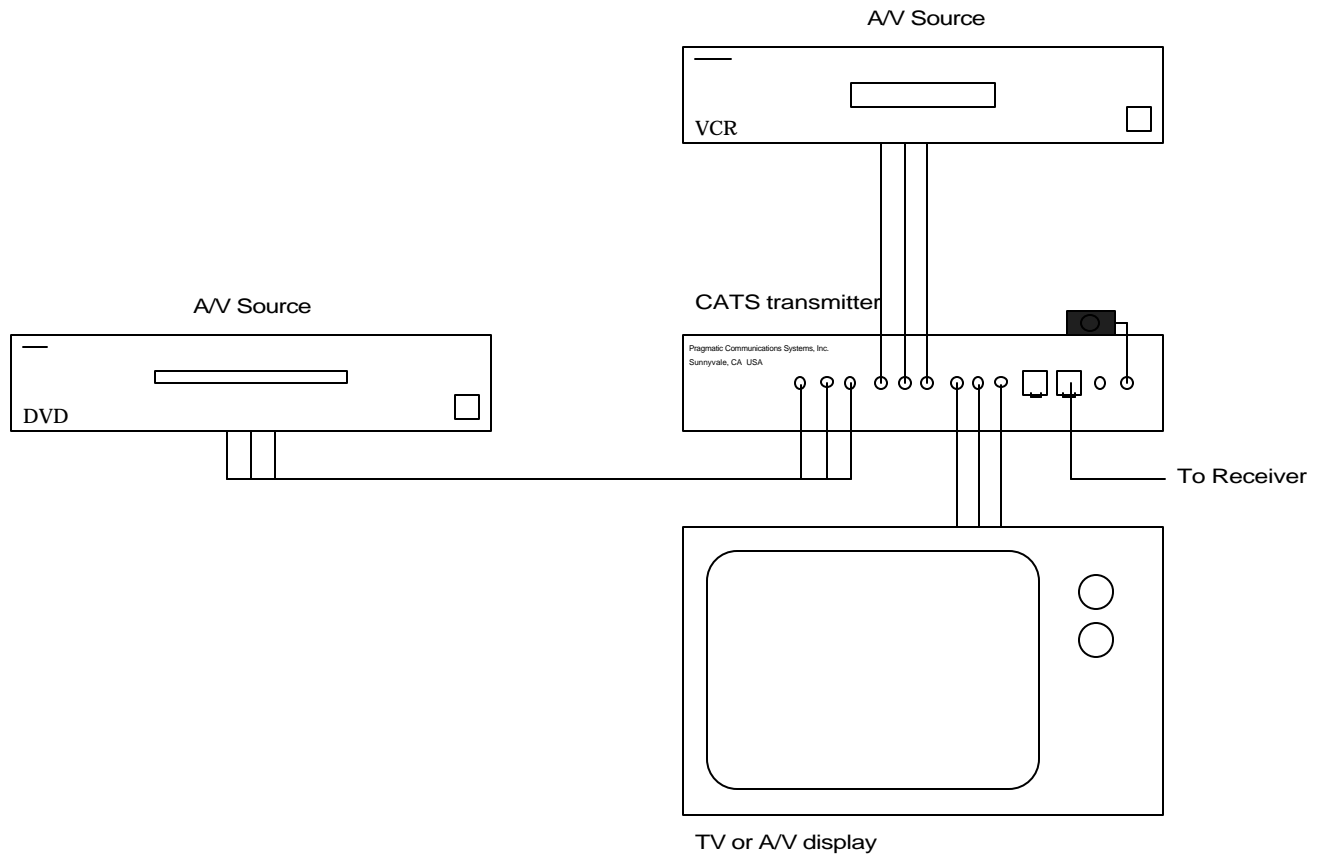

This example shows a CATS™ transmitter, with two local inputs, and one local output. The local output may select between either of the two inputs. The remote receiver may select between either of the two inputs as well, independent of which input has been selected for the local display.

Receiver with local source inputs

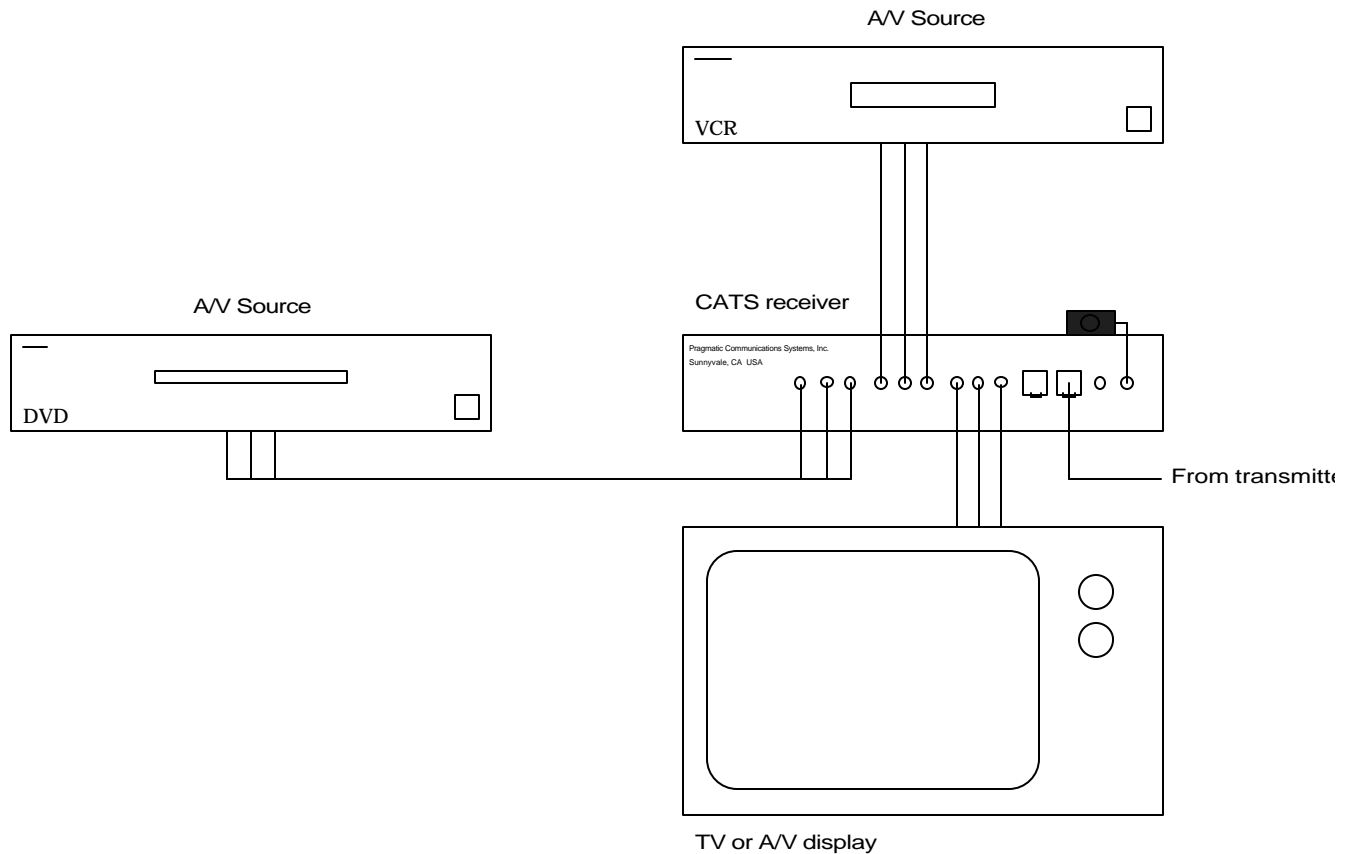

This example shows a CATS™ receiver with two local inputs. The receiver has three choices for what to display: from the transmitter, or from either of the two local inputs. This configuration has the advantage that all audio controls such as volume up/down/mute are handled by the receiver in a consistent manner.

Quick Installation

Important!

⇒ All connections should be made with the power turned **OFF!**

Note: The following pages detail each step of the installation process. Here is an overview of the installation process:

- 1.) Connect an IR emitter module to each transmitter unit.
- 2.) Connect an IR detector module to each receiver unit.
- 3.) Connect the A/V sources to each transmitter unit.
- 4.) Connect the A/V outputs from each receiver unit.
- 5.) Connect the CAT 5 cable to all units.
- 6.) Connect the power modules to all units.
- 7.) Setup the IR remote.
- 8.) System is now fully operational.

Transmitter Rear Panel

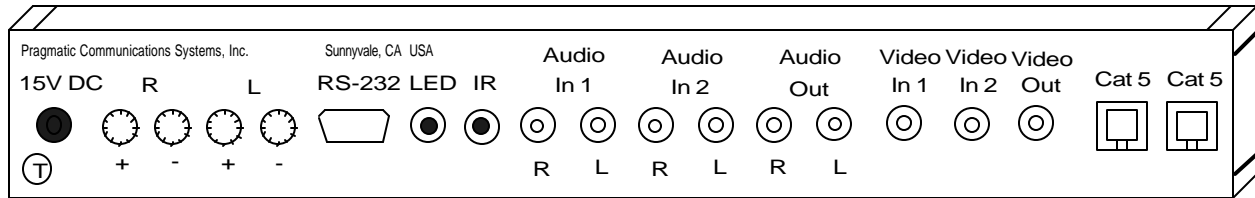

The transmitter is identified by the letter "T" on the rear panel. Each of the connectors on the transmitter are as follows:

Power Input: Accepts 15VDC input from supplied transformer.

R / L: In units equipped with a built-in power amp, these are the Right and Left outputs from the power amplifier.

RS-232: RS-232 connector

LED (IR Output): Stereo mini-jack connector provides the IR output signal to drive the IR emitter.

IR input: Stereo mini-jack accepts IR input from IR detector module.

Audio Inputs: These two inputs accept standard "line-level" stereo audio signals from the A/V source. Right and Left channels are as indicated.

Audio Output: This is the local audio output. Either input source can be selected.

Video Input: These two inputs accept a standard 1-volt p-p video input signal from the A/V source.

Video Output: This is the local video output.

CAT 5 connectors: These two connectors provide the output signal to drive the CAT 5 cable. Standard RJ-45 connectors are used. Two outputs are provided to make it easier to connect to multiple receivers. For cable pair usage, refer to the Application Note on page 26.

Receiver Rear Panel

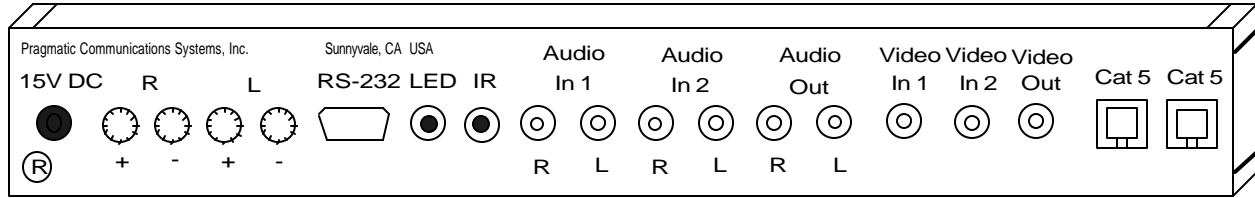

The receiver is identified by the letter "**R**" on the rear panel. Each of the connectors on the receiver are as follows:

Power Input: Accepts 15VDC input from supplied transformer.

R / L: In units equipped with a built-in power amp, these are the Right and Left outputs from the power amplifier.

RS-232: RS-232 connector

LED (IR Output): Stereo mini-jack connector provides the IR output signal to drive the IR emitter.

IR input: Stereo mini-jack accepts IR input from IR detector module.

Audio Inputs: These two inputs accept standard "line-level" stereo audio signals from the A/V source. Right and Left channels are as indicated.

Audio Output: This is the local audio output. Either input source can be selected.

Video Input: These two inputs accept a standard 1-volt p-p video input signal from the A/V source.

Video Output: This is the local video output.

CAT 5 connectors: These two connectors provide the output signal to drive the CAT 5 cable. Standard RJ-45 connectors are used. Two outputs are provided to make it easier to connect to multiple receivers. For cable pair usage, refer to the Application Note on page 26.

Router Rear Panel

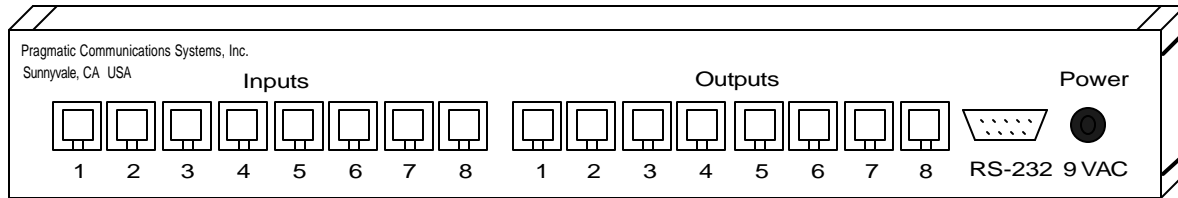

The CATS™ 8x8 router has a set of 8 RJ-45 connectors for the input signals, and a set of 8 RJ-45 connectors for the output signals. Each input accepts an encoded signal from the CATS™ transmitter unit. Each output provides an encoded output signal to drive up to 1000 feet of CAT 5 cable, and connect to the CATS™ receiver in each zone.

The RS-232 connector allows for external equipment to control the router. Refer to the Application Note on page 21 for the command set.

Power Input: Accepts the **9 VAC** power input from the supplied transformer. **Important:** make sure that the router is only connected to the proper **AC** supply, and not a DC supply for the transmitter or receiver.

IR detector / emitter Installation

Important!

Always have the power turned **OFF** prior to connecting or disconnecting the IR detector or emitter module.

Connect an IR emitter module to each transmitter unit. The IR emitter is connected by a stereo mini jack which is located to the right of the power connector on the rear panel.

The IR emitter should be located or attached so that it will operate the source equipment.

Connect the IR detector module that came with the system to each receiver unit and/or each transmitter unit as needed. The IR detector module is connected by a stereo mini jack which is located to the right of the power connector on the rear panel.

Important! Do not attempt to connect an IR detector module to an LED output, nor connect an IR emitter module to a IR detector input. Permanent damage to the equipment may occur.

The IR detector module should be located such that it has an unobstructed view of the room where the remote will be used. Best results are obtained if the IR detector is located away from interfering sources such as florescent lamps, or shielded from being directly illuminated by them.

Note: IR detectors from Xantech and others are **not** compatible with the CATS™ system. Do not attempt to connect an unapproved IR detector to the system, as permanent damage to the equipment may occur.

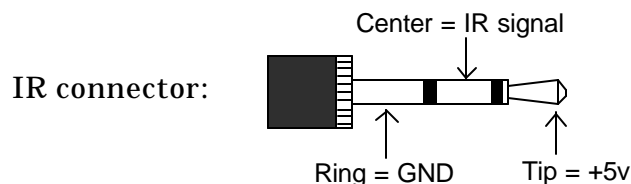

Audio / Video connections

The transmitter unit is configured to accept standard audio/video signals from a wide variety of sources, such as DVD players, Laser disk players, DSS receivers, CD players, VCRs, and other equipment.

The stereo audio inputs accept standard "line level" audio levels.

The video input accepts standard 1 volt p-p video levels.

Important! Do not connect any audio / video source that does not conform to standard "line level" signals!

Do not exceed $3 V_{\text{Rms}}$ into the "line level" audio inputs. Some high-end equipment may have higher signal levels. These should be attenuated or severe audio distortion may occur.

The receiver unit is configured to output standard "line level" audio levels at the stereo audio outputs, and standard 1 volt p-p video levels at the video output.

CAT 5 cable

Connection of the CAT 5 cable is very straightforward. The rear panels of each transmitter, receiver, and router contain sockets for the RJ-45 connectors. Simply plug in each RJ-45 connector into the appropriate socket to connect the units together into the desired topology.

Each transmitter contains two identical outputs so that it is capable of driving multiple receivers. The RJ-45 connector may be plugged into either output.

Each receiver contains two connectors to allow for multiple receivers to be easily daisy-chained together. Connect the primary CAT 5 cable from the transmitter into one socket. As needed, connect a daisy-chain cable from the other socket to the next receiver. Up to 16 receivers may be daisy-chained together in this way, provided that the total cable length is not too great, depending on the application, as each receiver added will cut down on the maximum length.

Although the system will work in a daisy-chain configuration, that is intended for industrial or other special applications where there needs to be multiple displays for the same source. For Home Theater applications, it is strongly recommended that for new designs and new construction, all the wires be home-run in a star configuration for maximum upgrade potential in the future.

The rear panel of the router has 8 input connections and 8 output connections. Connect each RJ-45 connector from each transmitter unit to the appropriate input connector of the router. Likewise, connect each RJ-45 connector from each receiver unit to the appropriate output connector of the router.

It doesn't matter what type of source is connected to each input of the router, but the chosen connections need to be clearly documented in a system application diagram so that the user will know what the actual connections are. Pragmatic has made the following suggestions as to how the input sources may be assigned:

Router Inputs:

- 1 = DSS
- 2 = DVD / LD
- 3 = VCR1
- 4 = VCR2 or other
- 5 = CD / Mini-Disc
- 6 = Tuner
- 7 = V. Aux
- 8 = DAT/Tape/DCC

Power connections

Each unit is supplied with a "wall-wart" style UL-approved transformer to supply the appropriate power for the unit. **Important!** Do not attempt to use any transformer other than a Pragmatic supplied or approved transformer. Use of any improper transformer may damage the unit.

The transmitter and receiver units are both designed to use a 15 VDC transformer with 500 mA or greater capacity. Plug the power connector of the supplied transformer into the power receptacle on the rear panel of the transmitter and receiver.

Receivers with a built-in Power Amplifier use a 13.8 VDC transformer at 1.7 A or greater capacity.

The router is designed to use a 9 VAC transformer (@ 1000 mA typical) for its supply. It is **extremely** important to use **only** the proper AC transformer for the router. Likewise, it is **extremely** important to make sure that the AC transformer for the router is **not** used for the transmitter or receiver, to prevent permanent damage to the units.

IR Remote Setup

This section only applies if the optional IR control system was purchased with the system. In this case, an "RCA SystemLink 3" universal remote and IR detector module for the receiver is included with the system.

The receiver responds to three different IR commands: Volume Up, Volume Down, and Mute. There is no setup required on the remote, because the volume control commands use the default settings (TV mode, code=000).

The router uses the same remote as the receiver for source input selection and control. The remote needs to be setup in "Cable" mode, code=034 . To do this, press and hold the "Code Search" button until the red LED stays lit. Then, press the "Cable" button to select the mode. Then enter in the code value, 034. After the third digit, the LED turns off and the remote returns to the operational mode. This will setup the remote to control the router.

Note: Selecting "Cable mode" on the remote to control the router does not affect the volume control commands for the receiver. The volume up/down/mute keys on the remote are not affected by the "Cable mode" selection which changes the operation of the numeric keys. Thus, the remote is fully able to control both the router and receiver, without even having to change the mode selection function.

If the user desires to control the router and receiver using a learning remote, such as the Marantz RC-2000 or similar, then follow that remote's instructions to transfer the control codes from the RCA remote to the learning remote.

Transmitter: The transmitter uses the same IR code setup as the receiver for all local control: volume/up/down/mute and local source select. If the transmitter has multiple source inputs, then the remote also needs to be setup in "Cable" mode, code=014. This code set only controls the transmitter from the destination location, through the receiver. The commands used are simply "1" or "2" to select the desired source input.

Operation: Local Inputs

Each transmitter and receiver is equipped with two local inputs. On the transmitter, either local input may be selected through to the local output. Selection is either with the IR remote, simply press "1" or "2", or by an RS-232 command. Independently of which input is selected for local output, either input may be selected for output through the CAT-5 cable. Selection is done either from the remote location with the IR remote, simply press "1" or "2" with the proper mode selected, or by an RS-232 command. The volume up/down/mute commands only affect the local outputs; the signals being sent through the CAT-5 cable are not affected by local commands.

The receiver has three choices for its A/V output: from the transmitter, or either of the two local inputs:

- 0 = from transmitter
- 1 = Local input 1 (Main)
- 2 = Local input 2 (Aux)

Selection is either with the IR remote, simply press "0", "1", or "2", or by an RS-232 command.

Operation: Router

The CATS™ 8x8 router is very easy to use: Press one of the numeric keys on the supplied remote (RCA Model RCU300T) to select the input for a given zone. For example, if a DVD player is connected to input 2 of the router, then press "2" on the remote to select the DVD player and send its output to the CATS™ receiver in that zone.

When using a Marantz RC-2000 or similar learning remote, the menu keys can be labelled for "DVD," "CD," and other devices, so that each device can be selected by simply pressing the appropriate menu key.

All-mode switching: The router also has the ability to switch all outputs (zones) to a given input with a single command. This is done by pressing the "Memo" (or Menu) key on the remote, then the number or device to select. For example, if the CD player is on input number 5, then press "Memo" - "CD" (or "Memo" - "5") to select the CD player for all zones. Note: Since the RCA remote lacks a "Menu" key, use the "Prev Ch" key to select this function.

There are two special cases for the All-mode switching. Press "Memo" - "0" to return the system to the previous settings. Press "Memo" - "9" to set the system for 1-to-1 connections; that is, connect output 1 to input 1, output 2 to input 2, and so on.

Router RS-232 Command Set

The router has an RS-232 port so that it may be controlled by an outside control system, either in addition to or in replacement of the IR control from the remote locations. These RS-232 commands only control the router; receiver units are controlled by IR commands as previously described.

RS-232 Interface

The RS-232 interface is set up for a direct connection from a COM port from the computer. The communications parameters are: 9600-8-N-1.

The commands are all simple single-letter ASCII commands. This allows the router to be controlled by either a "Dumb Terminal" program on the computer, or any other control program. The system can also be controlled by an entertainment system controller, such as AMX, Crestron, or other.

Command Set

R = Reset

The Reset command will reset the router to the power-up condition.

D = Display status

The Display status command displays the status of all output connections. For example:

```
Output: 12345678  
Input:  57286314
```

This display shows that output (or zone) #1 is being driven by input source #5, output #2 is being driven by input source #7, etc.

C = connect

The connect command allows for the selection of which input is to be connected to a given output. The first prompt is for the output, or zone number, and the second prompt is for the input source number. For example:

```
Connect
Output=7
Input=2
```

This command causes output #7 to be connected to input source #2. The display command is automatically executed after the connect command. Note: The above example shows the full prompts as seen when operating the router from a dumb terminal. When operating the router from a control program, the prompts can be ignored, and the connect command is executed by just sending the command and parameters. For example, to connect output #7 to input source #2 as above, the command is:

```
C72
```

"=" = non-verbose display status

The "=" command is similar to the Display status command, except that the header is omitted. Only the actual source connections are returned, as a list of eight numbers, in order by zone or output number. For example:

```
=57286314
```

This shows that output or zone #1 is being driven by input source #5, and that output #6 is being driven by input source #3, because input source #3 is listed sixth in the list.

The intention here is that the "D" command should be used by a person when operating the router from a "Dumb Terminal" program, while the "=" command is better suited for a computer program to retrieve the connection settings directly without having to wade through the extraneous header from the "D" command.

? = help

The "?" command will display a help screen of the above command list.

Receiver/Transmitter RS-232 Command Set

Command Summary:

D = Display status

V = Volume control

M = Mute control

S = Source selection

R = Remote Source selection

U = User configuration

General

These commands are designed to be used by either a "terminal emulation" program, or a control program which is capable of issuing these commands.

All commands are single letters. Some commands need parameters, as noted.

Command Descriptions:

D = Display status

The Display command is used to display the status of the device.

V = Volume control

v+ = volume up

v- = volume down

v## = volume set

The volume control command needs one of three parameters, as shown. The v+ command increases the volume until the maximum limit. The v- command decreases the volume until the lower limit. The v## command sets the volume to the specified value. The value must be two digits (in hex) and must be between 1B hex (minimum

volume) and 3F hex (maximum volume.) The value of 3C hex sets the volume for line-out mode.

M = Mute control

m+ = Mute ON

m- = Mute OFF

The m+ command sets the mute ON (no audio.) The m- command sets the mute OFF (normal, audio on.)

S = Source selection

s# where # is a single digit defined below.

This command is used for the local source input selection. For the receiver, there are three choices:

0 = (from Tx)

1 = Main

2 = Aux

For the transmitter, there are two choices:

1 = Main

2 = Aux

R = Remote Source selection

r# where # is a single digit defined below.

Note: This command is only applicable to the transmitter.

This command selects which of the two inputs are sent to the receiver. The selected input sent to the receiver is totally independent from the selected input for the local output.

1 = Main

2 = Aux

This command is the same as the remote source selection command available

through the IR remote.

U = User configuration

Note: This command is only applicable to the transmitter.

This command allows the user to enter in the source labels used by the receiver to display the type of source selected. For example, if the Main input has been set to "DSS" and the Aux input set to "VCR", then the receiver can display which input has been selected by name.

The prompts are very easy to follow. First, the system will display the current settings for reference. Then, the following prompt will appear:

Enter 1 for Main, 2 for Aux, or Esc to exit:

Enter in the desired choice for which selection to change. Then, enter in the new value for the source label at the prompt. Each source label may be up to 16 characters.

Ethernet Color code for CAT-5

1. WHT/OR
2. OR
3. WHT/GRN
4. BLU
5. WHT/BLU
6. GRN
7. WHT/BRN
8. BRN

Twisted

Pairs	Pragmatic CATS assignment
4-5	IR data
3-6	Audio and Video signals
1-2	Reserved.
7-8	Reserved.

Note: It is **VERY** important that the Audio and Video signals be connected properly to a **PAIR** of wires in order to maintain signal integrity.

In other words, if the cable connections are such that the Audio and Video signals are using two wires taken from **DIFFERENT** pairs, then the system will not function properly. It is not good enough just to have DC continuity for the signal path; the signal path **MUST** be over a proper twisted-pair in order for the system to function.

Troubleshooting Hints

Symptom: No audio or video at outputs.

Possible causes:

- 1.) It has been our experience that almost all problems encountered are due to improper connections at either the input signals, the output signals, or the CAT-5 wiring. Therefore, the first step is always to review all of the connections, and make sure that all input/output connections are correct, as well as making sure that all of the equipment has the proper power applied, and make sure that the blue power LEDs on the front are illuminated. For the CAT-5 wiring, refer to the preceding section, and ensure that all color codes and crimping connections are correct.
- 2.) For systems that include a router, make sure that the router has the proper input selected. If possible, connect a computer to the RS-232 port, and verify that the input/output settings are as intended. Use an RJ-45 female-to-female coupler to bypass the router and verify that all of the cable connections are correct.

Symptom: Audio works, but no video.

Possible causes:

- 1.) Because the audio and video signals use separate input and output connections, the most likely cause is that one of these connections is not correct, on either the transmitter (check video input) or receiver end (check video output).
- 2.) Verify that the cable length has not exceeded the 1000 foot limit. Since the audio signals will travel farther than the video signals, the video signal will be lost first if the cable length is excessive.
- 3.) In rare cases, problems with the CAT-5 wiring may allow the audio signals to pass, but not the video signals. Refer to the preceding section, and verify that the CAT-5 wiring is correct.

Symptom: Video works, but no audio.

Possible causes:

- 1.) As above, the most likely cause is that one of the audio connections at either the transmitter or receiver end is not correct.
- 2.) The volume setting in the receiver may be set too low. Use the supplied remote to increase the volume level to an appropriate setting.

3.) Make sure that the router has the proper input selected.

Symptom: IR control doesn't work.

Possible causes:

- 1.) Check the batteries in the remote. Check to make sure the remote is set to the proper mode and that the proper device code has been set.
- 2.) Make sure that the detector module has been installed properly, and that it is not being overwhelmed by florescent lights.

Symptom: IR controls the receiver, but not the router.

Possible causes:

- 1.) Because the router uses a different device setting than the receiver, make sure that the proper device code has been set into the remote for "Cable" mode, and that the "Cable" mode has been selected.
- 2.) Since the IR commands are sent on a different pair of wires than the audio and video signals, problems with the CAT-5 wiring could prevent the IR signals from working even though the audio and video work fine. Therefore, verify that all CAT-5 wiring and connections are correct for the IR signals.