

# MiniMax<sup>®</sup> CH

## POOL & SPA HEATERS

### OPERATION & INSTALLATION MANUAL

#### ⚠ WARNING

#### FOR YOUR SAFETY - READ BEFORE OPERATING

**Warning:** If you do not follow these instructions exactly, a fire or explosion may result, causing property damage, personal injury or loss of life. For additional free copies of this manual; call (800) 831-7133.



To  
Consumer  
Retain For  
Future  
Reference

U.S. Patent Numbers  
6,295,980  
5,318,007 - 5,228,618  
5,201,307 - 4,595,825

#### ⚠ WARNING

**Warning:** Improper installation, adjustment, alteration, service or maintenance can cause property damage, personal injury or death. Installation and service must be performed by a qualified installer, service agency or the gas supplier.

#### For Your Safety

#### WHAT TO DO IF YOU SMELL GAS

- Do not try to light any appliance.
- Do not touch any electrical switch; do not use any phone in your building.
- Immediately call your gas supplier from a neighbor's phone. Follow the gas supplier's instructions.
- If you cannot reach your gas supplier, call the fire department.

Do not store or use gasoline or other flammable vapors and liquids in the vicinity of this or other appliances.

#### Pentair Pool Products, Inc.

1620 Hawkins Ave., Sanford, NC 27330 • (919) 774-4151  
10951 W. Los Angeles Ave., Moorpark, CA 93021 • (805) 523-2400

# Table of Contents

<b>Introduction</b> .....	<b>3</b>
Important Notices .....	3
Warranty Information .....	4
<b>Operation</b> .....	<b>4</b>
Safety Rules .....	4
Millivolt Lighting/Operation - Natural & Propane .....	5
Operating (Controls) .....	6
<b>Maintenance</b> .....	<b>7</b>
Maintenance Instructions .....	7
Relief Valve .....	7
Energy Saving Tips .....	7
Spring and Fall Operation .....	7
Winter Operation .....	7
Chemical Balance .....	8
<b>Installation Instructions</b> .....	<b>9</b>
<b>Specifications</b> .....	<b>9</b>
<b>Plumbing Connections</b> .....	<b>10</b>
Plumbing/Valves .....	10
Manual Bypass .....	10
Below Pool Installation .....	10
<b>Water Connections</b> .....	<b>11</b>
Reverse Water Connections .....	11
Insulating High Limits when Reversing Heads .....	11
<b>Gas Connections</b> .....	<b>12</b>
Gas Line Installation .....	12
Pipe Sizing Chart/Gas Pressure Requirements .....	12
Pipe Sizing Chart/Propane 2 Stage Regulation .....	13
Regulated Manifold Pressure Test .....	13
<b>Ventilation</b> .....	<b>14</b>
Outdoor Installation Requirements .....	14
Outdoor Cap Installation .....	14
Indoor Installation Requirements .....	15
Installation on Floors Constructed of Combustible Materials .....	16
Indoor Draft Hood Installation .....	16
<b>Electrical</b> .....	<b>17</b>
Millivolt Wiring Diagram .....	17
<b>Trouble Shooting (General)</b> .....	<b>18</b>
<b>MiniMax CH Parts List &amp; Exploded View</b> .....	<b>19-21</b>
<b>MiniMax CH (150 IID Model) Appendix</b> .....	<b>A1-A9</b>
<b>MiniMax CH (150 IID Model) Parts List &amp; Exploded View</b> .....	<b>A10-A12</b>
<b>Warranty Information</b> .....	<b>Back Cover</b>

# Introduction

## MiniMax CH Pool and Spa Heaters

Congratulations on your purchase of a MiniMax CH high performance heating system. Proper installation and service of your new heating system and correct chemical maintenance of the water will ensure years of enjoyment. The MiniMax CH is a compact, lightweight and efficient gas fired high performance pool and spa heater that can be directly connected to schedule 40 PVC pipe and has a built-in top. The MiniMax CH is a millivolt heater and has a self sustaining pilot and requires NO external power source.

### IMPORTANT NOTICES

...For the installer and operator of the MiniMax CH pool and spa heater. The manufacturer's warranty may be void if, for any reason, the heater is improperly installed and/or operated. Be sure to follow the instructions set forth in this manual. If you need any more information, or if you have any questions regarding to this pool heater, please contact Pentair Pool Products, Inc. at (800) 831-7133.

These heaters are designed for the heating of swimming pools and spas, and should never be employed for use as space heating boilers, general purpose water heaters, in non-stationary installations, or for the heating of salt water.

### **⚠ CAUTION**

**OPERATING THIS HEATER CONTINUOUSLY AT WATER TEMPERATURE BELOW 68° F. WILL CAUSE HARMFUL CONDENSATION AND WILL DAMAGE THE HEATER AND WILL VOID THE WARRANTY.**

Do not use the heater to protect pools or spas from freezing if the final maintenance temperature desired is below 68° F. as this will cause condensation related problems.

### **CODE REQUIREMENTS**

The installation must conform with local codes or in the absence of local codes with the latest National Fuel Gas Code, ANSI Z223.1, and the latest edition of the National Electrical Code, NFPA 70.

Installation in Canada to be made in accordance with the latest CAN/CGA-B149.1 or .2 and CSA C22.1 Canadian Electric Code, part 1.



This instruction manual provides operating instructions, installation and service information for the MiniMax CH high performance heater. The information in this manual applies to the MiniMax CH 150, 200, 250, 300, 350, and 400 natural gas and propane (LP) models.

It is very important that the owner/installer read and understand the section covering installation instructions, and recognize the local and state codes before installing the MiniMax CH. History and experience has shown that most heater damage is caused by improper installation practices.

## WARRANTY INFORMATION

The MiniMax CH pool heater is sold with a limited factory warranty. *Specific details are described on the back cover of this manual and a copy of the warranty and warranty registration card are included with the product.* Return the warranty registration card after filling in the serial number from the rating plate inside the heater.

*Pentair Pool Products' high standards of excellence include a policy of continuous product improvement resulting in your state-of-the-art heater. We reserve the right to make improvements which change the specifications of the heater without incurring an obligation to update the current heater equipment.*

## Operation



### SAFETY RULES

1. Spa or hot tub water temperatures should never exceed 104° F (40° C). A temperature of 100° F (38° C) is considered safe for a healthy adult. Special caution is suggested for young children.
2. Drinking of alcoholic beverages before or during spa or hot tub use can cause drowsiness which could lead to unconsciousness and subsequently result in drowning.
3. Pregnant women beware! Soaking in water above 102° F (39° C) can cause fetal damage during the first three months of pregnancy (resulting in the birth of a brain-damaged or deformed child). Pregnant women should stick to the 100° F (38° C) maximum rule.
4. Before entering the spa or hot tub, the user should check the water temperature with an accurate thermometer. Spa or hot tub thermostats may err in regulating water temperatures by as much as 4° F (2.2° C).
5. Persons with a medical history of heart disease, circulatory problems, diabetes or blood pressure problems should obtain their physician's advice before using spas or hot tubs.
6. Persons taking medication which induce drowsiness, such as tranquilizers, antihistamines or anticoagulants should not use spas or hot tubs.

### ⚠ WARNING

**Should overheating occur or the gas supply fail to shut off, turn off the manual gas control valve to the appliance. Do not use this heater if any part has been under water. Immediately call a qualified service technician to inspect the heater and to replace any part of control system and gas control which has been under water.**

# MINIMAX CH MILLIVOLT LIGHTING/OPERATION-NATURAL GAS & PROPANE

## FOR YOUR SAFETY: READ BEFORE LIGHTING

### ⚠ WARNING



If you do not follow these instructions exactly, a fire or explosion may result causing personal injury, loss of life and property damage.

Since propane gas is heavier than air, escaping propane will accumulate and remain at ground level. Do not attempt to light the heater. If you suspect a propane leak, lighting the heater can result in a fire or explosion which can cause personal injury, death, and property damage.

- A. This heater is equipped with a pilot which must be lighted manually. When lighting the pilot, follow these instructions exactly.
- B. **BEFORE LIGHTING** smell all around the heater area for gas. Be sure to smell next to the floor because some gas is heavier than air and will settle on the floor.
- Do not try to light any heater.
- Do not touch any electrical switch; do not use any phone in your building.
- Immediately call your gas supplier from a neighbor's phone. Follow the gas supplier's instructions.
- If you cannot reach your gas supplier, call the Fire Department.
- C. Use only your hand to push in or turn the gas control knob. Never use tools. If the knob will not push in or turn by hand, don't try to repair it. Call a qualified service technician. Forced or attempted repair may result in a fire or explosion.
- D. Do not use this heater if any part has been under water. Immediately call a qualified service technician to inspect the heater and to replace any part of the control system and any gas control which has been under water.

### WHAT TO DO IF YOU SMELL GAS

## LIGHTING INSTRUCTIONS

1. **STOP!** Read the safety information above.
2. Set the thermostat to the lowest setting.
3. Turn off electric power to the heater.
4. Push in gas control knob slightly and turn clockwise to "OFF".
7. Push the control knob all the way and hold in. Immediately light the pilot with Presslite matchless ignition system by pressing the red igniter button (located at the panel next to the gas valve). Continue to hold the control knob in for about one (1) minute after the pilot is lit. Release knob and it will pop back up. Pilot should remain lit. If it goes out, repeat steps 4 through 7.

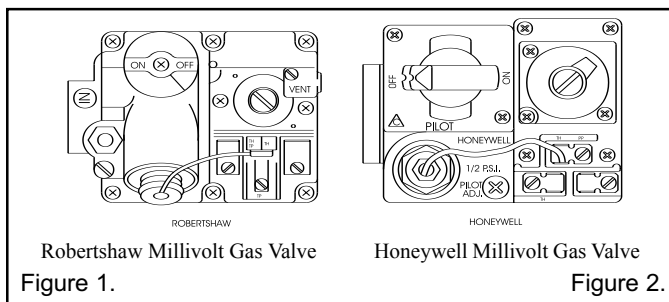

Gas control knobs shown in "OFF" position.

### NOTE

Knob cannot be turned from "Pilot to "OFF"" unless knob is pushed in slightly. **DO NOT FORCE.**

5. Wait five (5) minutes to clear out any gas. If you then smell gas, **STOP!** Follow "B" in the safety information above. If you don't smell gas, go to the next step.
6. Push in gas control knob slightly and turn counterclockwise to "Pilot".

- If knob does not pop up when released, stop and immediately call your service technician or gas supplier.

Figure 3.

- If the pilot will not stay lit after several tries, turn the gas control knob to "OFF" and call your service technician or gas supplier.

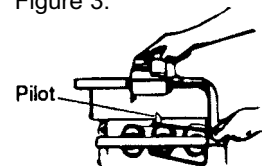

8. Turn knob on gas control counterclockwise to "ON".
9. Replace the control access door.
10. Set the thermostat to the desired setting.

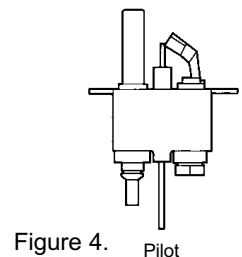

Figure 4.

## TO TURN OFF GAS TO HEATER

1. Set the thermostat to lowest setting.
2. Turn off all electric power to the heater if service is to be performed.
3. Remove control access door.
4. Push in gas control knob slightly and turn clockwise to "OFF". **Do not force.**
5. Replace control access door.

## **OPERATING (CONTROLS)**

### **Dual Temperature Control System**

For convenience and economy all MiniMax CH heaters are equipped with two thermostats on the front of the heater control panel; see Figure 5.

#### **THERMOSTAT KNOB STOPPER**

Each thermostat is equipped with a mechanical stop that can be locked or unlocked with use of a screwdriver to prevent temperatures in excess of that desired by the user; see Figure 6.

The maximum setting can be adjusted by loosening the screw "A" and turning the stopper dial to desired maximum setting. Lock the setting by tightening the screw. The Mechanical stop is under the knob. Ensure that the knob is stopping at the correct position when the knob is rotated clockwise from a lower temperature position. (See Thermostat Adjustment.)

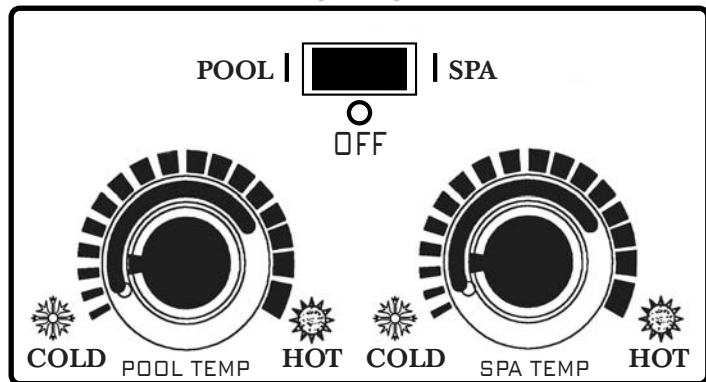

Figure 5.

#### **NOTE**

**To eliminate error due to piping heat losses, measure pool temperature with an accurate thermometer directly at the pool or spa.**

#### **THERMOSTAT ADJUSTMENT**

The knob with locking feature eliminates the need for constant thermostat adjustments. Set the knob pointer to the desired pool or spa temperature.

If further adjustment is needed, rotate the knob until the desired temperature is obtained. This knob position corresponding to your desired maximum pool or spa temperature may now be preset (locked) by the knob stopper which prevents the knob from being turned beyond the maximum temperature you set.

#### **POWER (THERMOSTAT SELECT) SWITCH**

The Pool/Off/Spa switch allows the heater to be turned off when heating is not desired.

1. "Pool" position - Maintains selected pool temperature.
2. "Off" position - Heater will not come on regardless of drop in pool or spa temperature.
3. "Spa" position - This allows separate control of spa water temperature or an alternate lower pool temperature.

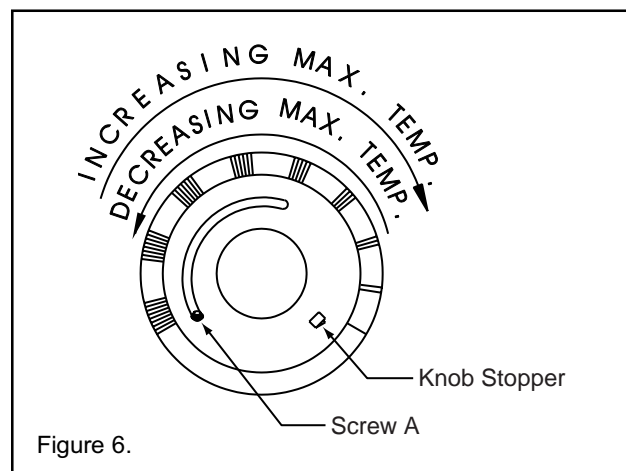

Figure 6.

# Maintenance

## MAINTENANCE INSTRUCTIONS

It is recommended that you check the following items at least every six months and at the beginning of every swimming season.

1. Examine the venting system. Make sure there are no obstructions in the flow of combustion and ventilation air.
2. Visually inspect the main burner and the pilot burner flame. The normal color of the flame is blue. When flame appears yellow, burners should be inspected and cleaned; see Figure 8.
3. Keep the heater area clear and free from combustibles and flammable liquids.

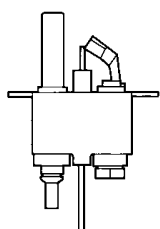

Figure 7.

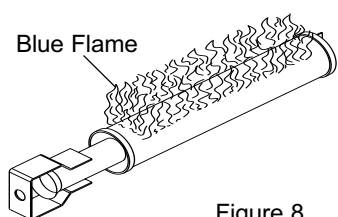

Figure 8.

## CAUTION

**REMOVE THE FLOW VALVE ASSEMBLY WHEN DRILLING THE HOLE TO INSTALL A PRV. OTHERWISE, YOU WILL DRILL INTO THE VALVE ASSEMBLY.**

### Pressure Relief Valve

In some installations, a pressure relief valve (PRV) is required on the MiniMax CH heater. To install a PRV, carefully drill a 3/8 in. hole in center of 3/4 in. NPT port (on main header) being careful to drill only thru wall at bottom of 3/4 in. NPT port and no deeper—now thread in the 3/4 NPT PRV. (Sold separately.)

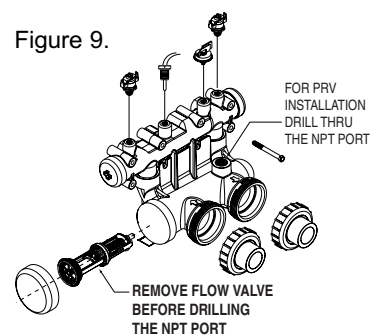

Figure 9.

## ENERGY SAVING TIPS

1. If possible, keep pool or spa covered when not in use. This will not only cut heating costs, but also keep dirt and debris from settling in the pool and conserve chemicals.
2. Reduce the pool thermostat setting to 78° F. or lower. This is accepted as being the most healthy temperature for swimming by the American Red Cross.
3. Use an accurate thermometer.
4. When the proper maximum thermostat settings have been determined, tighten the thermostat knob stopper.
5. Set time clock to start circulation system no earlier than daybreak. The swimming pool loses less heat at this time.
6. For pools that are only used on the weekends, it is not necessary to leave the thermostat set at 78° F. Lower the temperature to a range that can be achieved easily in one day. Generally, this would be 10° F. to 15° F., if pool heater is sized properly.
7. During the winter or while on vacation, turn the heater off.
8. Set up a regular program of preventative maintenance for the heater each new swimming season. Check heat exchanger, controls, burners, operation, etc.

## SPRING AND FALL OPERATION

If the pool is being used occasionally, do not turn the heater completely off. Set the thermostat down to 65° F. This will keep the pool and the surrounding ground warm enough to bring the pool up to a comfortable swimming temperature in a shorter period of time.

## WINTER OPERATION

## CAUTION

**OPERATING THIS HEATER CONTINUOUSLY AT WATER TEMPERATURE BELOW 68° F. WILL CAUSE HARMFUL CONDENSATION AND WILL DAMAGE THE HEATER AND WILL VOID THE WARRANTY.**

If the pool won't be used for a month or more, turn the heater off at the main gas valve. For areas where there is no danger of water freezing, water should circulate through the heater all year long, even though you are not heating your swimming pool. The MiniMax CH should not be operated out doors at temperatures below 0° F. for propane and -20° F. for natural gas. Where freezing is possible, it is necessary to drain the water from the heater. This may be done by opening the drain valve located at the inlet/outlet header (see Figure 9.) allowing all water to drain out of the heater. It would be a good practice to use compressed air to blow the water out of the heat exchanger. (See additional notes under Important Notices in Introduction on page 3.)

## CHEMICAL BALANCE

### POOL AND SPA WATER

Your Pentair Pool Products pool heater was designed specifically for your spa or pool and will give you many years of trouble free service provided you keep your water chemistry in proper condition.

Three major items that can cause problems with your pool heater are improper pH, disinfectant residual, and total alkalinity. These items, if not kept properly balanced, can shorten the life of the heater and cause permanent damage.

### CAUTION

Heat exchanger damage resulting from chemical imbalance is not covered by the warranty.

### WHAT A DISINFECTANT DOES

Two pool guests you do not want are algae and bacteria. To get rid of them and make pool water sanitary for swimming - as well as to improve the water's taste, odor and clarity - some sort of disinfectant must be used.

Chlorine and bromine are universally approved by health authorities and are accepted disinfecting agents for bacteria control.

### WHAT IS A DISINFECTANT RESIDUAL?

When you add chlorine or bromine to the pool water, a portion of the disinfectant will be consumed in the process of destroying bacteria, algae and other oxidizable materials. The disinfectant remaining is called chlorine residual or bromine residual. You can determine the disinfectant residual of your pool water with a reliable test kit, available from your local pool supply store.

You must maintain a disinfectant residual level adequate enough to assure a continuous kill of bacteria or virus introduced into pool water by swimmers, through the air, from dust, rain or other sources.

It is wise to test pool water regularly. Never allow chlorine residual to drop below 0.6 ppm (parts per million). The minimum level for effective chlorine or bromine residual is 1.4 ppm.

**pH** - The term pH refers to the acid/alkaline balance of water expressed on a numerical scale from 0 to 14. A test kit for measuring pH balance of your pool water is available from your local pool supply store; see Table 1.

Table 1. pH Chart

Strongly Acid			Neutral				Strongly Alkaline							
0	1	2	3	4	5	6	7	8	9	10	11	12	13	14

Muriatic Acid has a pH of about 0. Pure water is 7 (neutral). Weak Lye solution have a pH of 13-14.

**RULE:** 7.4 to 7.6 is a desirable pH range. It is essential to maintain correct pH, see Table 2.

### If pH becomes too high (over alkaline), it has these effects:

1. Greatly lowers the ability of chlorine to destroy bacteria and algae.
2. Water becomes cloudy.
3. There is more danger of scale formation on the plaster or in the heat exchanger.
4. Filter elements may become blocked.

### If pH is too low (over acid) the following conditions may occur:

1. Excessive eye burn or skin irritation.
2. Etching of the plaster.
3. Corrosion of metal fixtures in the filtration and recirculation system, which may create brown, blue, green, or sometimes almost black stains on the plaster.
4. Corrosion of copper in the heater, which may cause leaks.
5. If you have a sand and gravel filter, the alum used as a filter aid may dissolve and pass through the filter.

**CAUTION:** Do not test for pH when the chlorine residual is 3.0 ppm or higher, or bromine residual is 6.0 ppm or higher. See your local pool supply store for help in properly balancing your water chemistry.

**RULE:** Chemicals that are acid lower pH. Chemicals that are alkaline raise pH.

Table 2. pH Control Chart

6.8	7.0	7.2	7.4	7.6	7.8	8.0	8.2	8.4
Add Soda, Ash or Sodium Bicarbonate		Marginal	Ideal	Marginal	Add Acid			

### ALKALINITY High - Low:

"Total alkalinity" is a measurement of the total amount of alkaline chemicals in the water, and control pH to a great degree. (It is not the same as pH which refers merely to the relative alkalinity/acidity balance.) Your pool water's total alkalinity should be 100 - 140 ppm to permit easier pH control.

A total alkalinity test is simple to perform with a reliable test kit. You will need to test about once a week and make proper adjustments until alkalinity is in the proper range. Then, test only once every month or so to be sure it is being maintained. See your local pool dealer for help in properly balancing the water chemistry.



# Installation Instructions

## SPECIFICATIONS

**IMPORTANT NOTICE:** These installation instructions are designed for use by qualified personnel only, trained especially for installation of this type of heating equipment and related components. Some states require installation and repair by licensed personnel. If this applies in your state, be sure your contractor bears the appropriate license.

### Outdoor installation - stackless

Model	"A" Dim	"B" Dim
150	17 7/8 in.	6 1/2 in.
200	20 7/8 in.	9 1/2 in.
250	23 7/8 in.	12 1/2 in.
300	26 7/8 in.	15 1/2 in.
350	29 7/8 in.	18 1/2 in.
400	33 3/8 in.	22 3/8 in.

Table 3.

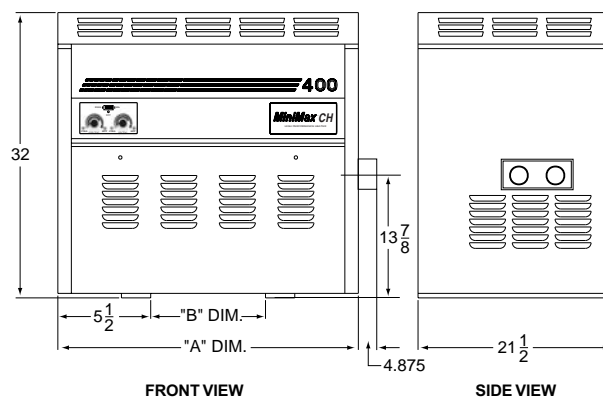

### Outdoor installation - with vent kit

Model	"A" Dim	"B" Dim	"C" Dim	"D" Dim
150	17 7/8 in.	6 1/2 in.	7 3/4 in.	39 3/4 in.
200	20 7/8 in.	9 1/2 in.	10 in.	42 3/4 in.
250	23 7/8 in.	12 1/2 in.	10 in.	42 3/4 in.
300	26 7/8 in.	15 1/2 in.	10 1/4 in.	43 3/4 in.
350	29 7/8 in.	18 1/2 in.	13 in.	47 3/4 in.
400	33 3/8 in.	22 3/8 in.	17 in.	51 3/4 in.

Table 4.

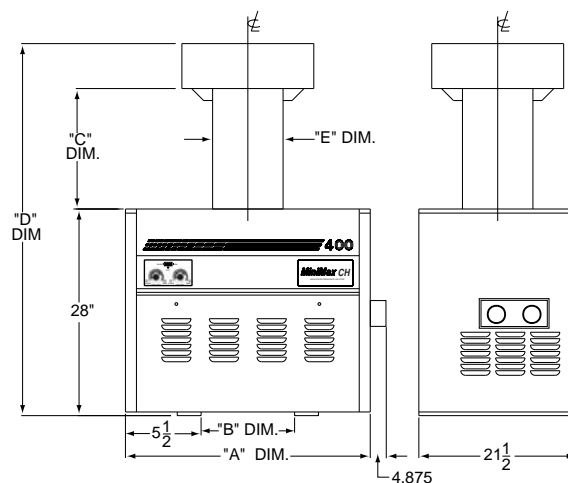

### Indoor installation - stack (USA only)

### Outdoor shelter installation (Canada)

Model	"A" Dim	"B" Dim	"C" Dim	"D" Dim	"E" Dim
150	17 7/8 in.	6 1/2 in.	13 in.	52 1/4 in.	6 in.
200	20 7/8 in.	9 1/2 in.	13 in.	53 7/8 in.	7 in.
250	23 7/8 in.	12 1/2 in.	13 in.	53 7/8 in.	7 in.
300	26 7/8 in.	15 1/2 in.	13 in.	55 in.	8 in.
350	29 7/8 in.	18 1/2 in.	13 in.	56 in.	9 in.
400	33 3/8 in.	22 3/8 in.	17 in.	60 3/4 in.	10 in.

Table 5.

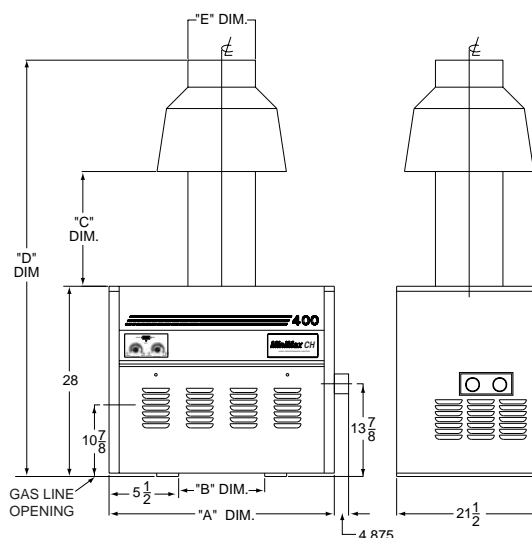

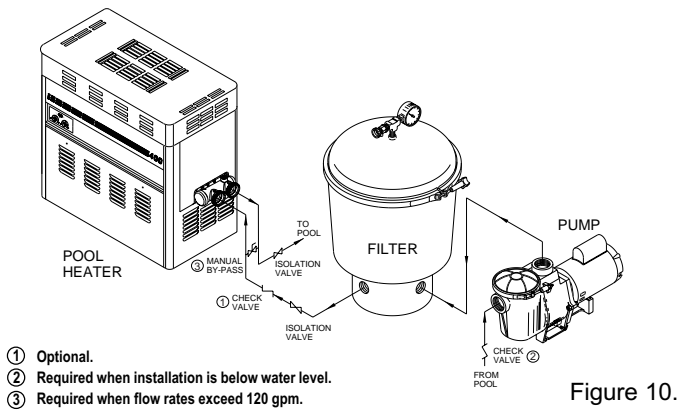

### MANUAL BY-PASS

Where the flow rate exceeds the maximum 120 GPM, a manual bypass should be installed and adjusted. After adjustments are made, the valve handle should be removed to avoid tampering.

Model	Min.	Max. *
150	20	120
200	20	120
250	30	120
300	30	120
350	40	120
400	40	120

\* Do not exceed the maximum recommended flow rate for the connecting piping.

Table 6.

## PLUMBING CONNECTIONS

The MiniMax CH heater has the unique capability of direct schedule 40 PVC plumbing connections.

<b>⚠ CAUTION</b>
<p>Before operating the heater on a new installation, turn on the circulation pump and bleed all the air from the filter using the air relief valve on top of the filter. Water should flow freely through the heater.</p>

Do not operate the heater unless water in the pool/spa is at the proper level.

## PLUMBING

### VALVES

When any equipment is located below the surface of the pool or spa, valves should be placed in the circulation piping system to isolate the equipment from the pool or spa.

Check valves are recommended to prevent back siphon.

<b>⚠ CAUTION</b>
<p>Exercise care when installing chemical feeders so as to not allow back siphoning of chemical into the heater, filters or pump. When chemical feeders are installed in the circulation of the piping system, make sure the feeder outlet line is down stream of the heater, and is equipped with a positive seal non-corrosive "Check Valve", (P/N R172288), between the feeder and heater.</p>

### BELOW POOL INSTALLATION

If the heater is below water level, the pressure switch should be adjusted. This adjustment must be done by a qualified service technician. See following CAUTION.

<b>⚠ CAUTION</b>
<b>BELOW OR ABOVE POOL INSTALLATION</b>
<p>The water pressure switch is set in the factory at 1½ PSI. This setting is for a heater installed at pool level or within 3' above or 3' below. If the heater is to be installed more that 3' above or 3' below, the water pressure switch must be adjusted by a qualified service technician.</p>
<b>FLOW SWITCH</b>
<p>If the heater is installed more the 6' above the pool or more than 10' below the pool level, you will be beyond the limits of the pressure switch and a flow switch must be installed. Locate and install the flow switch externally on the outlet piping from the heater, as close as possible to the heater. Connect the flow switch wires in place of the water pressure switch wires.</p>

## WATER CONNECTIONS

### Reversible Inlet/Outlet Connection

The MiniMax CH heater is factory assembled with right side inlet/outlet water connections. The inlet/outlet header can be reversed for left side water connections without removing the heat exchanger.

Reversing Water Connections

Disassembly

Tools needed:

- 1/4 in Nut Driver
- 9/16 in. Socket and Wrench
- 1/2 in. & 9/16 in. Open Wrench
- Screw Driver(s) - (Flathead & Phillips)

1. Remove the inspection plates.
2. Disconnect all wires from the high-limit switches except the short jumper wire. The exact order of the disconnection is not important.

### NOTE

There is no reason to **remove** the high-limit and pressure switches or the thermister from the front header during the reversing procedure, as they will be in the proper location when installed on the left side.

3. Disconnect the pressure switch wiring.
4. Disconnect the thermostat thermister leads from the control board.
5. Exchange the in/out header with the return header. Replace the heat exchanger tube seals with new seals provided in the Quick-Flange Accessory Bag.
6. Install the temperature sensing bulb by passing the wires through the hole provided on the left side of the brace panel. Route wires through the support bracket.
7. Reconnect all the high limit wires. Reconnect the pressure switch wiring. Route the wires through the same hole as the thermostat sensor wires and reconnect thermister to the board.
8. Reinstall the inspection plates.

## INSULATING THE HIGH LIMITS

### When Reversing Heads on the MiniMax CH Heater

On the MiniMax CH heater there is insulation installed by the factory on the return head side of the heaters. This insulation is there so that if the heads are reversed in the field, during initial installation of the heater, the reflected heat from the flue collector will be insulated from the high limits.

**Return head in position before removal.**  
**This view shows the insulation installed by the factory.**

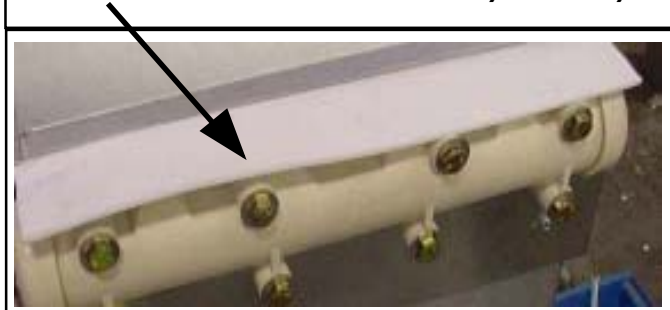

**Return head removed and new tube seals installed. Now ready to accept the installation of the main head.**

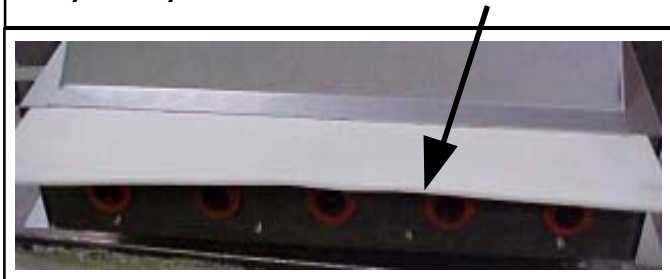

**Lift the installation to allow the main head to be installed.**  
**When head is placed into position, release the insulation; it will now shield the high limits from the heat produced by the flue collector.**

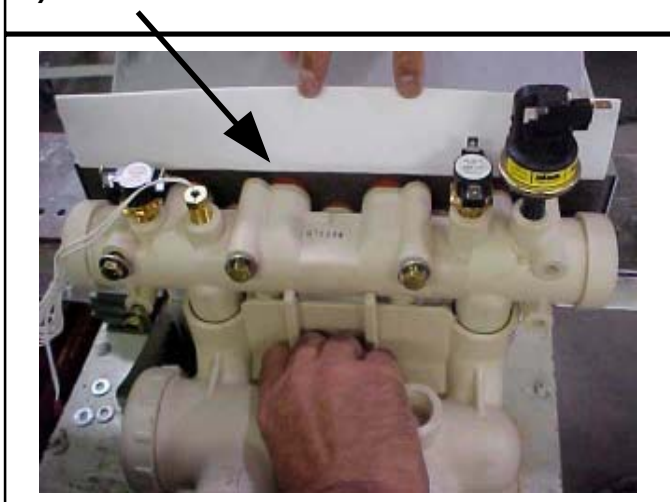

## **GAS CONNECTIONS**

### **GAS LINE INSTALLATIONS**

Before installing the gas line, be sure to check which gas the heater has been designed to burn. This is important because different types of gas require different gas pipe sizes. The rating plate on the heater will indicate which gas the heater is designed to burn. Tables 7-9, on pages 12 and 13, shows which size pipe is required for the distance from the gas meter to the heater. The table is for natural gas at a specific gravity of .65 and propane at specific gravity of 1.5.

When sizing gas lines, calculate three (3) additional feet of straight pipe for every elbow used.

When installing the gas line, avoid getting dirt, grease or other foreign material in the pipe as this may cause damage to the gas valve, which may result in heater failure.

*The gas meter should be checked to make sure that it will supply enough gas to the heater and any other appliances that may be used on the same meter.*

*The gas line from the meter will usually be of a larger size than the gas valve supplied with the heater. Therefore a reduction of the connecting gas pipe will be necessary. Make this reduction as close to the heater as possible.*

The heater and any other gas appliances must be disconnected from the gas supply piping system during any pressure testing on that system, (greater than ½ PSIG).

The heater and its gas connection must be leak tested before placing the heater in operation. **Do not use flame to test the gas line.** Use soapy water or another nonflammable method.

**A manual main shut-off valve must be installed externally to the heater.**

### **⚠ WARNING**

**Do not install the gas line union inside the heater cabinet. This will void your warranty.**

#### **Pipe Sized For Length Of Run In Equivalent Feet**

Table 7.

<b>PIPE SIZING FOR GAS LINE CONNECTIONS</b>														
<b>MAXIMUM EQUIVALENT PIPE LENGTH</b>														
Natural gas at 1000 B.T.U. per Cubic Foot														
Propane Gas at 2500 B.T.U. per Cubic Foot														
<b>MODEL</b>	<b>1/2"</b>		<b>3/4"</b>		<b>1"</b>		<b>1-1/4"</b>		<b>1-1/2"</b>		<b>2"</b>		<b>2-1/2"</b>	
	NAT	PRO	NAT	PRO	NAT	PRO	NAT	PRO	NAT	PRO	NAT	PRO	NAT	PRO
75 & 100	20'	50'	50'	150'	150'	600'	-	-	-	-	-	-	-	-
150	10'	40'	50'	150'	150'	600'	-	-	-	-	-	-	-	-
200	-	20'	30'	80'	125'	250'	450'	600'	-	-	-	-	-	-
250	-	10'	20'	50'	70'	150'	250'	500'	600'	-	-	-	-	-
300	-	-	10'	30'	50'	100'	200'	350'	400'	600'	-	-	-	-
350	-	-	10'	20'	30'	70'	125'	250'	250'	500'	500'	-	-	-
400	-	-	-	10'	20'	60'	100'	150'	200'	450'	400'	-	-	-
525	-	-	-	5'	15'	35'	65'	150'	130'	360'	390'	700'	-	-
750	-	-	-	-	-	20'	35'	80'	75'	180'	260'	600'	-	-
900	-	-	-	-	-	15'	20'	50'	45'	80'	150'	360'	400'	-

**Pipe Sized For Length Of Run In Equivalent Feet, (cont'd.)**

**PROPANE 2 STAGE REGULATION**

In many "RESIDENTIAL" Propane gas line installations, the gas supplier and or installer will utilize a two stage regulation process where by at the supply tank they will install the first stage gas regulator, which would be at a higher pressure, usually 10 psi and can be for longer distance and in a smaller pipe size. Then within a short distance from the heater they will install a second regulator, which is the second stage, and this would be set at the required inlet pressure of 11 inches of W.C. for all the Pentair Pool Heaters.

Stage One "High Pressure" Gas Pipe Sizing			
MAXIMUM EQUIVALENT PIPE LENGTH			
Model	0 to 50 Feet	50 to 100 Feet	100 to 150 Feet
75 & 100	1/2 in.	1/2 in.	1/2 in.
150	1/2 in.	1/2 in.	1/2 in.
200	1/2 in.	1/2 in.	1/2 in.
250	1/2 in.	1/2 in.	1/2 in.
300	1/2 in.	1/2 in.	1/2 in.
350	1/2 in.	1/2 in.	1/2 in.
400	1/2 in.	1/2 in.	1/2 in.

Table 8.

Stage Two "Low Pressure" Gas Pipe Sizing		
MAXIMUM EQUIVALENT PIPE LENGTH		
Model	0 to 10 Feet	10 to 20 Feet
75 & 100	1/2 in.	1/2 in.
150	1/2 in.	1/2 in.
200	1/2 in.	3/4 in.
250	1/2 in.	3/4 in.
300	3/4 in.	3/4 in.
350	3/4 in.	3/4 in.
400	3/4 in.	3/4 in.

Table 9.

**REGULATED MANIFOLD PRESSURE TEST**

1. Attach the manometer to the heater jacket.
2. Shut off the main gas valve.
3. Remove 1/8 in. NPT plug on the outlet side of the valve and screw in the fitting from the manometer kit.
4. Connect the manometer hose to the fitting.
5. Fire the heater.
6. The manometer must read 4 in. WC for natural gas, 11 in. WC for propane gas, **while** the heater is operating.
7. For adjustment, remove the Regulator Adjustment Cap and using a screwdriver turn the screw clockwise to increase - counterclockwise to decrease gas pressure.

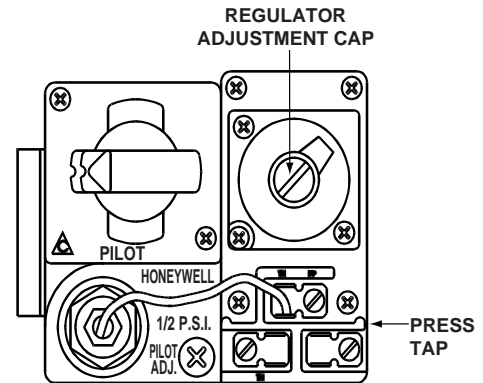

Figure 11.

**MINIMAX CH GAS PRESSURE REQUIREMENTS\***

	Natural	Propane
Maximum inlet gas pressure	10 in. WC	14 in. WC
Minimum inlet gas pressure	**5 in. WC	12 in. WC
Normal manifold pressure	4 in. WC	11 in. WC
** 6 WC for 400 model		

\*All Readings are taken with the heater fired. Any adjustments made with heater off will give incorrect readings.

Table 10.

**CAUTION**

The use of Flexible Connectors (FLEX) is NOT recommended as they cause high gas pressure drops.

## VENTILATION

### OUTDOOR INSTALLATION ONLY

For outdoor installation with built in vent top, the heater must be placed in a suitable area on a level, noncombustible surface. Do not install the heater under an overhang with clearances less than 3 feet from the top of the heater. The area under an overhang must be open on three sides.

#### IMPORTANT!

**In an outdoor installation it is important to protect your heater from water damage. Ensure water is diverted from overhanging eaves with a proper gutter/drainage system. The heater must be set on a level foundation for proper rain drainage.**

Maintain minimum clearances as indicated below. Install a minimum of 4 feet below, and 4 feet horizontally from any opening to a building.

The heater should not be installed closer than 6 inches to any fences, walls or shrubs at any side or back, or any combustible material, nor closer than 18 inches at the plumbing side. A minimum clearance of 24 inches must be maintained at the front of the heater.

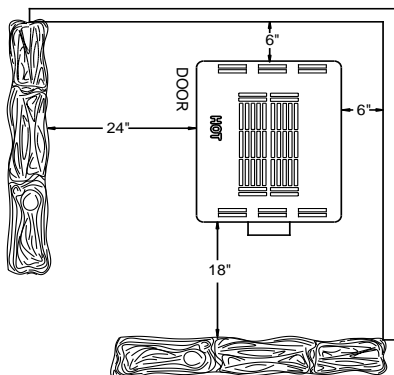

Figure 12.

#### IMPORTANT!

**When locating the heater, consider that high winds can roll over or deflect off adjacent buildings and walls. Normally, placing the heater at least three feet from any wall will minimize downdraft.**

*Unusually high prevailing wind conditions and downdrafts may require the use of a stack type outdoor vent kit (available at additional cost).*

#### NOTE

This unit shall not be operated outdoors at temperatures below 0° F. for propane and -20° F. for natural gas.

### STACK TYPE OUTDOOR VENT KIT

Model	Vent Cap	Product No.	Vent Dia.
150	OV15	460237	6 in.
200	OV20	460222	7 in.
250	OV25	460223	7 in.
300	OV30	460224	8 in.
350	OV35	460225	9 in.
400	OV40	460226	10 in.

Table 11.

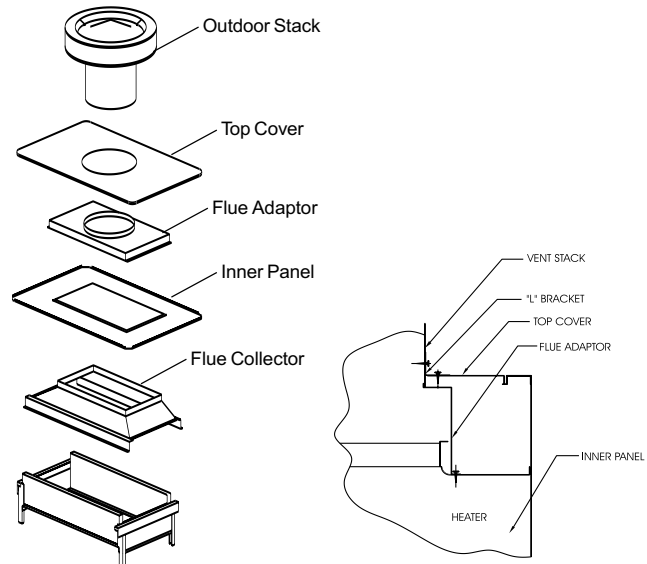

Figure 13.

Figure 14.

### OUTDOOR VENT CAP INSTALLATION

The MiniMax CH heater is shipped standard as an outdoor stackless unit. To install the outdoor vent kit:

1. Take out the louvered outer top after first removing all 1/4 in. sheet metal screws attaching it along its perimeter to the cabinet. Set it aside.
2. Place the flue adaptor over the flue collector opening. Temporarily, put the top cover, from the kit, on with the label to the front of the heater. Center the flue adaptor evenly inside the top cover flue stack opening. Remove the top cover and secure the centered flue adaptor to the inner panel with the provided #8 x 1/2 in. drill qwik screws.
3. Place the top cover, with the hole for the stack, on the heater cabinet.
4. Install the vent stack through the hole in the top cover, over the flue adaptor top ring.
5. Using a 3/32 in. drill bit, position the "L" bracket to hold the top cover and outdoor stack. Drill the pilot holes through the "L" bracket holes to accept the screws.
6. Secure the vent stack and the inner top with the #8 x 1/4 in. sheet metal screws through the "L" brackets.

**INDOOR INSTALLATION (USA ONLY)  
OUTDOOR SHELTER INSTALLATION  
(CANADA)**

All products of combustion and vent gases must be completely removed to the outside atmosphere through a vent pipe which is connected to the draft hood. A vent pipe extension of the same size must be connected to the draft hood and extended at least 2 feet higher than highest point of the roof within a 10 foot horizontal radius, and at least 3 ft. higher than the point at which it passes through the roof, or as permitted by local code; see Figures 15 and 16. The vent should terminate with an approved vent cap (weather cap) for protection against rain or blockage by snow. Double-wall vent pipe and an approved roof jack shall be employed through the roof penetration. The use of double-walled type B vent pipe is recommended.

The draft hood must be installed so as to be in the same atmospheric pressure zone as the combustion air inlet to the pool heater. The certified (factory) draft hood **must not** be modified in any way and must be employed in every indoor installation.

The heater must be located as close as practical to a chimney or gas vent. The heater should be installed at least 5 feet away from the pool or spa.

The heater must be placed in a suitable room on a non-combustible floor or on a non-combustible base and in an area where leakage from heat exchanger or water connections will not result in damage to the area adjacent to the heater or the structure. When such locations cannot be avoided, it is recommended that a suitable drain pan with adequate drainage, be installed under the heater. The pan must not restrict air flow.

Installations in basements, garages, or underground structures where flammable liquids may be stored must have the heater elevated 18 inches from the floor using a non-combustible base. *The following minimum clearances from combustible materials must be provided.*

	Side	Front	Back	Top
Water Connection	18 in.	24 in.		
Remaining	6 in.		6 in.	
Ceiling Clearance				36 in.*

\*To ceiling or roof.

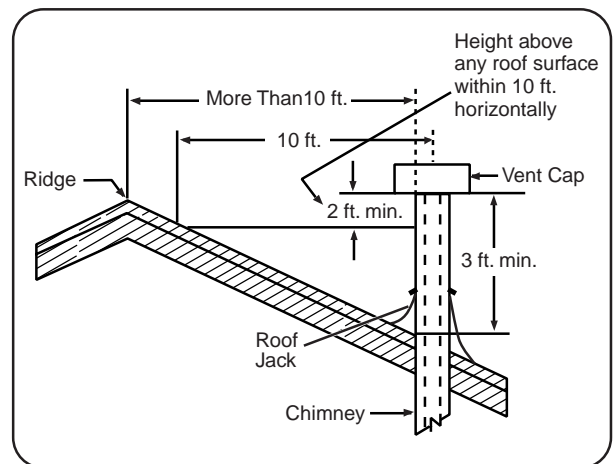

Figure 15.

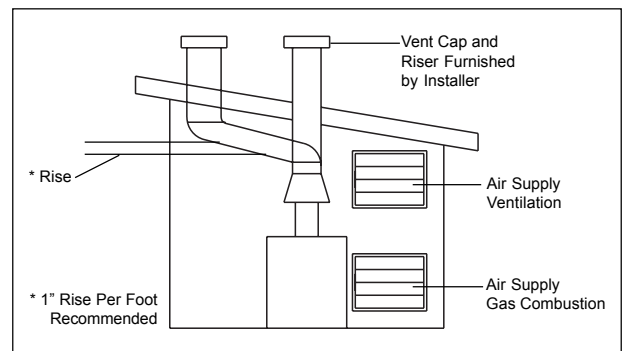

Figure 16.

**NOTE**

The heater requires **two uninterrupted air supply openings**; one for ventilation and one to supply oxygen for proper gas combustion. The air supply openings should be sized according to Tables 12. and 13.

*Air supply requirements below apply to all MiniMax heaters*

**All opening sizes are minimum and unobstructed.**

All Air From Inside		
Model	Air for Combustion Sq. In.	Air Ventilation Sq. In.
150	150	150
200	200	200
250	250	250
300	300	300
350	350	350
400	400	400

Table 12.

All Air From Outside		
Model	Air for Combustion Sq. In.	Air Ventilation Sq. In.
150	37	37
200	50	50
250	63	63
300	77	77
350	90	90
400	100	100

Table 13.

**INSTALLATION ON FLOORS CONSTRUCTED OF COMBUSTIBLE MATERIALS**

The heater may be placed on a “combustible floor” using either of the two methods listed below:

- a) Use Listed Factory Non-combustible Base Kit for use on combustible floors.

Model	Non-Combustible Base Kit
150	471389
200	471390
250	471391
300	471392
350	471393
400	471394

Table 14.

- b) Construct a non-combustible base from masonry blocks as illustrated, see Figure 17.

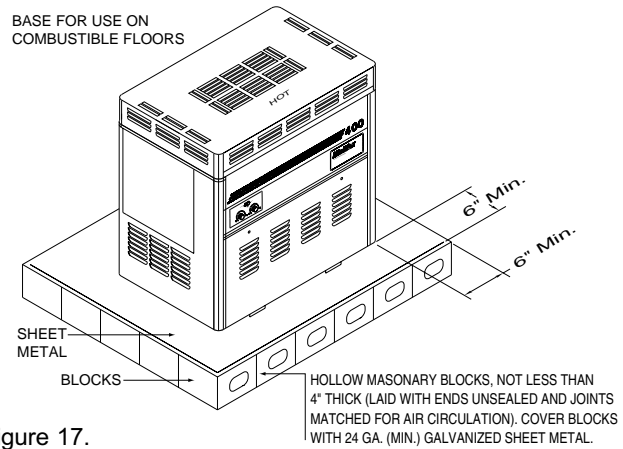

Figure 17.

**CAUTION**

Chemicals should not be stored near the heater installation. Combustion air can be contaminated by corrosive chemical fumes which can void the warranty.

**STACK TYPE INDOOR DRAFT HOOD KIT**

The proper draft hood and adapter must be installed on the heater as shown below:

Model	Draft Hood	Product No.	Vent Dia.
150	DH15	460227	6 in.
200	DH20	460228	7 in.
250	DH25	460230	7 in.
300	DH30	460231	8 in.
350	DH35	460233	9 in.
400	DH40	460234	10 in.

Table 15.

**INDOOR DRAFT HOOD INSTALLATION**

1. Take out the louvered outer top piece after first removing the sheet metal screws, attaching it to the cabinet.
2. Install the adaptor (vent kit).
3. Install the top cover (vent kit).
4. Install the draft hood (vent kit).

Use the provided screws to secure the vent assembly.

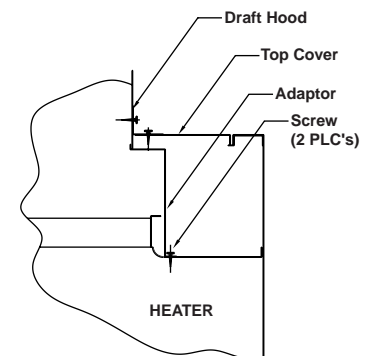

Figure 18.



# ELECTRICAL

## MiniMax CH Millivolt Wiring Diagram

### MINIMAX WIRING DIAGRAM (MILLIVOLT) DUAL THERM (HONEYWELL ELECTRONIC)

IF ORIGINAL FACTORY WIRING MUST BE REPLACED, INSTALLER MUST SUPPLY UL OR CSA (IF CANADA) APPROVED WIRE, 18 GAUGE, 600V, 105 C° TEMPERATURE RATING. THERMAL FUSE WIRING MUST BE REPLACED WITH UL OR CSA (IF CANADA) APPROVED WIRE, 18 GAUGE, 600V, 125 C° TEMPERATURE RATING. INTERCONNECTING WIRING TO APPLIANCE MUST CONFORM TO THE NATIONAL ELECTRICAL CODE OR SUPERCEDING LOCAL (WIRING) CODES.

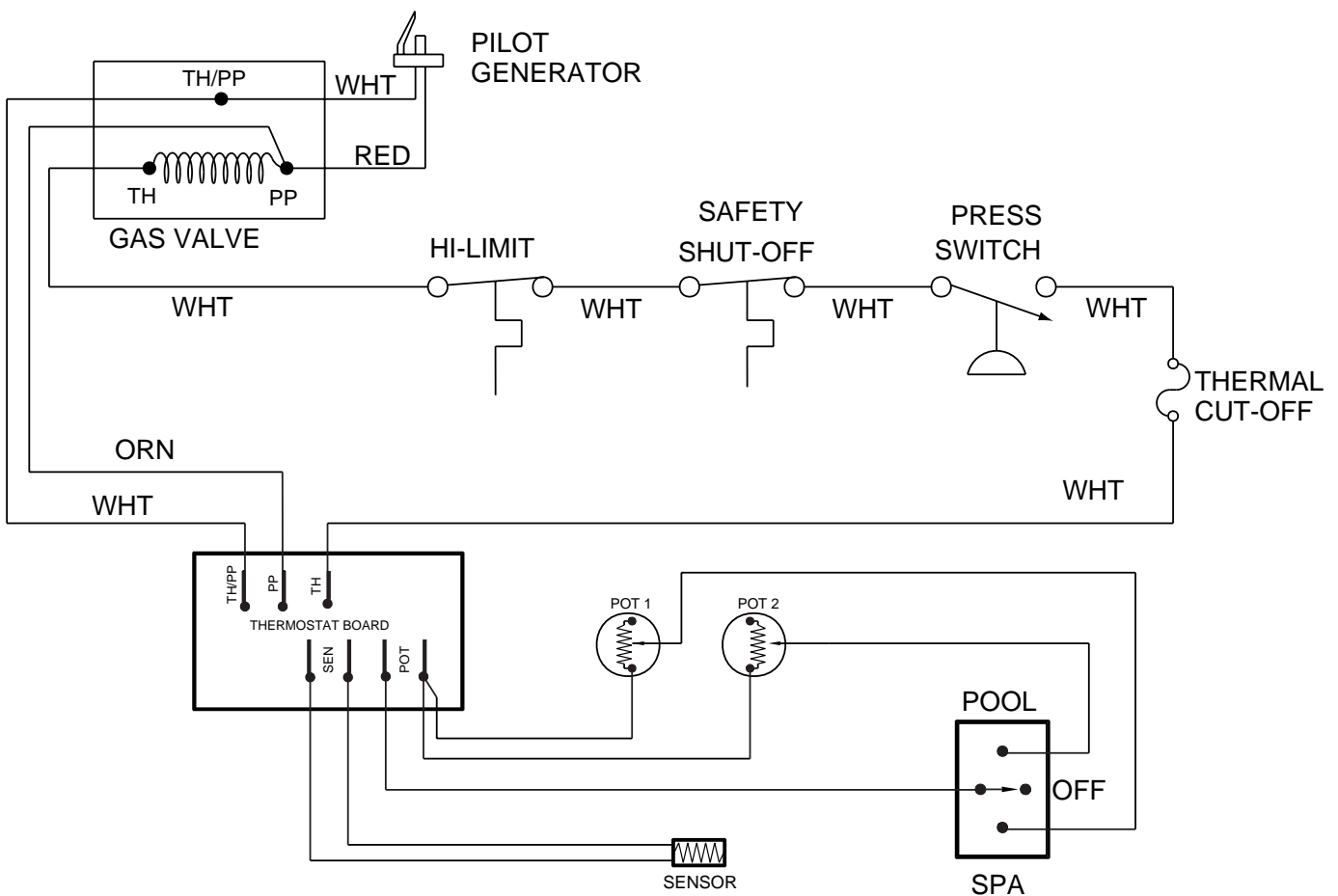

Figure 19.

**NOTE:** When connecting a remote control to the MiniMax CH, you must install the low voltage thermostat wires in separate conduit from **ANY** line voltage wires. Failure to follow these instructions will cause the thermostat relay to react erratically.

## Troubleshooting - General

<i>Possible Cause</i>	<i>Remedy</i>
<b>Heater will not come on</b>	
Pump not running	Place pump in operation
Pump air locked	Check for leaks
Filter dirty	Clean filter
Pump strainer clogged	Clean strainer
Defective wiring or connection	Repair or replace wires
Defective pressure switch	Replace switch
Defective gas controls	Call serviceperson
On-Off switch in "OFF" position	Turn switch to "ON"
<b>Heater Short Cycling (Rapid On and Off Operation)</b>	
Insufficient water flow	Clean filter and pump strainer
Defective wiring	Repair or replace wiring
Defective flow valve or out of adjustment	Call serviceperson
Defective hi-limit and/or thermostat	Call serviceperson
<b>Heater Makes Knocking Noises, Make sure all valves on system are open</b>	
Heater operating after pump has shut off	Shut off gas supply and call serviceperson
Heater exchanger scaled	Shut off gas supply and call serviceperson

### CAUTION

Please consult the latest edition of the "MiniMax Service Manual" for complete service and repair instructions. Repairs should only be attempted by properly trained service personnel.

# MINIMAX CH HEATER - ALL MODELS

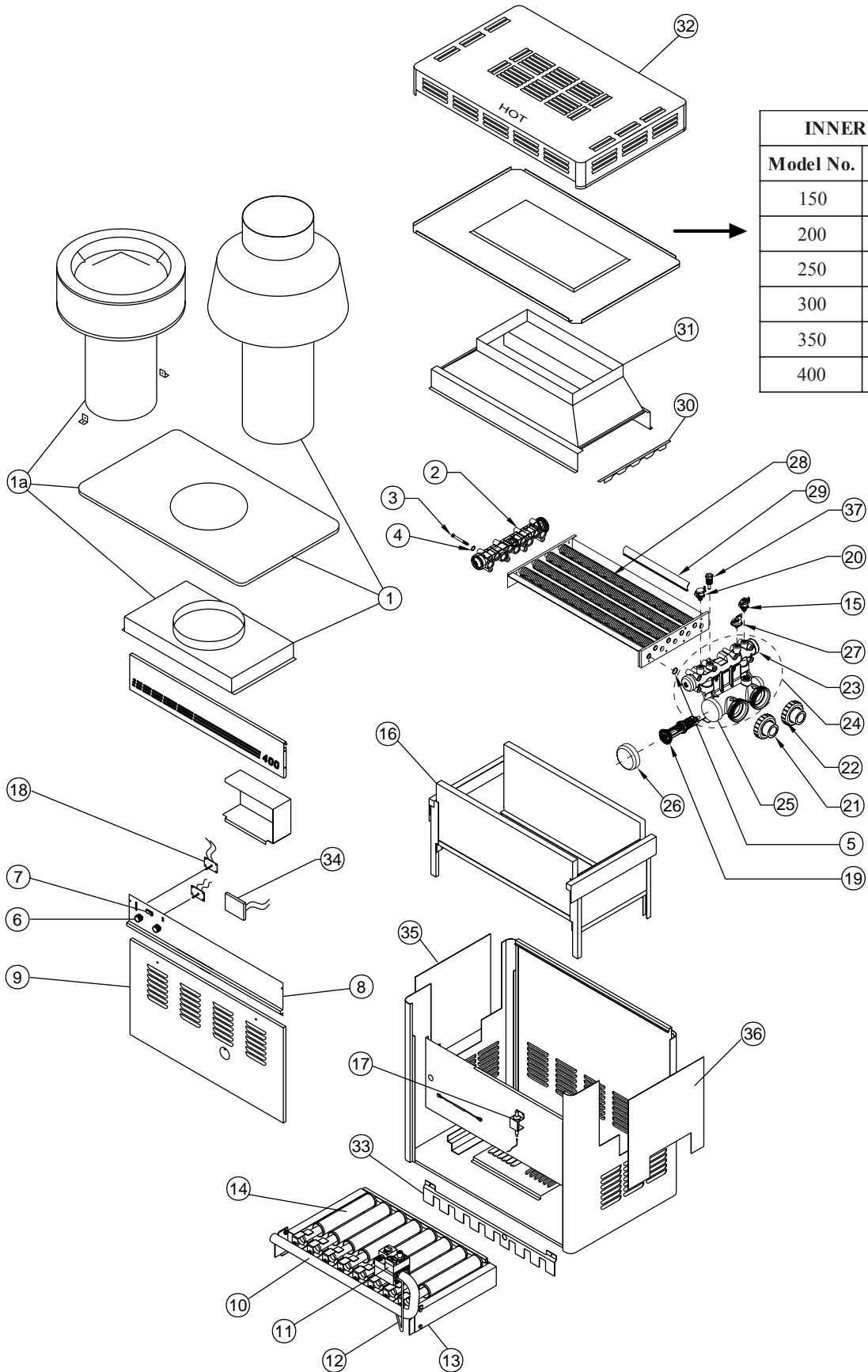

INNER TOPS	
Model No.	Part No.
150	470024
200	470025
250	470026
300	470027
350	470028
400	470029

## MiniMax CH Parts List

ITEM	DESCRIPTION	QTY	150	200	250	300	350	400
1	Vent kit assy. (indoor)	1	460227	460228	460230	460231	460233	460234
1a	Vent kit assy. (outdoor)	1	460237	460222	460223	460224	460225	460226
2	Return header	1	070994	070994	070994	070994	070994	070994
3	Bolt, heat exchanger	16	471991	471991	471991	471991	471991	471991
4	Washer 3/8" ID 1" OD	16	072184	072184	072184	072184	072184	072184
5	Tube seal gasket	18	070951	070951	070951	070951	070951	070951
6	Thermostat knob	2	470184	470184	470184	470184	470184	470184
7	Switch rocker (single pole & double throw)	1	470186	470186	470186	470186	470186	470186
8	Control panel assy. (complete) - Millivolt	1	472175	472174	472173	472172	472171	472170
9	Door - Millivolt	1	075468	075604	075488	075605	075606	075490
10	Manifold burner	1	070256	075525	070257	075526	075527	070258
11	Gas valve natural - Millivolt	1	075457	075457	075457	075457	075457	075457
	Gas valve propane - Millivolt	1	075458	075458	075458	075458	075458	075458
12	Pilot tube - Millivolt		076084	076084	076085	076085	076086	076086
13	Burner tray assy. natural (complete) - Millivolt	1	075493	075496	075494	075497	075498	075495
	Burner tray assy. propane (complete) - Millivolt	1	075502	075505	075503	075506	075507	075504
14	Burner		2 EA. 070230	3 EA. 070230	4 EA. 070230	5 EA. 070230	6 EA. 070230	7 EA. 070230
14a	Burner with pilot bracket (not shown)	1	470550	470550	470550	470550	470550	470550
15	Pressure switch	1	471672	471672	471672	471672	471672	471672
16	Combustion chamber assy. (complete)	1	073858	075586	073857	075587	075588	073856
17	Presslite igniter assy.	1	075459	075459	075459	075459	075459	075459
18	Potentiometer	2	471678	471678	471678	471678	471678	471678
19	Flow valve assy.	1	471750	471750	471750	471750	471750	471750
20	Hi-Limit thermostat 115°	1	471587	471587	471587	471587	471587	471587
21	Adaptor - bulkhead, 2 in.	2	471441	471441	471441	471441	471441	471441
22	Adaptor - bulkhead ring	2	274440	274440	274440	274440	274440	274440
23	Main manifold assy.	1	471993	471993	471993	471993	471993	471993
24	Main header assy.	1	471992	471992	471992	471992	471992	471992
25	Main manifold bottom	1	471419	471419	471419	471419	471419	471419
26	Cap, main manifold bottom	1	471420	471420	471420	471420	471420	471420
27	Hi-Limit thermostat 150°	1	471694	471694	471694	471694	471694	471694
28	Heat exchanger (without heads)	1	472131	472132	472133	472134	472135	472136
	Heat exchanger (with heads)	1	472169	472168	472167	472166	472165	472164
29	Baffle		8 ea. 070277	8 ea. 075559	8 ea. 070276	8 ea. 075560	16 ea. 070277	16 ea. 070278
30	Baffle hold down (2) baffles on 400	1	073810	073810	073810	073810	073810	073810

### MiniMax CH Parts List, *contd.*

ITEM	DESCRIPTION	QTY	150	200	250	300	350	400
31	Flue collector	1	073864	075622	073863	075623	075624	073862
32	Outdoor top assy.	1	470471	470472	470473	470474	470475	470476
33	Lightback shield (Propane Gas units only)	1	075783	075784	075785	075786	075787	075788
34	Electronic thermostat (Millivolt models)	1	471677	471677	471677	471677	471677	471677
35	Panel (return)	1	073789	073789	073789	073789	073789	073789
36	Panel (in/out)	1	472127	472127	472127	472127	472127	472127
37	Thermistor (probe) complete (Millivolt models)	1	472101	472101	472101	472101	472101	472101
<b>* Not Shown</b>								
*	Plastic mounting bracket		070715	070715	070715	070715	070715	070715
*	Clips for wire harness		471277	471277	471277	471277	471277	471277
*	Wire Kit - Millivolt		075511	075511	075511	075511	075511	075511
*	Screw 8 x 1/4" HH		071703	071703	071703	071703	071703	071703
*	Screw 8 x 1/2" HH		071698	071698	071698	071698	071698	071698
*	Screw 6 x 1/4"		071716	071716	071716	071716	071716	071716
*	Screw 10 -32 x 1/4"		071659	071659	071659	071659	071659	071659
*	Screw 10-32 x 3/16		075692	075692	075692	075692	075692	075692
*	Bushing 1/2"		070551	070551	070551	070551	070551	070551
*	Therm knob stopper	2	470414	470414	470414	470414	470414	470414
*	Bolt 5/16" - 18 x 3/4'	2	073725	073725	073725	073725	073725	073725
			3 ea. N or P	4 ea. N or P	5 ea. N or P	6 ea. N or P	7 ea. N or P	8 ea. N or P
*	Orifice main burner natural		073727	073727	073727	073727	073727	073727
*	Orifice main burner propane		073728	073728	073728	073728	073728	073728
*	Pilot - natural - Millivolt	1	471292	471292	471292	471292	471292	471292
*	Pilot - propane - Millivolt	1	471291	471291	471291	471291	471291	471291
*	Pilot - generator	1	071515	071515	071515	071515	071515	071515
*	Thermal cutoff - fusible link	1	075173	075173	075173	075173	075173	075173
*	Power element (flow-valve)	1	470178	470178	470178	470178	470178	470178
*	Pilot rainshield	1	471293	471293	471293	471293	471293	471293
*	Pilot electrode (only)	1	471328	471328	471328	471328	471328	471328
*	"L" brackets	3	074540	074540	074540	074540	074540	074540
*	Bracket adapter Q379 pilot, MV		471271	471271	471271	471271	471271	471271
*	Jumper		072253	072253	072253	072253	072253	072253
*	Door latch		071240	071240	071240	071240	071240	071240



# MiniMax® CH (150 IID Model)

## POOL & SPA HEATERS OPERATION & INSTALLATION MANUAL (APPENDIX)

### ⚠ WARNING

#### FOR YOUR SAFETY - READ BEFORE OPERATING

**Warning:** If you do not follow these instructions exactly, a fire or explosion may result, causing property damage, personal injury or loss of life. For additional free copies of this manual; call (800) 831-7133.



U.S. Patent Numbers  
6,295,980  
5,318,007 - 5,228,618  
5,201,307 - 4,595,825

### ⚠ WARNING

**Warning:** Improper installation, adjustment, alteration, service or maintenance can cause property damage, personal injury or death. Installation and service must be performed by a qualified installer, service agency or the gas supplier.

#### For Your Safety

#### WHAT TO DO IF YOU SMELL GAS

- Do not try to light any appliance.
- Do not touch any electrical switch; do not use any phone in your building.
- Immediately call your gas supplier from a neighbor's phone. Follow the gas supplier's instructions.
- If you cannot reach your gas supplier, call the fire department.

Do not store or use gasoline or other flammable vapors and liquids in the vicinity of this or other appliances.

#### Pentair Pool Products, Inc.

1620 Hawkins Ave., Sanford, NC 27330 • (919) 774-4151  
10951 W. Los Angeles Ave., Moorpark, CA 93021 • (805) 523-2400

**MINIMAX CH (150 IID) ELECTRONIC IGNITION LIGHTING/OPERATION - NATURAL GAS**

**FOR YOUR SAFETY: READ BEFORE LIGHTING**

**⚠ WARNING**





If you do not follow these instructions exactly, a fire or explosion may result causing personal injury, loss of life and property damage.

Do not attempt to light the heater if you suspect a natural gas leak. Lighting the heater can result in a fire or explosion which can cause personal injury, death, and property damage.

- A. This heater is equipped with an ignition device which automatically lights the pilot. Do not try to light the pilot by hand.
  - B. **BEFORE OPERATING** smell all around the heater area for gas. Be sure to smell next to the floor because some gas is heavier than air and will settle on the floor.
  - C. Use only your hand to push in or turn the gas control knob. Never use tools. If the knob will not push in or turn by hand, don't try to repair it. Call a qualified service technician. Forced or attempted repair may result in a fire or explosion.
  - D. Do not use this heater if any part has been under water. Immediately call a qualified service technician to inspect the heater and to replace any part of the control system and any gas control which has been under water.
  - E. The MiniMax CH incorporates (9) nine indicator lights to aid you in the operation of the heater, and to assist in diagnosing a failure in the heater's function.
- WHAT TO DO IF YOU SMELL GAS**
- Do not try to light any heater.
  - Do not touch any electrical switch; do not use any phone in your building.
  - Immediately call your gas supplier from a neighbor's phone. Follow the gas supplier's instructions.
  - If you cannot reach your gas supplier, call the Fire Department.

**OPERATING INSTRUCTIONS**

1. **STOP!** Read the safety information above.
2. Set the thermostat to the lowest setting.
3. Turn off electric power to the heater.
4. This heater is equipped with an ignition device which automatically lights the pilot. Do not try to light the pilot by hand.
5. Remove the control access door.
6. Push in gas control knob slightly and turn clockwise  to "OFF".
7. Wait five (5) minutes to clear out any gas. If you then smell gas, **STOP!** Follow "B" in the safety information above. If you don't smell gas, go to the next step.
8. Turn knob on gas control counterclockwise  to "ON"; see Figure 1.
9. Replace the control access door.
10. Turn on the electrical power to the heater.
11. Set the thermostat to the desired setting.
12. If the heater will not operate, follow the instructions "To Turn Off Gas To Heater" and call your service technician or gas supplier.

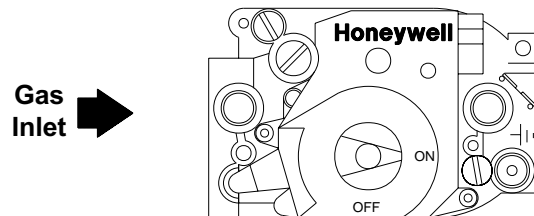



Figure 1. Gas control knob shown in "ON" position.

**TO TURN OFF GAS TO APPLIANCE**

1. Set the thermostat to lowest setting.
2. Turn off all electric power to the heater if service is to be performed.
3. Remove control access door.
4. Push in gas control knob slightly and turn clockwise  to "OFF". **Do not force.**
5. Replace control access door.



## MINIMAX CH (150 IID) ELECTRONIC IGNITION LIGHTING/OPERATION - PROPANE

### FOR YOUR SAFETY: READ BEFORE LIGHTING

#### NOTE

The MiniMax CH propane models have special features for additional safety and protection. Read the safety instructions for natural gas (page A-2) before proceeding.

### ⚠ WARNING



If you do not follow these instructions exactly, a fire or explosion may result causing personal injury, loss of life and property damage.

Since propane gas is heavier than air, escaping propane will accumulate and remain at ground level. Do not attempt to light the heater. If you suspect a propane leak, lighting the heater can result in a fire or explosion which can cause personal injury, death, and property damage.



#### WHAT TO DO IF YOU SMELL GAS

- Do not try to light matches or lighter.
- Do not try to light any heater.
- Do not touch any electrical switch; do not use any phone in your building.
- Shut off gas line at propane tank.
- Immediately call your gas supplier from a neighbor's phone. Follow the gas supplier's instructions.
- If you cannot reach your gas supplier, call the Fire Department.
- Do not tamper with the heater because it is dangerous and voids all warranties.

#### Safety Lockout:

This MiniMax CH Propane Heater is equipped with a 100% safety lockout feature. If the pilot does not light within a maximum of 90 seconds, lockout will occur.

### OPERATING INSTRUCTIONS

1. **STOP!** Read the safety information above.
2. Set the thermostat to the lowest setting.
3. Turn off electric power to the heater.
4. This heater is equipped with an ignition device which automatically lights the pilot. Do not try to light the pilot by hand.
5. Remove the control access door.
6. Push in gas control knob slightly and turn clockwise  to "OFF".
7. Wait five (5) minutes to clear out any gas. If you then smell gas, **STOP!** Follow "B" in the safety information on page 5. If you don't smell gas, go to the next step.
8. Turn knob on gas control counterclockwise  to "ON"; see Figure 2.
9. Replace the control access door.
10. Turn on the electrical power to the heater.
11. Set the thermostat to the desired setting.
12. If the heater will not operate, follow the instructions "To Turn Off Gas To Heater" and call your service technician or gas supplier.

Gas Inlet 

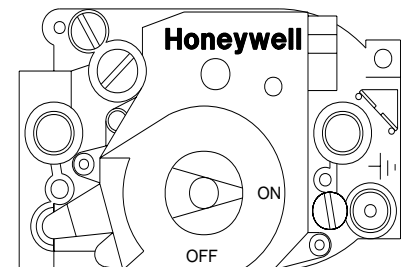



Figure 2. Gas control knob shown in "ON" position.

### TO TURN OFF GAS TO APPLIANCE

1. Set the thermostat to lowest setting.
2. Turn off all electric power to the heater if service is to be performed.
3. Remove control access door.
4. Push in gas control knob slightly and turn clockwise  to "OFF". **Do not force.**
5. Replace control access door.

## OPERATING (CONTROLS)

### Dual Temperature Control System - (Electronic and Millivolt Models)

For convenience and economy all MiniMax CH heaters are equipped with two thermostats on the front of the heater control panel; see Figure 3.

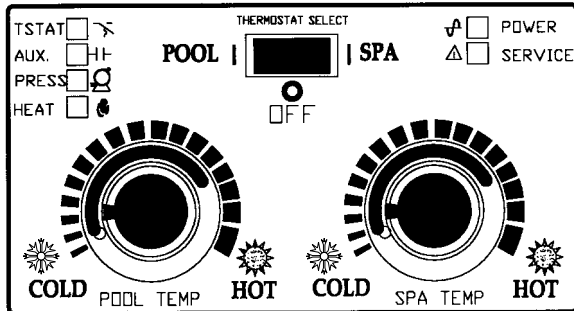

Figure 3.

#### THERMOSTAT KNOB STOPPER

Each thermostat is equipped with a mechanical stop that can be locked or unlocked with use of a screwdriver to prevent temperatures in excess of that desired by the user; see Figure 4.

The maximum setting can be adjusted by loosening the screw "A" and turning the stopper dial to desired maximum setting. Lock the setting by tightening the screw. The Mechanical stop is under the knob. Ensure that the knob is stopping at the correct position when the knob is rotated clockwise from a lower temperature position. (See Thermostat Adjustment.)

#### NOTE

**To eliminate error due to piping heat losses, measure pool temperature with an accurate thermometer directly at the pool or spa.**

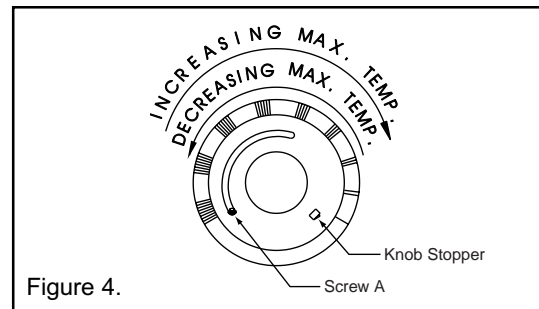

Figure 4.

#### POWER (THERMOSTAT SELECT) SWITCH

The Pool/Off/Spa switch allows the heater to be turned off when heating is not desired.

1. "Pool" position - Maintains selected pool temperature.
2. "Off" position - Heater will not come on regardless of drop in pool or spa temperature.
3. "Spa" position - This allows separate control of spa water temperature.

## INDICATOR LIGHT DESCRIPTION

The MiniMax Pool Heater provides nine status indicator lights, six can be seen from the front of the control panel which help you understand the operation of the heater. If something should go wrong, the lights will aid in troubleshooting the problem. Three additional lights can be seen after opening the control panel. These three lights give the service technician advanced troubleshooting capability. All the LED lights are green with the exception of the red service LED.

#### POWER LIGHT (POWER)

The light is on at all times, in any switch position, indicating 24 VAC power is being supplied to the control circuit. If it fails to light, no other light will be on. Possible causes are: a) external power to the heater is disconnected, check service panel circuit breaker or fuses; b) local circuit breaker inside the transformer has tripped -- investigate cause before resetting; c) transformer has failed.

#### THERMOSTAT (TSTAT)

This light is on when the thermostat contacts close, signaled by the water temperature falling below the setpoint, calling for the heater to fire to maintain the desired water temperature.

#### AUXILIARY (AUX)

This light is on when it indicates the remote switch contacts are closed. This allows you to observe if your remote switch is properly closing the heater control circuit. When shipped from the factory a jumper is installed to maintain closed circuit in the absence of a remote switch.

#### PRESSURE (PRESS)

This light is on when Spa/Pool Selector switch is on, indicates the circulation pump is running properly. If pressure light fails to light, the pump may have lost its prime or water flow may be restricted by an inadvertently closed valve or clogged filter or pump basket. If you have determined that there is no water flow restriction to the heater, you should call a qualified serviceman.

### HEAT (HEAT)

The heat light is on any time the thermostat has signaled a call for heat which initializes the ignition safety firing circuit -- the light comes on to indicate successful firing of the main burners.

### SERVICE (SERVICE)

The service light is off during normal operation of heater. The light only comes on if a problem with a control has occurred or when the heater is first firing. The problem must be investigated by the serviceman prior to attempts to fire the heater again.

The diagrams that follow give examples of troubleshooting a malfunctioning heater using the assistance of the indicator lights.



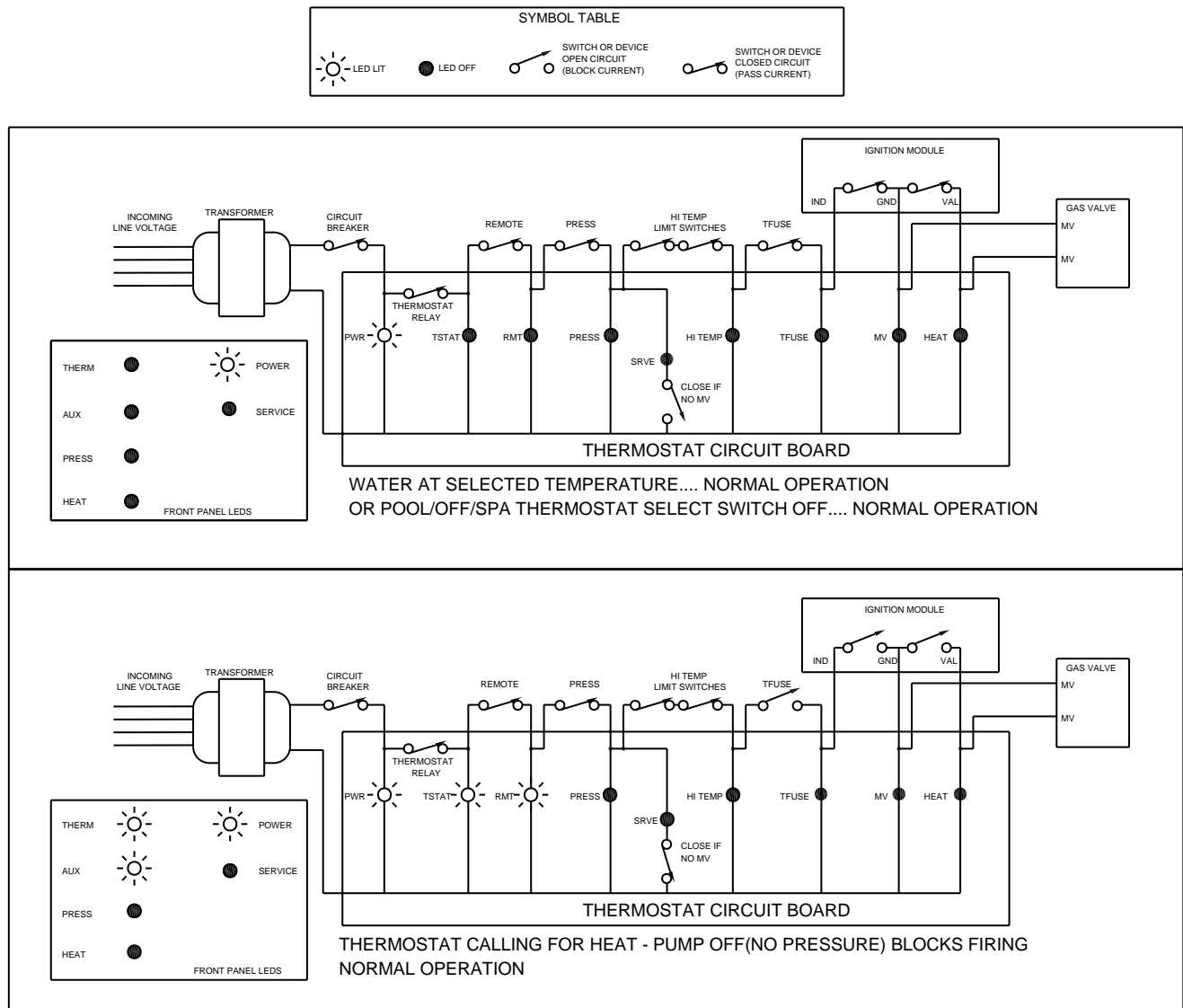

## TROUBLESHOOTING (CONTROLS)

Example of troubleshooting with the assistance of the indicator lights.



# TROUBLESHOOTING (CONTROLS) - Continued

SYMBOL TABLE

 LED LIT	 LED OFF	 SWITCH OR DEVICE OPEN CIRCUIT (BLOCK CURRENT)	 SWITCH OR DEVICE CLOSED CIRCUIT (PASS CURRENT)
---	---	---	--

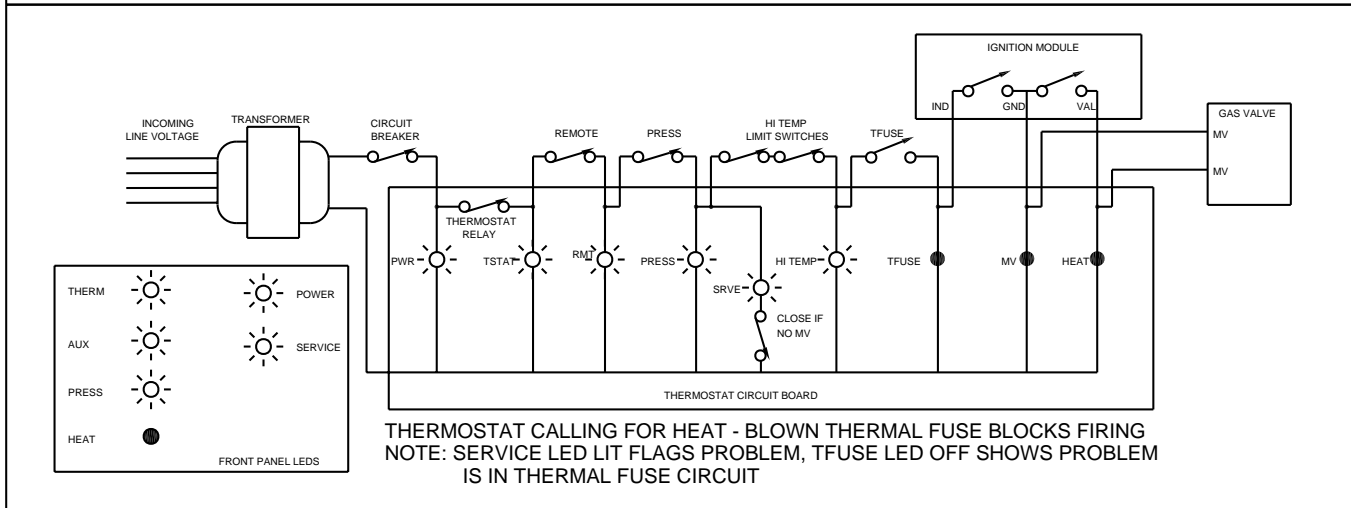
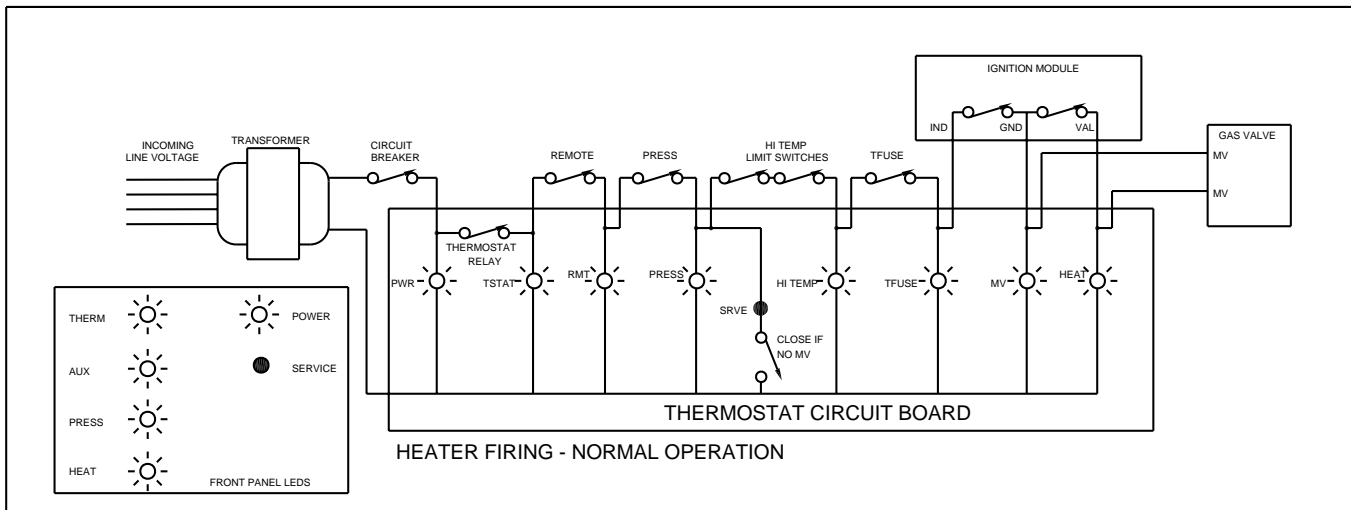

## REGULATED MANIFOLD PRESSURE TEST

1. Attach the manometer to the heater jacket.
2. Shut off the main gas valve.
3. Remove 1/8 in. NPT plug on the outlet side of the valve and screw in the fitting from the manometer kit.
4. Connect the manometer hose to the fitting.
5. Fire the heater.
6. The manometer must read 4 in. WC for natural gas, 11 in. WC for propane gas, **while** the heater is operating.
7. For adjustment, remove the Regulator Adjustment Cap and using a screwdriver turn the screw clockwise to increase - counterclockwise to decrease gas pressure.

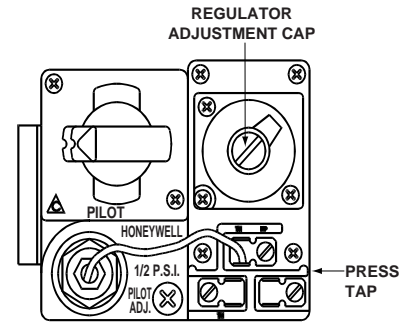
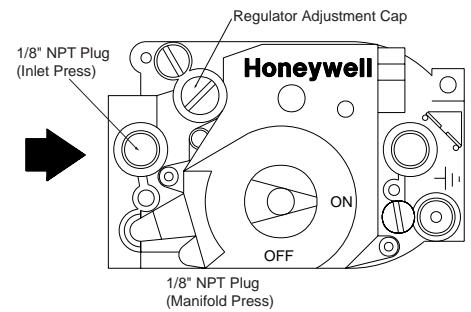

## ELECTRICAL, IID ELECTRONIC UNITS

### Electrical Rating

60 Hz	115 V.A.C. or 230 V.A.C.
50/60 Hz	208 V.A.C. or 240 V.A.C.

### NOTE

If any of the original wiring supplied with this heater must be replaced, installer must supply (No. 18 AWG 105° C. U.L. approved AWM low energy stranded) copper wire or it's equivalent.

**In Canada:** wires must be CSA approved.

### **⚠ WARNING**

The heater must be electrically grounded and bonded in accordance with local codes or, in the absence of local codes, with the latest national electrical codes ANSI/NFPA No. 70.

**In Canada:** CSA standard C22.1 Canada Electrical Code Part 1 and/or local codes.

Always use crimp type connectors when connecting two wires.

This heater is equipped with a reversible junction box to allow line voltage to be wired from either side.

## Transformer Wiring Instruction

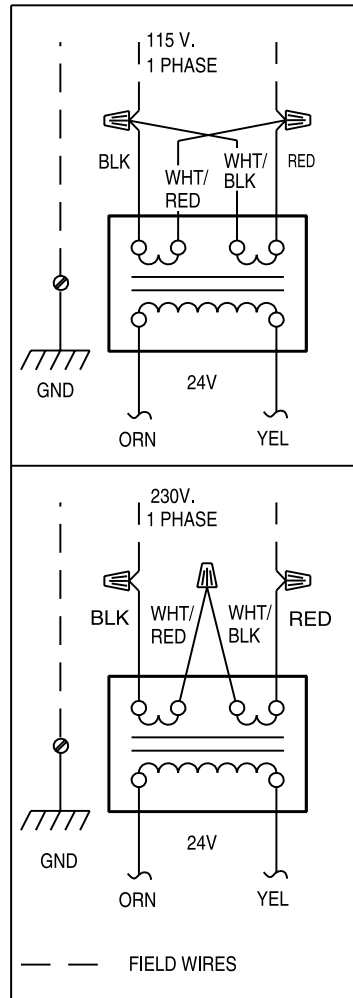

Figure 5.

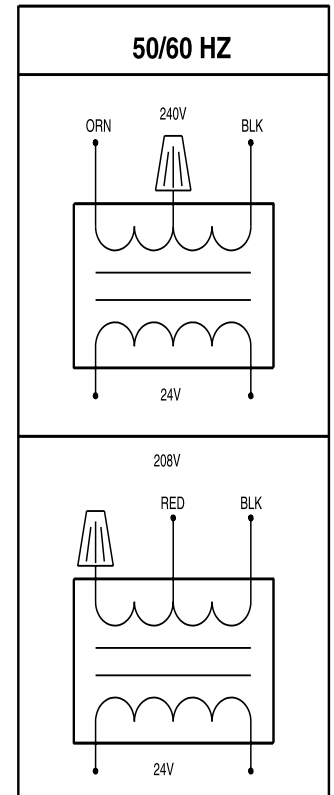

Figure 6.

# MiniMax CH (150 IID Model) Electronic Ignition Wiring Diagram

## MiniMax CH 150 IID Wiring Diagram

IF ORIGINAL FACTORY WIRING MUST BE REPLACED, INSTALLER MUST SUPPLY UL OR CSA (IF CANADA) APPROVED WIRE, 18 GAUGE, 600V, 105 C TEMPERATURE RATING. THERMAL FUSE WIRING MUST BE REPLACED WITH UL OR CSA (IF CANADA) APPROVED WIRE, 18 GAUGE, 600V, 125 C TEMPERATURE RATING. INTERCONNECTING WIRING TO APPLIANCE MUST CONFORM TO THE NATIONAL ELECTRICAL CODE OR SUPERCEDING LOCAL (WIRING) CODES.

TERMINATE SUPPLY SAFETY GROUND WIRE (GREEN) HERE  
GROUND SCREW WITH PAINT CUTTING WASHER  
CHASSIS SHEET METAL

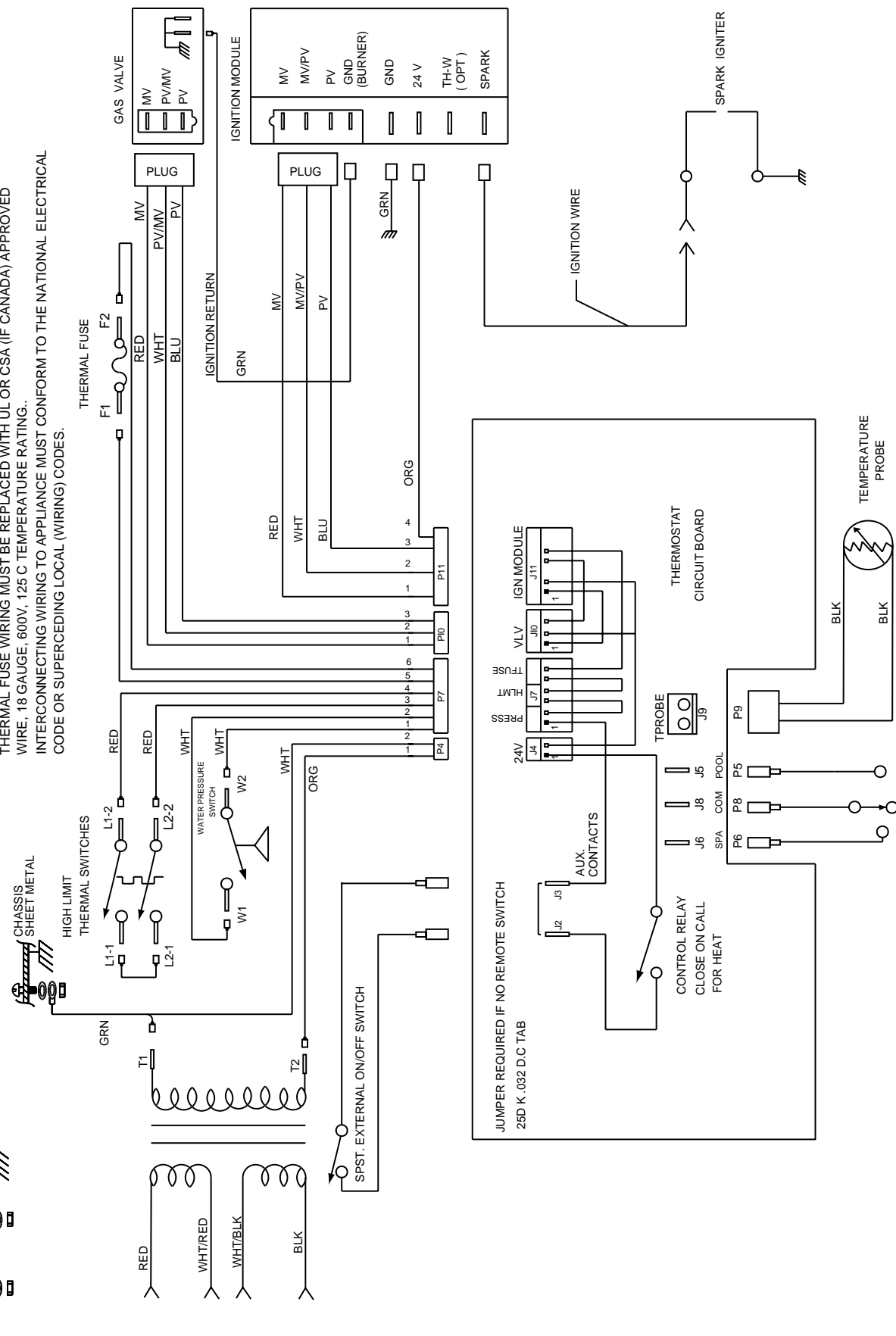
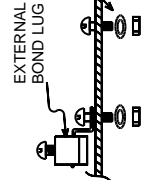

POOL OFF SPA  
THERMOSTAT SELECT SWITCH

### REMOTE SWITCH DUAL THERM IID ONLY

#### 3 Wire Remote

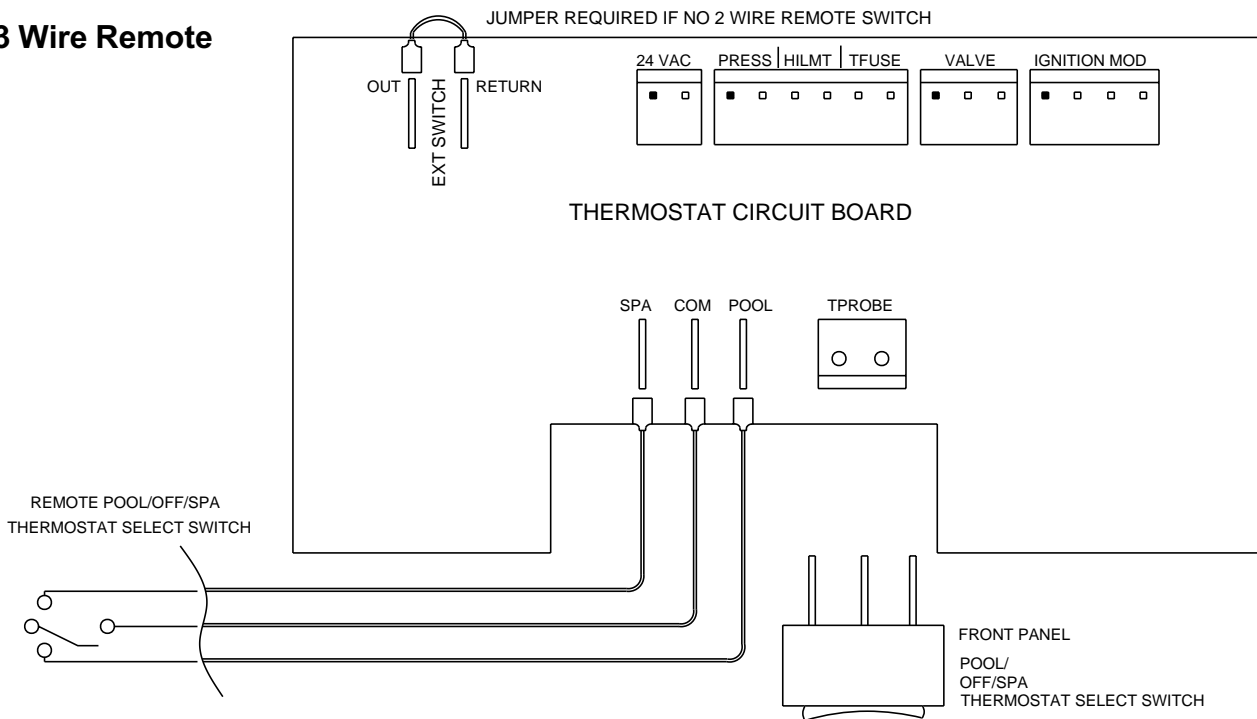

Figure 7.

#### 2 Wire Remote

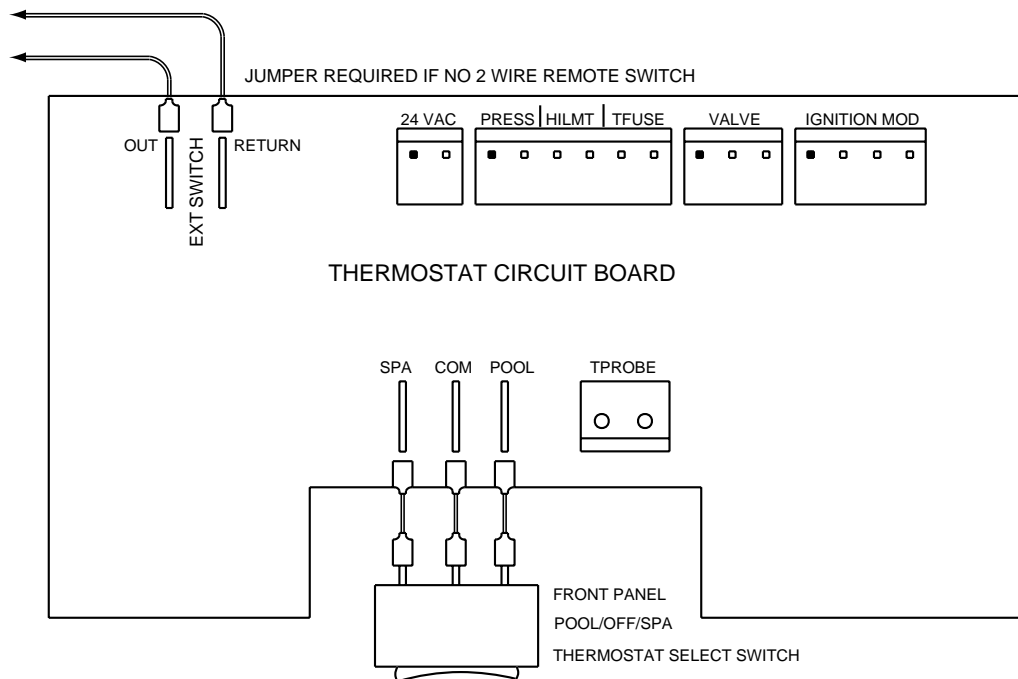
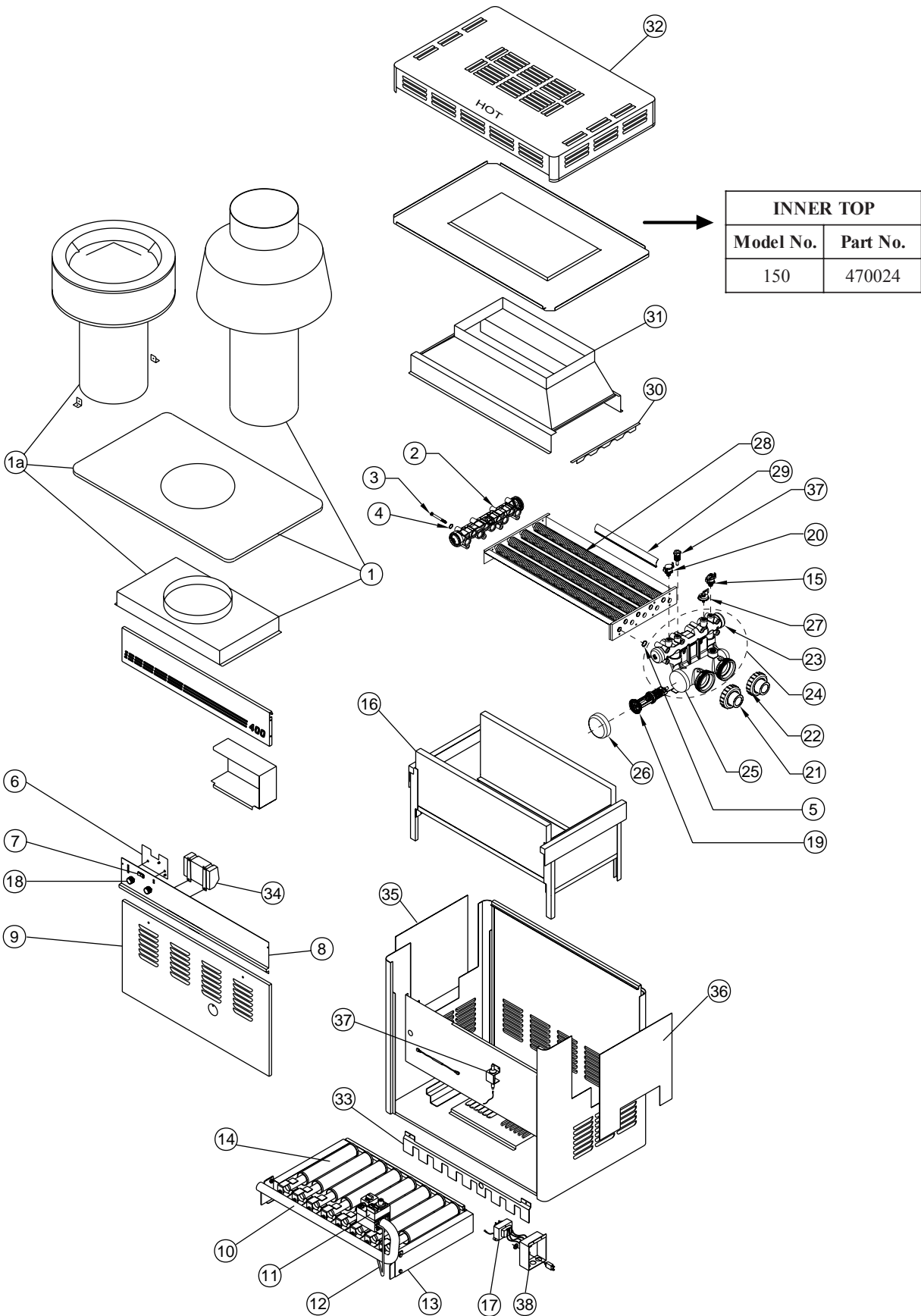

Figure 8.

**NOTE:** When connecting a remote control to the MiniMax CH, you must install the low voltage thermostat wires in separate conduit from **ANY** line voltage wires. Failure to follow these instructions will cause the thermostat relay to react erratically.

# MINIMAX CH HEATER - 150 IID MODEL





## MiniMax CH Parts List - 150 IID Model

ITEM	DESCRIPTION	QTY	150
1	Vent kit assy. (indoor)	1	460227
1a	Vent kit assy. (outdoor)	1	460237
2	Return header	1	070994
3	Bolt, heat exchanger	16	471991
4	Washer 3/8" ID 1" OD	16	072184
5	Tube seal gasket	18	070951
6	Electronic Thermostat circuit board - IID Model	1	470179
7	Switch rocker (single pole & double throw)	1	470186
8	Control panel assy. (complete) - IID Natural	1	472151
	Control panel assy. (complete) - IID Propane	1	472191
9	Door - Millivolt or IID	1	075468
10	Manifold burner	1	070256
11	Gas valve Natural - IID	1	073998
	Gas valve Propane - IID	1	073999
12	Pilot tube - IID		075191
13	Burner tray assy. Natural (complete) - IID	1	073752
	Burner tray assy. Propane (complete) - IID	1	073906
14	Burner		2 EA. 070230
14a	Burner with pilot bracket (not shown)	1	470550
15	Pressure switch	1	471672
16	Combustion chamber assy. (complete)	1	073858
17	Transformer - w/circuit breaker - dual voltage	1	471360
18	Thermostat knob	2	470184
19	Flow valve assy.	1	471750
20	Hi-Limit thermostat 115°	1	471587
21	Adaptor - bulkhead, 2 in.	2	471441
22	Adaptor - bulkhead ring	2	274440
23	Main manifold assy.	1	471993
24	Main header assy.	1	471992
25	Main manifold bottom	1	471419
26	Cap, main manifold bottom	1	471420
27	Hi-Limit thermostat 150°	1	471694
28	Heat exchanger (without heads)	1	472131
	Heat exchanger (with heads)	1	472169
29	Baffle		8 ea. 070277
30	Baffle hold down (2) baffles on 400	1	073810

## MiniMax CH Parts List - 150 IID Model, *contd.*

ITEM	DESCRIPTION	QTY	150
31	Flue collector	1	073864
32	Outdoor top assy.	1	470471
33	Lightback shield (Propane Gas units only)	1	075783
34	Module Natural Gas	1	073584
	Module Propane Gas	1	073585
35	Panel (return)	1	073789
36	Panel (in/out)	1	472127
37	Thermistor (probe) complete - IID	1	471566
38	Junction Box	1	470122
<b>* Not Shown</b>			
*	Plastic mounting bracket		070715
*	Clips for wire harness		471277
*	Wire Kit - Millivolt		075511
*	Screw 8 x 1/4" HH		071703
*	Screw 8 x 1/2" HH		071698
*	Screw 6 x 1/4"		071716
*	Screw 10 -32 x 1/4"		071659
*	Screw 10-32 x 3/16		075692
*	Bushing 1/2"		070551
*	Therm knob stopper	2	470414
*	Bolt 5/16" - 18 x 3/4'	2	073725
*	Orifice main burner natural		3 ea. N or P 073727
*	Orifice main burner propane		073728
*	Pilot - natural - Millivolt	1	471292
*	Pilot - propane - Millivolt	1	471291
*	Pilot - generator	1	071515
*	Thermal cutoff - fusible link	1	075173
*	Power element (flow-valve)	1	470178
*	Pilot rainshield	1	471293
*	Pilot electrode (only)	1	471328
*	"L" brackets	3	074540
*	Bracket adapter Q379 pilot, MV		471271
*	Jumper		072253
*	Door latch		071240





Because *reliability* matters most

## MiniMax<sup>®</sup> CH Heaters Limited Warranty

Your MiniMax CH pool heater is another quality product from Pentair Pool Products, Inc. and is backed by the following warranty.

1. The following parts are warranted for 5 years from date of purchase:

The MiniMax CH cabinet and combustion chamber, the main burners and burner manifold, the inlet/outlet header and the return header. This warranty does not cover rusting or corrosion on cabinets or burners that does not affect the heater's operation.

2. The following parts are covered for 2 years from date of purchase:

The automatic flow control valve, all controls, heat exchanger, pilot generator and the pilot assembly.

This warranty only applies to the original purchaser.

3. This warranty shall not apply to any units or parts which have been subject to accident, negligence, alteration, abuse, misapplication or misuse.

The above warranty applies only if the heater is installed and operated in complete compliance with the installation and operation manual provided with each unit. Copies of this manual are available by writing to Pentair Pool Products, Inc., at the address below.

Pentair Pool Products, Inc. assumes no liability except for the repair or replacements of parts as specified above. Ship defective parts or equipment along with serial number and purchase date, transportation prepaid to the address below. Purchaser shall be responsible for freight charges for return of merchandise to purchaser. Some states do not allow exclusion or limitation of incidental or consequential damages so the above may not apply to you.

This warranty gives you specific legal rights, and you may also have other rights which vary from state to state.

**HEATER SERIAL NUMBER**

(Please Fill In)

**Pentair Pool Products, Inc.**  
1620 Hawkins Ave., Sanford, NC 27330 • (919) 774-4151  
10951 W. Los Angeles Ave., Moorpark, CA 93021 • (805) 523-2400