



CS 299 XL & CS 299M XL*

(*: Avec frein de positionnement d'agrafage)
(* Equipped with lock button for stapling position)



Technical and User Manual Manuel Technique et d'Utilisation

Version 1 du 02 / 2006

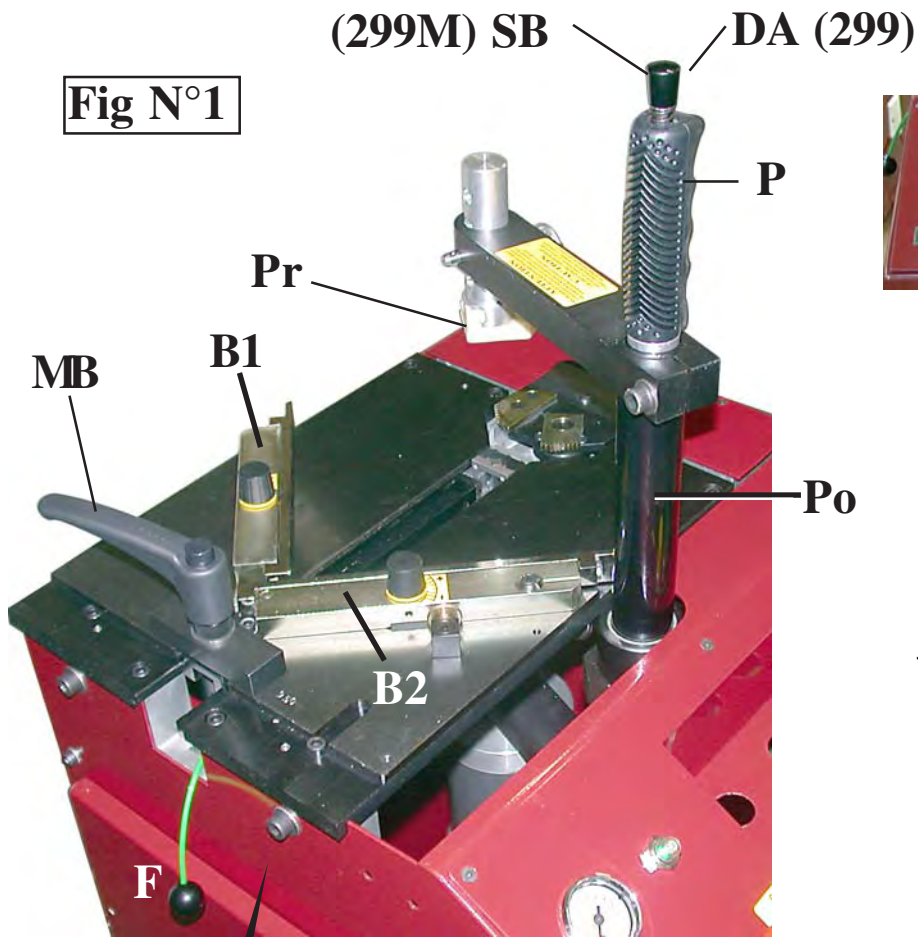

Fig N°1



Fig N°2

WORK POSITION

Fig N°3

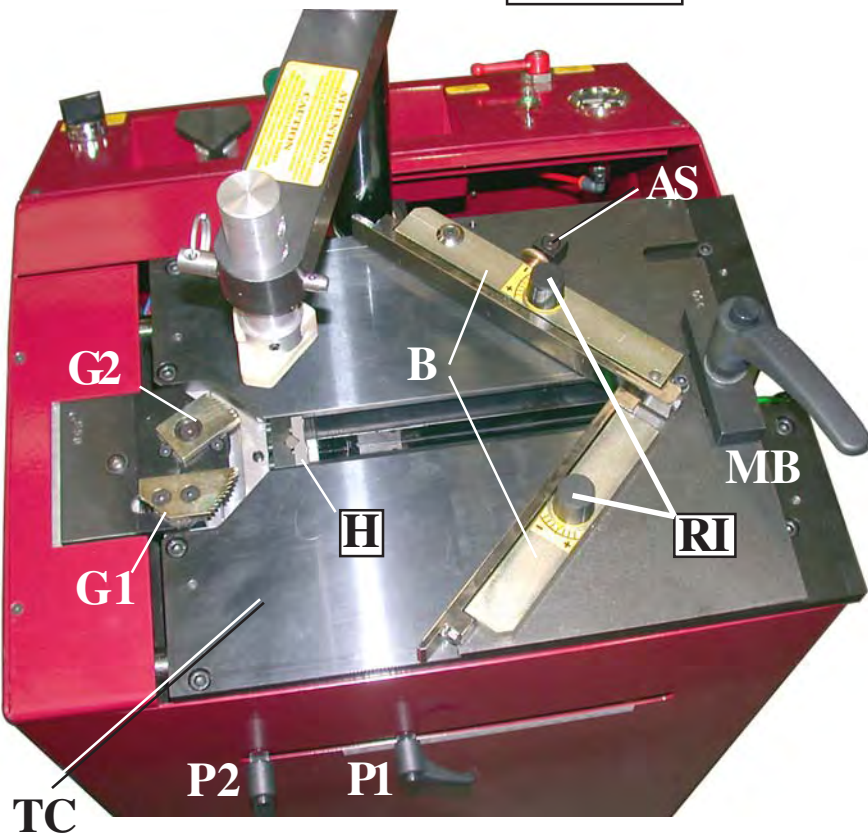

ANGLE ADJUSTMENT SCREW	AS
BACKFENCE	B1
BACKFENCE	B2
STAPLING BUTTON	SB
LOCK BUTTON FOR STAPLING POSITION	DA
WIRE FOR WEDGE PUSHING SPRING	F
CLAMPS	G1 G2
WEDGE DISTRIBUTOR	H
SLIDING TABLE	TC
BLOCKING LEVER	MB
BLOCKING LEVER FOR STAPLING POSITION	P1
BLOCKING LEVER FOR 2 nd STAPLING POSITION	P2
STAPLING BUTTON HANDLE	P
CLAMP POSITION BUTTON	PG
TOP PRESSER BRACKET	Po
TOP PRESSER	Pr
FENCES INCLINATION ANGLE ADJUSTMENT	RI

CS 299 & M XL

PNEUMATIC FRAME
ASSEMBLING MACHINES

INTRODUCTION

ACCESSORIES SUPPLIED WITH THE MACHINE	2
TECHNICAL SPECIFICATIONS	2
OPTIONS	2
GUARANTEE	2

PUTTING INTO OPERATION

- Reassembly	3
- Connecting the machine to air supply	3

ADJUSTMENTS

- Adjustment of the sliding table	4
- Selection of stapling positions	4
- Setting and storing the stapling position	5
- Selection of top presser end	6
- Using the set of spacer bars	6
- Adjustment of the inclination of fences	6
- Adjustment of the assembly angle	7

USE

- Means of assembly	8
- Loading and changing the wedge cartridge on machine	8
- Joining the frame	8

MAINTENANCE

LUBRICATION	9
CLEARING OF A WEDGE STUCK IN THE WEDGE DISTRIBUTOR	9
IN CASE OF HAMMER AND WEDGE JAMMING	10
DISMOUNTING THE SLIDING TABLE	11
GENERAL ADVICE	11

INTRODUCTION

You have just bought a CS 299 / M XL pneumatic joining machine, so we congratulate on your sensible choice and thank you for your trust in Cassese products.

The CS 299 / M XL benefits from the experience of the joining machines that brought Cassese a certain reputation. It makes it possible to join wooden mouldings of all profiles (patent n° 7522814).

The CS 299 / M XL is designed to allow the operator to move all around the machine.

The joining operation is carried out by using metal wedges especially designed to perform a tight join. These wedges come in throw-away plastic cartridges, without glue, individually lubricated and rust-protected for the toughest challenges.

IMPORTANT : You should not use other wedge cartridges than those developed by Cassese (registered mark CS)

ACCESSORIES SUPPLIED WITH THE MACHINE

- Spacer bars for small mouldings,
- 1 triangle supports Z 6532 with: 1 black rubber triangle (hard), 1 white triangle (soft)
- 1 round rubber supports Z 15855 with - according to the moulding shape :
 - | 2 green rubber ends for hardwood types (1 short and 1 long)
 - | 2 orange rubber ends for soft wood types (1 short and 1 long)
- 1 spare hammer + 1 grease tube,
- 3 Allen keys for hexagonal nuts (2,5 - 3 - 5 mm) / 1 wedge pusher tool,
- 4 feet (on the machine) , 2 stapling stop levers, 1 Ball lock,
- 1 table handle/ 1 quick release female air connection,
- 1 handle/ 1 lock button with its long rod,
- 1 key for machine door

TECHNICAL SPECIFICATIONS OF CS 299M XL

- Minimum moulding width : 5mm (3/16") - maximum width : 150 mm (6")
- Minimum moulding height : 7 mm (1/4")- maximum height : 112 mm (4 1/2")
- Minimum dimensions of a frame : 85 mm x 85 mm at sight (3 1/2" x 3 1/2").
- Wedge sizes in cartridges of 275 pieces : 3, 4, 5, 7, 10, 12 and 15 mm.
- Two wedge types : for soft and for hardwoods.
- Machine weight : 80 kg (177lbs)
- Dimensions : W 850 mm x L 490 mm (without optional rotating table)x H 1130 mm
- Pneumatic supply : compressed air 7 bar (100 psi),
- Average consumption : 5 litres per cycle.
- Air conditioning : air pressure reducing valve + manometer, connecting pipe, inside diameter 8 mm.

OPTIONS

- Independent rotating table, diameter 1300 mm (50 1/4") to make the handling of large frames easier (frame dimensions not exceeding table diameter).
- Set of furniture clamps to join mouldings without rebate and/or small frames.
- Angle inserts for 6-sided frames or for other forms on request.

GUARANTEE

One year guarantee for parts and labour against manufacturing defects. Wear parts and those damaged as a result of non appliance with the instructions of the present manual are excluded from the guarantee.

PUTTING INTO OPERATION

REASSEMBLY

- 1) Level the machine by means of the adjustable feet (flat spanner n° 20 mm).
- 2) Remount handles MB, P1, P2 (fig.3, page 1) replacing the transport screws, without locking them.
- 3) Free the grease tube fastened inside the machine.
- 4) Screw on the handle P in top presser bracket Po and introduce the rod of the lock button DA in it (fig.3 p1).

Remark : For all explanations given in the present manual for adjusting and putting into operation, we considered the user is standing **BEHIND THE MACHINE** as indicated figure 3, page 1 : work position.

CONNECTING THE MACHINE TO AIR SUPPLY

- 1) Inside the machine (see below), connect the compressor air inlet pipe by using the quick release female connection supplied with the machine ;
 - 2) Connect air compressor.
 - 3) Fasten blast pipe onto the compressed air pipe by crossing the metallic wall through the side hole in order to make air bleed occur outside the machine.
- Make sure pressure in manometer is equal to 7 bars (100 psi).

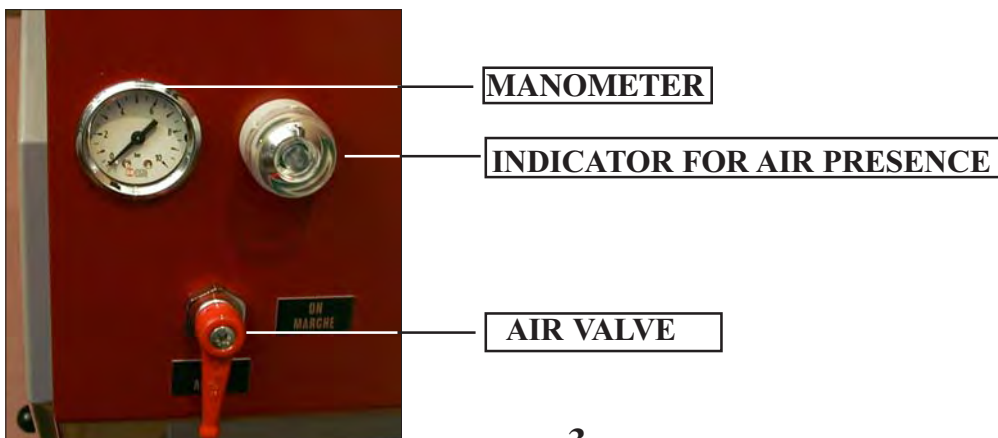
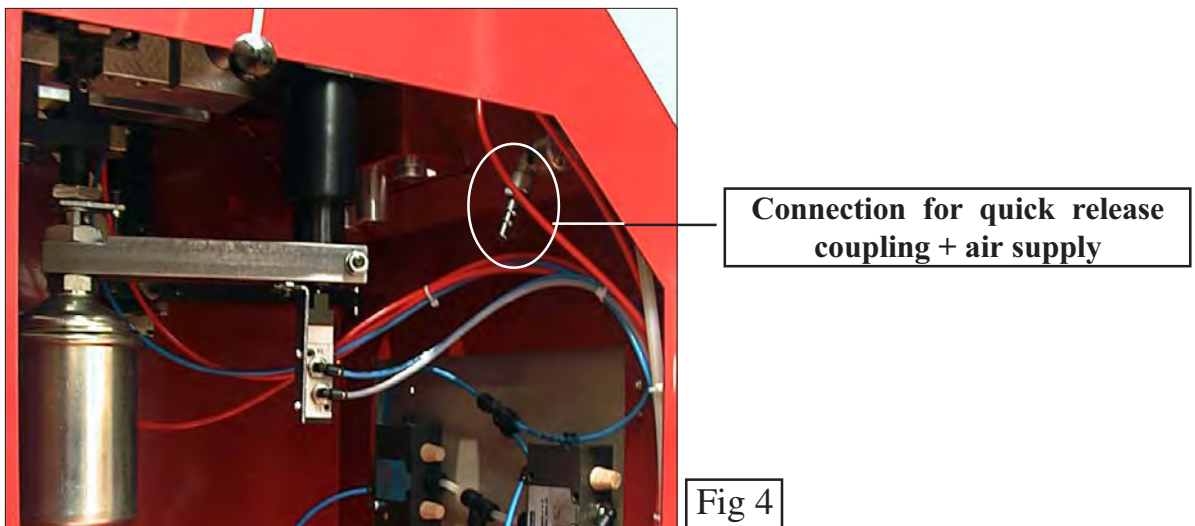

ADJUSTMENTS

ADJUSTMENT OF THE SLIDING TABLE (Fig.1, TC)

- 1) Turn to ON the clamp position button PG (fig2, p1) to make the clamps (G1 and G2) move forward.
- 2) Make sure the two inclination adjustment knobs RI of the backfences (fig 1 p1) are at zero.
- 3) Position a moulding against left hand fence B1 (for mouldings with a height smaller than the fence, use the spacer bars supplied with the fittings by slipping them between the fences and the small mouldings).
- 4) Move sliding table TC (fig1 p1) forward as far as the clamp G1 (fig1 p1) comes into contact with the moulding.
- 5) Tighten the sliding table blocking handle MB (fig1p1).
- 6) Turn to OFF the clamp position button PG (fig2, p1)

SELECTION OF STAPLING POSITIONS

The CS 299/M XL is designed to join mouldings in one or two places (positions) without limitation of the number of wedges in any of those places. The selection depends on the width and thickness of the moulding to join. If needed, additional positions can be inserted between these two positions .

2 mm MINIMUM

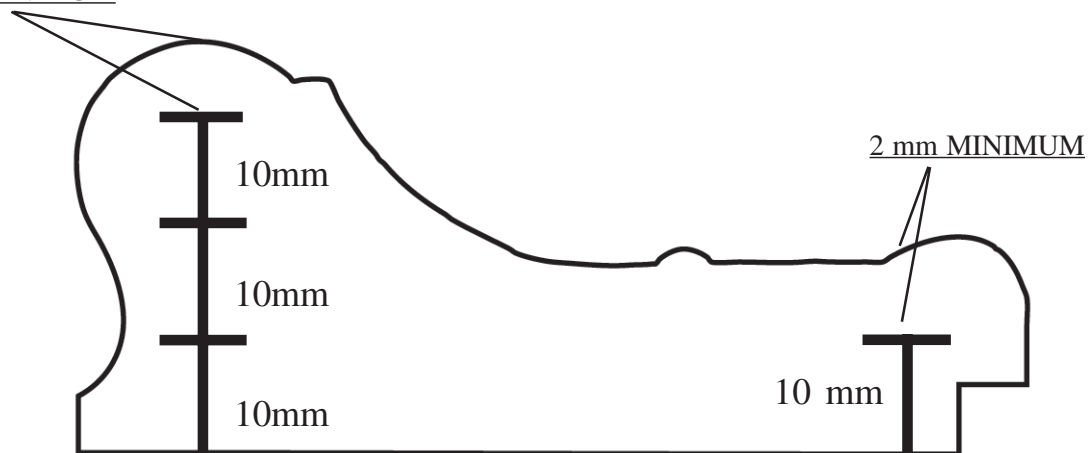

As a general rule a MINIMUM 2 mm clearance (less than 1/8") above the wedges shall be respected.

Same sized wedges can be stacked in order to avoid to have to change the cartridge size when joining frames with different thickness.

AS A GENERAL RULE, THE JOINING MUST BE CARRIED OUT AS CLOSE TO THE THICKEST MOULDING PART(S) AS POSSIBLE .

SETTING AND STORING THE STAPLING POSITIONS

Unlock the stapling position lock handles P1, P2 (fig3p1).

For the stapling position close to the outside of the frame :

Press the button DA to unlock and slide the top presser bracket **Po** (fig 3, p1) with your right hand as far as the stapling position selected has been reached. The wedge distributor **H** (fig1) moves at the same time underneath of the moulding and its wedge exit slot shows you exactly the position reached. Holding the bracket in position with your right hand, slide with your left hand the handle **P1** forward in stop position and tighten it.

For the stapling position close to the inside of the frame :

Press the button DA again and slide the top presser bracket **Po** forward until it reaches the position chosen for the insertion of the wedge(s) inner frame side. Release now the button DA to lock the position and slide the handle **P2** (fig3, p1) towards yourself until it reaches the stapling position chosen and tighten it.

SELECTION OF A TOP PRESSER END

2 top pressers comes now with your CS 299 as a standard feature. They adapt themselves on the plunger head thanks to the pin G and can be set up in 4 to 6 positions from the table. Pay attention to position well the triangle : the sides of the triangle must be parallel to stops B1 and B2 (see fig1 page A)

BLACK TRIANGLE PRESSER	HARD WOOD
WHITE TRIANGLE PRESSER	SOFT WOOD
GREEN RUBBER TIPS	HARD WOOD 30 and 45 mm
YELLOW RUBBER TIPS	SOFT WOOD 30 and 45 mm

Triangle top pressers are good for flat mouldings or for mouldings presenting a flat or horizontal area to come down on. The round rubber ends are good for complicated forms (uphill, downhill or reverse mouldings).

LOCATING THE TRIANGLE TOP PRESSER

The moulding height capacity of the new triangle top presser support for its 4 positions :

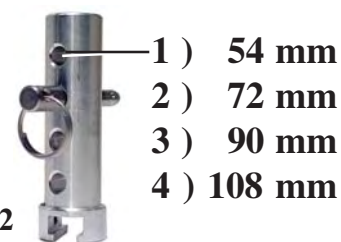
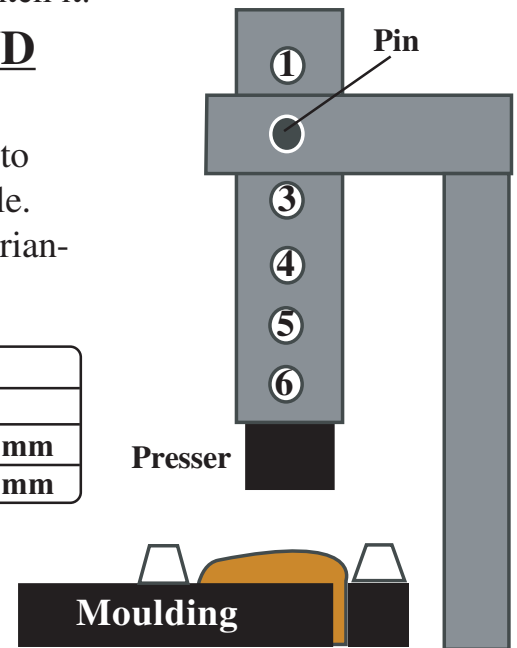

- 1) 54 mm
- 2) 72 mm
- 3) 90 mm
- 4) 108 mm

Z15852

LOCATING THE ROUND RUBBER TOP PRESSER

A similar adjustable support for the round rubber top pressers is now available with 6 positions for its height. As the round rubbers are available in two lengths (30mm & 45mm) and in two hardness finishes (orange for softwoods & green for very hardwoods), the maximum height of moulding that this optional round rubber support can work in its 6 positions are :

MAXIMUM HEIGHT FOR THE MOULDINGS



Z15855

Position hole #	With short round rubber	With long round rubber
1	20 mm	05 mm
2	36 mm	21 mm
3	52 mm	37 mm
4	68 mm	53 mm
5	84 mm	69 mm
6	100 mm	85 mm

USING THE SET OF SPACER BARS

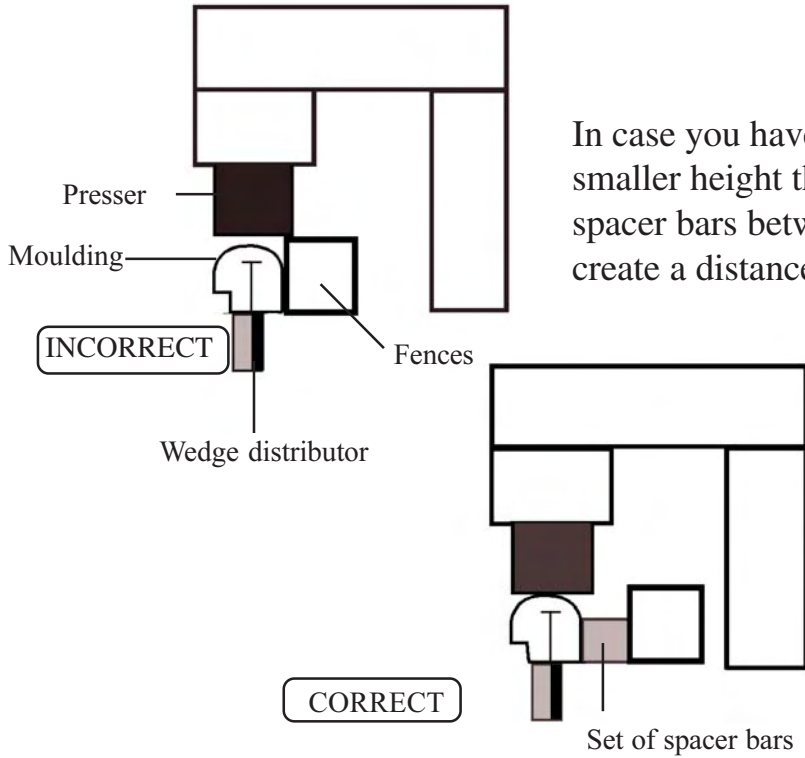

In case you have to join small mouldings with a smaller height than the fences, you must put the spacer bars between the mouldings and the fences to create a distance.

ADJUSTMENT OF THE INCLINATION OF THE FENCES

SETTING SCREW FOR THE ASSEMBLY ANGLE

ADJUSTMENT BUTTON FOR THE INCLINATION OF THE FENCES

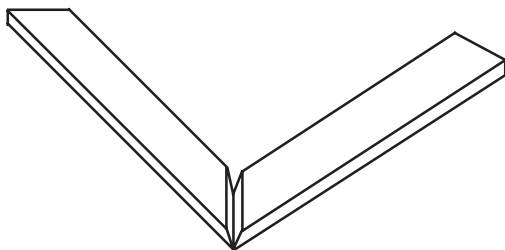
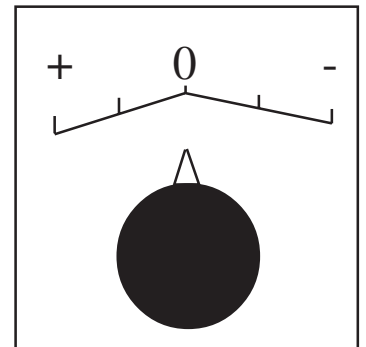
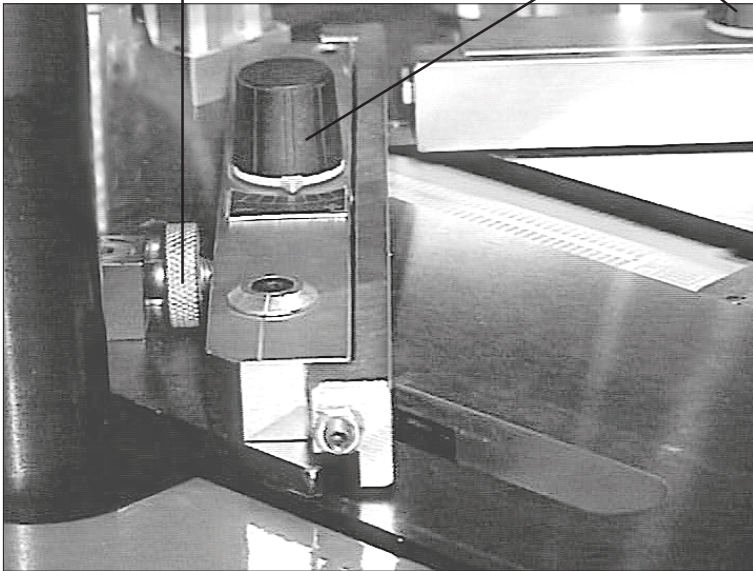

If the corner has an opening on top, turn the two adjustment buttons (RI) an identical value to the MINUS (-) (fig 1 p1) until the opening disappears when mouldings are clamped.

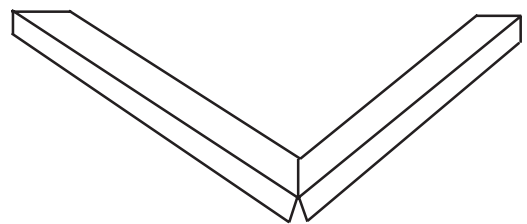

If the corner has an opening **underneath**, turn the same two adjustment buttons (RI) an identical value to the PLUS (+) (fig 1 p1) until the opening disappears when mouldings are clamped.

ADJUSTMENT OF THE ASSEMBLY ANGLE

If several cutting machines are being used in your production or if you receive your mouldings already cut by your suppliers (chop service), the angles of the mouldings will be slightly different from one cutting machine to the other.

The joining angle of your CS 299M XL can be adapted to find precisely the cutting angle of your cutting machine.

If the corner is open towards outside, screw in the adjustment screw (see photo page 6) for the assembly angle AS (fig 1 p1) to correct the fault and check the quality of the angle by clamping the corner again.

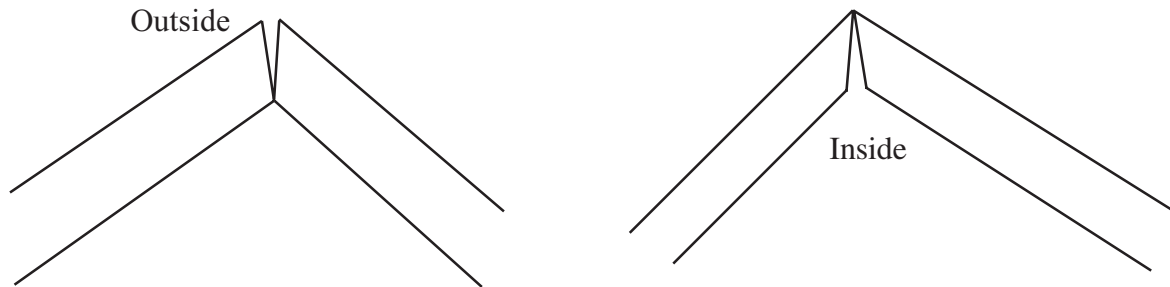

If the corner is open towards inside, unscrew the angle adjustment screw AS (fig 1 p1) to correct the fault and check the quality of the corner by clamping the mouldings again.

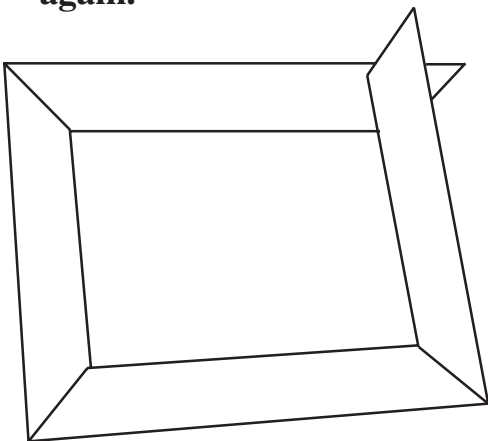

If you get this result, check your cutting angle, which is wrong in this case because it is less than 45° .

Carry out the adjustment of the angle of your cutting machine.

IT IS IMPOSSIBLE TO MAKE A RECTANGLE FRAME WITH ANGLES SMALLER THAN 90° .

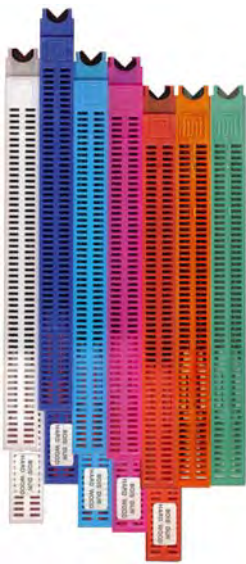

USE

MEANS OF ASSEMBLY

The joining is performed by using metal wedges, a Cassese invention, designed to ensure very tight corners. Five sizes are available : 5, 7, 10, 12 and 15 mm. They come in throw-away cartridges that are colour-coded per size for easy identification. Cartridge wedges exist in two versions : **NORMAL** for soft and normal timbers and **HW** for very hard timbers. These hardwood wedges are to be used only on hardwoods. Your CS 299M XL machine is designed to use all sizes of Cassese cartridges without having to change any parts on the machine or having to adjust anything. For the long term performance and reliability of your CS 299M XL, only use genuine CASSESE cartridge wedges.

LOADING AND CHANGING THE WEDGE CARTRIDGE ON MACHINE

Pull the wire with ball of the wedge pusher spring **F** (fig.3, p1) fully out. If there is a cartridge on machine, holding the wire pulled out, remove it by simply sliding out the cartridge. Holding the wire pulled out, put a new cartridge on machine and pay attention that it is fully inserted in the wedge distributor's window. Release gently the wire with ball of the wedge pusher spring **F**.

JOINING THE FRAME

- 1- After adjusting the sliding table, selecting and setting the stapling positions, selecting the best suited top presser end, (see chapters)
- 2- Put the first moulding in front of the fence B1 and push it so that its mitre end reaches the other fence B2. Holding it so, put the second moulding chop against fence B2 and slide it until it reaches the first moulding.

CS 299M XL

- 3- Holding the mouldings in place, press only half way on the foot pedal to clamp the mouldings and to check visually the quality of your corner. (If needed, carry out the adjustment of the assembly angle and the inclination angle of the fences (see those chapters) to reach the best quality corner, before inserting wedges.)
- 4- If the corner is satisfactory, maintain the foot pedal pressed half way and press on the lock button DA (fig.3, p.1) to release the top presser bracket and slide it to one of the stapling position chosen. Release the button DA to lock the position.
- 5- Press now fully on the foot pedal to insert the first wedge in this position. If a second (or third) wedge must be inserted and stacked in the same position, release the foot pedal half way and press fully again.
- 6- For a second (or more) position where the wedges must be inserted, press again the button DA and slide the top presser to this position, release the foot pedal half way, and press fully again to insert the wedge. For a second wedge, repeat the operation of releasing the foot pedal half way and pressing fully down.

WHILE INSERTING A WEDGE BY PRESSING THE FOOT PEDAL FULLY DOWN, IT IS IMPORTANT NOT TO RELEASE THE FOOT PEDAL TOO QUICKLY BEFORE A COUPLE OF SECONDS, LEAVING TO THE MACHINE THE TIME MECHANICALLY NEEDED TO INSERT THE WEDGE FULLY IN AND TO FINISH THE CYCLE.

CS 299 XL

- 3- Holding the mouldings in place, push the foot pedal to clamp the mouldings and to check visually the quality of your corner.
- 4- If needed, carry out the adjustment of the assembly angle and the inclination angle of the fences (see those chapters) to reach the best quality corner, before inserting wedges.
- 5- If the corner is satisfactory, **maintain the foot pedal pressed during the whole work with this corner**.
- 6- Slide the top presser bracket to one of the stapling positions chosen and press the stapling button SB (fig.3) to insert the first wedge. **Keep the stapling button pushed until the end of the cycle**. If a second wedge must be inserted and stacked in the same position, holding the bracket firmly in position by its handle, release the stapling button and push it once again. Keep the button pressed every time until the end of the cycle.
- 7- Slide the top presser bracket to the next stapling position and repeat point 6 above.

MAINTENANCE

**BEFORE ANY MAINTENANCE INTERVENTION,
CLOSE THE AIR VALVE OF THE MACHINE**

1) LUBRICATION

Periodically, remove the wedge distributor (block H) and clean it (by air gun) without dismounting it.

It is recommended to lubricate the hammer (driver blade) periodically. To do so, remove the wedge distributor (block H) and put a small quantity of grease (a tube of grease is with accessories of the machine) in the bottom hole of the wedge distributor. The hammer will be lubricated every time it crosses the wedge distributor.

2) CLEARING OF A WEDGE STUCK IN THE WEDGE DISTRIBUTOR

If you release the stapling button during the cycle or if you lift the top presser bracket accidentally, a wedge may be half engaged in the wedge distributor. In this case,

- Close the air valve.
- Try to remove the cartridge that is in position. If it resists, use the wedge removal tool to push down the wedge back in the cartridge.
- Pay attention not to make penetrate the tool more than 6mm (1/4") into the wedge distributor.
- In case of the hammer (driver blade) jamming with a wedge in the wedge distributor, see the following section (3).

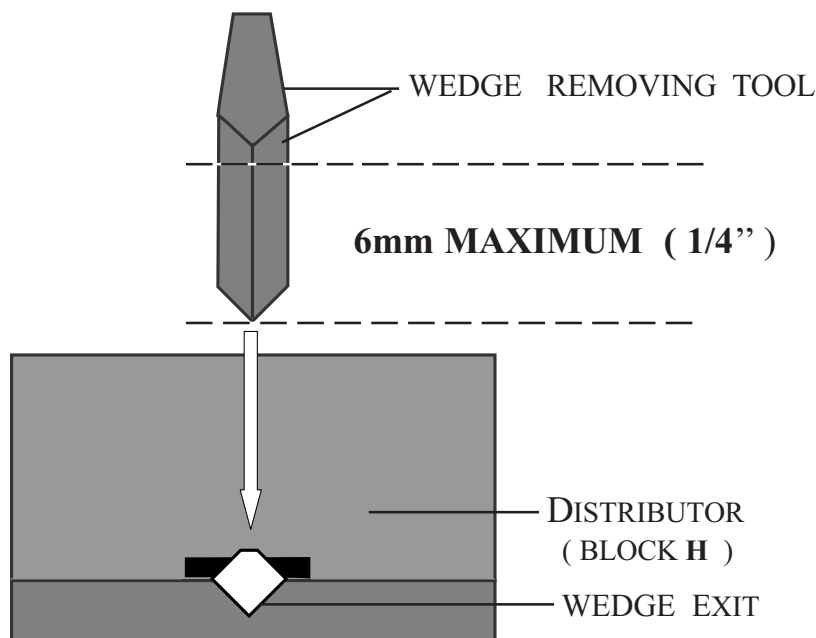

MAINTENANCE

**BEFORE ANY INTERVENTION,
CLOSE THE AIR VALVE**

3) IN CASE OF HAMMER AND WEDGE JAMMING

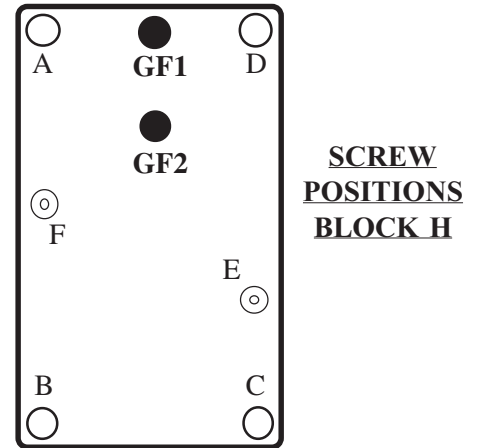
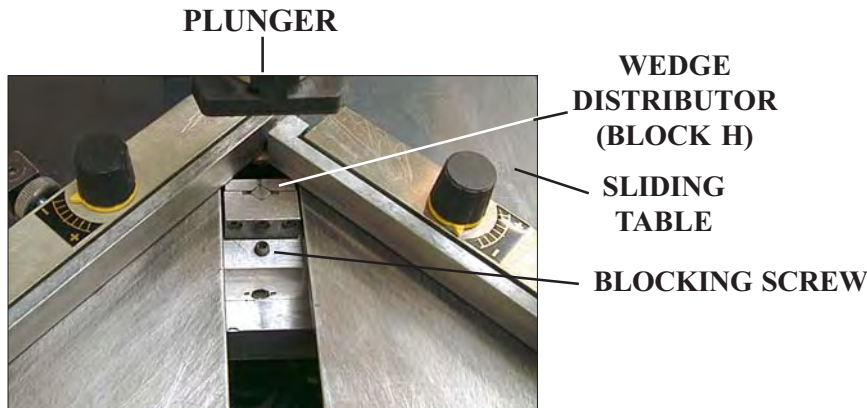

- Remove the cartridge that is on machine.
- Using the 3mm Allen key, loosen the locking screw of the wedge distributor Block H.
- Then lift the top presser's bracket arm by hand. The wedge distributor will come out of its housing.
- Remove it from the machine.
- The old hammer (wedge driver blade) is stuck in the wedge distributor : first try to remove it with a pair of pliers. If not possible, unscrew the two central screws (**GF1, GF2**) that hold the fixed (square) guide of Block H in place. Use for this the smaller (2.5mm) Allen key supplied with the machine. Remove the fixed guide completely to free the old hammer. If still not possible to get rid of the old hammer, remove the four screws (**A, B, C, D**) and open the block H. (Two factory set locator pins **E & F** allow the plates to be re-positioned precisely again.)
- Remove the old hammer. Assemble the Block H back again.

Putting a new hammer (driver blade) :

- Put a drop of grease (tube of grease supplied with the machine) in the bottom hole of the wedge distributor (block H).
 - Insert a new hammer into block H with the hole of the hammer downwards.
 - Re-position the wedge distributor in its housing on the machine with the window towards the cartridge.
 - If the upper end of the hammer stays out of the block H, push it fully in with a piece of wood or moulding.
 - Leave the moulding in place (on block H) and put any of the top presser ends on the machine paying attention that the distance between the moulding and the top presser does not exceed **50 mm (2")**.
 - Turn on the air supply to the machine and without wedges make a simulation of assembly (press foot pedal and press the stapling button during the whole cycle.)
- The new hammer must have taken its position in the mechanism automatically.
- Turn off the air supply.
- Check with your finger that the block H does not stay out of the machine (higher than the work level) and tighten the locking screw of block H. No need to tighten too much.
 - Turn on the air supply ; the machine is ready to work again.

4) DISMOUNTING THE SLIDING TABLE

If you need to dismount the sliding table to clean dust etc accumulated underneath, remove the blocking handle **MB** of the sliding table (fig 1 p1) and clear the table while catching it by the two adjustment buttons **RI** (fig1 p1) of the fences inclination.

GENERAL ADVICE

If the hammer jammings are too frequent, it may be because of the use of not genuine Cassese cartridges.

The use of other wedges than genuine Cassese cartridges causes frequent hammer jammings and too fast mechanical ageing of your frame joiner.

**For any other technical problems,
do not hesitate to contact
your favourite supplier of Cassese products or
Cassese Factory (France), Int'al Department
on Phone +33.1.64.42.49.71 or 72
Fax +33.1.64.42.58.94 or +33.1.64.06.04.19**