



BENCHTOP CO2 INCUBATOR OPERATIONS MANUAL

FOR MODELS

6014

6016



PO Box 715
Marietta, OH 45750
800-648-3042 • 740-373-6809
Fax 740-374-3760
www.caronproducts.com
service@caronproducts.com

Dear Valued Customer:

Thank you for purchasing CARON Products & Services equipment. We appreciate your business and look forward to being your preferred supplier of controlled environment equipment products in the future.

At CARON, we are committed to continuous quality improvement. Our goal is to supply our customers with highly reliable equipment at a fair price. In order to openly monitor our performance, we would appreciate your feedback on our products and services.

If you have questions, or any suggestions for improvement based on the installation or operation of the equipment you have purchased, please contact our service department at service@caronproducts.com or 740-373-6809.

Thanks again for your business!

TABLE OF CONTENTS

Section 1 – Warranty	5
Section 2 – Equipment Overview.....	10
Section 3 – Installation	12
Unpacking	
Choosing a Location	
Preliminary Cleaning	
Installing the Port Stopper	
Installing the Shelves	
Leveling the Unit	
Connecting the Drain Line	
Connecting the Water Supply	
Connecting Electrical Power	
Section 4 – Optional Accessory Installation.....	18
Connecting Alarm Contacts (ALRM301)	
Installing the Carboy Water System (BOTL301)	
Connecting Communications or Analog Outputs (DLUX303)	
Installing Drain Water Pump (PUMP301)	
Installing the Side Mounted Recorders (RCDR311 & RCDR312)	
Installing the Stacking Kit (STCK301)	
Section 5 – Operation	24
Changing the Temperature Set-point	
Changing the Humidity Set-point	
Changing the CO2 Set-point	
Running a Decontamination cycle	
Section 6 – Optional Accessory Operation.....	29
Using the Carboy Water System (BOTL301)	
Operation of the Delux Controller System (DLUX303)	
Built in Gas Guard System (GASG301)	
Interior Electrical Outlet (OUTL301)	
Operation of the Front 6” Mounted Recorders (RCDR301 / RCDR302)	
Operation of the Front 10” Mounted Recorders (RCDR303 / RCDR304)	
Operation of the Side Mounted Recorders (RCDR305, RCDR306)	
Section 7 – Calibration	42
Calibrating the Temperature	

Calibrating the Humidity
Calibrating the CO2

Section 8 – Alarms	46
Alarm System Overview	
Changing Alarm Set-points	
Section 9 – Preventative Maintenance	47
Section 10 – Specifications	48
Section 11 – Electrical Schematics	49
Section 12 – Troubleshooting	52
Section 13 – Spare Replacement Parts	53
Section 14 – Advanced Users Section	55
Unlocking the Controllers	
Locking the Controllers	
Appendix A – Declaration of Conformity	56

SECTION 1- WARRANTY INFORMATION

CO² INCUBATOR LIMITED WARRANTY

Please review this section before requesting warranty service. At CARON, one of our primary goals is to provide customers with high levels of personal service and top quality products, delivered on time, backed by technical service and supported for the life of the product.

Before contacting us for warranty service, please be aware that there are repairs that are not covered under warranty.

WARRANTY DEFINED

Caron Products & Services, Inc. (herein after CARON) hereby warrants that equipment manufactured by CARON is free from defects in materials and workmanship when the equipment is used under normal operating conditions in accordance with the instructions provided by CARON.

COVERED:

- Parts and labor for a period of two (2) years from date of shipment.
- Any part found defective will be either repaired or replaced at CARON's discretion, free of charge, by CARON in Marietta, OH. Parts that are replaced will become the property of CARON.
- If CARON factory service personnel determine that the customer's unit requires further service, dependent of the model involved, CARON may, at its sole discretion, provide a service technician to correct the problem, or require the return of the equipment to the factory or authorized service depot.
- CARON will have the right to inspect the equipment and determine the repairs or replacement parts necessary. The customer will be notified, within a reasonable time after inspection, of any costs incurred that are not covered by this warranty prior to initiation of any such repairs.

NOT COVERED:

- Calibration of control parameters.
- Improper installation; including electrical service, gas and water supply tubing, gas supplies, room ventilation, unit leveling, facility structural inadequacies or ambient conditions that are out of specification.
- Cost of express shipment of equipment or parts.
- Any customer modifications of this equipment, or any repairs undertaken without the prior written consent of CARON, will render this limited warranty void.
- CARON is not responsible for consequential, incidental or special damages; whether shipping damage or damages that may occur during transfer to the customer's point of use. When the equipment is signed for at the customer's site, ownership is transferred to the customer. Any damage claims against the shipping company become the responsibility of the customer.
- Repairs necessary because of the equipment being used under other than normal operating conditions or for other than its intended use.
- Repair due to the customer's failure to follow normal maintenance instructions.
- Parts considered consumable; including: light bulbs, filters, gases, etc.
- Damage from use of improper water quality.
- Damage from chemicals or cleaning agents detrimental to equipment materials.

- Force Majeure or Acts of God.

This writing is a final and complete integration of the agreement between CARON and the customer. CARON makes no other warranties, express or implied, of merchantability, fitness for a particular purpose or otherwise, with respect to the goods sold under this agreement. This warranty cannot be altered unless CARON agrees to an alteration in writing and expressly stated herein shall be recognized to vary or modify this contract.

Ohio Law governs this warranty.

EQUIPMENT INTERNATIONAL LIMITED WARRANTY

Please review this section before requesting warranty service. At CARON, one of our primary goals is to provide customers with high levels of personal service and top quality products, delivered on time, backed by technical service and supported for the life of the product.

Before contacting your distributor for warranty service, please be aware that there are repairs that are not covered under warranty.

WARRANTY DEFINED

Caron Products & Services, Inc. (herein after CARON) hereby warrants that equipment manufactured by CARON is free from defects in materials and workmanship when the equipment is used under normal operating conditions in accordance with the instructions provided by CARON.

COVERED:

- Parts for a period of two (2) years from date of shipment.
- Any part found defective will be either repaired or replaced at CARON's or their authorized representative's discretion. Parts that are replaced will become the property of CARON.
- If CARON or their authorized representatives determine that the customer's unit requires further service, CARON or the representative may, at its sole discretion, provide a service technician to correct the problem, or require the return of the equipment to the an authorized service depot.
- CARON or their authorized representative will have the right to inspect the equipment and determine the repairs or replacement parts necessary. The customer will be notified, within a reasonable time after inspection, of any costs incurred that are not covered by this warranty prior to initiation of any such repairs.

NOT COVERED:

- Calibration of control parameters.
- Improper installation; including electrical service, gas and water supply tubing, gas supplies, room ventilation, unit leveling, facility structural inadequacies or ambient conditions that are out of specification.
- Cost of express shipment of equipment or parts.
- Any customer modifications of this equipment, or any repairs undertaken without the prior written consent of CARON, will render this limited warranty void.
- CARON and their representative are not responsible for consequential, incidental or special damages; whether shipping damage or damages that may occur during transfer to the customer's point of use. When the equipment is signed for at the customer's site, ownership is transferred to the customer. Any damage claims against the shipping company become the responsibility of the customer.
- Repairs necessary because of the equipment being used under other than normal operating conditions or for other than its intended use.
- Repair due to the customer's failure to follow normal maintenance instructions.
- Parts considered consumable; including: light bulbs, filters, gases, etc.
- Damage from use of improper water quality.
- Damage from chemicals or cleaning agents detrimental to equipment materials.
- Force Majeure or Acts of God.

This writing is a final and complete integration of the agreement between CARON and the customer. CARON makes no other warranties, express or implied, of merchantability, fitness for a particular purpose or otherwise, with respect to the goods sold under this agreement. This warranty cannot be altered unless CARON agrees to an alteration in writing and expressly stated herein shall be recognized to vary or modify this contract.

Ohio Law governs this warranty.

Caron Products & Services, Inc.
PO Box 715 · Marietta, OH 45750
740-373-6809

INTERNATIONAL SYMBOLS AND DEFINITIONS



Help



Information



Warning of hazardous area



Warning of dangerous electric voltage



Earth (ground) protective
conductor

WARNINGS



Local government may require proper disposal

SECTION 2 – EQUIPMENT OVERVIEW

Congratulations! You have just purchased the latest technology in incubators. Before using the equipment, familiarize yourself with key components of the product and thoroughly read this manual.

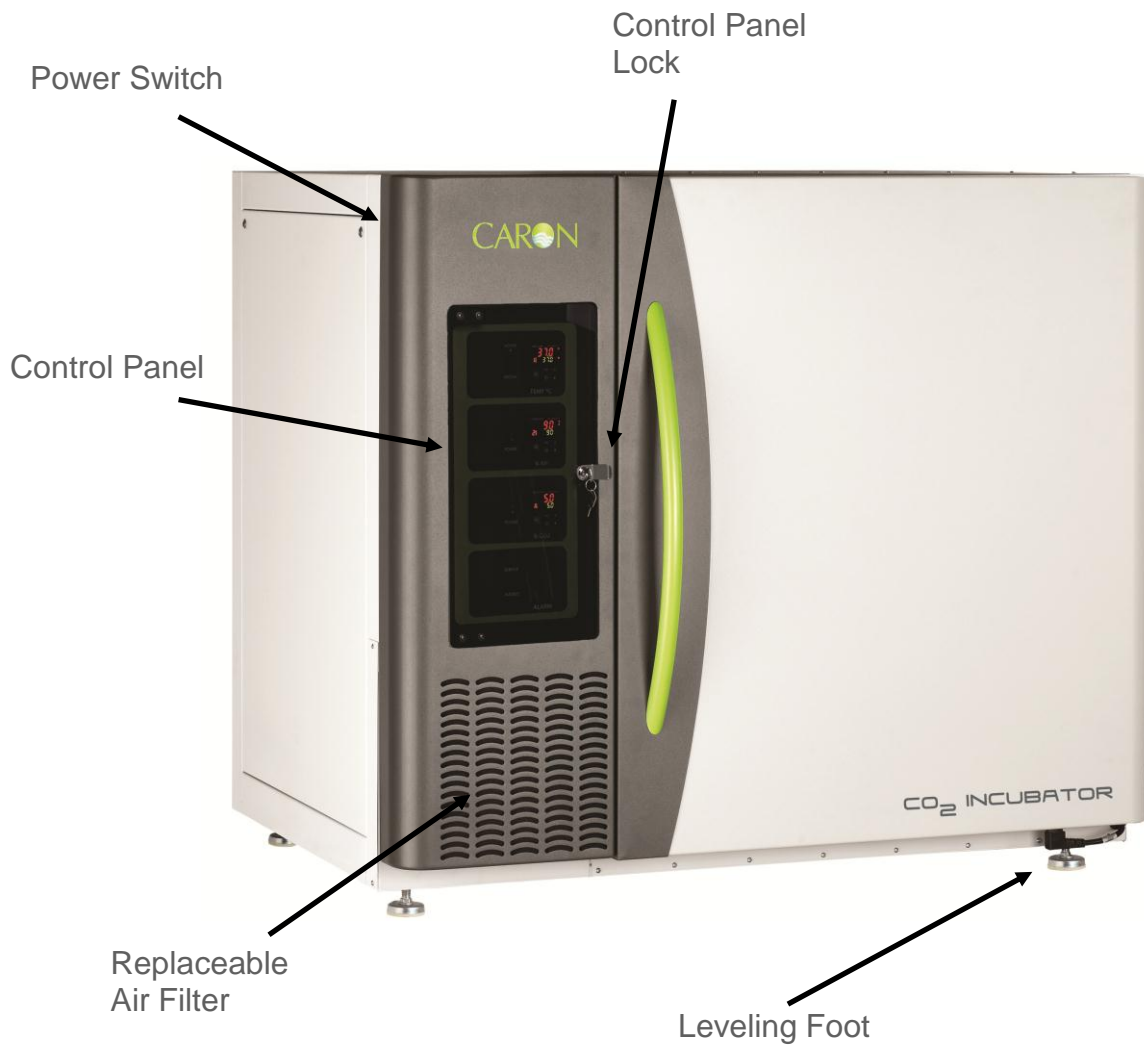

SECTION 2 – EQUIPMENT OVERVIEW -- CONTINUED



SECTION 3 -- INSTALLATION

Unpacking

Your new unit has been thoroughly packaged to avoid shipping damage. However, the unit should be fully inspected upon arrival before signing for receipt. If the package has visual damage, notes should be made on the freight bill and signed by the delivery company. In the event of concealed damage after the unit is uncrated, keep the carton and packaging material. Call the shipping company within 7 days of receipt, request inspection and retain a copy of the inspection report.

Caron provides full on-site installation services for all models. Our installation services guarantees the proper set-up and startup of all equipment. Please contact the Service Department at 740-373-6809 or service@caronproducts.com for details.

Choosing a Location



This product weighs in excess of 400 pounds. Ensure that sufficient resources are available to safely move the product.

To ensure proper operation, the unit must be located on a firm level surface, capable of supporting approximately 500 pounds (1000 pounds if the units are to be stacked). The unit should be located in an 18°C – 25°C ambient area and where there is no direct airflow from heating and cooling ducts as well as out of direct sunlight. Allow four inches of clearance on all sides of the product to allow for connections and airflow.

The unit requires a dedicated electrical connection. Power requirements vary depending upon the incubator model, see Connecting Electrical Power section.

Choose a location where these facilities are, or can be made available. If a water source, or a drain is not available, contact CARON customer service and ask about our CRY5102 product line or click this weblink for information on the product:

<http://www.caronproducts.com/65>

Preliminary Cleaning

Your new incubator was thoroughly cleaned prior to leaving the factory. It is recommended however, to disinfect all interior surfaces with a general purpose laboratory cleaning agent prior to using the product. After cleaning, dry all interior components with a sterile cloth as necessary.

Installing the Port Stoppers

The 6014 & 6016 have an access port built into the right side of the cabinet. The port is designed to allow customer access for equipment validation and for installation of other equipment inside the incubator. These ports should be sealed with the provided silicone stoppers to allow the incubator to function properly. Install the stopper provided in the port on the right side of the unit.

Installing the Shelves

Each new incubator includes three perforated stainless steel shelves. Each shelf requires two shelf channels for installation. The left and right shelf tracks are the same. Prior to installation, take time to consider what the size of the product being placed in the incubator will be and set the shelf spacing accordingly. Additional shelving can be purchased through CARON customer service if necessary.

To install the shelf channels insert the rear tab on the shelf channel into the rear pilaster on the side wall of the incubator. Then insert the front tab into the front pilaster. Push the entire shelf channel towards the rear of the unit and snap it down into place.



Each shelf is capable of supporting a uniformly distributed load of 50 pounds. The maximum incubator capacity is 200 pounds. An optional re-enforced floor is available for heavy loads.



Do not have multiple loaded shelves out simultaneously or the incubator may tip.

Stacking two Units

The 6014 & 6016 are designed to allow two units to be stacked. When units are stacked they must be bolted together for safety. A stacking adaptor kit, STCK301 with instructions is available through CARON customer service.



Failure to install the stacking adaptor kit can result in the top unit falling causing serious injury or death.

Leveling the Unit

Place a level on the middle shelf of the incubator. Adjust the cabinet leveling feet so the shelf is level. Units equipped with optional casters (CSTR101) can be leveled by adjusting the height of the lock nut on the caster. Adjust the feet or casters appropriately until the unit sits level left to right and front to back.

Connecting the Drain Line



When using a pressurized water source, failure to connect the unit to a drain could result in facility flooding.

The incubators control humidity by injecting water only as needed. This eliminates standing water which is a primary source of contamination and corrosion. There are several ways to take advantage of this feature. The simplest method is to connect the drain fitting and tubing supplied with the incubator to a local floor drain. During operation, any water that is not evaporated inside the cabinet will be sent to the cabinet drain to avoid standing water, minimizing the risk of contamination and corrosion.

The incubator drain connection is located in the bottom middle of the back of the incubator. A 3/8" NPT fitting and tubing are supplied in the unit parts kit. Thread the fitting into the drain connection and slide the tubing into the drain connection. Pull on the tubing after installation to make sure it is tight. Route the drain tubing to a local floor drain.



The drain line relies on gravity to remove water from the incubator. The drain line must remain below the incubator to drain properly. Kinks or elevations in the drain line above the cabinet drain will not allow the incubator to drain.

If a floor drain is not available, CARON offers a water recirculation system accessory (CRSY102) that acts as both a water supply and a drain for humidified incubators. This system continuously recycles any excess water not needed by the incubator, filters and conditions it, and reuses it to control humidity. www.caronproducts.com.

If neither a floor drain, nor a CRSY102 are available, another option is a carboy for a water source and a plug in the interior incubator drain. While this solution is not recommended due to the creation of standing water in the bottom of the incubator, it will allow the incubator to control humidity, with some limitations, while not requiring a drain. BOTL101 is a carboy accessory that can be purchased through CARON. A drain plug is provided in the shipping kit for each incubator.

Connecting the Water Supply

To ensure proper operation, distilled or deionized water is required as a supply on units that have humidity control. If these water sources are not available contact CARON customer service.



Use only distilled or deionized water with a resistivity between 50K Ω -CM and 1M Ω -CM and a pH of greater than 6.5. Using water outside this range will void your warranty.



Do not use water that contains chloramines. Chloramines can damage internal rubber gaskets resulting in leaks.

A water inlet fitting on the back of the unit and ¼” black tubing are provided to connect the water supply to the incubator. Connect an appropriate water supply to the fitting. Incoming line pressure should be regulated to not exceed 80 psi.

If a Condensate Recirculator water recycling system was purchased as a water supply, refer to its user’s manual for proper installation of the water supply.

Connecting a CO₂ supply



High concentrations of carbon dioxide can cause asphyxiation. The use of CO₂ monitors and alarms is recommended for areas where CO₂ can collect.



The CO₂ gas supply should be 99.5% pure and should not contain a siphon tube. Gas pressure to the unit must be regulated to 15-20PSI. Failure to do so could cause tubing to burst.

The CO₂ supply should be 99.5% and not have siphon tubes. CO₂ pressure should be regulated to 15-20 psi. CO₂ tank regulators can be purchased through CARON customer service. Once the cylinder regulator is installed, connect the outlet of the regulator to the hose barb fitting using the tubing and clamps provided. An inline HEPA filter is provided to remove any contaminants in the CO₂ gas supply. Check the connections closely for leaks.

If the unit is equipped with a built in gas guard system, there will be 2 gas inlets. Each of the inlets should be connected to an individual gas tank as described above.

Connecting Electrical Power



Connect each incubator to a grounded circuit. Failure to do so could result in electrical shock.

The unit requires a dedicated electrical outlet. See table below for model specific power required and connection.

Model #	Power Requirements	Plug Connection
-1	115V, 60Hz, 12A FLA	NEMA 5-15
-2	230V, 60Hz, 8A FLA	NEMA 6-15
-3	230V, 50Hz, 6A FLA	CEE 7/7

When the required electrical connection is available, plug the provided power cord into the unit and the electrical outlet.

SECTION 4 – ACCESSORY INSTALLATION

Connecting Alarm Contacts (ALRM301)

With the purchase of ALRM301, a set of terminals on the rear of the unit is provided to monitor temperature and humidity alarms.

With the alarm contacts, the terminals provided allow for a NO (normally open) output, a NC (normally closed) and COM (common) connection. In the event of an alarm condition or power failure, the NO contact will close, and the NC contact will open. Once the alarm is cleared, the contacts return to their normal conditions. Insert the appropriate wire into the terminal and tighten down the screw terminal on top of the connector.

Terminal Connection	Unit off	Normal	Alarm
N/O to C	Closed	Open	Closed
N/C to C	Open	Close	Open

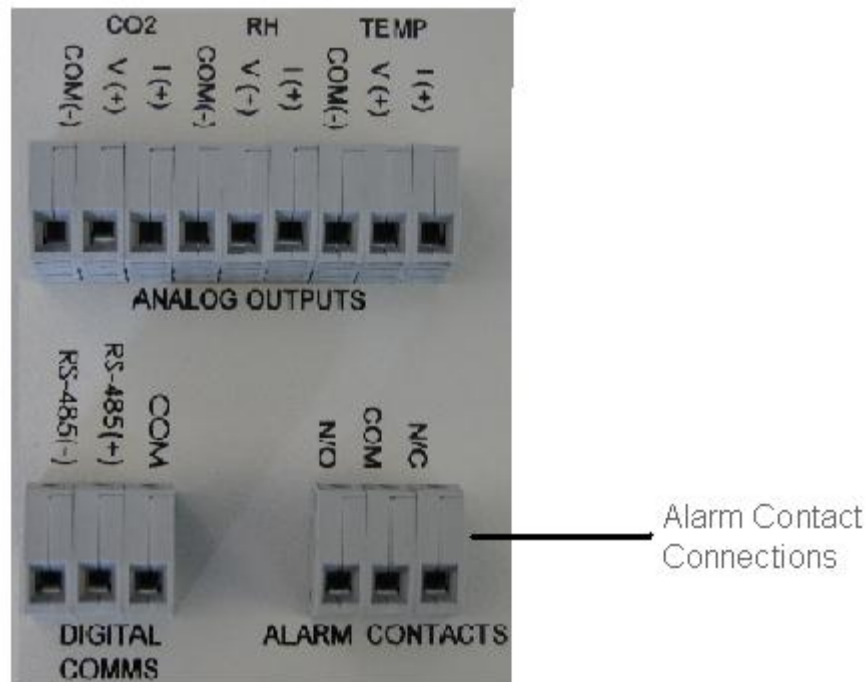

Installing Carboy Water System (BOTL301)

The optional 2.5 gallon carboy water system is preassembled and shipped inside the incubator. The four ¼” bolts required to mount the carboy to the unit will be mounted in the right hand side of the incubator. Remove the carboy assembly from inside the incubator and attach it to the incubator using the ¼” bolts.

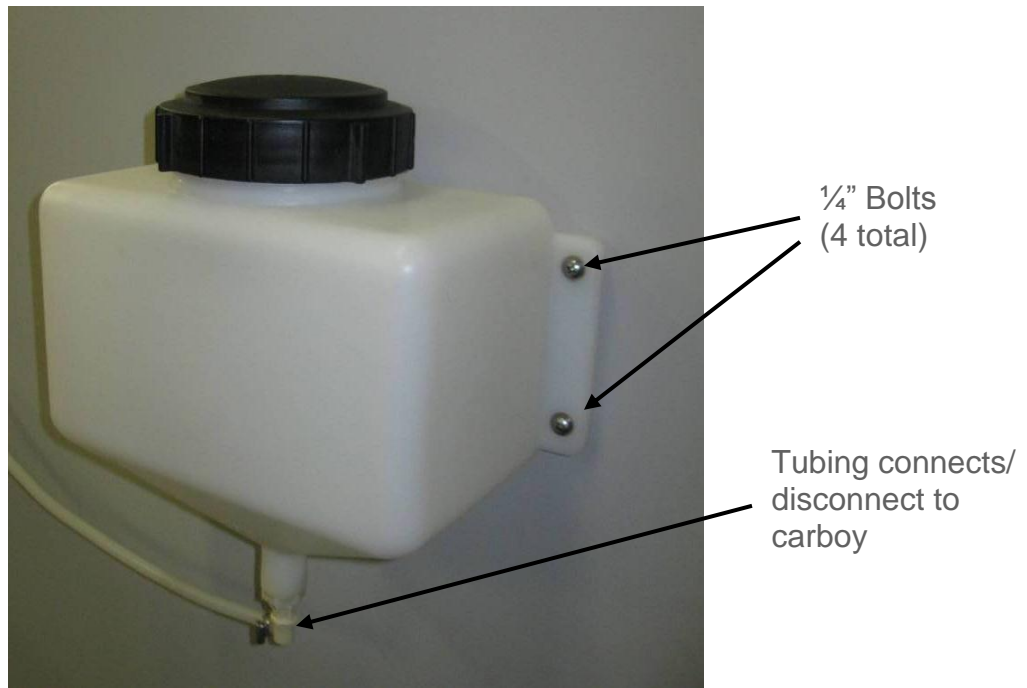

Attach the preassembled tubing provided with the carboy to the water inlet on the rear of the incubator. Fill the carboy with water as described in the “connecting a water supply” section of the manual.

Connecting Communications or Analog Outputs (DLUX303)

With the purchase of DLUX303, the controllers are upgraded with additional features such as RS485 communications, and analog outputs. A set of terminals are provided to connect to RS485 communications and analog outputs.

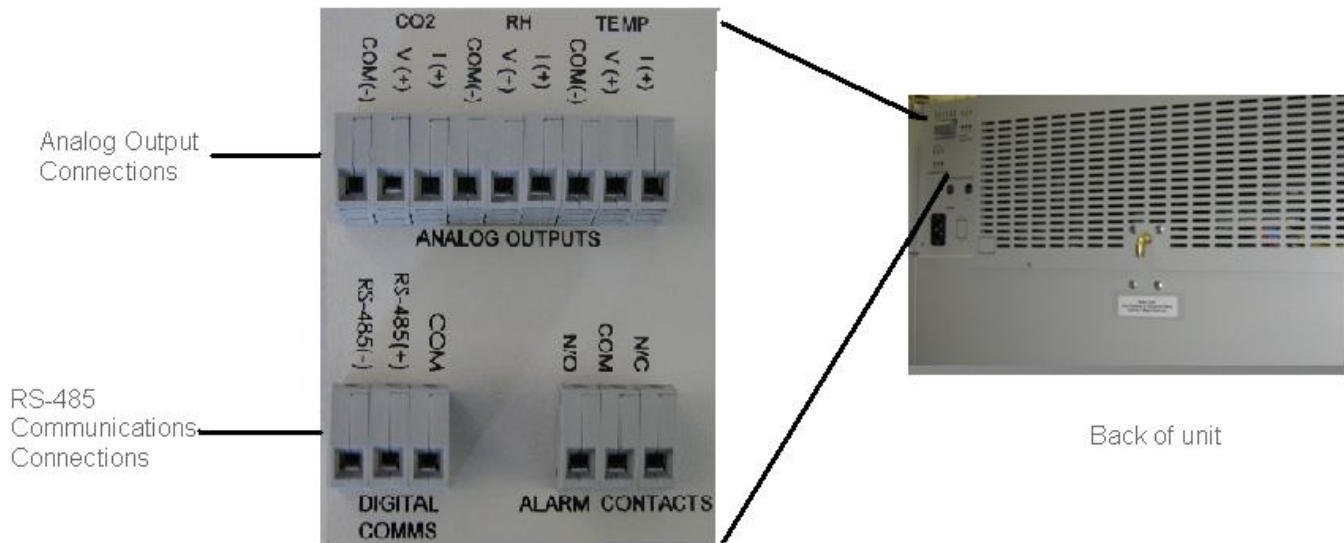

Analog Outputs

DLUX303 provide analog outputs as either milliamps (0-20mA, 4-20mA) or voltage (0-5V, 1-5V, 0-10V, 0-20V) signal output that represents each of the displayed temperature, humidity and CO₂ values. These options can be used for connection to in-house data acquisition, recorder, or alarm system.

Factory default settings are as follows:

Parameter	Analog Output	Corresponding Value
Temperature	0 – 5 V	0 – 100 °C
Humidity	0 – 5 V	0 – 100 %rh
CO ₂	0 – 5 V	0 – 100 %CO ₂

Connect shielded wires to the appropriate signal terminals: I(+) for current (mA) or V(+) for voltage (DC). For both current and voltage outputs, COM(-) is common terminal. The controller itself must be programmed for the voltage or current signal and corresponding scale (see Operations Section)

Communications

RS-485 communications are intended to communicate with a PC using ModBus RTU or Standard Bus. The maximum number of incubators connected to a single PC is limited to 247 controllers (Modbus) or 16 controllers (Standard Bus). Each incubator has 3 controllers.

Connect shielded wires to the RS-485 Communications terminal blocks. Communications wires should be shielded and routed away from power wires. Maximum distance of total wire is 2000 feet. When connecting multiple incubators, route wires in a daisy chain fashion. A termination resistor of 120 ohms may be placed across RS-485(-) and RS-485(+) of the last incubator in the daisy chain.

For PC's having an RS-232 serial port (9-pin D-Sub) connection, an RS-485 to RS-232 converter may be used. Recommended sources are B&B Electronics (P/N 485019TB) and CMC-Connecticut Micro Computer (ADA485L).

SFTW301 software is available from CARON to load onto a PC to monitor and record data. This data storage is not 21CFR Part 11 compliant.

Installing Drain Water Pump (PUMP301)

In applications where a floor drain is not available and a CARON water recycling system is not being used, a drain pump can be purchased to pump any excess condensate from the incubator to a local sink or drain. The pump is located near the middle of the back of the incubator. Connect the supplied tubing from the pump to the sink / drain. The tubing may be run vertically into a ceiling but should not exceed 15 feet height.

Installing Side Mounted Recorders (RCDR305 & RCDR306)

The recorder will arrive packaged inside the incubator. Carefully remove the recorder from its packaging. Mount the recorder by using the pre-installed recorder bracket. There are three factory drilled holes located on the right side of incubator as you face the front of incubator. Using the factory supplied screws, screw the recorder to the side of the incubator.

There are two cables that come out of the recorder. One is to power the recorder; the other is the temperature and/or humidity signals coming from the incubator. With power to the equipment turned off, plug the two connectors into their mating connector at the top of the incubator. Turn power to the incubator back on.

Standard factory set up for chart speed is 7 day operation. Refer to the Chart Recorder's User's Manual provided with the recorder to change the chart speed settings for various chart speeds.

Installing the Stacking Kit (STCK301)

Two incubators can be stacked using a stacking kit. The kit contains brackets and bolts to secure them together.



Each incubator weighs in excess of 400 pounds. Ensure that sufficient resources are available to safely lift and move the product.

Place the bottom incubator into its location. Using a lift or jack, place the other incubator on top. Bolt into place both brackets (back side, right & left) and secure the two together with 12 screws.



SECTION 5 – OPERATION

With the incubator properly installed and the appropriate utilities connected, the power switch on the upper left of the control bezel can be turned on. Within a few minutes, the temperature and humidity will begin to approach set-points. Allow the unit to stabilize for 12 hours before use or prior to making any calibration adjustments.

Changing the Temperature Set-point

If an alternative temperature set-point is required, the following steps can be taken:



Press the up arrow to increase the temperature set-point by 0.1°C. Press the down arrow to decrease the temperature set-point by 0.1°C. Pressing and holding either button will cause the set-point to scroll rapidly in either direction.

Changing the Humidity Set-point

If an alternative humidity set-point is required, the following steps can be taken:



Press the up arrow to increase the humidity set-point by 1% RH. Press the down arrow to decrease the humidity set-point by 1% RH. Pressing and holding either button will cause the set-point to scroll rapidly in either direction.

If humidity is not required in the incubator, the RH system can be disabled by turning off the Enable Humidity switch. This will disable the entire RH system including the controller. The system can be turned back on at anytime.

At humidity levels above 80%, condensation forming on the door is normal.

Changing the CO₂ Set-point

If an alternative CO₂ set-point is required, the following steps can be taken:

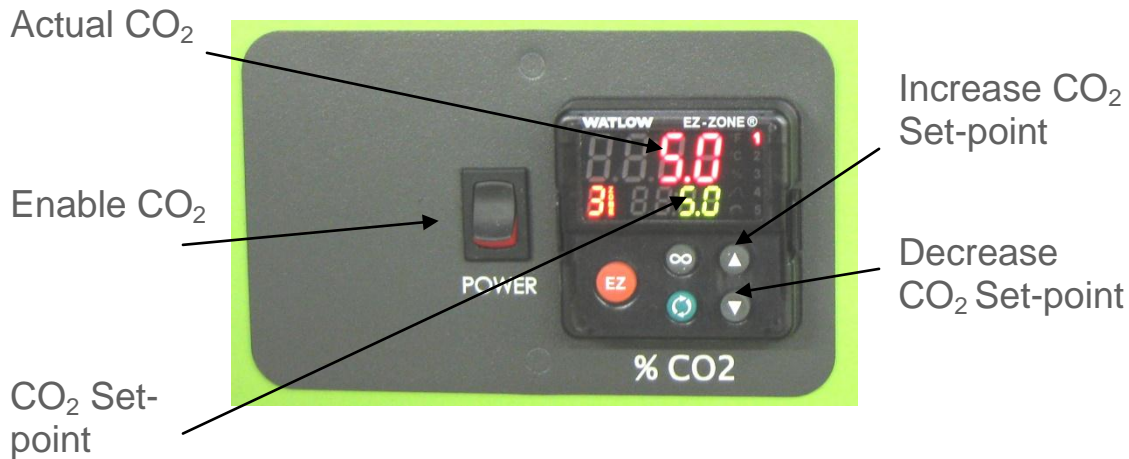

Press the up arrow to increase the CO₂ set-point by 0.1% CO₂. Press the down arrow to decrease the CO₂ set-point by 0.1% CO₂. Pressing and holding either button will cause the set-point to scroll rapidly in either direction.

If CO₂ is not required in the incubator, the CO₂ system can be disabled by turning off the Enable CO₂ switch. This will disable the entire CO₂ system including the controller. The system can be turned back on at anytime.

Using the Decontamination Cycle

The incubator is equipped with an automatic moist heat decontamination cycle. The purpose of the cycle is to eliminate common microbial contamination in your incubator and extend the time between manual cleaning cycles. CARON's incubator is equipped with a controlled humidity system that eliminates standing water which is the primary source of contamination. The decontamination cycle is intended to be used as a reactive system to eliminate contamination. It is not necessary to run the cycle at a fixed time interval.

Before initiating a decontamination cycle, the following steps must be completed:

- 1) Remove all samples, products, equipment, etc ... from the incubator.
- 2) Power down the incubator.
- 3) If the unit is equipped with an inner door kit, remove the inner doors and lay them on the incubator shelving during the decontamination cycle.
- 4) Locate the removable sensor access plate in the right wall of the incubator. Remove the plate by sliding the fasteners down.
- 5) With power off, remove the infrared CO2 sensor by unscrewing the connector on the rear of the CO2 sensor. The sensor unscrews where the orange cable meets the gray sensor housing.



Failure to remove the sensor will result in damage to the sensor and will not be covered by warranty.

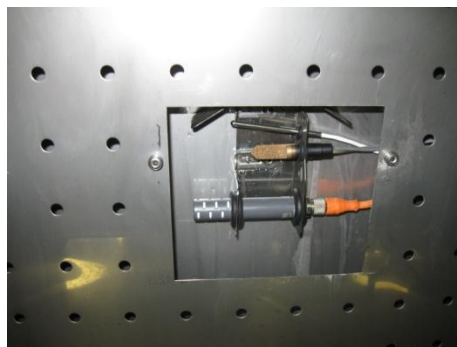
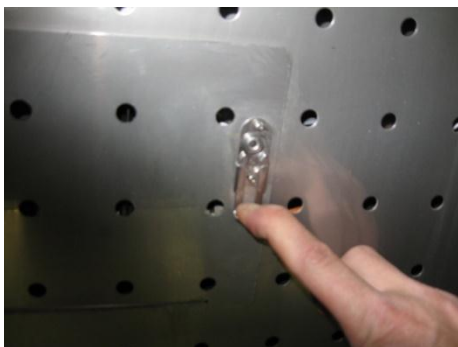

- 6) Insert the orange cable into the grommet where the sensor was removed so that it is easily accessed when the sensor is replaced following the decon cycle.
- 7) Replace the CO2 sensor plate and turn the incubator power switch back on.
- 8) The CO2 controller will not read the correct value with the sensor unplugged. Turn off the power switch to the individual CO2 controller on the control panel.

- 9) Press the decon cycle switch located on the temperature controller panel. The yellow light will indicate the cycle is active.
- 10) The infrared CO2 sensor can be disinfected using isopropanol. Spray the cleaner on a soft clean cloth and wipe the sensor.



Do not immerse the sensor in any type of cleaner as damage to the sensor may occur.

With the decontamination cycle now active, the following automatic steps will occur:

- 1) The unit will heat the incubator to approximately 90°C over a 2 hour period.
- 2) At the end of the 2 hour period, moisture will be injected raising the humidity level to create a high temperature, high moisture environment. This level will be held for 9 hours. Some level of condensation forming on the door is common during the cycle.



The decon cycle will heat the incubator interior surfaces to approximately 90C. Do not open the exterior door during the cycle, as contact with interior surfaces may result in burns. If the outer door is opening during the decon cycle, an audible warning alarm will occur.

- 3) After the moist heat cycle step, an external pump injects HEPA filtered dry air into the incubator. This allows the incubator to quickly cool down and remove moisture. This cool down / dehumidification process takes 3 hours.
- 4) After the cabinet is cooled down and the moisture removed, the temperature and humidity will return to their previous set-points. The decon cycle indicator light will go off and the cycle is complete.

With the decontamination cycle now complete the following steps can be completed to return the incubator to service.

- 1) Power off the incubator.
- 2) With power removed, plug the disinfected Infrared CO2 sensor into the position it was initially removed from in the right wall.
- 3) Turn the incubator back on. Turn the CO2 controller power back on. Allow the incubator to stabilize at selected temperature, humidity, and CO2 setpoints.

SECTION 6 – ACCESSORY OPERATION

Using the Carboy Water System (BOTL301)

To fill the carboy while attached to the incubator, unscrew the cap. Fill carboy with distilled or deionized water (see Connecting the Water Supply section for details). The carboy holds 2.5 liters.

If the carboy must be removed in order to fill it up, first disconnect the tubing between the carboy and incubator by pressing the metal lever at the tubing connects / disconnects at the bottom of the carboy. Then unscrew the four mounting screws and remove the carboy. After re-attaching the carboy, connect the tubing by simply pressing the plastic fittings into each other.

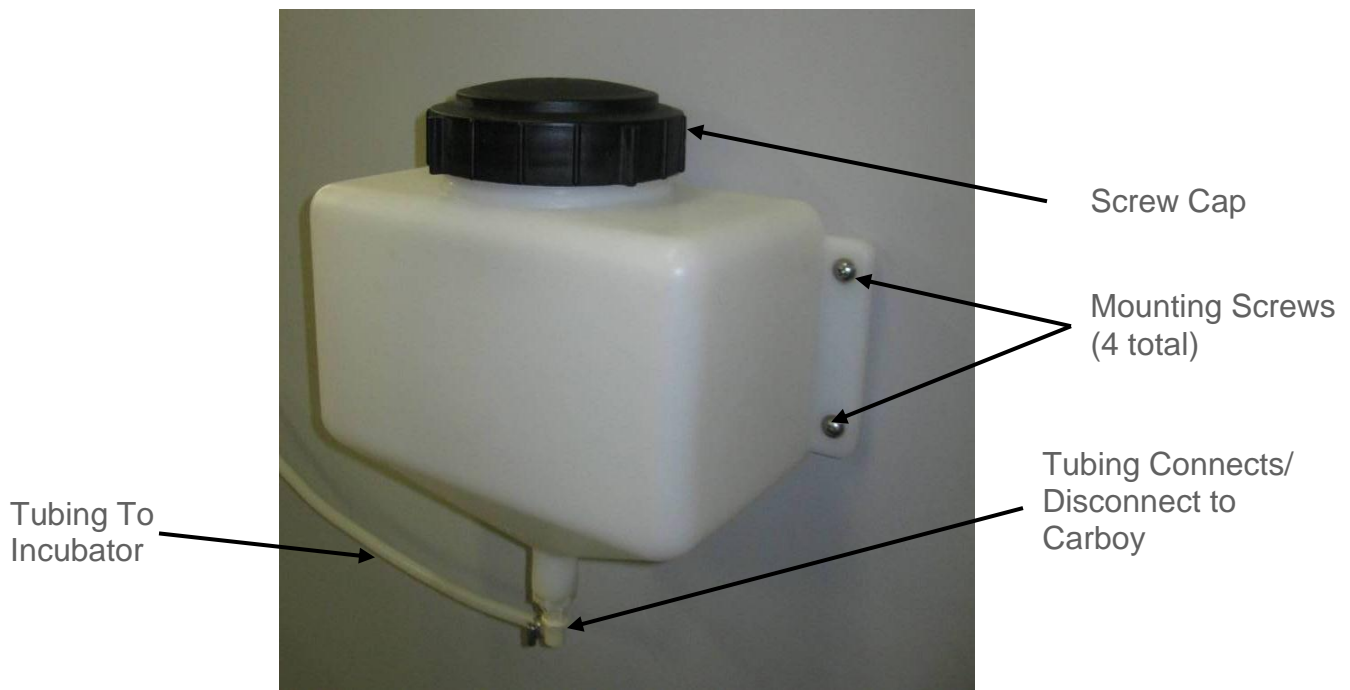

Operation of the Delux Controller System (DLUX303)

The incubators can be purchased with upgraded controllers. The controllers have additional features of RS485 communications, analog outputs, and ramp & soak.

RS485 Communications:

The RS485 communications signals can be daisy chained from product to product and connected to a PC. Each controller on the network must be programmed with a unique address. Factory defaults for the controllers are addresses 1 for temperature, 2 for humidity, and 3 for CO2. If multiple incubators are being connected, each controller will have to be assigned a unique address. As an example, a second incubator would need to be assigned address 4 for temperature, 5 for humidity, and 6 for CO2. To assign new addresses to controllers, the controllers must be unlocked. Refer to Section 13, Unlocking the Controllers.

Once the controllers are unlocked on each controller, follow these steps to set a unique address for each controller:

- 1) Press and hold the up and down key simultaneously for six seconds.
- 2) The upper display will read Ai and the lower will read SET
- 3) Press the up key until the upper display reads CoM
- 4) Press the advance key until PCoL appears
- 5) Set the protocol to either Modbus (Mod) or Standard Bus (Std)
- 6) Press the advance key until Ad.M (Modbus) or Ad.S (Standard) appears
- 7) Press up/down to increase/decrease the address number
- 8) *Press the advance key until bAUd appears
- 9) *Press the up/down arrow keys to set the baud rate (38.4K is default)
- 10) *Press the advance key until Par appears
- 11) *Press the up/down arrow keys to set the Parity ('none' is default)
- 12) *Press the advance key until M.hL appears
- 13) *Press the up/down arrow keys to set the Word Order ('Lohi' is default)
- 14) Press infinity to exit to the main menu

*When using ModBus, other parameters such as Baud Rate, Parity, and Word Order must be set. Standard Bus only requires a unique address be set.

Once all addresses are entered refer to Section 13 to relock the controllers.

Analog Outputs:

With DLUX303 controllers, there is an analog output signal for temperature and humidity which represents the actual incubator values. This allows the incubator to be connected to an in-house data acquisition or alarm system.

The analog signal outputs are selectable as either voltage DC or milliamp. In both cases, the output is scalable from 0.0 to 20.0. Common settings are 0-1V, 0-5V, 1-5V, 0-10V, 0-20mA, and 4-20mA. The factory default settings are 0-5V.

For each selected output range, a temperature and humidity value must correspond to the high and low range. This range should be large enough to encompass the entire incubator possible values and small enough to provide adequate resolution. The analog outputs can be calibrated by placing an offset into the controller. This offset affects only the analog outputs and not the controller displayed value. To change the controller displayed value, see the calibration section in the manual.

To change the factory defaults of the controllers, the controllers must be unlocked. Refer to Section 14, Unlocking the Controllers.

1. Pressing the up and down keys simultaneously for 6 seconds.
2. Press the up key until otPt is displayed
3. Press the advance key until the upper display reads 1
4. Press the up button until 3 is displayed
5. Press the advance button to scroll through the parameters; use the up and down arrow buttons to change the parameters. Factory default parameters are listed below

Parameter Description	Display	Value
Type	o.tY	Volt
Function	Fn	rMt
Retransmit Source	r.Sr	Ai
Scale Low	S.Lo	0.00
Scale High	S.hi	5.00
Range Low	r.Lo	0.0
Range High	r.hi	100.0
Calibration Offset	o.CA	0.0

For a DC volt output, set the Type to “Volt”

For a mA output, set the Type to “MA”

Set the Scale Low value to correspond with the minimum value of the process output in electrical units. For 0-5V, set to 0. For 1-5V, set to 1. For 4-20mA, set to 4.

Set the Scale High value to correspond with the maximum value of the process output in electrical units. For 0-5V, set to 5. For 1-5V, set to 5. For 4-20mA, set to 20.

Set the Range Low value to the minimum temperature (or humidity or CO₂) that will correspond with the Scale Low value (default is 0.0).

Set the Range High value to the maximum temperature (or humidity or CO₂) that will correspond with the Scale High value (default is 100.0).

6. If an offset (or calibration) is needed, adjust the o.CA parameter accordingly
7. Press and hold the infinity button for 2 seconds to exit to home page

Once all changes are made refer to Section 14 to relock the controllers.

GASG301 Built In Gas Guard System

An optional built in gas guard system is available to allow two tanks of CO₂ to be connected to an incubator requiring approximately 15 psig of gas pressure. The unit is designed to automatically switch from the primary tank to the secondary tank when low gas pressure of approximately 10 psig is detected on the primary tank. This allows for a continuous supply of CO₂ to an incubator after the primary tank is empty. In addition, the user is notified of a tank empty scenario via an audible and visual alarm.



The CO₂ gas supply should be 99.5% pure and should not contain a siphon tube. Gas pressure to the unit must be regulated to less than 30 psig. Failure to do so could cause tubing to burst.

The CO₂ gas supplies must be equipped with two stage regulators to ensure that the incoming gas to the unit is regulated to appropriate levels. The high pressure stage should have a 0-2000 psig range, and the low pressure gauge should adjust from 0-30 psig. When connecting the gas supplies, adjust each tank output to 20-25 psig. If the

appropriate regulators are not available, contact CARON customer service to purchase them.

Once the cylinder regulators are installed and adjusted on each tank, connect the outlet of the regulator on Tank 1 to the hose barb fitting labeled Tank 1 on the back of the unit. Repeat the process for Tank 2. Turn on the regulated gas supplies and check the connections closely for leaks.

The power switch is used to turn on/off the operation of the product. If power is off, the unit will allow gas to flow through Tank 1 if required by the incubator.

The factory default “master tank” is Tank 1. When the appropriate gas pressure is supplied to both tanks, the master tank will always be used as the gas source. The unit will swap from the master tank to the alternative tank whenever a low gas pressure condition is detected.

The alarm switch is used to disable the audible alarm when a low gas condition is detected. The audible alarm can be silenced while a new tank is installed by selecting the silence position. Once a low gas pressure condition is resolved, it is recommended that the alarm switch be returned to audible to ensure audible notification of future low gas pressure conditions. As a reminder, the Tank 1 and Tank 2 alarm lights will be illuminated for as long as a low pressure condition is present on the respective tank.

Interior Electrical Outlet (OUTL301)

An optional interior electrical outlet is available to supply power to small interior appliances such as shakers or stirrers. The outlet is GFI protected. The interior outlet is fused at 2.0 Amps. It is not intended to power high current draw devices.

Operation of Front Mounted 6” Recorders (RCDR301, RCDR302)

Built in 6” ink pen temperature and or humidity recorders can be purchased with CARON incubators. The recorders are shipped installed on the outer door of the incubator from the factory and require no installation.

Changing the chart paper:

Press and hold the “change chart” button on the recorder (#3) for approximately one second until the pen begins to move to the left of the chart and then release the button. Wait until the pen has completely moved off of the chart. To remove the chart paper, unscrew (counter-clockwise) the chart “hub” knob at the center of the chart. Remove the old chart paper and position the new one so that the correct line coincides with the time line groove on the chart plate.

Re-attach the chart “hub” knob and fasten securely against the chart. Press and hold the “change chart” button (#3) again for approximately one second until the pen begins to move back onto the chart and then release the button. Check to make sure that the pen is marking on the chart paper. If it is not, then carefully adjust the pen arm to establish contact with the paper.

Chart recorder marking system:

This type of pen consists of a self contained ink reservoir with a porous plastic stylus which is snapped around the outer edge of the metal pen arm. A pen cap is provided to extend the life of the ink pen during shipping or when the recording unit is not in service. To remove the pen cap, gently lift the pen arm away from the chart paper. Remove the black plastic pen cap to expose the fiber tip of the ink pen and gently place the pen back onto the chart paper. Do not let the pen arm "snap" back onto the chart paper. This will flatten the fiber tip of the pen and will no longer give you a fine line marking on the chart paper. Place the pen cap in a safe place for future use. If the stylus does not touch the chart, adjustment can be made by slightly bending the metal pen arm in the center towards the chart paper. Do not use more pressure than is necessary to create a fine line marking on the chart paper. As the pen ink supply runs out, the pen color will become lighter. This indicates that the pen should be replaced.

Replacement of the Pen:

Recorders that are equipped with fiber tipped cartridge pens will have a cartridge that is color coded "red" to designate pen number one and an optional cartridge that is color coded "blue" to designate pen number two. The pen cartridge is securely fastened to the metal pen arm using a special "U" clip tab. For ease of replacement, it is suggested that

the two screws that hold the pen arm be loosened and the pen cartridge and metal pen arm be removed as an assembly. Unsnap the plastic "U" clip tab of the pen cartridge from the metal pen arm, remove and discard the old pen cartridge. Replace the new cartridge by opening the hinge and snapping it securely around the metal pen arm. Refer to the image below:

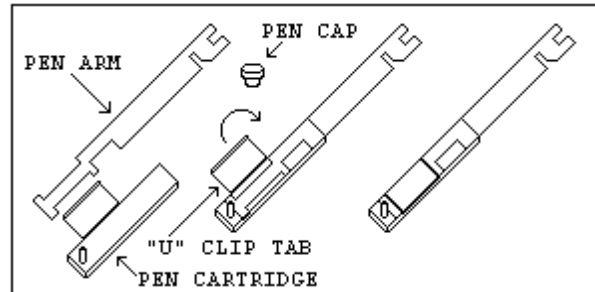

Pen Arm Calibration:

To check and/or adjust the recording pen(s) calibration to the outer most temperature graduation of the chart, press and hold the "change chart" button (#3) until the pen begins to move off of the chart. Once the pen(s) has moved off of the chart, again press and hold the "change chart" button (#3) until the pen begins to move back onto the chart. The pen should briefly stop at the outer most temperature graduation of the chart before continuing onto the chart to begin recording. If the pen does not stop exactly at this location on the chart, it can be adjusted or "calibrated" by using the left (#1) or right (#2) arrow buttons.

When the pen moves back onto the chart and briefly stops, you will have approximately five seconds in which to adjust the pen's position using the left and right arrow buttons of Figure 3.

On multiple pen recorders, each pen will move (one at-a-time) onto the chart briefly stopping at the outer most temperature graduation of the chart at which time the pen's position can be adjusted by using the left (#1) or right (#2) arrow buttons. When the time to adjust the position of the first pen has expired, the second pen will move onto the chart briefly stopping at the outer most temperature graduation of the chart at which time the second pen's position may be adjusted.

Each time the chart paper or fiber tip pen cartridge is changed, you should make sure that each pen stops at the outer most temperature graduation of the chart paper. Otherwise, this pen offset will cause the unit to record an incorrect temperature on the chart.

Recorder Calibration:

If a calibration adjustment is required for a single pen recorder, use the left (#1) and right (#2) arrow push buttons on the recorder to calibrate (or move) the pen's position on the chart to correspond to the temperature of the solution. The arrow buttons must be held for approximately five seconds before the pen will begin to move.

For two pen recorders, you must first select the pen that you wish to calibrate. This is done by pressing the left (#1) arrow button to select the red pen or the right (#2) arrow button to select the blue pen. The arrow button must be held down until the green LED light goes out. After the green LED light goes out, follow the instructions in step #3 above.

Battery Backup:

The green LED light remains a constant green color indicating that both the battery and the main power to the unit are good. Refer to Figure 5 for the location of the green LED indicating light. If the AC power were to fail or the battery becomes weak, then the green LED light will begin "flashing" indicating that either you have lost the main power to the unit or it is time to replace the battery. Having a 9 volt DC battery back-up in place, will allow the recorder to continue to function normally for approximately 24 hours in the event of a power failure.

Operation of Front Mounted 10" Recorders (RCDR303, RCDR304)

Built in 10" thermal pen recorders can be purchased with CARON incubators. The recorders are shipped installed on the outer door of the incubator from the factory and require no further installation. Unlike ink pen recorders, the thermal recorders draw their own chart and control lines.

The 10" recorders have been setup at the factory in the following configuration: 7 Day / 24 Hour / Temperature 0-100°C / Humidity 0-100% (for dual input recorders). If this is not the ideal configuration for an application, the recorder may be reconfigured using the following process:

Configuring the recorder:

In order to configure the recorder, you will need to enter the set-up mode of the recorder. To enter the set-up mode of the recorder, press and hold the Change Chart button (#3) until the thermal pen arm begins to move off scale and then release the button.

Note: The green LED light will flash fast while the thermal pen arm is moving off scale.

Wait until the thermal pen arm has moved completely off scale and stops (the green LED light will stop flashing and will be steady On). Unscrew (counter clockwise) the chart "hub" knob at the center of the chart and remove the recording chart paper. Gently lift the thermal pen arm just enough to be able to slide the paper out from beneath it. Remove the recording chart paper and place the Setup Chart onto the recorder. This chart contains the configuration categories of the recorder (Probe Input, Inner Chart Temperature, Outer Chart Temperature, Temperature Scale, Chart Rotation Speed, Input Filtering, Optional Relay Contacts and Date/Time for internal clock).

Next, press and hold either button #1 or #2 until the green LED light goes out and release the button. If this step is successfully completed, the pen arm will move to the outermost graduation ring of the Setup Chart. Use the Left (#1) or Right (#2) arrow buttons to adjust the center of the thermal pen to be on this outermost graduation ring.

Position the Setup Chart so that the tip of the thermal pen is in the center of the Start circle. Tighten the chart hub knob to secure the chart in place. Next, press and release the Change Chart button to begin. The chart will rotate to the first category (Input #1). Use the Left and Right arrow buttons to move the thermal pen arm to the desired option of each category. Press and release the Change Chart button to accept the selection and advance to the next category. You must press and release the Change Chart button when you have finished configuring the last category in order to save all of the changes that have been made to the recorder's configuration. The thermal pen arm will

move off of the chart allowing you to place the recording chart paper onto the recorder. Press and release the Change Chart button to begin recording.

Changing the Chart Paper:

Press and hold the Change Chart button (#3) for approximately one (1) second until the pen begins to move off scale and then release the button.

Note: The green LED light will flash fast while the thermal pen arm is moving off scale.

Wait until the thermal pen arm has moved completely off scale and stops (the green LED light will stop flashing and will be steady On). To remove the chart paper, unscrew (counter clockwise) the chart "hub" knob at the center of the chart. Gently lift the thermal pen arm just enough to be able to slide the paper out from beneath it. Remove the old recording chart paper and position a new one.

Re-attach the chart "hub" knob and screw securely (by hand) against the chart. Press and hold the Change Chart button (#3) again for approximately one (1) second and the thermal pen arm will move back onto the chart and begin recording.

Green Light LED Status:

The green LED light (located just below the three button membrane switch) is used to show the recorder's status:

- 1.) LED on steady (not flashing) and input(s) recording within chart range, indicates unit is recording normally.
- 2.) LED on steady (not flashing) and pen arm above outermost graduation and not moving, indicates recorder is in Change Chart mode. Press and release Change Chart button to return to normal recording mode.
- 3.) LED flashing rapidly and one or both inputs recording at outermost or innermost graduation indicates a sensor break. Check or replace sensor(s). If sensor(s) are ok, make sure process temperature is within configured range of recorder.
- 4.) LED flashing slowly (.8 seconds ON / .8 seconds OFF) indicates recorder is in Set-Up mode. Refer to section CONFIGURING THE RECORDER.
- 5.) LED is Off indicates that there is no power to the recorder. Check A/C power to the recorder.

Recorder Calibration:

If calibration is required for single input recorders, use the Left (#1) and Right (#2) arrow buttons on the recorder to calibrate the temperature being recorded on the chart to correspond to the temperature of the solution. The arrow buttons must be held for approximately eight (8) seconds before the pen begins to move.

If calibration is required for dual input recorders, you must first select the input that you wish to calibrate. This is done by pressing and holding the Left (#1) arrow button to select Input #1 or the Right (#2) arrow button to select Input #2. The arrow button must be held down until the green LED light turns off, after which follow the instructions in single input instructions above.

Maximizing Pen Life:

In order to maximize the amount of life expected out of the thermal pen tip, follow these simple rules:

- 1) Never let the thermal pen tip ride on the chart plate when the chart paper is not present. This will damage the protective coating of the heating element.
- 2) Never use chart paper that is creased or that has been folded.
- 3) Periodically clean the thermal pen tip with a cotton swab dipped in alcohol. Clean more often when operating the recorder in a dusty environment.
- 4) Always keep the door closed while the unit is recording.
- 5) Never lift the pen arm more than is necessary to remove and replace the chart paper. Excessive lifting may cause a decrease in the pen tip pressure and cause light printing.

Operation of Side Mounted Recorders (RCDR305, RCDR306)

Side mounted Honeywell DR 4300 General Purpose Circular Chart Recorders are also available with CARON incubators. This chart recorder uses reliable microprocessor operation to generate dependable pen drawn analog traces on preprinted 10-inch (250 mm) charts. The two-pen model accepts inputs from a temperature sensor and a humidity sensor. The single-pen model records temperature only. The recorders are housed in a molded case with a glass windowed, gray gasketed door which protects internal components while allowing easy access to the chart.

Routine Maintenance:

The recorder does not require any periodic maintenance. However, the chart and ink cartridges will have to be replaced as required.

Replacing the Ink Cartridge:

Refer to Figure 8 in the Honeywell manual: Replacing the Ink Cartridge and Chart.

1. Remove power from recorder. Push in the button on the door and swing the door open.
2. Pull up on the pen lifter to raise the pens from the chart plate. NOTE: DO NOT LIFT THE PENS DIRECTLY

CAUTION: Be careful not to move the pen arm while removing and installing the ink cartridge. The longer pen arm is pen #1

3. Unclip and remove the purple (Pen #1) or red (Pen #2) ink cartridge for the pen arm.
4. Remove the protective cap from the pen tip on the new cartridge and open its clip.
5. Slide the new cartridge onto the pen arm so that its tip fits into the notch at the end of the pen arm and close the clip to secure the cartridge to the pen arm.
6. Push down the pen lifter to return the pen tip to the chart.
7. Close the door and apply power.

Replacing the chart:

Refer to Figure 8 in the Honeywell manual: Replacing the Ink Cartridge and Chart.

1. Remove power from recorder. Push in the button on the door and swing the door open.
2. Pull up on the pen lifter to raise the pens from the chart plate. NOTE: DO NOT LIFT THE PENS DIRECTLY

3. Lift the chart from the hub and locating pin and slide it from under the pens to remove it from the chart plate.
4. Slip the new chart under the pen lifter, pens and time index; and press the chart into place over the chart hub and locating pin.
5. Grasp the chart hub and locating pin and turn the chart until the desired time line on the chart is aligned with the time index on the chart plate and Pen #1. Push down the lifter to return the pens to the chart.
6. Close the door and apply power.

SECTION 7 – CALIBRATION

The temperature and humidity systems can all be calibrated as necessary. CARON recommends an annual calibration check of each system. Before making a calibration adjustment, allow the cabinet to stabilize a minimum of 12 hours from a power off condition. If the unit has been in operation, allow a minimum of 3 hours of stable operation at all set-points. If you do not have the appropriate reference instruments to perform calibration, contact CARON's service department for on-site calibration at service@caronproducts.com. Caron also provides validation services which ensures that the unit is functioning properly according to IQ, OQ and PQ protocols which satisfy FDA guidelines for qualification verification of equipment.



Be sure that all reference instruments are calibrated to an appropriate standard.

Calibrating the Temperature

If temperature calibration is needed, the following steps can be taken:

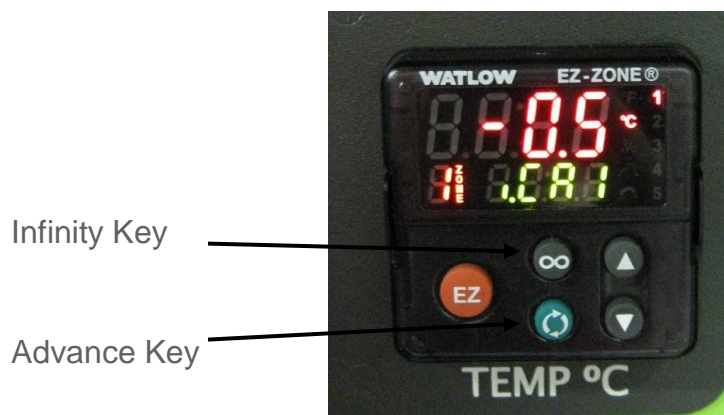

Locate the reference instrument's temperature sensor in close proximity to the cabinet's geometric center. Be sure that the stabilization times described earlier have been satisfied prior to performing calibration. Press the advance key until the green display reads i.CAL (calibrate). Pressing the UP arrow will increase the Temperature calibration offset by 0.1°C. Pressing the down arrow will decrease the Temperature calibration offset by 0.1°C. Pressing and holding either button will rapidly scroll the calibration offset. When finished, press the infinity key to return to the main menu.

Temperature calibration example

If the incubator temperature display reads 40.0°C and the calibrated independent sensor shows 40.3°C, set the i.CAL offset value to 0.3°C. If the calibrated independent sensor shows 39.6°C, then the entered offset should be negative. In this example the required offset to i.CAL would be -0.4°C.

Calibrating the Humidity

If humidity calibration is needed, the following steps can be taken:

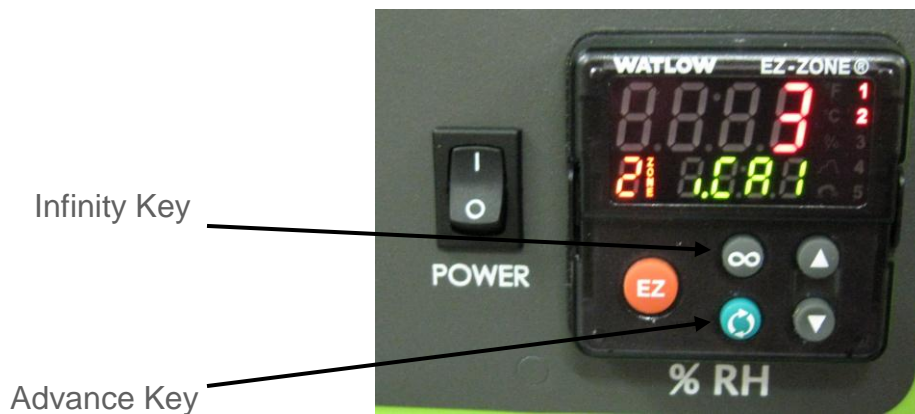

Locate the reference instrument's temperature sensor in close proximity to the cabinet's geometric center. Be sure that the stabilization times described earlier have been satisfied prior to performing this calibration. Press the advance key until the green display reads i.CAL (calibrate). Pressing the UP arrow will increase the Humidity calibration offset by 1%. Pressing the down arrow will decrease the Humidity calibration offset by 1%. Pressing and holding either button will rapidly scroll the calibration offset. When finished, press the infinity key to return to the main menu.

Humidity calibration example

If the incubator temperature display reads 80% and the calibrated independent sensor shows 83%, set the i.CAL offset value to 3.0%. If the calibrated independent sensor shows 74°C, then the entered offset should be negative. In this example the required offset to i.CAL would be -6.0%.

Calibrating Optional Chart Recorders

For calibrating the optional front and side mounted chart recorders, refer section 6 (Optional Accessory Operation)

Calibrating the CO₂

If CO₂ set-point calibration is required, the following steps can be followed:



Locate the reference instrument's CO₂ sensor in close proximity to the cabinet's geometric center or sample the incubator's contents through the sample port located on the control panel bezel. Be sure that the stabilization times described earlier have been satisfied prior to performing this calibration. Press the advance key until the green display reads CAL (calibrate). Pressing the up arrow will increase the CO₂ calibration offset by 1%. Pressing the down arrow will decrease the CO₂ calibration offset by 1%. Pressing and holding either button will rapidly scroll the calibration offset. When finished, press the infinity key to return to the main menu.

Calibrating Optional Chart Recorders

For calibrating the optional front and side mounted chart recorders, refer section 6 (Optional Accessory Operation)

SECTION 8 – ALARMS

Alarm System Overview

The incubator control system is equipped with an alarm system that constantly monitors temperature, humidity and CO₂ to ensure the user is notified if the cabinet goes into an alarm condition. Notification occurs via a RED indicator light and an buzzer. Each alarm condition has been factory programmed to minimize nuisance alarms while maximizing warning time. The following table contains the alarm conditions being checked, the factory default alarm range, the amount of time an alarm must be present to occur (alarm delay), and the message that will be displayed on the individual system controller.

Alarm Description	Alarm Deviation	Alarm Delay	Alarm Message
Temp higher than Set-point	+1.0°C	15 minutes	Temp Controller – AL.h1
Temp lower than Set-point	-1.0°C	15 minutes	Temp Controller – AL.lo
RH higher than Set-point	+10% RH	15 minutes	RH Controller – AL.h1
RH lower than Set-point	-10% RH	15 minutes	RH Controller – AL.lo
CO ₂ higher than Set-point	+1.0%CO ₂	15 minutes	CO ₂ Controller – AL.h1
CO ₂ lower than Set-point	-1.0%CO ₂	15 minutes	CO ₂ Controller – AL.lo

In the event an alarm occurs, the alarm indicator will illuminate and an audible alarm will occur. To temporarily disable the audible alarm, toggle the alarm audible enable switch to silence. When the alarm condition is corrected both the alarm indicator and the audible alarm will be disabled. Return the alarm switch to audible.

Changing Alarm Set-points

All alarm set-points were preset at the factory to minimize nuisance alarms that could be created as a result of door openings. Alarm set-point defaults are shown in the alarm table earlier in this section. However, alarm set-points can be changed based on individual user requirements. Each of the controllers are programmed in the same manner. Press the advance key on the control system that you are changing until either A.LO1 or A.HI1 is displayed in green. The red displayed value is the deviation from the set-point that will activate the alarm. Press the UP arrow to increase the deviation, press the down arrow to decrease the deviation. Press the Infinity Key to exit.

SECTION 9 – PREVENTATIVE MAINTENANCE

The CARON incubator has been robustly designed to minimize performance problems. However, regular maintenance is very important for continuous trouble free operation.

As a general rule, CARON recommends an annual calibration check of the temperature, humidity and CO2 systems. CARON offers a full range of on-site calibration and validation services. We also offer preventative maintenance contracts on our equipment. Contact our service department for at 740-373-6809 details or visit us on the web at www.caronproducts.com.

Recommended Daily Maintenance Checks

- Check the Temperature, humidity, and CO2 displays versus set-points.
- Check for and correct any alarm condition.

Recommended Monthly Maintenance Checks

- Check to ensure the drain in the bottom of the unit is draining properly.
- Check front air intake filter. If it is dirty replace it with CARON part number FLTR303. Washing the filter will result in poor performance.

Recommended Annual Maintenance Checks

- Disinfect all interior surfaces with a general purpose laboratory cleaning agent.
- Perform a complete calibration of the temperature and humidity systems.
- A full validation is recommended for GMP facilities each time a unit is installed, moved or undergoes significant repair. Contact CARON's service department to schedule on-site validation.

SECTION 10 – SPECIFICATIONS

MODEL	6014	6016
Temperature Range	10°C Above Ambient to 60°C	5°C to 60°C
Temperature Control	± 0.1°C	
Temperature Uniformity	± 0.3°C	
Temperature Sensor	3-wire RTD	
Humidity Range	Ambient to 95% RH	
Humidity Control	± 3% RH	
Humidity Sensor	Capacitive	
CO2 Range	0-20% CO2	
CO2 Control	± 0.1% CO2	
CO2 Sensor	Infrared	
Interior Dimensions	23" W x 25.8" D x 29.8" H (58.4cm x 65.5cm x 75.7cm)	
Interior Construction	Type 304, 2B Finish, Solid Stainless Steel	
Exterior Dimensions	44.2" W x 32.6" D x 36.5" H (112.3cm x 82.8cm x 92.7cm)	
Exterior Construction	Cold Rolled Steel, Powder Coated	
Work Space	10 Cu. Ft. (283 Liters)	
# of Shelves	Three (3)	
Shelf Construction	Type 304, Perforated Stainless Steel, Electropolished	
Shelf Dimensions	29.2" W x 26.4" D (74.2cm x 67.1cm)	

	-1	-2	-3
Electrical	115V, 60 Hz, 12A	230V, 60 Hz, 8A	230V, 50 Hz, 6A
Shipping Weight	495 lbs.	495 lbs.	825 lbs.**

Specifications are subject to change without notice.

Environmental Conditions: Temperature 15°C to 25°C, Humidity non-condensing

**See graph for details*

***Includes export shipping crate*

This unit has forced internal air flow of 225 cfm (6,400 LPM)

SECTION 11 – ELECTRICAL SCHEMATICS

6016 REV-1 ELECTRICAL SCHEMATIC (PAGE 1 OF 3)

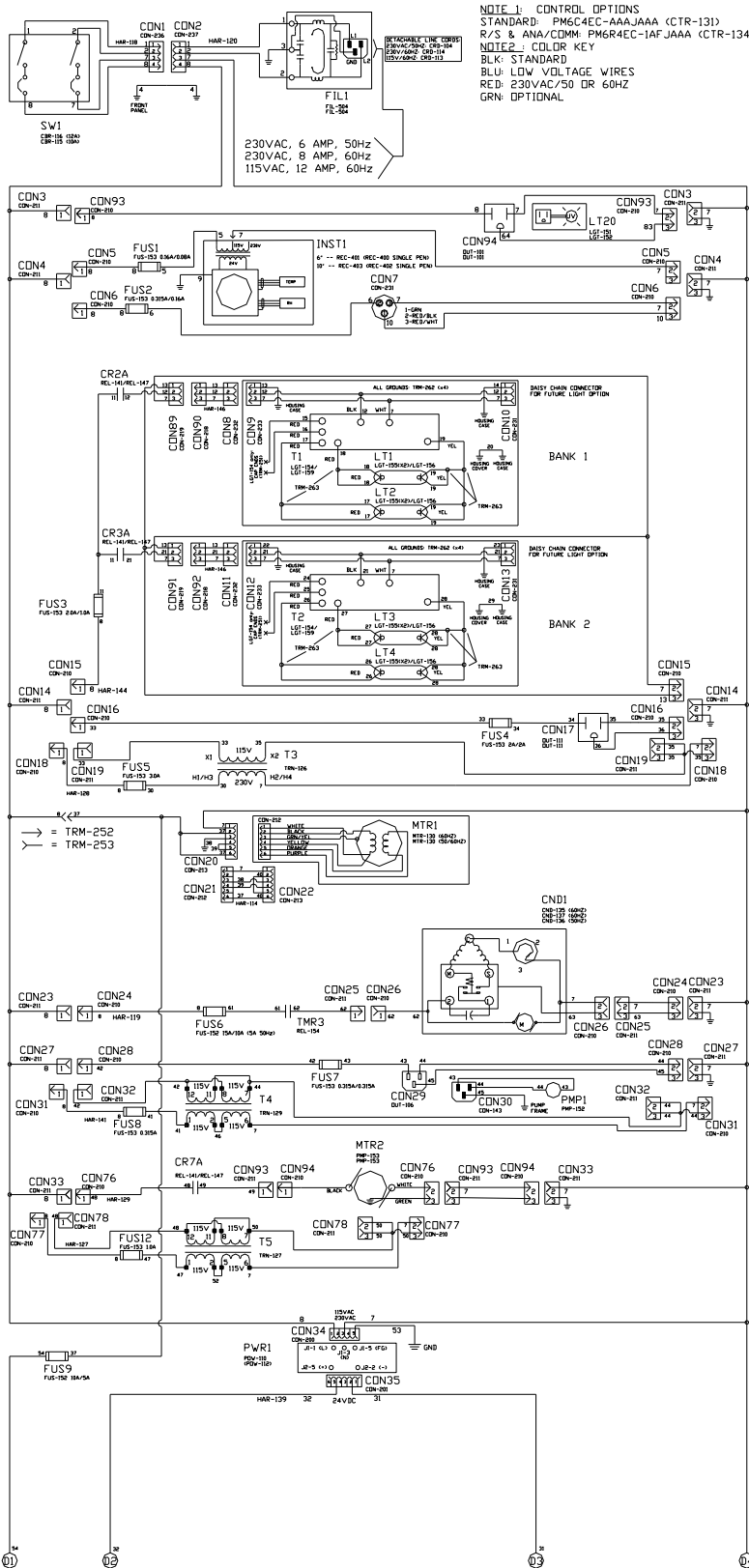

NOTE 1: CONTROL OPTIONS
 STANDARD: PM6C4EC-AAAJAA (CTR-131)
 R/S & ANA/COMM: PM6R4EC-1AFJAA (CTR-134)
NOTE 2: COLOR KEY
 BLK: STANDARD
 BLU: LOW VOLTAGE WIRES
 RED: 230VAC/50 OR 60HZ
 GRN: OPTIONAL

HIGHEST AC WIRE NUMBER: 64
 UNUSED WIRE NUMBERS: 65-99
 HIGHEST DC WIRE NUMBER: 187
 NOTE: 31 AND 32 ARE DC WIRE NUMBERS
 APPLIANCE COUPLER / EMI FILTER
 MAIN POWER SWITCH / CIRCUIT BREAKER
WIRE COLORS:
 HEAT: RED +24V/GND: PURPLE/BLK
 HUM: YELLOW AC PDWER: BROWN/LT BLUE
 DEHUM: PINK HV AC: 14GA
 LIGHTS: TAN LV DC: 18GA

CONNECTOR FOR OPTIONAL GERMICIDAL LIGHT
 OPTIONAL FRONT RECORDER ASSEMBLY
 (TRANSFORMER, RECORDER & PROBES)
 NOTE: SHARED CONNECTOR - ONLY FRONT 'DR'
 SIDE RECORDER AVAIL. ON UNIT
 OPTIONAL SIDE RECORDER OUTLET
 OPTIONAL FLUORESCENT TIMED LIGHTING
 WITH TWO LIGHT BANKS (LGT-303)
 (THE 6011 INCUBATOR BECOMES THE 6012
 DIURNAL INCUBATOR WITH THE ADDITION OF
 THE TIMED FLUORESCENT LIGHT OPTION.)
COMPONENT WIRE COLOR CODE:
 CON-231: 1=GRN, 2=RED/BLK, 3=RED/WHT
 CON-232: 1=GRN, 2=RED/BLK, 3=RED/WHT
 CON-233: 1=GRN, 2=RED/BLK, 3=RED/WHT

NOTE: SHARED CONNECTOR
 ONLY LIGHTS 'DR' OUTLETS AVAIL. ON UNIT
 OPTIONAL DUPLEX POWER OUTLET
 (GFCI FOR 115VAC AND 230VAC/60HZ ONLY)
 OUTLET XFMRMR, 250VA (60HZ ONLY)

CHAMBER AIR CIRCULATOR
 60HZ - 1725RPM
 50HZ - 1425RPM
 CHAMBER AIR CIRCULATOR
 ADAPTER CABLE FOR 230VAC 50/60HZ

CONDENSING UNIT WITH COMPRESSOR,
 THERMAL OVERLOAD, START RELAY AND FAN

CONDENSATE PUMP
 TRANSFORMER FOR CONDENSATE PUMP, 43VA

DE-HUM AIR PUMP

TRANSFORMER FOR DE-HUM PUMP, 175VA

POWER SUPPLY:
 24VDC, 100W, 85-264VAC INPUT
 (24VDC, 150W, 85-264VAC INPUT
 FOR USE WITH LED TIMED LIGHT
 AND/OR GASGUARD OPTIONS)

2/12/10

SECTION 11 – ELECTRICAL SCHEMATICS (CONT)

6016 REV-1 ELECTRICAL SCHEMATIC (PAGE 2 OF 3)

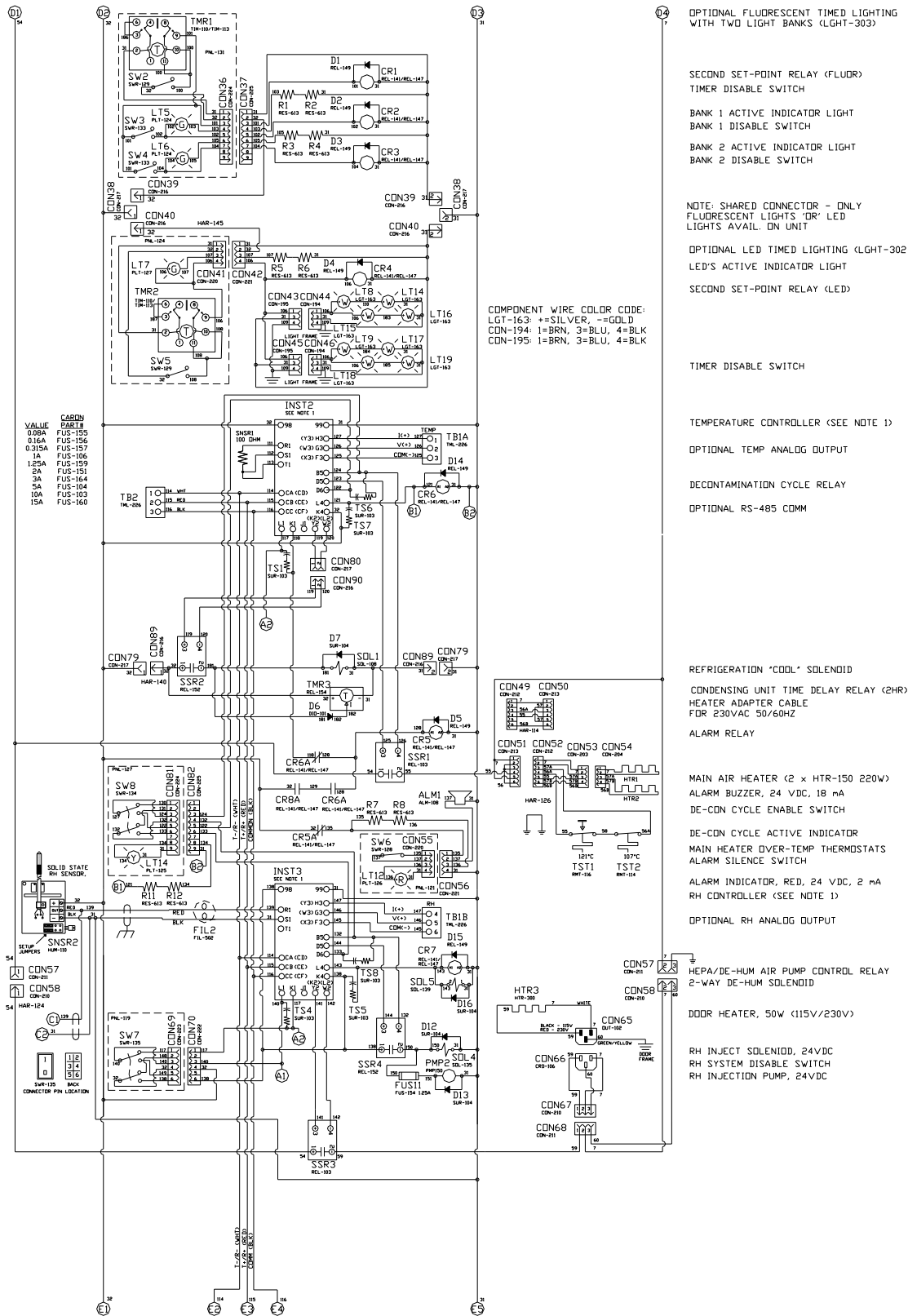

2/12/10

SECTION 11 – ELECTRICAL SCHEMATICS (CONT)

6016 REV-1 ELECTRICAL SCHEMATIC (PAGE 3 OF 3)

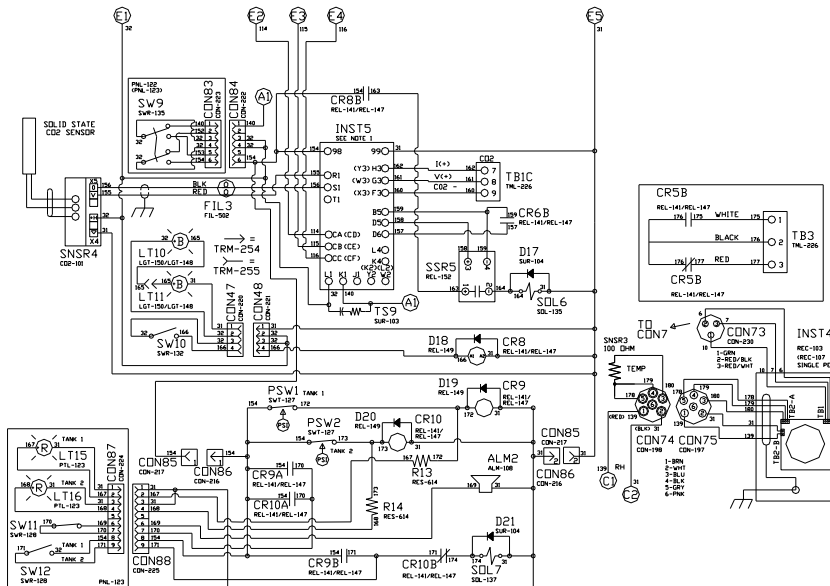

- CO2 CONTROLLER (SEE NOTE 1)
- CO2 SYSTEM DISABLE SWITCH
- OPTIONAL CO2 ANALOG OUTPUT
- DE-CON CYCLE ACTIVE CONTACTS
- OPTIONAL REMOTE ALARM CONTACTS
- LOGG ILLUMINATION, 24VDC
- CO2 INJECT SOLENOID, 24VDC
- DOOR SWITCH (CO2 INJECT DISABLE)
- DE-CON DOOR ALARM RELAY
- OPTIONAL SIDE RECORDER ASSEMBLY AND SENSOR CONNECTOR
- OPTIONAL GAS GUARD
- GAS-GUARD ALARM INDICATORS
- GAS-GUARD ALARM SILENCE SWITCH
- GAS-GUARD TANK SELECT SWITCH
- 3-WAY CO2 SOLENOID VALVE (OFF=TANK 1, ON=TANK 2)

2/12/10

SECTION 12 – TROUBLESHOOTING

Problem – Unit will not turn on

- Is the unit connected to a dedicated electrical circuit as defined in the installation section of the manual?
- Is there power at the electric outlet the unit is plugged into?
- Is the unit's power switch turned on?

Problem – Unit temperature is above / below temperature set-point

- Has the unit's temperature set-point been recently lowered / raised and if so has the unit been allowed 12 hours stabilize at the new set-point?
- Has the inner door been recently opened for an extended period of time?
- Is the access port stopper in the right side of the cabinet installed?
- Is the condenser filter on the front of the cabinet clean?

Unit humidity level is above / below humidity set-point

- Is the unit connected to a water source as specified in the installation section of the manual?
- Has the unit been leveled to insure the cabinet drain works correctly?
- The cabinet's drain line uses gravity to remove water. Does the drain line have any rises in it above the cabinet's drain level that could be trapping water?
- Has the unit's humidity set-point been recently lowered / raised and if so has the unit been allowed time to stabilize at the new set-point?
- Has the inner door been recently opened for an extended period of time?
- Is the access port stopper in the right side of the cabinet installed?
- Is the condenser filter on the front of the cabinet clean?

Unit CO2 level is above / below the CO2 set-point

- Is the unit connected to a pressure regulated CO2 source as specified in the installation section of the manual?
- Has the unit's CO2 set-point been recently lowered / raised and if so has the unit been allowed time to stabilize at the new set-point?
- Has the inner door been recently opened for an extended period of time?
- Is the access port stopper in the right and left side of the cabinet installed?

SECTION 13 – SPARE / REPLACEMENT PARTS

General

Part Number	Description
MTR-130	Blower Motor
BLW-113	Blower Wheel
CTR-132	Watlow Standard controller
CTR-134	Watlow Delux Controller
POW-108	24V DC Power Supply
FLTR303	Condenser Filter Replacement Kit
CRD-113	Power Line Cord
STP-101	2" Rubber Port Stopper

Temperature Related

Part Number	Description
HTR-150	Air Heater
RMT-114	107C Air Heater Thermostat
RMT-116	121C Air Heater Thermostat
RTD-101	Temp Sensor -- RTD 100 Ohm Platinum
REL-103	Heater Solid State Relay
CND-135	115V / 60Hz Condensing Unit
CND-137	230V / 60Hz Condensing Unit
CND-138	230V / 50Hz Condensing Unit
REL-152	Refrigeration Solid State Relay
REL-154	Refrigeration Time Delay Relay
SOL-108	Refrigeration Cooling Solenoid

Humidity Related

Part Number	Description
HUM-110	RH Sensor
PMP-150	24VDC RH Pressure Pump
NOZ-101	Precision RH Spray Nozzle
SOL-135	Humidification Solenoid
REL-152	Humidification Solid State Relay
TUB-168	Drain Tubing, Blue, 3/8"
TUB-132	Water Supply Tubing, Black, 1/4"

CO2 Related

Part Number	Description
CO2-101	Carbon Dioxide Sensor
SOL-135	CO ₂ Injection Solenoid
FIL-213	In-line CO ₂ HEPA Filter
FIL-115	HEPA Filter

Fuse Related

ID	Description	115V	230V
SW1	Main circuit breaker switch	CBR-116 (12A)	CBR-115 (10A)
FUS1	Front mount chart recorder fuse	FUS-156 (0.16A)	FUS-155 (0.08A)
FUS2	Side mount chart recorder fuse	FUS-157 (0.32A)	FUS-156 (0.16A)
FUS3	Internal duplex outlet fuse	FUS-151 (2A)	FUS-151 (2A)
FUS4	Internal outlet transformer fuse	-	FUS-164 (3A)
FUS5	Compressor fuse	FUS-160 (15A)	FUS-103 (10A)
FUS6	Condensate pump fuse	FUS-157 (0.32A)	FUS-157 (0.32A)
FUS7	Condensate pump transformer fuse	-	FUS-157 (0.32A)
FUS8	Air & door heater fuse	FUS-103 (10A)	FUS-104 (5A)
FUS11	Humidity injection pump fuse	FUS-159 (1.25A)	FUS-159 (1.25A)

Fuse Related

Part Number	Description	Option
CLM-132	Nylon Tube Clamp	GASG301, REGL101
FIT-342	¼" Barb – ¼" Push-in Adapter	GASG301, REGL101
LGT-134	UVA Replacement bulb (8 11/32" long)	LGHT602
LGT-156	24W HO Florescent Bulb	LGHT303
PEN-101	Red Pen for 10" Recorder	RCDR305, RCDR306
PEN-102	Purple Pen for 10" Recorder	RCDR306
PEN-103	Red Pen for 6" Recorder	RCDR301, RCDR302
PEN-104	Blue Pen for 6" Recorder	RCDR302
PPR-101	10" Recorder Paper 24hr/7day	RCDR305,RCDR306
PPR-104	6" Recorder Paper, 7 day 0-60C	RCDR301
PPR-105	6" Recorder Paper, 7 day 0-100C	RCDR302
PPR-106	10" Recorder Thermal Paper	RCDR303, RCDR304
TUB-145	¼" I.D. Vinyl Tubing	GASG301, REGL101
TUB-174	½" I.D. Silicone Tubing	PUMP301
WIR-102	20/3 Conductor Shielded Wire	ALRM301, SWFT103

SECTION 14 – ADVANCED USERS SECTION

Unlocking the Controllers



The temperature and humidity controllers are factory programmed for precise control. Unlocking the controllers gives the user access to all parameters. Modifying parameters that are not thoroughly understood can adversely affect incubator performance that will not be covered under warranty.

To unlock an individual controller

- 1) Press and hold the advance and infinity keys simultaneously for six seconds
- 2) Press the up key until LOC is displayed in the upper display
- 3) Press the advance key until rLoC is displayed in the lower display
- 4) Press the up key to change the security level from 2 to 5
- 5) Press the advance key until sLoC is displayed in the lower display
- 6) Press the up key to change the security level from 2 to 5
- 7) Press infinity key twice to return to the main menu

All controller parameters are now available to be modified. Once the appropriate changes have been made, it is highly recommended to relock the controllers per the instructions below.

Locking the Controllers

To lock an individual controller

- 1) Press and hold the advance and infinity keys simultaneously for six seconds
- 2) Press the up key until LOC is displayed in the upper display
- 3) Press the advance key until rLoC is displayed in the lower display
- 4) Press the up key to change the security level from 5 to 2
- 5) Press the advance key until sLoC is displayed in the lower display
- 6) Press the up key to change the security level from 5 to 2
- 7) Press infinity key twice to return to main menu

All controller parameters are now locked.



DECLARATION OF CONFORMITY

Caron Products and Services, Inc.
27640 State Route 7
Marietta, OH 45750 USA



Declares that the product:

Designation:	6014 Series
Model Numbers:	6014-3, 6016-3
Classification:	Electrical equipment intended for residential, commercial and lighting industrial environments
Rated Voltage:	220-240 ~ (ac)
Rated Frequency:	50Hz

Meets the essential requirements of the following European Union Directive(s) using the relevant section(s) of the normalized standards and related documents shown:

EMC

EN 61326 (CISPR 11: 2004 Class B) Laboratory Equipment, Immunity Measurement & Control requirements

Performed according to

EMC Directive 2004/108/EC
IEC/CISPR 11: 1997, +A1: 1999, +A2: 2002
EN 55011: 1998, +A1: 1999, +A2: 2002
FCC CFR47 Part 18

Safety

EN 61010-1 Safety requirements for electrical equipment for measurement, control, and laboratory use part 1: General Requirements

By: Dave Figel
Engineering/Production Manager
CARON Products & Services, Inc.