

FMN S5000

Instructions for use



Safety precautions

- The coin-operated telephone is a wall-mounted payphone for connection to analogue telephone lines via TAE plug. The 16 (12) kHz metering pulse is absolutely necessary for correct functioning and charging. It can be connected to both main lines and extensions.
- Always remove the telephone connecting cord and the cord of the power supply before opening the FMN S5000! (Exception: when initiating the service program. You may press the designated service key located inside the casing only (see picture on page 50)).
- Allow repairs by authorised specialists only!
- Do not use or install your payphone in rooms with danger of explosion and near electromagnetic fields (e. g. domestic appliances, TV or video recorders)!
- The telephone is not splash-proof. For your own safety, do not operate the telephone in damp environments such as bathrooms, showers etc.!
- The last step before beginning operation after mounting is to plug the telephone connecting cord into the wall socket and the plug of the power supply into the mains socket!
- The first step when ending operation is to remove the telephone connecting cord from the wall socket and the plug of the power supply from the mains socket!
- The telephone connecting cord is only to be plugged into the designated socket!
- The plug of the power supply and the telephone connecting cord are immediately to be removed from the socket in case of danger of touching conductive parts due to improper use!
- Using the telephone during thunderstorms is on one's own risk!
- The telephone should only be passed on to third parties if the operating instructions are included!
- When the telephone has reached the end of its service life, it should be disposed of in an environmentally friendly manner!
- **Danger in case of noncompliance with safety precautions**
The payphone is state of the art technology. However, it may be dangerous if it is not mounted or installed by qualified personnel.
- **Prohibition to make any changes or modifications.**
The mechanical design as well as all safety-related matters of the payphone may not be changed or modified without prior and express consent of the manufacturer. In no event shall FMN be liable for any damages caused by such unauthorised changes of modifications. Especially all kinds of repair and soldering works on the main board (PBC) are prohibited.



ESD protection measures

Comply with the ESD protection measures according to DIN EN 61340-5-1/-2 when opening the unit (potential equalization between body and ground of the phone as well as ground of the casing via high-value resistance (approx. 1 M Ω) e.g. usual wrist band).

Table of contents

Safety precautions	2
Mounting and putting into operation	5
Delivery scope	7
Default settings	7
Important information	8
Mounting	9
Tools required for mounting	9
Putting into operation	10
Removing / inserting the labelling card	10
The PIN	11
Overview of settings	12
Starting the settings program and viewing the current settings	12
Statistics	14
Table of settings	14
Restoring the factory preset	16
Selecting the language	18
Setting the language	18
Selecting the language before conducting a call	19
Selecting the language after starting a call	20
Selecting the language at an incoming call	20
Temporary internal coin storage and cash box	21
Temporary internal coin storage	21
Emptying the cash box	21
Settings for the internal cash box	22
Setting the various cash functions	23
Coins; barring and accepting coins	23
Coin check	24
Setting the minimum amount (first unit) and the following units	25
Telephone settings	27
List of barred call numbers	27
You want to conduct a call	28
Visual and acoustical request to insert more coins	28
Using the credit for another call if the previous was unsuccessful	28
Last number redial	28
Using the remaining credit for another call if the previous was successful	29
Fast dialling	29
Setting the dialling method	30
Automatic public line access	31
Display messages	33

Table of contents

Settings for incoming calls	34
Activating / deactivating incoming call acceptance	34
Electronic ringer	34
ID tone (Payphone Recognition Tone)	35
Call numbers with special charges	37
Information	37
Call numbers with block tariffing	41
Automatic detection of call number areas with block tariffing	42
Device-specific settings	44
Setting your individual text	44
The text editor	45
Setting the external power feeding	47
Technical data / Connection permit	48
Technical data	48
Connection permit	48
Troubleshooting	49
Procedure in case of malfunction	49
Cleaning	49
Instructions for using the self test	50
Monitoring functions	52
Reporting of cash box content and error messages / remote reporting	52
Setting of remote access	53
Monitoring metering pulses / metering pulse check	54
Setting metering pulse monitoring	55
Menu structure	56

Mounting and putting into operation

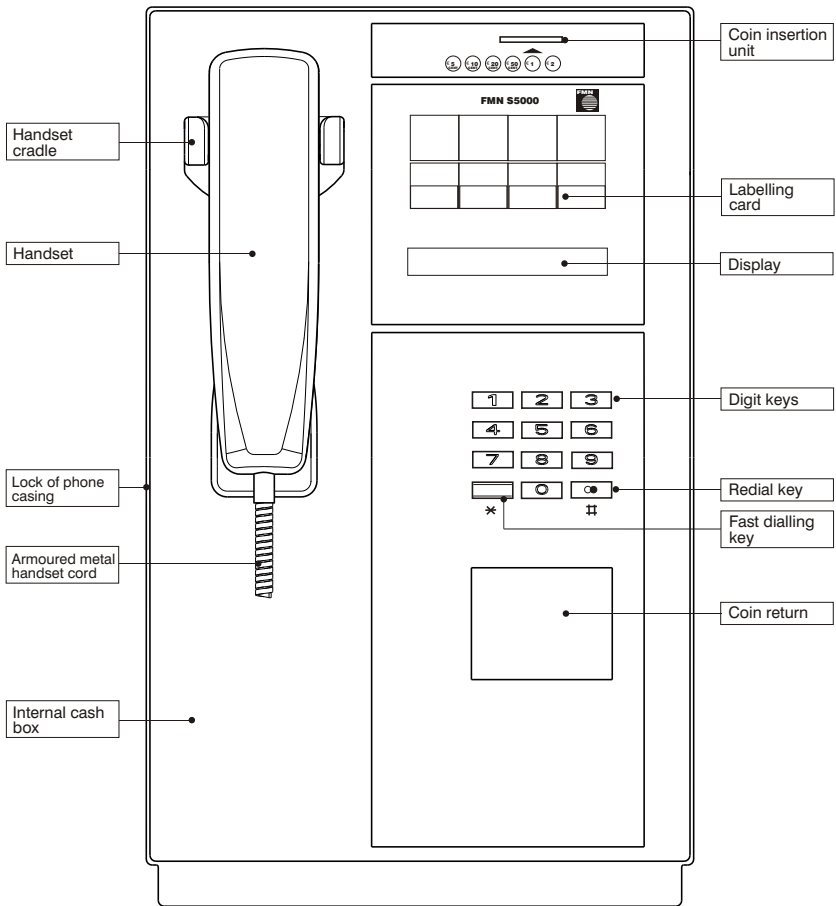

Mounting and putting into operation

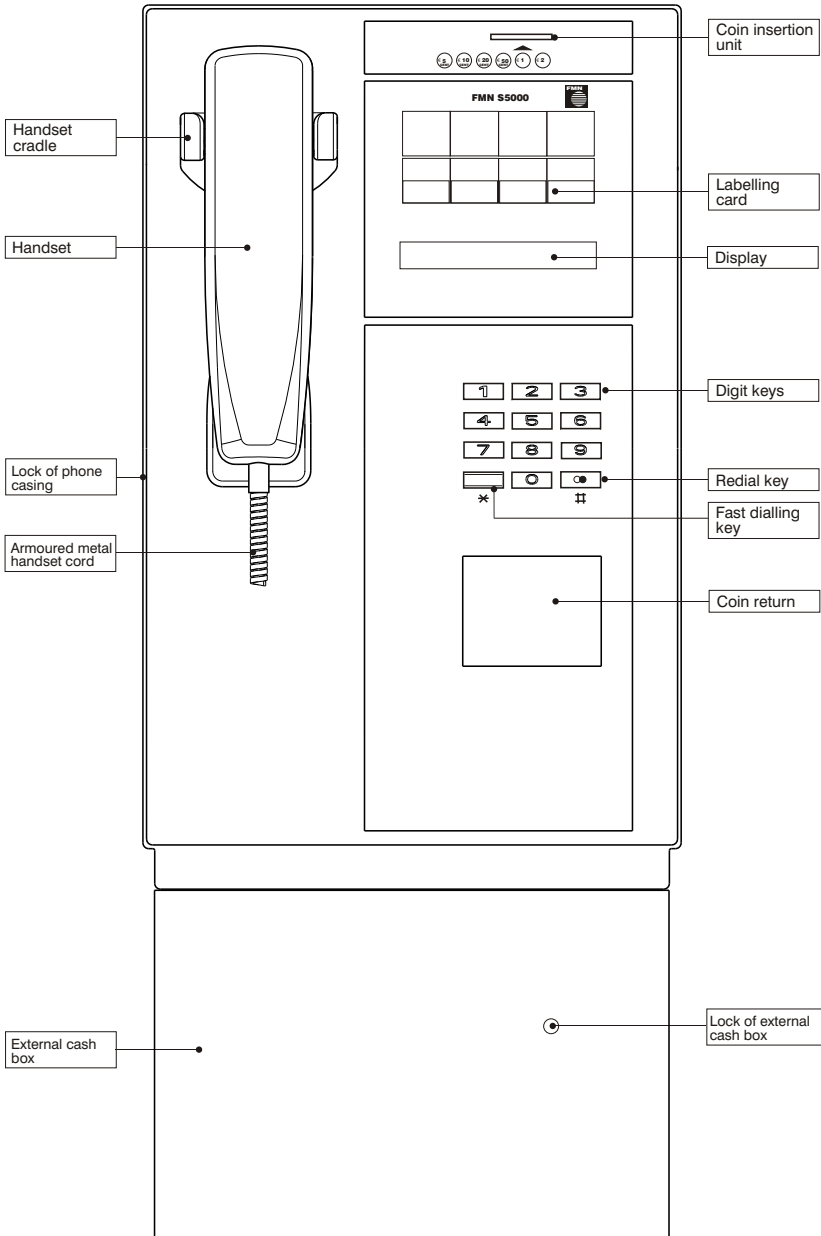

Coin-operated Telephone FMN S5000 with external cash box

Mounting and putting into operation

Delivery scope

- 1 coin-operated payphone FMN S5000 with wall power supply (or 1 coin-operated payphone FMN S5000 with external cash box)
- 2 keys
- 2 labelling cards
- 1 sticker without labelling for fast dialling key
- 1 labelled sticker for hotel, taxi
- 1 drilling template
- 3 hexagon-head screws 8x60 DIN 571
- 3 dowels GD 10
- 3 washers 8.4 DIN 433
- this instruction for use

The coin-operated payphone FMN S5000 is supplied with two identical keys for the phone casing and two identical keys for the internal cash box. Please keep the keys in a safe place. For safety reasons, no back-up service is provided. In case of loss, it is not possible anymore to open the unit and empty the cash box.

Default settings

- PIN: 0000
- Currency: €
- Minimum amount (first unit): € 0.15
- Amount of following units: € 0.15
- Dialling method: DTMF
- Incoming call acceptance: on
- ID tone (Payphone Recognition Tone): on
- Ringer: on, Ringer volume: level 9
- Automatic public line access: off
- Coin acceptance: all € coins are accepted
- Ringer via handset: off
- Fast dialling: not set
- Coin check: on
- Trunk code: not set
- Pulse monitoring: on; absent: short
- External power feeding: network
- External cash box: off; maximum volume 1050 ml
- Individual text: not set; description field: empty
- Emergency call numbers: Germany 110, 112: coinfree
Austria 12, 13, 14: coinfree
Luxembourg 112, 113: coinfree
- Tollfree numbers that require insertion of coins:
Germany: 0800..., 00800..., 0181...,
Austria: 11..., 0800..., 0801..., 0802...,
0803..., 0804..., 00800...
Luxembourg: none

Mounting and putting into operation

- Barred call numbers (see page 27)
- Call number areas with block tariffing (tariffs already preprogrammed):

Germany:

0150..., 0151..., 0152..., 0156..., 0160..., 0162..., 0163..., 0170...,
0171..., 0172..., 0173..., 0174..., 0175..., 0176..., 0177..., 0178...,
0179..., 001..., 001787..., 001939..., 0030..., 0031..., 0032..., 0033...,
0034..., 00350..., 00351..., 00352..., 00353..., 00354..., 00355..., 00356...,
00357..., 00358..., 00359..., 0036..., 00370..., 00371..., 00372..., 00373...,
00375..., 00376..., 00377..., 00378..., 00380..., 00381..., 00385..., 00386...,
00387..., 00389..., 0039..., 0040..., 0041..., 00420..., 00421..., 00423...,
0043..., 0044..., 0045..., 0046..., 0047..., 0048..., 0090...

Austria:

no preprogrammed numbers

Luxembourg:

no preprogrammed numbers

Important information

- The FMN S5000 requires a **16 (12) kHz metering pulse** for correct operation as a payphone.
Before installing the FMN S5000, please instruct your network operator to order the metering pulses in addition to the normal telephone line (subject to charge). If you want to operate the FMN S5000 at a PABX, you have to make sure that the metering pulse gets through to your payphone.
- For your own protection, certain call numbers are barred (see page 27).
- In case of an incoming call, the FMN S5000 sends an ID tone (Payphone Recognition Tone) several times after the handset is lifted. The ID tone identifies your telephone as a payphone in order to prevent calls via operator (e. g. collect calls). The ID tone can be disabled, but then the FMN S5000 cannot be identified as a payphone anymore.

For your own protection, please do not disable the ID tone.

- As with any coin-operated device, it could be possible that, under certain circumstances, the FMN S5000 might accept coins which it is not supposed to accept. To avoid such problems, see chapter "Coins; barring and accepting coins" (see page 23).
- Make sure that the **telephone connecting cord and the wall socket are not accessible to strangers**. This is the only way to avoid manipulation.
- It is absolutely necessary **to empty the cash box each time the cash box door is opened** (also if you want to check or change settings), otherwise you may encounter problems. The FMN S5000 assumes that the cash box will be emptied each time the cash box door is unlocked.
- If you are not going to use the fast dialling feature, we nevertheless recommend to label the fast dialling key with one of the stickers provided in order to avoid dirt getting into the key recess (for labelling the sticker, see page 30).

Mounting and putting into operation

- If the FMN S5000 is operated on an automatic switch, call hand-over from the FMN S5000 to another phone is possible. Call take-over from another phone to the FMN S5000 is not possible.
- Service program:
Before effecting any changes in the service program, inform yourself about the difficulties in order to avoid suffering financial damages.
We recommend only to effect changes in the service program that are absolutely necessary.

Mounting

Before mounting the FMN S5000, choose a suitable location (vertical wall - use a spirit level). When drilling, take care not to damage or destroy any cables located in the wall. The weight of the FMN S5000 is approx. 12 kg with full internal cash box, hence, make sure that the wall is stable enough to hold that weight. Also follow the instructions on the drilling template when mounting. Make sure that the **wall socket and the mains socket are not accessible to unauthorised persons** in order to avoid manipulation. You are liable for any damages incurred during mounting or connecting the unit.

Do not expose the product

- to extreme temperatures or high solar radiation
- to high humidity and moisture
- to water / splash or chemicals
- to vibration or shock
- near units causing high electromagnetic interference.

Tools required for mounting

- power drill and drill bit (diameter 10 mm)
- spanner SW 13

Mounting and putting into operation

Putting into operation

- The *first step* when putting the FMN S5000 into operation after mounting is to plug in the telephone connecting cord in the wall socket and *the last step* is to plug in the wall power supply.
- It could be possible that the internal power supply (gold cup) of the FMN S5000 has not been sufficiently charged before you install the payphone for the first time. In order to charge the gold cap, the handset must be off-hook until the message "Minimum € 0.15" appears in the display.
- **Charging the gold cap may take several minutes.**
The gold cap remains charged even though the payphone is **not** used daily.
- Please fill in the labelling card (owner, location number).

Removing / inserting the labelling card

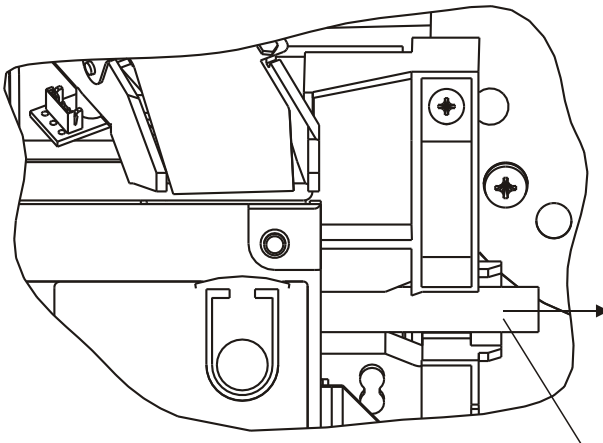

remove the labelling card

turn it upside down and fill in the marked fields













insert the labelling card

Mounting and putting into operation

The PIN

The PIN is a code with 4 digits that secures access to the service and settings program. This securing shall avoid that people that were not authorised by your side have access to the settings of the software of the FMN S5000 and are able to manipulate these.

The PIN is preprogrammed by default with "0000". But the PIN can be set individually by you.

	Open phone casing and take out the cash box! (see page 21)	Empty cash box!
	(Handset must be on-hook!)	Settings
	Confirm	PIN ????
	Enter PIN (4 digits)	PIN ****
		Information
	Enter digits 18	** PIN
	Confirm setting	PIN ???? ???? ?
	Enter new PIN (4 digits)	PIN **** ???? ?
	Repeat new PIN (4 digits)	PIN **** ****
	Confirm setting	Exit function
	Exit this function or settings program	Exit settings
	Confirm setting	Del. meter? no
	Change setting no / yes	Del. meter? yes
	Confirm setting	
	Empty cash box! Put cash box back into the phone!	

** the menu "changing PIN" is only accessible via the digit code

Note!























In case that your individually programmed PIN gets lost, it can be put back to factory preset at works (please send your FMN S5000 in) or at the face by a specialist authorised by the company.

Overview of settings

Starting the settings program and viewing the current settings

All current settings of your FMN S5000 can be viewed as follows:

The handset must be on-hook. If you do not press any key for 60 s, the FMN S5000 automatically exits the settings program.

	Open phone casing and take out cash box!	Empty cash box!
	(Handset must be on-hook!)	Settings
	Confirm	PIN ?????
	Enter PIN (4 digits)	PIN ****
		Information
	Confirm setting	Minimum 00.15 €
	Scroll to	Unit 00.15 €
	Scroll to	Dialling DTMF
	Scroll to	Inc. call on
	Scroll to	Ringer on
	Scroll to	Ringer volume 9
	Scroll to	ID tone on
	Scroll to	Line acces
	Confirm setting	Line access off
	Scroll to	Exit function
	Confirm setting	Line access
	Scroll to	Coin check on
	Scroll to	Rem. report
	Confirm setting	Rem. report off
	Scroll to	Exit function
	Confirm setting	Rem. report
	Scroll to	Pulse monit. on
	Scroll to	Fast dial
	Confirm setting	Fast dial off

Overview of settings

<input type="checkbox"/>	Scroll to	Exit function
<input checked="" type="checkbox"/>	Confirm setting	Fast dial
<input type="checkbox"/>	Scroll to	Special number
<input checked="" type="checkbox"/>	Confirm setting	110
<input type="checkbox"/>	Scroll through further settings	
	⋮	
<input type="checkbox"/>	Scroll to	Exit function
<input checked="" type="checkbox"/>	Confirm setting	Special numbers
<input type="checkbox"/>	Scroll to	Statistics
<input checked="" type="checkbox"/>	Confirm setting	SFU 0
<input type="checkbox"/>	Scroll through further settings	
	⋮	
<input type="checkbox"/>	Scroll to	Exit function
<input checked="" type="checkbox"/>	Confirm setting	Statistics
<input type="checkbox"/>	Scroll to	Version
<input checked="" type="checkbox"/>	Confirm setting	V21.1CXX.XX
<input checked="" type="checkbox"/>	Confirm setting	Exit function
<input type="checkbox"/>	Exit this function or settings program	Exit settings
<input checked="" type="checkbox"/>	Confirm setting	Del. meter? no
<input type="checkbox"/>	Change setting no / yes	Del. meter? yes
<input checked="" type="checkbox"/>	Confirm setting	
	Empty cash box!	
	Put cash box back into the phone!	

Overview of settings

Statistics

The following counters are only installed in the FMN S5000 to your information:

- SFU: counter of all metering pulses paid by the user; **can be deleted ***
- TFU: counter of all metering pulses paid by the user; **cannot be deleted**
- SU: counter of all metering pulses received from the telephone line; **can be deleted ***
- TU: counter of all metering pulses received from the telephone line; **cannot be deleted**
- SFS: counter of the total amount of money charged by the phone; **can be deleted ***
- TFS: counter of the total amount of money charged by the phone; **cannot be deleted**
- Volume xxx ml: current content of the internal cash box / external cash box in ml; reset to 0 is automatic
- Volume xxx %: current content of the internal cash box / external cash box in %; reset to 0 is automatic

Deriving any legal claims from any of these counters is excluded!

All counters that can be deleted can only be deleted together by using the relevant procedure when exiting the settings program (see e.g. page 12). This procedure is only available after input of the PIN.

* by confirming the following display message Del. meter? yes via the  key, the counter will be reset to "0"

Table of settings

The following table is an overview of all settings you can adjust via the settings program of the FMN S5000. All values and settings are explained in detail on the following pages. Please pay attention to the marked notes in the following table:

*) accessible via service program only

Description Main menu	see page	Possible settings	Code
Information	12	Settings, call numbers	0 1
Available languages	18	German, Dutch, English, French, Spanish	0 2
Standard language	18	German, Dutch, English, French, Spanish	

Overview of settings

Minimum amount (€)	25	€ 0.00 to € 4.50 in steps of € 0.01	0 3
Amount of following units (€)	25	€ 0.05 to € 4.50 in steps of € 0.01	
Dialling method	30	dual-tone multifrequency (DTMF); Pulse Dialling (Pulse)	0 4
Incoming call acceptance	34	on / off	0 5
ID tone *)	35	on / off	
Ringer	34	on / off	
Ringer volume	34,35	0; 1; 2; 3; 4; 5; 6; 7; 8; 9	
Automatic public line access	31	on / off	0 6
Flash	31	on / off	
Flash time	31,32	50 ... 990 ms	
Trunk code	30,32	any trunk code incl. dial pause, max. 10 digits	
Currency	23 ff	€	0 7
Acceptance of € 0.05	23	on / narrow / bar coin	
Acceptance of € 0.10	23	on / narrow / bar coin	
Acceptance of € 0.20	23	on / narrow / bar coin	
Acceptance of € 0.50	24	on / narrow / bar coin	
Acceptance of € 1.00	24	on / narrow / bar coin	
Acceptance of € 2.00	24	on / narrow / bar coin	
Fast dialling	29	on / off / coinfree / normal / numbers	0 8
Special call numbers	38	to enter; delete; bar call numbers; to set call numbers coinfree; to set call number areas coinfree; tollfree; with one single charge; with cyclic block tariff; with normal block tariff; with secure tariff; with secure minimum amount; with absolute special tariff; with normal self tariff; with extended self tariff	
Coin check	24	on / off	0 9
Remote reporting	53	on / off	1 0
Reporting via	53,54	Tones / DTMF	
Amount of dial tones	53,54	1 ... 15	

Overview of settings

Metering pulse monitoring	55	on / off absent long / short	<input type="text" value="1"/> <input type="text" value="1"/>
Volume of cash box	22	maximum content of the cash box without external cash box 1050 ml; with external cash box 1650 ml or editable	<input type="text" value="1"/> <input type="text" value="2"/>
Restoring factory preset	16		<input type="text" value="1"/> <input type="text" value="3"/>
Self test *)	50		<input type="text" value="1"/> <input type="text" value="4"/>
External power feeding	47	setting power feeding network / battery	<input type="text" value="1"/> <input type="text" value="5"/>
Individual text	44	entering an user-defined display message in idle condition instead of displaying the designation of the device	<input type="text" value="1"/> <input type="text" value="6"/>
Exit settings		to exit the settings program	<input type="text" value="1"/> <input type="text" value="7"/>
Changing PIN	11	entering an individual PIN	<input type="text" value="1"/> <input type="text" value="8"/>

Restoring factory preset

You can restore all settings of the factory preset of your FMN S5000 (see page 7). Note that all your individually programmed settings and call numbers will be deleted.



Open phone casing and take out cash box!

Empty cash box!

(Handset must be on-hook!)

Settings



Confirm

PIN ?????



Enter PIN (4 digits)

PIN ****

Information



Enter digits 13

Factory settings



Confirm setting

Min./ unit no



Change setting no / yes

Min./ unit yes



Confirm setting

Dialling no



Change setting no / yes

Dialling yes



Confirm setting

Inc. call no



Change setting no / yes

Inc. call yes

Overview of settings

<input checked="" type="checkbox"/>	Confirm setting	Line access no
<input type="checkbox"/>	Change setting no / yes	Line access yes
<input checked="" type="checkbox"/>	Confirm setting	Coin denom. no
<input type="checkbox"/>	Change setting no / yes	Coin denom. yes
<input checked="" type="checkbox"/>	Confirm setting	Fast dial no
<input type="checkbox"/>	Change setting no / yes	Fast dial yes
<input checked="" type="checkbox"/>	Confirm setting	Special # no
<input type="checkbox"/>	Change setting no / yes	Special # yes
<input checked="" type="checkbox"/>	Confirm setting	Block tariff. no
<input type="checkbox"/>	Change setting no / yes	Block tariff. yes
<input checked="" type="checkbox"/>	Confirm setting	Coin check no
<input type="checkbox"/>	Change setting no / yes	Coin check yes
<input checked="" type="checkbox"/>	Confirm setting	Rem. report no
<input type="checkbox"/>	Change setting no / yes	Rem. report yes
<input checked="" type="checkbox"/>	Confirm setting	Pulse monit. no
<input type="checkbox"/>	Change setting no / yes	Pulse monit. yes
<input checked="" type="checkbox"/>	Confirm setting	Max vol. no
<input type="checkbox"/>	Change setting no / yes	Max vol. yes
<input checked="" type="checkbox"/>	Confirm setting	Statistics no
<input type="checkbox"/>	Change setting no / yes	Statistics yes
<input checked="" type="checkbox"/>	Confirm setting	Exit function
<input type="checkbox"/>	Exit this function or settings program	Exit settings
<input checked="" type="checkbox"/>	Confirm setting	Del. meter? no
<input type="checkbox"/>	Change setting no / yes	Del. meter? yes
<input checked="" type="checkbox"/>	Confirm setting	
	Empty cash box!	
	Put cash box back into the phone casing!	

Selecting the language

Language settings

The FMN S5000 enables a setting of languages depending on location for the duration of a call or of successive calls (handset is on-hook between calls for less than 1.5 s), as well as the choice of an offered language for use in the settings program.

The following possibilities are offered













a) Enabling / disabling a language

The user can choose among the enabled languages before conducting a call. The standard (basic) language set by default for a configuration cannot be disabled.

b) Standard (basic) language

This standard language is used during normal telephone operation, in the settings and service program and comes up first if the user wants to select a different language before conducting a call.

The languages offered are set by enabling / disabling a language.

	Open phone casing and take out cash box!	Empty cash box!
	(Handset must be on-hook!)	Settings
	Confirm	PIN ????
	Enter PIN (4 digits)	PIN ****
		Information
	Enter digits 02	Language
	Confirm setting	Avail. language
	Confirm setting	German X
	Change setting X / - (cannot be disabled)	German X
	Scroll to	English X
	Change setting X / - (disable)	English -
	Change setting X / - (disable)	English X
	Scroll to	French X
	Change setting X / - (disable)	French -
	Scroll to	Spanish X

Selecting the language

- | | | |
|-------------------------------------|---|----------------|
| <input checked="" type="checkbox"/> | Change setting X / - (disable) | Spanish - |
| <input type="checkbox"/> | Scroll to | Dutch X |
| <input checked="" type="checkbox"/> | Change setting X / - (disable) | Dutch - |
| <input type="checkbox"/> | Scroll to | Basic language |
| <input checked="" type="checkbox"/> | Confirm the setting (current basic language comes up) | German X |
| <input type="checkbox"/> | Scroll to | English - |
| <input type="checkbox"/> | Change setting X (select) | English X |
| <input checked="" type="checkbox"/> | Confirm (new basic language is selected) | Exit function |

Selecting the language before conducting a call

The user of the FMN S5000 can select one of the available languages enabled in the settings program for user guidance before conducting a call (handset is on-hook for longer than 1.5 s).

This selection is valid for approx. 10 s. The handset needs to be lifted within that time to activate the selected language during the following call or calls.

Handset is on-hook for longer than 1.5 s

- | | | |
|---|---------|-----------------|
| | | FMN S5000 |
| <input checked="" type="checkbox"/> | Confirm | Englisch |
| | | for approx. 2 s |
| <input checked="" type="checkbox"/> | Confirm | Francais |
| | | for approx. 2 s |
| a) the handset is lifted within 10 s | | Attendez svp |
| b) the handset remains on-hook for longer than 10 s | | Deutsch |
| | | for approx. 2 s |
| | | FMN S5000 |

After finishing the call (handset is on-hook for longer than 1.5 s), the payphone automatically returns to the standard language set in the settings.

Selecting the language

Selecting the language after starting a call

After lifting the handset, the user can as well select one of the available languages until dialling the first digit.

Selecting the language can be activated by actuating the  key. After actuation of the key, the selected language is shown for approx. 2 s, after that, the current indication is restored in the selected language.

Selecting the language at an incoming call

In case of an incoming call, a language can also be selected via the  key. The way of function is similar to selecting the language after starting a call.

Temporaty internal coin storage and cash box

Temporary internal coin storage

The FMN S5000 has two temporary coin storages. One can store a maximum of 5 coins (€ 0.05, € 0.10), the other a maximum of 2 coins (€ 0.20, € 0.50, € 1, € 2).

Before conducting a call, up to 7 coins can be inserted (maximum credit € 4.50). Coins can be inserted any time during the call as soon as coins which have already been cashed during the call have been transported into the cash box. Hence, there is enough space for new coins in the temporary coin storage.

Emptying the cash box

The cash box of the FMN S5000 has a capacity of approx. 900 pieces of € 0.05 coins, the capacity of the cash box of the FMN S5000 with external cash box is approx. 1400 pieces of € 0.05 coins. The amount of coins in the cash box is controlled electronically. The FMN S5000 deactivates itself when the cash box is full and the message "Emerg. calls only" appears in the display.

To remove the cash box, you have to open the phone with the key on the left side. Now you can pull out the cash box of the front flap of the casing to the back. By removing the cash box, the access to the settings program is activated at the same time.

Note:

The cash box **must** be emptied each time it is taken out of the casing, even though it is not full. If you do not empty the cash box, you may encounter problems.

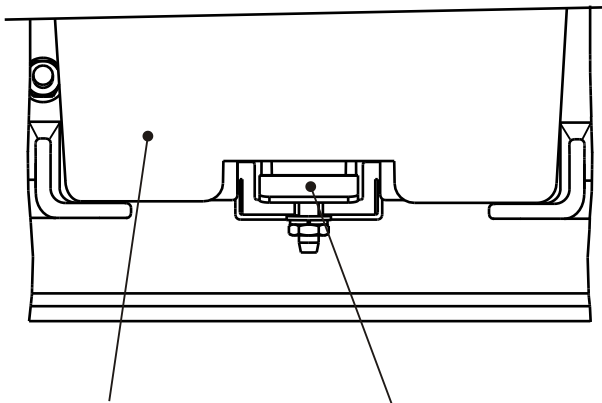

cash box

press the retaining spring down
and pull out the cash box

Temporary internal coin storage and cash box

Settings for the internal cash box

The FMN S5000 is equipped suitably to standards with an internal cash box. But should external cash boxes or modified cash boxes be put into the FMN S5000, the maximum volume of the changed cash box has to be indicated to guarantee a proper function of the FMN S5000. The value of the volume that has to be given result of the actual volume of the cash box multiplied by a factor of 0.8, since space is wasted because the coins are not stored orderly.



Open phone casing and take out cash box!

Empty cash box!

(Handset must be on-hook!)

Settings



Confirm

PIN ?????



Enter PIN (4 digits)

PIN ****



Enter digits 12

Information

Ext.cash box



Confirm setting

Ext.cash box off



Change setting on / off

Ext.cash box on



Confirm setting

Max Vol. 01650ml



Enter new value

Max Vol. 01500ml



Confirm setting

Exit function



Exit this function or settings program

Exit settings



Confirm setting

Del. meter? no



Change setting no / yes

Del. meter? yes



Confirm setting

Empty cash box!
Put cash box back into the phone!

Setting the various cash functions

Coins; barring and accepting coins

The FMN S5000 accepts, € 0.05; € 0.10; € 0.20; € 0.50; € 1 and € 2 coins, depending on the setting.

Unused coins will be returned.

If you do not want the payphone to accept a certain coin denomination, you can bar that coin denomination.

As with any coin-operated device it could be possible that, under certain circumstances, the FMN S5000 may accept **coins which it is not supposed to accept**.

In order to avoid such problems

- a) You can intensify the coin validation procedure for the relevant € coin by setting the coin acceptance to "narrow". It may be possible that very few € coins of this coin denomination will then be rejected by the coin validation (which are within the tolerance limit).
- b) The acceptance of the respective € coins - and thus the acceptance of the coins that should not be accepted - can be barred totally (a maximum of five € coin denominations).



Open phone casing and take out cash box!

Empty cash box!

(Handset must be on-hook!)

Settings



Confirm

PIN ????



Enter PIN (4 digits)

PIN ****



Enter digits 07

Information

Currency



Confirm setting

Currency €



Confirm setting

0.05 € on



Select enabled (on) / narrow

0.05 € narrow



Select narrow / barred

**

0.05 € barred



Confirm setting

0.10 € on



Select enabled (on) / narrow

0.10 € narrow



Select narrow / barred

**

0.10 € barred



Confirm setting

0.20 € on



Select enabled (on) / narrow

0.20 € narrow

Setting the various cash functions

<input type="checkbox"/>	Select narrow / barred	**	0.20 € barred
<input checked="" type="radio"/>	Confirm setting		0.50 € on
<input type="checkbox"/>	Select enabled (on) / narrow		0.50 € narrow
<input type="checkbox"/>	Select narrow / barred	**	0.50 € barred
<input checked="" type="radio"/>	Confirm setting		1.00 € on
<input type="checkbox"/>	Select enabled (on) / narrow		1.00 € narrow
<input type="checkbox"/>	Select narrow / barred	**	1.00 € barred
<input checked="" type="radio"/>	Confirm setting		2.00 € on
<input type="checkbox"/>	Select enabled (on) / narrow		2.00 € narrow
<input type="checkbox"/>	Select narrow / barred	**	2.00 € barred
<input checked="" type="radio"/>	Confirm setting		Exit function
<input type="checkbox"/>	Exit this function or settings program		Exit settings
<input checked="" type="radio"/>	Confirm setting		Del. meter? no
<input type="checkbox"/>	Change setting no / yes		Del. meter? yes
<input checked="" type="radio"/>	Confirm setting		
	Empty cash box!		
	Put cash box back into the phone!		

** You cannot bar all coin denominations simultaneously.

Coin check

Every time the handset of the FMN S5000 is lifted, the phone executes an additional cashing procedure in order to transport coins which have not been cashed properly due to dirt, grease etc. into the cash box. This coin check takes a few seconds. When the message "minimum..." appears in the display, the FMN S5000 is ready for use.

This **coin check feature** can be deactivated. With the coin check deactivated, the FMN S5000 is immediately ready for use when the handset is lifted.

We recommend not to deactivate the coin check feature!

	Open phone casing and take out cash box!	Empty cash box!
	(Handset must be on-hook!)	Settings
<input checked="" type="radio"/>	Confirm	PIN ????

Setting the various cash functions



Enter PIN (4 digits)

PIN ****



Enter digits 09

Information

Coin check



Confirm setting

Coin check on



Change setting on / off

Coin check off



Confirm setting

Exit function



Exit this functions or settings program

Exit settings



Confirm settings

Del. meter? no



Change setting no / yes

Del. meter? yes



Confirm setting
Empty cash box!
Put cash box back into the phone!

Setting the minimum amount (first unit) and the amount for the following units

You can set different amounts for the first unit and for the following units.

The minimum amount (first unit) of the FMN S5000 can be set between € 0.00 and € 4.50 in steps of € 0.01.

The amount of the following units can be set between € 0.05 and € 4.50 in steps of € 0.01.

The indication or input of the amounts of money is in €.

The minimum amount (first unit) and the amount of the following units can be set separately. Both settings are completely independent from each other.



Open phone casing and take out cash box!

Empty cash box!

(Handset must be on-hook!)

Settings



Confirm

PIN ????



Enter PIN (4 digits)

PIN ****

Information



Enter digits 03

Minimum/ unit



Confirm setting

Minimum 00.15 €

Setting the various cash functions



Enter amounts in steps of € 0.05
(e.g. 0 0 5 0)

Minimum 00.50 €



Confirm setting

Unit 00.15 €



Enter amounts in steps of € 0.05
(e.g. 0 0 4 0)

Unit 00.40 €



Confirm setting

Exit function



Exit this function or settings program

Exit settings



Confirm setting

Del. meter? no



Change setting no / yes

Del. meter? yes



Confirm setting
Empty cash box!
Put cash box back into the phone!



Telephone settings

List of barred call numbers

The current level of the following table contains the first digits of call numbers that are partly connected with high fees or no transmission of metering pulses takes place.

Germany

Following call numbers (including operator call 118) are barred to protect you from possible financial losses:

Call number	Call number	Call number	Call number	Call number
000...	012...	0200...	0091...	00382...
0010...	013...	0300...	0092...	00383...
002...	014...	0400...	0093...	00384...
005...	0164...	0500...	0094...	00388...
006...	0165...	0900...	0095...	00424...
007...	0166...	0901...	0096...	00425...
008...	0167...	0902...	0097...	00426...
0087...	0168...	0903...	0098...	00427...
00881...	0169...	0904...	0099...	00428...
00882...	018...	0905...	00374...	00429...
011...	019...	118...	00379...	

Austria

Following call numbers are barred to protect you from possible financial losses. If the call numbers listed below do not give you sufficient protection, you have to program additional call numbers manually.

Call number	Call number	Call number	Call number	Call number
10...	000...			

Luxembourg

Following call numbers are barred to protect you from possible financial losses. If the call numbers listed below do not give you sufficient protection, you have to program additional call numbers manually.

Call number	Call number	Call number	Call number	Call number
0010...	115...	000...		

Telephone settings

If you enable a call number which was barred according to factory preset, the FMN S5000 will accept this change from the technical point of view, but you need to bear in mind that as a result you may suffer from possible financial or other losses. Please read the information on the pages 37, 38 and 41 before you make any changes.

You want to conduct a call

- Lift the handset and wait until "Minimum x.xx €" appears in the display.
- Insert coins until the displayed minimum amount stops blinking.
- When you can hear the dial tone, dial the number. The dialled call number appears in the display.
- The FMN S5000 returns the unused coins when hanging up the handset.

Visual and acoustical request to insert more coins

If there is not enough money left to continue the call, your credit will start blinking in the display. The time (in minutes and seconds) remaining is shown on the left side of the display (starting from the second unit).

Besides, 4 short tones can be heard in the handset

You have to insert more coins to continue the call.

Using the credit for another call if the previous was unsuccessful

If the party you have called does not answer the phone or is busy, the inserted coins can be used for another call.

- hang up the handset (not longer than 1.5 seconds)
- await dial tone
- dial call number

If the handset is on-hook for more than 1.5 seconds, it will not be possible anymore to use the credit for another call.

Last number redial

If the party you have called is busy, it is possible to redial the call number automatically:

- hang up the handset (not longer than 1.5 seconds)
- await dial tone
- press  (the call number will be dialled automatically)

If the handset is on-hook for more than 1.5 seconds, it will not be possible anymore to use the last number redial feature via the  key.

Telephone settings

Using the remaining credit for another call if the previous was successful

If there is sufficient credit left after your call, you can use the credit for another call:

- hang up the handset (not longer than 1.5 seconds)
- await dial tone
- dial call number

If the handset is on-hook for more than 1.5 seconds, it will not be possible anymore to use the remaining credit for another call.

Fast dialling

If there is a certain call number on your FMN S5000 that is dialled quite frequently, e.g. "taxi", there is a way to make dialling more convenient for the user:

You can store this call number on the key located on the bottom left side of the keypad, the fast dialling key.

Following modes can be programmed for fast dialling:

- "normal" You have to insert **coins** in order to be able to dial this call number. The coins will be cashed as usual (like in a normal call).
- "coinfree" You **need not to insert coins** in order to be able to dial this call number. If the call is subject to charge (the FMN S5000 has received metering pulses from the network), the **charges will appear on your telephone bill**.

The preprogrammed fast dialling number (max. 20 digits) is automatically dialled when the handset is lifted and the fast dialling key is pressed (located on the bottom left side of the keypad; it can be labelled with one of the stickers supplied).

Note:

Do not program call numbers as fast dialling numbers which are barred in the factory preset (see page 27).

With the following procedure, you can enter, change or delete fast dialling numbers and their charges.



Open phone casing and take out cash box!

Empty cash box!

(Handset must be on-hook!)

Settings



Confirm

PIN ?????





Enter PIN (4 digits)

PIN ****

Information



Telephone settings

	Enter digits 08	Numbers
<input checked="" type="radio"/>	Confirm setting	Fast dial
<input checked="" type="radio"/>	Confirm setting	Fast dial off
<input type="checkbox"/>	Change setting off / on	Fast dial on
<input checked="" type="radio"/>	Confirm setting	F. dial coinfree
<input type="checkbox"/>	Select coinfree / normal	F. dial normal
<input checked="" type="radio"/>	Confirm setting
	Enter fast dialling number	023456789.....
<input checked="" type="radio"/>	Confirm setting	Exit function
<input type="checkbox"/>	Exit this function or settings program	Exit settings
<input checked="" type="radio"/>	Confirm setting	Del. meter? no
<input type="checkbox"/>	Change setting no / yes	Del. meter? yes
<input checked="" type="radio"/>	Confirm setting	
	Empty cash box!	
	Put cash box back into the phone!	

If you intend to program the fast dialling key with a fast dialling number, you can label it with one of the stickers provided. Furthermore, there are stickers that are not labelled. For labelling these stickers, we recommend to use a pen which is non-fading, wipe- and waterproof.

Setting the dialling method

The FMN S5000 can be operated in two different dialling methods. These are tone dialling (DTMF) and pulse dialling. The setting depends on the dialling method your telephone line supports.

	Open phone casing and take out cash box!	Empty cash box!
	(Handset must be on-hook!)	Settings
<input checked="" type="radio"/>	Confirm	PIN ????
	Enter PIN (4 digits)	PIN ****
		Information
	Enter digits 04	Dialling

Telephone settings



<input checked="" type="checkbox"/>	Confirm setting	Dialling DTMF
<input type="checkbox"/>	Change dialling method DTMF / Pulse	Dialling pulse
<input checked="" type="checkbox"/>	Confirm setting	Exit function
<input type="checkbox"/>	Exit this function or settings program	Exit settings
<input checked="" type="checkbox"/>	Confirm setting	Del. meter? no
<input type="checkbox"/>	Change setting no / yes	Del. meter? yes
<input checked="" type="checkbox"/>	Confirm setting Empty cash box! Put cash box back into the phone!	

Automatic public line access

The FMN S5000 can be programmed to dial a trunk code before the call number is dialled. It can either be done automatically or when the handset is lifted, depending on the setting. This function is important if you want to make calls within different telephone networks or operate the payphone on a PABX.



Open phone casing and take out cash box!

		Empty cash box!
	(Handset must be on-hook!)	Settings
<input checked="" type="checkbox"/>	Confirm	PIN ????
	Enter PIN (4 digits)	PIN ****
		Information
	Enter digits 06	Line access
<input checked="" type="checkbox"/>	Confirm setting	Line access off
<input type="checkbox"/>	Change setting off / on	Line access on
<input checked="" type="checkbox"/>	Confirm setting	Flash off
<input type="checkbox"/>	Change setting off / on	Flash on
<input checked="" type="checkbox"/>	Confirm setting	Flash 100 ms
<input type="checkbox"/>	Enter Flash time, 1/100 s (e.g. 15)	Flash 150 ms
<input checked="" type="checkbox"/>	Confirm setting	Tr.c.....

Telephone settings



Enter trunk code, optional (e.g. 0)

0.....



Enter dial pause, optional
(keep the key pressed for longer than 1.5 s)

0P.....



Enter further drunk codes,
max.10 digits (e.g. 555)

0P555.....



Confirm setting

Exit function



Exit this function or settings program

Exit settings



Confirm setting

Del. meter? no



Change setting no / yes

Del. meter? yes



Confirm setting
Empty cash box!
Put cash box back into the phone!



Certain PABXs use the flash for signalling.
Please see the user manual of your PABX for setting the flash and necessary dial pauses.

Telephone settings

Display messages

Minimum 0.15 €

Explanations

Displays the minimum amount to be inserted (blinking) when the handset is off-hook.

1st unit free

Amount for the first unit (minimum) is set to € 0.00.

Coinfree

No coins need to be inserted in order to be able to make this call.

Credit 0.10 €

Credit (stops blinking when it reaches its minimum amount).

Coin barred

Inserted coin is barred.

0123456789012345

Display of dialled call number.

number barred

Dialled call number is barred.

12:30 0.60 €

Display of the time remaining (starting from the second unit.)
Display of the credit.

00:08 0.05 €

Display of time remaining (starting from the second unit) and display of credit (blinking) to request more money.

Disconnect

The call is automatically disconnected when credits are exhausted.

Please hang up

Appears after automatic disconnect or when the handset is off-hook for more than 60 seconds without using the phone.

Incoming call

Incoming call.

Emerg. calls only

Cash box is full or coin mech is out of order.

Out of order

Phone is out of order.

Settings for incoming calls

Activating / deactivating incoming call acceptance

If you do not want the FMN S5000 to accept incoming calls, you can deactivate the feature "Incoming call acceptance".

Afterwards, the FMN S5000 cannot take incoming calls anymore. The call signal, however, is still ringing with every incoming call (second bell). Additionally, the ringer can be deactivated via the feature "Ringer off".











In that case, we advise not to fill in the labelling card or exchange it entirely (see page 10).

Electronic ringer

You can set the volume of the call signal / ringer in 10 levels.

The volume of the call signal is a bit lower than with normal telephones because the openings of the phone are designed to be as small as possible in order to avoid manipulations by forcibly inserting objects.

It is also possible to deactivate the ringer. To activate or deactivate incoming call acceptance, the ringer as well as the ringer volume, proceed as follows:

	Open phone casing and take out cash box!	Empty cash box!
	(Handset must be on-hook!)	Settings
	Confirm	PIN ????
	Enter PIN (4 digits)	PIN ****
		Information
	Enter digits 05	Incoming call
	Confirm setting	Inc. call off
	Change setting off / on	Inc. call on
	Confirm setting	Ringer off
	Change setting off / on	Ringer on
	Confirm setting	Ring.handset off
	Change setting off / on	Ring.handset on
	- the ringer can be emitted additionally by the handset, this option can be activated here	
	Confirm setting	Ringer volume 1

Settings for incoming calls



Set ringer volume (e.g. level 6)
0: volume off; 9: maximum volume

Ringer volume 6



Confirm setting

Exit function



Exit this function or settings program

Exit settings



Confirm setting

Del. meter? no



Change setting no / yes

Del. meter? yes



Confirm setting
Empty cash box!
Put cash box back into the phone!

ID tone (Payphone Recognition Tone)

When the FMN S5000 receives an incoming call, it sends out an ID tone (Payphone Recognition Tone) for several times after lifting the handset (can be heard in the handset). This identifies your telephone as a payphone and thus, connections via operator (e. g. collect calls) can be prevented.

The ID tone can be deactivated via the service program only.

After that, your FMN S5000 cannot be identified as a coin-operated telephone anymore.

For your own protection, do not deactivate the ID tone.

Open the phone casing!

Press the service key (red)
(see description on page 50)
(Handset must be on-hook!)

Service program



Confirm

PIN ????



Enter PIN (4 digits)

PIN ****



Enter digits 05

Information



Confirm setting

Incoming call



Confirm setting

Inc. call on



Change setting on / off

ID tone on



Confirm setting

ID tone off



Confirm setting

Ringer on

Ring.handset on

Settings for incoming calls

- | | | |
|-------------------------------------|--|-----------------|
| <input checked="" type="checkbox"/> | Confirm setting | Ringer volume 9 |
| <input checked="" type="checkbox"/> | Confirm setting | Exit function |
| <input type="checkbox"/> | Exit this function or settings program | Exit settings |
| <input checked="" type="checkbox"/> | Confirm setting | |

Lock phone casing!

Information

On page 7 (factory preset) as well as on page 27, we informed you that certain call numbers are already programmed with no or special charges.

Following settings are possible with the FMN S5000:

- to assign further call numbers with no or special charges
- to change or delete the charges for each programmed call number
- to bar call numbers or not.

For explanations of the various call numbers with no or special charges, see below:

- **Call number is barred**
Dialling this call number is **not possible**.
- **Call number is coinfree (insertion of coins is not required)**
You need **not to insert coins** to dial this call number. If the call is subject to charge, the charges will appear on your telephone bill.
- **Call number area is coinfree (insertion of coins is not required)**
You need **not to insert coins** to dial call numbers from this call number area (e.g. call numbers starting with particular digits). If the call is subject to charge, the charges will appear on your telephone bill.
- **Call number is tollfree**
You must insert the requested **minimum amount**. The amount will be returned if the call is tollfree. If the call is subject to charge, the amount will be cashed by the phone.
- **Call number is enabled (which was barred before)**
You can dial a call number which was barred before. Before enabling this call number, please inform yourself about the charges connected with this number.
- **Call number area with normal tariffing**
Dialling this number replaces all special tariffs that were eventually fixed before (except barred call numbers, coinfree call numbers or coinfree call number areas) by setting it back to the tariff adjusted to the minimum amount and unit. Additionally, the input of a time limitation for the arrival of the tariff information is possible. Therewith, a calculated suppression of separated pulses (tariff information which leads to disconnection of the call because the credit is not sufficient and which is therefore not settled) can be reached. This form of tariffing can also be used for "all numbers", so that, with the beginning of dialling any call number, the fixed time for the arrival of the second tariff information is taken as a basis. If the credit is not sufficient after the end of the given time limit, an early interruption of the call will take place. The following fixed special tariffings superscribe this option.

Call numbers with special charges

- **Call number with one single charge**

When dialling this number, the phone cashes the preset minimum amount at the beginning of the call only. The actual costs of the call, however, will appear on your bill.

- **Call number / call number area with normal self tariffing**

Instead of charging via 16 (12) kHz metering pulse, it is possible to charge several call numbers or call number areas via self tariffing which is initiated by the FMN S5000 itself. The time between the first and the second self tariffing pulse and the subsequent self tariffing pulses can be set independently.

The time can be set between 1 and 360 seconds. The coins are cashed approx. 30 seconds after starting the dialling procedure, whereby it is not relevant whether the call was successful or not. As soon as the coins are cashed, the phone automatically activates the microphone.

Note: If the subscriber you have called answers the call before the preset time of 30 seconds, you can activate the microphone by pressing the number redial key . In this case, the minimum amount is cashed immediately.

- **Call number with extended self tariffing**

Extended self tariffing is similar to normal self tariffing. Additionally, you can set the minimum amount and the subsequent amount separately.

If you program call numbers with special charges, there may be differences between the actual takings of the phone and the telephone bill you will receive.

These variations are left to your own discretion and should be considered by you carefully. No responsibility for disadvantageous settings is taken by the producer.

You can store a minimum of 100 call numbers with special charges (max. 20 digits). (We advise you to take detailed notes of the settings made by you).

You can make changes via the following procedure:



Open phone casing and take out cash box!

Empty cash box!

(Handset must be on-hook!)

Settings



Confirm

PIN ?????



Enter PIN (4 digits)

PIN ****



Enter digits 08

Information

Numbers



Confirm setting

Fast dial



Scroll to







Special numbers





Confirm setting

Search

Call numbers with special charges

<input type="checkbox"/>	Select Search / Entry	Entry
<input checked="" type="radio"/>	Confirm setting
	Enter call number	0234506789.....
<input checked="" type="radio"/>	Confirm setting	Delete?
<input type="checkbox"/>	Scroll to	Bar number
<input type="checkbox"/>	Scroll to	Number coinfree
<input checked="" type="radio"/>	Confirm setting	Search
<input type="checkbox"/>	Select Search / Entry	Entry
<input checked="" type="radio"/>	Confirm setting
	Enter call number	63217.....
<input checked="" type="radio"/>	Confirm setting	Delete?
<input type="checkbox"/>	Scroll to	Bar number
<input type="checkbox"/>	Scroll to	Number coinfree
<input type="checkbox"/>	Scroll through further settings	
	⋮	
<input type="checkbox"/>	Scroll to	Ext. self tariff
<input checked="" type="radio"/>	Confirm setting	Minimum 00.00 €
	Enter minimum amount (e.g. 00 10)	Minimum 00.10 €
<input checked="" type="radio"/>	Confirm setting	Time M 00:00,00
	Enter time (e.g. 10 s)	Time M 00:10,00
<input checked="" type="radio"/>	Confirm setting	Unit 00.00 €
	Enter Unit (e.g. 00 15 €)	Unit 00.15 €
<input checked="" type="radio"/>	Confirm setting	Time E 00:00,00
	Enter time (e.g. 20 s)	Time E 00:20,00
<input checked="" type="radio"/>	Confirm setting	Search
<input type="checkbox"/>	Select Search / Entry	Entry
<input checked="" type="radio"/>	Confirm setting
	Enter call number	6321754.....

Call numbers with special charges

<input checked="" type="checkbox"/>	Confirm setting	Delete?
<input type="checkbox"/>	Scroll to	Bar number
<input type="checkbox"/>	Scroll to	Number coinfree
<input type="checkbox"/>	Scroll through further settings	
	⋮	
<input type="checkbox"/>	Scroll to	Normal tariff
<input checked="" type="checkbox"/>	Confirm setting	Time M 00:00,00
	Enter time (e.g. 10 s)	Time M 00:10,00
<input checked="" type="checkbox"/>	Confirm setting	Search
<input type="checkbox"/>	Select Search / Entry	Entry
<input checked="" type="checkbox"/>	Confirm setting
<input type="checkbox"/>	Scroll to	All numbers
<input checked="" type="checkbox"/>	Confirm setting	Delete?
<input type="checkbox"/>	Scroll to	Normal tariff
<input checked="" type="checkbox"/>	Confirm setting	Time M 00:00,00
	Enter time (e.g. 10 s)	Time M 00:10,00
<input checked="" type="checkbox"/>	Confirm setting	Search
<input type="checkbox"/>	Select Search / Entry	Entry
<input type="checkbox"/>	Select Entry or exit this function	Exit function
<input type="checkbox"/>	Exit this function or settings program	Exit settings
<input checked="" type="checkbox"/>	Confirm setting	Del. meter? no
<input type="checkbox"/>	Change setting no / yes	Del. meter? yes
<input checked="" type="checkbox"/>	Confirm setting	
	Empty cash box!	
	Put cash box back into the phone!	

Call numbers with special charges

Important notes:

If you want to enter call numbers which are already programmed in the phone by default, the entered number will start blinking in the display. When entering or changing the settings (e.g. amount or time), you have to move the cursor to the value you want to change via the fast dialling key and enter the requested value via the keypad.

All call numbers programmed with no or special charges can be viewed any time via the menu "Special numbers" (see page 13).

The FMN S5000 is also prepared to handle call numbers with other special charges such as:

- **call numbers with secure tariff**
- **call numbers with secure minimum**
- **call numbers with absolute special tariff.**

Please do not change these settings.

Call numbers with block tariffing

Most of the telephone calls are charged via the 16 (12) kHz metering pulse and with each metering pulse, first the minimum amount and then the following units are cashed.

Block tariffing, however, means that both, at the beginning and during the call, several tariff units will be charged at the same time.

If a call number with block tariffing which is not listed in the paragraph "Default settings" on page 7 is dialled out from the FMN S5000 for the first time, the following will happen in case the minimum amount of a normal call was inserted:

- The call will be disconnected automatically when the first group of metering pulses has been received.
- The phone calculates the new minimum amount based on the metering pulses received.
- Afterwards, the previously dialled number appears in the display for a short period of time.
- Afterwards, the new minimum amount appears in the display.
- The amount of money inserted before is automatically credited and displayed if you did not hang up the handset.
- In case you replaced the handset, the amount of money inserted is cashed by the phone; it could be possible, however, that the amount of money cashed by the phone is less than the actual charges of the call.
- If you insert as many coins as required for the minimum amount, the phone dials the call number again.

The FMN S5000 automatically saves the entire call number area of this call number with block tariffing, e.g. the phone assumes that all call numbers starting with these particular digits are charged with block tariffing.

Call numbers with special charges

In the future, all further calls starting with this call number area will be charged with block tariffing. The advantage of this procedure is that you do not need to change the settings yourself.

See pages 41, 42 and 43 for further information on preset call number areas with block tariffing.

The FMN S5000 is also prepared to handle call numbers with other block tariffs such as:

- **call numbers with cyclic block tariffing**
- **call numbers with normal block tariffing**

Please do not change these settings. Call number areas with block tariffing are automatically detected by the phone (see pages 41, 42 and 43).

Automatic detection of call number areas with block tariffing

For further information on automatically detected call number areas with block tariffing, use the following procedure. This is also applicable if you want to delete call number areas which are not charged with block tariffing anymore.



Open phone casing and take out cash box!

Empty cash box!

(Handset must be on-hook!)

Settings



Confirm

PIN ????



Enter PIN (4 digits)

PIN ****



Enter digits 08

Information



Confirm setting

Numbers



Scroll to

Fast dial



Scroll to

Special numbers



Confirm setting

Block tariff #

Erase table!

a)



Confirm setting

Delete? no



Scroll to

Delete? yes



Confirm setting

Exit function

- By confirming this setting, the entire table will be deleted.
- This feature may only be used if the payphone should detect all call number areas with block tariffing anew; since the reset to default settings is not possible, we recommend to delete each call number with block tariffing separately.

Call numbers with special charges

b)

- | | | |
|-------------------------------------|--|-----------------------|
| <input type="checkbox"/> | Scroll to | Search |
| <input checked="" type="checkbox"/> | Confirm setting | |
| <input checked="" type="checkbox"/> | Confirm setting | All numbers |
| <input checked="" type="checkbox"/> | Confirm setting | 0150 |
| <input type="checkbox"/> | Scroll to | 0151 |
| <input type="checkbox"/> | Scroll through further settings | |
| | ⋮ | |
| <input type="checkbox"/> | Scroll to | 0041 |
| <input checked="" type="checkbox"/> | Confirm setting | Delete? |
| <input type="checkbox"/> | Scroll to | 0041 |
| <input checked="" type="checkbox"/> | Confirm setting | Pulses 1 4 |
| <input checked="" type="checkbox"/> | Confirm setting | Time M 01:00,00 |
| <input checked="" type="checkbox"/> | Confirm setting | Pulses 2 4 |
| <input checked="" type="checkbox"/> | Confirm setting | Search |
| <input checked="" type="checkbox"/> | Confirm setting | |
| <input checked="" type="checkbox"/> | Confirm setting | All numbers |
| <input checked="" type="checkbox"/> | Confirm setting | 0150 |
| <input type="checkbox"/> | Scroll to | 0151 |
| <input checked="" type="checkbox"/> | Confirm setting | Delete? |
| <input checked="" type="checkbox"/> | Confirm setting | Search |
| <input type="checkbox"/> | Select Entry or exit this function | Exit function |
| <input type="checkbox"/> | Exit this function or settings program | Exit settings |
| <input checked="" type="checkbox"/> | Confirm setting | Del. meter? no |
| <input type="checkbox"/> | Change setting no / yes | Del. meter? yes |
| <input checked="" type="checkbox"/> | Confirm setting | |
| | Empty cash box! | |

Device-specific settings

Important note:





Automatic detection of call numbers with block tariffing activated in your payphone is not necessarily supported by the block tariffing sent by the telephone network. If your network operator does not support block tariffing, you may encounter problems with call number areas where the 16 (12) kHz metering pulse is sent in a pulse rate < 1 s. In order to avoid such problems, it is necessary to bar these call number areas.

Setting your individual text

The FMN S5000 offers the possibility to replace the preset display message in idle condition by an own text which is tailored to your individual requirements. To activate and enter your individual display message in idle condition, proceed as follows:

The FMN S5000 is in idle condition, that means the handset is on-hook for longer than 1.5 s and the designation of the device is shown on the display.

Please take into consideration that, in case of external power feeding by a battery and the according setting in the menu "Ext. power feeding", the display is switched off in idle condition. In this case, the self defined text is only visible for two or three seconds during the change to idle condition after replacing the handset and before the display is switched off.

		FMN S5000
	Open phone casing and take out cash box!	Empty cash box!
	(Handset must be on-hook!)	Settings
	Confirm	PIN ????
	Enter PIN (4 digits)	PIN ****
		Information
	Enter digits 16	Own text
	Confirm setting	Text off

An existing individual text can be activated or deactivated. In case of activating, the given text is taken over to the display in idle condition (an empty description field appears as empty display). The deactivation of the given text leads to the preset indication of the designation of the device.

Device-specific settings

<input type="checkbox"/>	Change setting on / off	Text on												
<input checked="" type="radio"/>	Confirm setting													
<table border="1"><tr><td>1</td><td>2</td><td>3</td></tr><tr><td>4</td><td>5</td><td>6</td></tr><tr><td>7</td><td>8</td><td>9</td></tr><tr><td>*</td><td>0</td><td>#</td></tr></table>	1	2	3	4	5	6	7	8	9	*	0	#	For inputting the text, a specific editor is used which is described in the following	ABCDefgh
1	2	3												
4	5	6												
7	8	9												
*	0	#												
<input checked="" type="radio"/>	Confirm setting	Exit function												
<input type="checkbox"/>	Exit this function or settings program	Exit settings												
<input checked="" type="radio"/>	Confirm setting	Del. meter? no												
<input type="checkbox"/>	Change setting no / yes	Del. meter? yes												
<input checked="" type="radio"/>	Confirm setting	Please wait!												
	Empty cash box! Put cash box back into the phone!													
	After leaving the settings program, you can see your own message in the display in idle condition.	ABCDefgh												

The text editor

To make the editing transaction as easy as possible and to manage it with as few steps as possible, all available letters, digits and symbols that can be entered for the text are stored on the keys 1 to 4.

The editing procedure consists of 3 steps:

1. Choose the position in the display where you want to enter the text.
2. Press the relevant key (from 1 to 4) which contains the letter, digit or symbol which you want to enter.
3. Scroll through the letters, digits or symbols via the keys 7 and 8.

Repeat this procedure until you have entered your complete text.

The keys listed below have the following functions:

<input type="checkbox"/>	<input type="checkbox"/>	<input type="checkbox"/>	<input type="checkbox"/>	- contain the available letters , digits or symbols that can be entered
<input type="checkbox"/>	<input type="checkbox"/>	<input type="checkbox"/>	<input type="checkbox"/>	- to scroll downwards to get the required letter / digit / symbol
<input type="checkbox"/>	<input type="checkbox"/>	<input type="checkbox"/>	<input type="checkbox"/>	- to scroll upwards to get the required letter / digit / symbol
<input type="checkbox"/>	<input type="checkbox"/>	<input type="checkbox"/>	<input type="checkbox"/>	- to move the cursor one position downwards / to confirm the selected letter / digit / symbol
<input type="checkbox"/>	<input type="checkbox"/>	<input type="checkbox"/>	<input type="checkbox"/>	- to move the cursor one position upwards / to confirm the selected letter / digit / symbol

Device-specific settings

- Explanation of the keys 1 to 4

- 1** - all capital letters from A Z
- 2** - all small letters from a z
- 3** - all digits from 0 9
- 4** - all special symbols [space], ä ö ü ß ! " # \$ % & () * +, . / ; : ; < = > ?

Graphical overview of an editing procedure

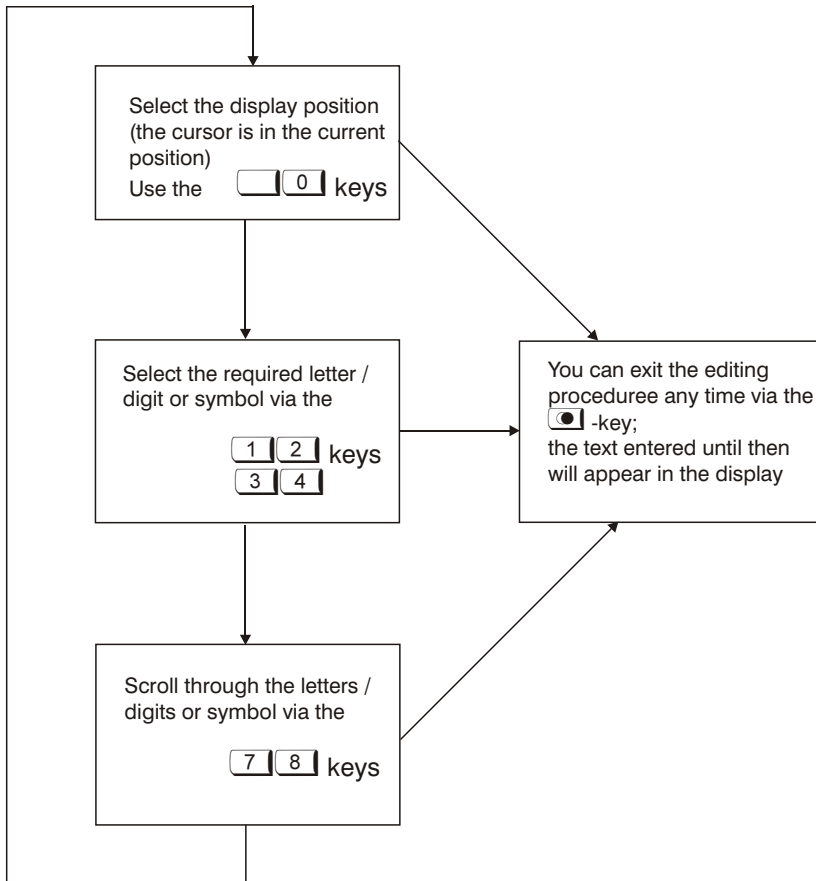

Device-specific settings

Settings for external power feeding

In case of normal operation, the FMN S5000 is supplied externally by the wall power supply. In this mode of operation, there is enough energy available to show a display message in idle condition (handset on-hook). Should it get necessary for lack of a network access near the FMN S5000 to realise the external power supply by a battery, a considerate dealing with the resources has to be ensured by separating the FMN S5000 from the supply unit during the transition to the idle condition. To differentiate between the cases of operation, the form of the external power feeding has to be set in the settings program.



Open phone casing and take out cash box!

Empty cash box!

(Handset must be on-hook!)

Settings



Confirm

PIN ????



Enter PIN (4 digits)

PIN ****



Enter digits 15

Information

Ext.supply



Confirm setting

Supply Net



Change setting off / on

Supply Bat.



Confirm setting

Exit function



Exit this function or settings program

Exit settings



Confirm setting

Del. meter? no



Change setting no / yes

Del. meter? yes



Confirm setting

Please wait!

Empty cash box!

Put cash box back into phone casing!

Technical data

- Wall-mounted telephone
- Robust metal casing
- Robust metal keypad
- Handset with armoured metal handset cord
- Dimensions: height 450 mm, width 274 mm, depth 170 mm
- Dimensions incl. external cash box: height 684 mm, width 274 mm, depth 170 mm
- Weight with full internal cash box: approx. 12 kg
- Weight with full external cash box: approx. 22 kg
- Electronic coin validation
- Accepts the following coins: € 0.05, € 0.10, € 0.20, € 0.50, € 1 and € 2
- Capacity of internal cash box: approx. 900 pieces of € 0.05 coins
- Capacity of external cash box: approx. 1400 pieces of € 0.05 coins
- Power supply: voltage 230 V + 6 % -10 %; 50 Hz; 12.8 mA; 2.9 VA
- Dialling method: DTMF (tone dialling) / pulse dialling
- Charging: via 16 (12) kHz metering pulse or self tariffing
- Operating temperature range: -25°C up to +50°C
- Enclosure: IP 20

Connection permit

Herewith, the FMN communications GmbH Nordhausen declares that the FMN S5000 complies with the basic requirements and the other relevant provisions of the directive 1999/5/EG (R&TT directive).

The complete declaration of conformity can be found and downloaded on our website <http://www.fmncom.com>.

The FMN S5000 is designed for connection to analogue telephone lines with 16 (12) kHz metering pulse (analogue access with standard requirements) of the public telecommunications network. It may be connected and operated by any person.

The FMN S5000 is compliant with the harmonized standards for connection to public telecommunications networks.

This is no guarantee for successful operation of the telephone unit on each network termination point due to the differences in the public telecommunications network between the different countries.

For operating problems, contact your specialist dealer.

Procedure in case of malfunction

The first thing you have to do in case of malfunction is to empty the cash box. The display message "Emerg. calls only" can mean the following.

- cash box is full
or
- coin mech / validation is out of order
or
- gold cap (power supply) has no power
(Leave the handset in off-hook position for several minutes.)

Contact your specialist dealer if you have still problems with the FMN S5000 after you have emptied the cash box.

Attention:

If the following display messages appear in the display when entering the settings program

CRC Konf. Error

CRC No. Error

CRC Prime Error

EEPROM defect

the settings program will be aborted automatically.

After that, the following messages may appear in the display requesting to load the copy or default values:

Load Conf. Copy

Load Conf. Def.

Load No. Def.

Load Prime Copy

Load Prime Def.

If you want to load the copy or default values, confirm by pressing the  key.

Cleaning

To clean the FMN S5000, use a damp or antistatic cloth. Do not use any abrasive cleaning agents.

Instructions for using the self test

The self test is part of the service program and serves for a better localisation of malfunction and their remedy. The self test cannot be used when the following malfunctions occur:

- controller is out of order (IC)
- no or insufficient power supply
- keypad error
- LCD / display error

How to execute the self test:

Unlock / open the phone casing!

Press the service key (red) (see drawing below)

Service program

(Handset must be on-hook!)



Confirm

PIN ????

Enter PIN (4 digits)

PIN ****



Enter digits 14

Information



Confirm setting

Self test

several modules of the FMN S5000 are tested (takes approx. 1 min)
(actuated keys are displayed during the keypad test)

LCD-Test

End of self test

Self test

3 x  Confirm or digits 17

Exit program



Confirm setting

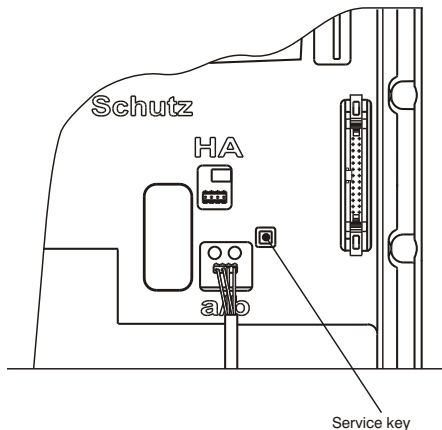

Troubleshooting

Many errors can be identified with the self test in the service program:

Error message	Cause	Remedy
Indefinable display	Display is out of order	Contact your specialist dealer
Key x is fixed!	Key is defective or fixed or cannot be pressed anymore	Check if the key is fixed or defective
CRC conf. error	Error in configuration	Load copy or default values *)
CRC No. error	Error in lists of programmed numbers (black list, white list etc.)	Load default values *)
CRC Prime error	Error in prime configuration	Load copy or default values *)
Line error	Analogue public line is not working properly	Check the line / connection
Gold-Cap error	Gold-Cap insufficiently loaded	Exit the service program, lift the handset approx. 5 min., replace the handset and start self test again
No response	Coin mech / validation is out of order "Emerg. calls only"	Contact your specialist dealer
G Cap U low	Gold Cap has not enough power	Exit the service program, lift the handset approx. 5 min., replace the handset and start self test again
Coin insertion defective	Coin insertion unit / channel is blocked / out of order	Check whether there is anything stuck in the coin channel / insertion unit
CP x covered	Coins or anything else got stuck in the channel	Contact your specialist dealer
Restoration defective	Restoration is not possible	Contact your specialist dealer
Cash box full	Cash box is full > 80 %	Empty cash box and delete the meter / counter
Unknown error	Not defined error	Contact your specialist dealer
Coins in MS 2A	Coin jam in the coin mech / validation	Contact your specialist dealer

Monitoring

*) For loading the copy or default values, following messages may appear in the display:

Load Conf. Copy

Load Conf. Def.

Load No. Def.

Load Prime Copy

Load Prime Def.

If you want to load the copy or default values, confirm by pressing the  key.

Reporting of cash box content and system error message / remote reporting

The FMN S5000 enables remote reporting (prerequisite: the phone receives an incoming call and incoming call acceptance is deactivated) of the cash box content and system error messages of the following modules:

- coin mech / validator MS2A
- keypad
- metering pulse module
- EEPROM
- display
- in case no metering pulses are available
- in case of no power.

Remote reporting is activated after a programmable amount of dial tones (1... 15). Remote reporting is only possible when incoming call acceptance is deactivated. You can choose between acoustic remote reporting and remote reporting via DTMF dialling:

a) Acoustic remote reporting

1) Procedure:

- When the FMN S5000 is called, it sends the following tones after the preprogrammed amount of dial tones have been received:
200 ms tone (approx. 830 Hz) → 200 ms pause → second tone if necessary → 1.2 s pause...

or

- 1 s NF tone (approx. 830 Hz) → 1.2 s pause...
- The tone cycles are repeated 5 times.
- The hook-switch is locked during the entire procedure of remote reporting starting from the point when the FMN S5000 receives the incoming call, e.g. remote reporting cannot be interrupted and you cannot conduct calls
- When the handset is lifted during the procedure, the phone cannot be used until remote reporting is completed, replace the handset when the procedure is completed to be able to make calls as usual.

Monitoring

2) Reporting of cash box content:

- 1 tone (200 ms) means 0% to < 25% of cash box is full
- 2 tones (200 ms) 25% to < 50% of cash box is full
- 3 tones (200 ms) 50% to < 75% of cash box is full
- 4 tones (200 ms) 75% to < 100% of cash box is full

or

- 1 tone (1s) means "Emerg. calls only" is visible in the display and the cash box is full.

3) Reporting of system error message

In case there are malfunctions or problems with one or more of the modules listed above, the FMN S5000 sends out a kind of twitter tone (a tone of 4 seconds length which is alternating in steps of 100 ms).

b) Remote reporting via DTMF dialling

Remote reporting via DTMF dialling gives you a more detailed specification about the content of the transmitted message. You need, however, a suitable receiver in order to analyse the received information. Please see the user manual of your receiver for information on set-up and transmission.

Note:

If remote reporting is activated, the ringer has always to be deactivated via the settings program in order to prevent the phone from ringing.

Setting remote reporting

Remote reporting can only be activated when incoming call acceptance is deactivated (see "Activating / deactivating incoming call acceptance", on page 34).



Unlock / open the internal cash box!

Empty cash box!

(Handset must be on-hook!)

Settings



Confirm

PIN ?????



Enter PIN (4 digits)

PIN ****



Enter digits 10

Information

Rem. report



Confirm setting

Rem. report off



Change setting off / on

Rem. report on



Confirm setting

Report via DTMF



Select reporting via DTMF or tones

Report via tones



Confirm setting

Dial tones 5

Monitoring

<input type="checkbox"/>	Change setting	Dial tones 6
<input type="checkbox"/>	Change setting (1...15 dial tones)	Dial tones 7
<input type="checkbox"/>	...	Dial tones 10
<input checked="" type="checkbox"/>	Confirm setting	Exit function
<input type="checkbox"/>	Exit this function or settings program	Exit settings
<input checked="" type="checkbox"/>	Confirm setting	Del. meter? no
<input type="checkbox"/>	Change setting no / yes	Del. meter? yes
<input checked="" type="checkbox"/>	Confirm setting	
	Empty and lock cash box!	

Monitoring metering pulses / metering pulse check

To avoid a high degree of manipulation, the reception of the metering pulses is monitored in the following way:

1. Metering pulses must not be longer than 5 s during a call. If there is one metering pulses >5 s, the phone automatically disconnects the call.
2. If the phone does not receive a metering pulse within 4 minutes after a call setup, the call will be disconnected after 4 minutes.
3. If the phone does not receive metering pulses within 1 minute after call setup during a total of 5 calls (when "absent short" is set; 10 when "absent long" is set), the phone displays "No met. pulse!"
This state is displayed when you enter the settings or service program. It can be deleted after remedy of the causes.

Criteria for calls without metering pulses:

- dialling procedure has been completed
- 60 s are exceeded after dialling the last digit
- the dialled number is not coinfree (coins must be inserted).













"No met. pulse!" is displayed and can be deleted when you enter the settings or service program and the PIN as follows:

Display:	No met. pulse!
<input checked="" type="checkbox"/> Confirm	Delete? no
<input type="checkbox"/> Change setting no / yes	Delete? yes
<input checked="" type="checkbox"/> Confirm	
Service programm	or Settings

Monitoring

In the settings program, the further behaviour of the FMN S5000 can be set. If metering pulse monitoring is activated via the settings program, "Emerg. calls only" will appear in the display of the FMN S5000 if 5 calls have been made without receiving metering pulses. Thus, only emergency calls can be made. Nevertheless, the phone continues to execute the metering pulse check.

Setting metering pulse monitoring

	Unlock / open the internal cash box!	Empty cash box!
	(Handset must be on-hook!)	Settings
	Confirm	PIN ?????
	Enter PIN (4 digits)	PIN ****
		Information
	Enter digits 11	Pulse monitoring
	Confirm setting	Pulse monit. off
	Change setting off / on	Pulse monit. on
	Confirm setting	absent short
	Change setting long / short	absent long
	Confirm setting	Exit function
	Exit this function or settings program	Exit settings
	Confirm setting	Del. meter? no
	Change setting no / yes	Del. meter? yes
	Confirm setting	
	Empty and lock cash box!	
	Put cash box back into phone casing!	

Menu structure

Overview of settings:

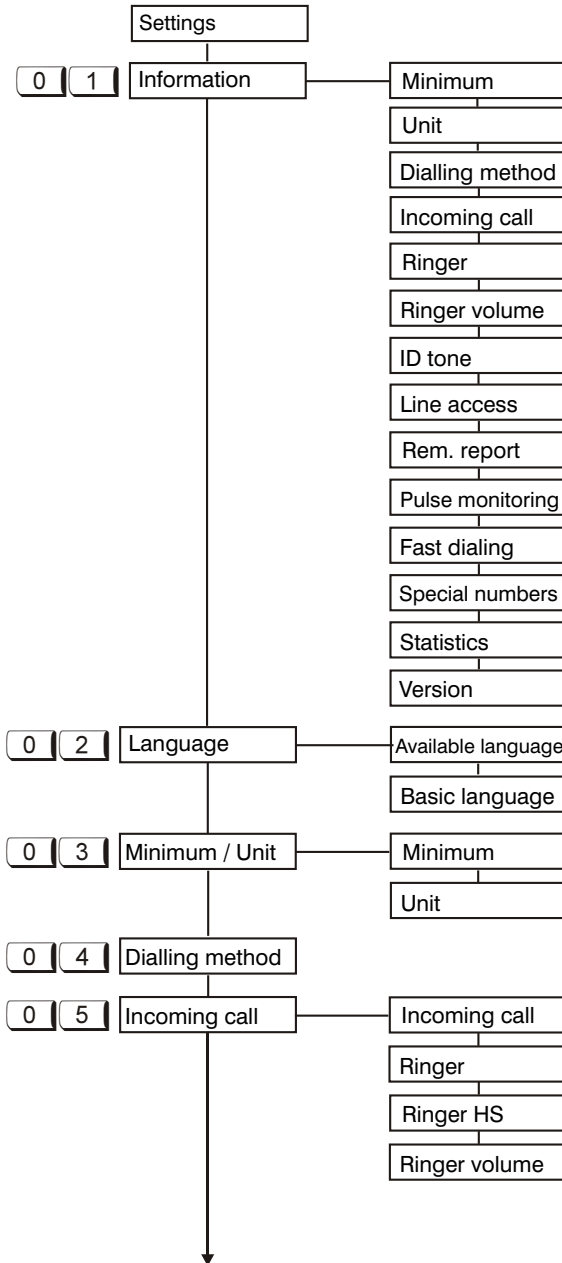

Menu structure

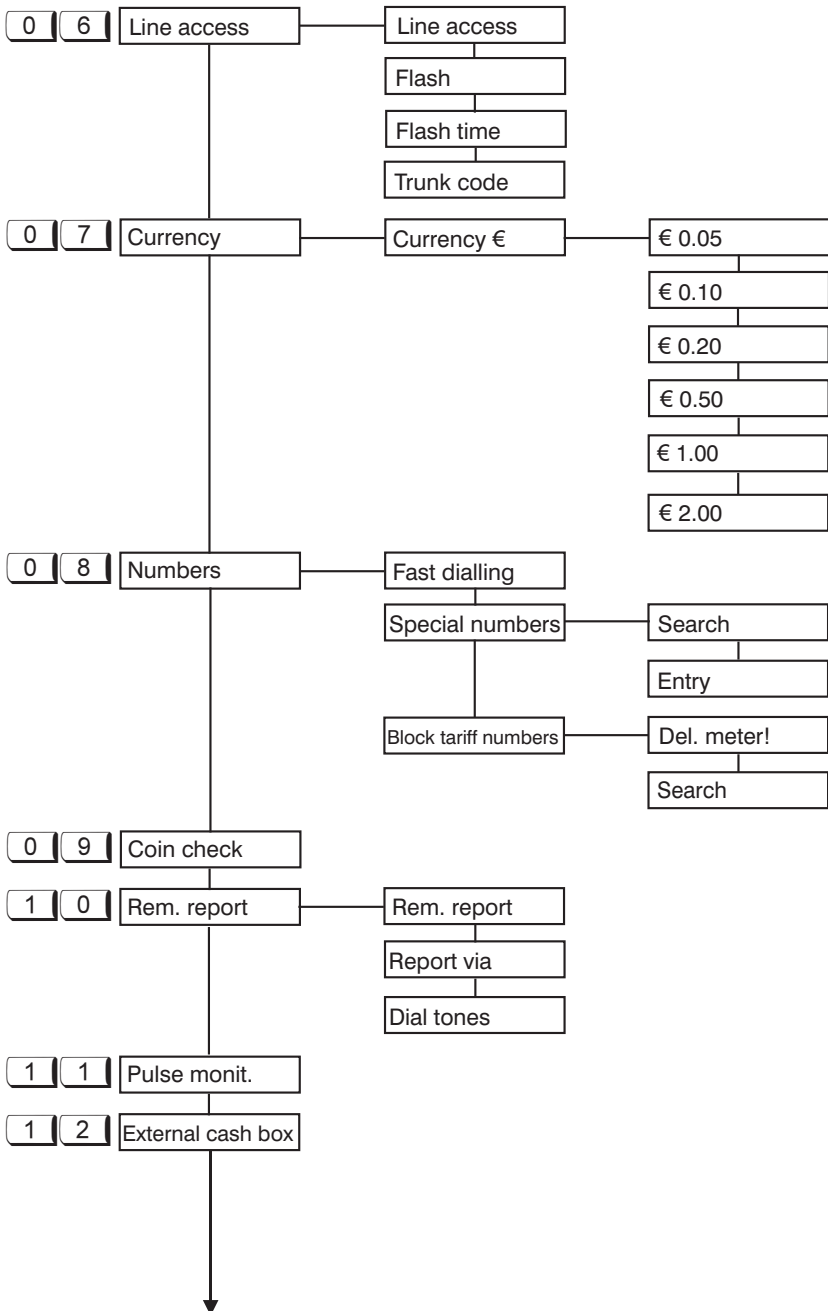

Menu structure

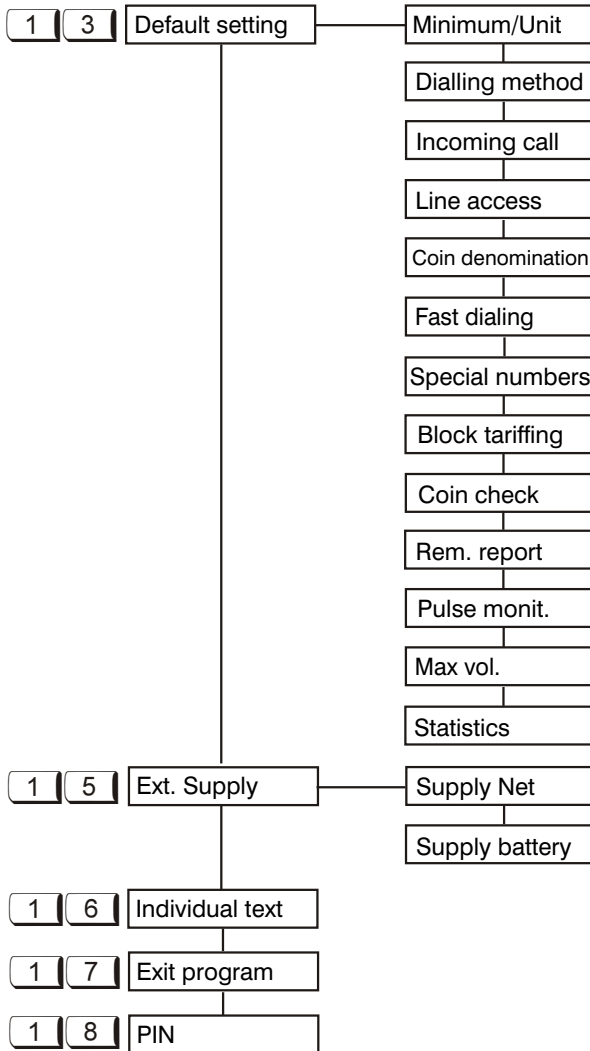

Copyright

All rights reserved.

Duplication of these instructions for use or parts thereof by any reproduction method whatsoever is not permitted without prior permission of the manufacturer.

Amendments may be published without prior notification.

Notwithstanding the above declaration, the manufacturer accepts no liability for errors in these instructions or their consequences.

For protection of the environment!

Printed on paper bleached without chlorine with a max. waste paper content of 50 %.

FMN communications GmbH

Grimmelallee 4 99734 Nordhausen

P. O. box 10 04 65 99724 Nordhausen

Phone +49 (36 31) 56-50 00

Fax +49 (36 31) 56-32 24

Email info@fmn.de

Internet www.fmncom.com

HOTLINE +49 (36 31) 56-34 16

We are at your disposal to answer your questions.

Subject to change

FMN S5000 2007.3.0610.02

Edition: No. 02/05 (1111-5156)