



## Fan-supplied Positive-pressure Breath-responsive Respirator



# User Instructions



600006 M  
May2018

## TABLE OF CONTENTS

<b>ABOUT THESE USER INSTRUCTIONS</b> .....	<b>3</b>
<b>DESCRIPTION OF THE SE400</b> .....	<b>4</b>
Main components .....	5
Features .....	5
<b>CAUTIONS AND LIMITATIONS</b> .....	<b>6</b>
<b>UNPACKING</b> .....	<b>7</b>
<b>FACEPIECE FITTING</b> .....	<b>8</b>
QNFT Procedure .....	8
<b>PREPARATION FOR USE</b> .....	<b>10</b>
Assembling the SE400 .....	10
Donning the SE400 .....	10
<b>WORKING IN A CONTAMINATED AREA</b> .....	<b>14</b>
Decontamination .....	14
<b>STORAGE AND TRANSPORT</b> .....	<b>15</b>
<b>COMPONENTS OF THE SE400</b> .....	<b>16</b>
Fan unit.....	16
Breathing hose .....	16
SE-shield breathing hose .....	16
Facepiece.....	16
Filtration media.....	17
Batteries .....	19
Battery charger (BC3) .....	22
Battery charger (BC1) .....	22
Dual battery adapter (DB1) .....	23
SE-talk speaker unit .....	23
Back pack.....	24
Waist belt.....	24
<b>SE-SHIELD PROTECTIVE ENSEMBLES</b> .....	<b>25</b>
Configurations .....	25
The SE-Shield range .....	25
<b>OPERATION</b> .....	<b>27</b>
Visible and audible warnings.....	27
Warnings label on fan unit.....	27
Warnings during start-up.....	28
Warnings during operation .....	29
Stand-by mode .....	29
Demist mode .....	30
Menu mode .....	30
Self-Test.....	30
<b>DISASSEMBLY AND REASSEMBLY</b> .....	<b>32</b>
<b>CLEANING AND MAINTENANCE</b> .....	<b>35</b>
Reconditioning after each use.....	35
Cleaning the demand valve.....	35
Replacing the visor (full facepiece) .....	38
<b>SPARE PARTS AND ACCESSORIES</b> .....	<b>39</b>
<b>TROUBLESHOOTING</b> .....	<b>40</b>
<b>OPERATION IN EXTREME CONDITIONS</b> .....	<b>41</b>
<b>SE-DATA</b> .....	<b>41</b>
<b>IMPORTANT WARRANTY INFORMATION</b> .....	<b>41</b>
<b>IN CASE OF HEAVY IMPACT</b> .....	<b>41</b>
<b>APPROVAL BODIES</b> .....	<b>42</b>

### **Warning (USA)**

Before occupational use of this respirator a written respiratory protection program must be implemented meeting all the local government requirements. In the United States employers must comply with OSHA 29 CFR 1910.134 which includes medical evaluation, training, and fit testing.

## **ABOUT THESE USER INSTRUCTIONS**

These user instructions refer to the following user instructions for components and accessories of the SE400:

- Supplementary manual – SE400 advanced functions (600007)
- SE-shield Tychem F<sup>®</sup> suits (100184-04)
- SE-shield Tyvek<sup>®</sup> and Tychem QC<sup>®</sup> suits (100325-03)
- SE-shield encapsulated suits (100292-02)
- Tychem F<sup>®</sup> Hood (100259-04)
- Breathing hose cover HC-TF (100257-03)
- Foam insert SEA-FI (100287-03)
- GBCO (600010)
- Fit test adapter FTA-400 (100288-03)
- Back pack BP2 (100267-03)
- Exhalation valve shield EVS (201540-03)
- Dual battery adapter DB1 (100273-03)

The above user instructions are supplied with the components. They are also available at The S.E.A. Group website, [www.theseagroup.com](http://www.theseagroup.com)

## DESCRIPTION OF THE SE400



The SE400 is a powered air-purifying respirator (PAPR) designed to give protection from breathing hazards. It is a high-performance PAPR known as an FPBR (Fan-supplied Positive-pressure Breath-responsive Respirator).

The SE400 has a built-in microprocessor that monitors the user's breathing pattern and adjusts the airflow to ensure continuous positive pressure in the facepiece even during high exertion.

Because the SE400 delivers breathing air only when needed, battery power and filtration media capacity are conserved.

### Positive pressure

Positive pressure increases breathing protection.

An airtight "face seal" – between the facepiece and the user's face – is critical for good respiratory protection. In practice it is very difficult to maintain a perfectly airtight face seal under all conditions. Even momentary loss of sealing can greatly reduce the level of protection.

By maintaining a slightly elevated air pressure inside the facepiece at all times, any leakage will flow outward, thus preventing inward leakage of contaminated air to the breathing zone.

A conventional PAPR delivers an essentially constant flow of breathing air to the facepiece. During high exertion the user may take very deep breaths that momentarily exceed the delivery rate of the PAPR. At these times the facepiece pressure becomes negative and inward leakage of contaminants can occur.

Because the SE400 "FPBR" is breath-responsive, continuous positive pressure can be maintained at peak inhalation airflows up to and exceeding 350 litres per minute.

Positive pressure reduces breathing resistance.

Because the air in the breathing zone is maintained at a very small positive pressure, the user feels little or no breathing resistance. By reducing the breathing effort and discomfort, he or she has more energy and awareness to do the job at hand.

The SE400 is currently available in the following models:

- **SE400AT-2** – Two-filter fan unit for industrial applications
- **SE400AT-2 Advanced** – Two-filter industrial unit with advanced functionality
- **SE46** – Three-filter fan unit for emergency response applications – includes increased peak flows, battery duration, gas filter capacity and chemical resistance; Advanced functionality; Normally fitted with Exhalation Valve Shield (EVS) and single-use Tychem F<sup>®</sup> hose cover (HC-TF)

*Note: SE400AT-2 Advanced and SE46 users should consult the supplementary manual "SE400 Advanced Functions" on the CD-ROM provided with those models.*

*Note (USA): SE400 and SE46 respirators are approved by NIOSH for use in industrial environments. They are not CBRN-approved.*

*Note: The SE400AT-2 supersedes the SE400AT. SE-Talk speaker unit and PC data cable are not interchangeable between these models.*

## Main components

A comprehensive list of components is given in section *Components of the SE400*.



1. Fan unit (SE400AT-2 shown)
2. Filtration media
3. Breathing hose
4. Facepiece
5. Demand valve
6. Battery
7. SE-Talk speaker unit
8. Back pack
9. Prefilters and prefilter holders

## Features



1. ON/OFF button
2. Status lights panel
3. Communication socket



4. Threaded connectors for filtration media
5. Threaded nuts for attachment to SE-shield protective suits



6. Warning light

## CAUTIONS AND LIMITATIONS

When using this respirator, observe the following cautions and limitations.

### Oxygen levels

- Not for use in atmospheres containing less than 19.5% oxygen.
- This respirator delivers purified ambient air. It does not generate oxygen.

### Breathing hazards

- Not for use in atmospheres immediately dangerous to life and health (IDLH) or where hazards have not been fully characterised.
- Do not exceed maximum use concentrations established by regulatory standards.
- If you sense any of the following danger signals:
  - smell or taste of contaminants
  - eye, nose or throat irritation
  - breathing difficulty
  - uncomfortably warm breathing air
  - dizziness, nausea or vomiting,immediately leave the contaminated area. Do not remove the respirator until you have reached clean air and after decontamination as required.

### Explosive atmospheres

- Contains electrical parts which may cause an ignition in flammable or explosive atmospheres. Do not use in flammable or explosive atmospheres.

### Exposure to flame

- Do not use in contact with flame. Do not use for fire fighting.

### Dermal (skin) hazards

- Use in conjunction with personal protective ensembles that provide appropriate levels of protection against dermal hazard. Failure to do so may result in personal injury even when the respirator is properly fitted, used and maintained.

### Follow these User Instructions

- Failure to properly use and maintain this respirator could result in injury or death.
- Follow these user instructions and established canister change-out schedules to ensure canisters are replaced before breakthrough occurs.
- Never substitute, modify, add or omit parts. Use only exact replacement parts in the configuration as specified by the manufacturer.

### Compliance with regulations

- (USA) All approved respirators shall be selected, fitted, used and maintained in accordance with MSHA, OSHA and other applicable regulations.
- Use replacement parts in the configuration as specified by the applicable regulations and guidance. Consult the respirator Approval Label (USA) for approved configurations.

## **S - Special or Critical User's Instructions (USA)**

### **Foam Inserts**

If Facepiece Fit Testing fails due to particular facial contours, SEA recommends that the SEA Full Face Mask Foam Insert (model number SEA-FI) be inserted into the facepiece. Please refer to the User Instructions for the foam inserts or contact an SEA Group representative for more information.

*Note: NIOSH has classified the foam inserts as a required component. However, foam inserts shall only be used in cases where a satisfactory facepiece fit cannot be achieved without them.*

## **UNPACKING**

The following parts are included with the SE400:

- Fan unit
- Breathing hose and hose latch retainer
- Facepiece with demand valve and head harness
- Waist belt
- Prefilters and prefilter holders
- SE400 user instructions
- Cleaning tissues
- Up to two (2) batteries (level of charge not assured)
- Battery charger with power supply and AC power cable
- Speaker unit
- CD-ROM containing user instructions and management software (Advanced only)
- Data cable for connection to PC (Advanced only)
- NIOSH Approval Label (USA)
- Single-use breathing hose cover (SE46 only)
- Exhalation valves shield (SE46 only)

Check that all components are received as ordered, and undamaged.

## FACEPIECE FITTING

*Note: This section applies to full facepiece respirators only.*

The SE400 is designed to maintain positive pressure inside the facepiece even under conditions of high workload and stress. However, a quality face seal is essential for optimum protection. This is particularly important in the event that the blower unit stops operating and the SE400 must function as a negative pressure respirator.

A user must pass a Quantitative Fit Test (QNFT) and achieve a fit factor of at least 2000 before being assigned a full facepiece respirator. This is a negative pressure test; i.e.: with the fan unit disconnected or not operating.

### Quantitative Fit Test

A Quantitative Fit Test (QNFT) gives a numerical measure of facepiece fit.

The user wears a respirator in a test atmosphere while an instrument compares the concentration of the challenge agent in the test atmosphere with that inside the facepiece. The test atmosphere may be air contaminated with an aerosol, vapour or gas. With some instruments ambient air can be used.

The QNFT protocol must be in accordance with appropriate government regulations.

Facepiece fit testing has a number of aims:

1. To assess the suitability of the respirator for each person for use in real situations.  
Due to natural variations in human facial features, no one size or style of full facepiece can be guaranteed to fit everyone. A QNFT, properly conducted, can be used to determine if the respirator is suitable for each user.
2. If the respirator is found to be unsuitable, to determine if the same respirator fitted with the Full Face Mask Insert (SEA-FI) is suitable.  
The Full Face Mask Insert is an adhesive-backed foam strip, inserted behind the face seal, intended to accommodate unusual facial features or small faces. Once again, a QNFT must be performed to determine if this configuration is suitable for each user.
3. To train each user in the correct donning technique that will ensure a good facial fit during future use.  
It is extremely important that the donning technique learned by each user during the QNFT is employed in all future use, where fit testing will not normally be available. In particular, the head harness tension used to pass the QNFT should be appropriate for extended use in real situations; if excessive harness tension is needed to pass, the respirator should be considered unsuitable, and should not be used by that person.

### QNFT Procedure

The recommended method for performing the QNFT is with the S.E.A. Fit Test Adapter (FTA-400). Alternatively, a modified test facepiece may be used.

Both methods are described below.



**To prepare for a QNFT using the Fit Test Adapter FTA-400:**

1. Detach the breathing hose from the SE400 facepiece
2. Attach the FTA-400 to the facepiece in place of the breathing hose and attach a HE/P100 particulate filter, following the user instructions provided with the FTA-400. The SE400 facepiece is now configured as a negative pressure respirator. The SE400 fan unit is not required for this test
3. Check that the facepiece, demand valve and FTA-400 are complete and correctly assembled
4. Don the respirator in accordance with section *Donning the SE400* step 2, steps 4 through 8 and step 12

**To prepare for a QNFT using a test facepiece:**

1. Detach the breathing hose from the SE400 facepiece
2. Attach to the breathing hose a modified SE400 test facepiece containing a sampling port connecting to the breathing zone of the facepiece. The test facepiece should be leak tested by a suitable method prior to use.
3. Fully assemble the SE400, including filters. The SE400 can now be tested, with the blower off, as a negative pressure respirator
4. Don the respirator in accordance with section *Donning the SE400* steps 1 through 8 and steps 12 and 15

**To perform a QNFT:**

1. Prepare and don the respirator using one of the methods described above
2. An assistant should inspect the fit of the respirator. Check for significant gaps between the rim of the facepiece and the user's face. If significant gaps are visible, consider fitting the Full Face Mask Insert (SEA-FI). Doff the facepiece, fit the Insert in accordance with its user instructions, and don the facepiece as before.
3. Enter the test atmosphere (if required) and connect the test instrument's sampling tube to the sampling port on the FTA-400 or test facepiece
4. Perform an appropriate QNFT exercise sequence and determine the fit factor
  - i. If the fit factor is 2000 or greater, the respirator should be considered suitable for the user. No further testing is required
  - ii. If the fit factor is less than 2000, an observer should check that the respirator is correctly assembled, and properly fitted in accordance with section *Donning the SE400* step 12. The user should check head harness tension and adjust if necessary. Go to step 5 below
  - iii. If during step ii above the observer detects fitting problems which cannot be overcome by adjustment – in particular, visible gaps between sealing rim and the user's face – the Full Face Mask Insert (SEA-FI) may provide a solution. Doff the facepiece, fit the Insert in accordance with its user instructions, and don the facepiece as before. Go to step 5 below
5. Repeat the QNFT and determine the fit factor
  - a. If the fit factor is 2000 or greater, the respirator in the configuration tested – with or without Insert as appropriate – should be considered suitable for the user. No further testing is required
  - a. If the fit factor is again less than 2000 the respirator should be considered unsuitable and should not be used by that person

*Note: Some "trial and error" is acceptable when carrying out facepiece fit testing. Sound judgement by experienced personnel is essential when assessing the suitability or otherwise of a respirator. Remember that the donning and adjustment method used during testing must be appropriate for subsequent use in real situations.*

## PREPARATION FOR USE

### ***Assembling the SE400***

Before use, check that the SE400 is fully assembled. To assemble, consult the relevant section of the user instructions, as noted below.

- Breathing hose connection to fan unit – consult section *Disassembly and reassembly*
- Breathing hose connection to facepiece – consult section *Disassembly and reassembly*
- SE-talk speaker unit – consult section *Disassembly and reassembly*
- Battery – consult section *Batteries*
- Harness:
  - Standard waist belt – consult section *Waist belt*
  - Back pack – consult user instructions supplied with the back pack
- Dual battery adapter (if required) – consult user instructions supplied with the adapter
- Filtration media – consult section *Filtration media*

### ***Donning the SE400***

The user must be familiar with and practise the donning and doffing procedures prior to respirator use.

#### **Warning**

Men should be clean-shaven, and should not have facial hair such as beards or large sideburns. Facial hair can seriously compromise the face seal and result in reduced protection.

*Note: Before donning a respirator for the first time, perform a facepiece fit test per section Facepiece Fitting (applies to full facepieces only). SEA recommends that each new (unused) respirator be tested for facepiece fit even if the user is experienced with the respirator.*

*Note: Users who have been approved to use the SE400 only with Full Face Mask Insert (SEA-FI) should check that the insert is correctly fitted and is in good condition prior to donning.*

*Note: Before first use and after maintenance, perform a respirator “Self-Test”. Refer section Operation.*

*Note: Users should be well hydrated before donning and using the respirator.*

*Note: When donning the SE400 with an SE-shield protective suit, consult the SE-shield user instructions.*

#### **Procedure:**

1. Visually inspect the respirator for completeness, correct assembly and lack of damage
2. Put the facepiece neck strap over your neck
3. Put on the fan unit (with back pack or waist belt) and adjust the straps
4. Fully loosen the head harness straps
5. Clear all hair away from your face. A thin elasticised head band may be used, provided it is kept clear of the face seal

**For full facepiece only:**



6. Holding the facepiece in one hand and the head harness in the other, place your chin in the cup of the facepiece



7. Pull the head harness over and down the back of your head and stroke it down. Clear any hair away from the face seal



8. Tighten the head harness straps in pairs by pulling the free ends backwards. Start with the neck straps, followed by the temple straps and finally the forehead strap

**For half facepiece only:**



9. Don the half mask so that the harness pad rests on the crown of the head



10. Release the snap-catch at the back of the head, adjust the harness tension, and lock the snap-catch

**For standard waist belt only:**



11. Position the fan unit on the either side of the body as desired. Adjust the breathing hose swivel to position the hose. Mount the SE-Talk on the breast pocket, or on the belt (shown) using the SE-Talk belt attachment HSE



**CAUTION:** The fan unit should always be worn with the filtration media facing downwards or to one side, but never facing upwards.

**For all configurations:**

12. Check that the face seal touches the skin all around, especially under the chin cup and at the temples. Try moving the mask to verify that there is no slippage. The straps should be tightened firmly enough to prevent movement on the face during use, but should not be overly tight. Excessive tightness may lead to increasing discomfort during use. Check once again that there is no hair under the face seal



13. Turn on the fan unit by pressing and releasing the button on the speaker unit. Alternatively, press and release the ON/OFF button on the fan unit

14. Perform a User Seal Check \* by pressing and holding the SE-Talk button for more than three seconds, causing the SE400 to run at full fan speed ("Demist mode"). You should not feel any air leakage around the face seal. After 20 seconds the SE400 automatically returns to normal operating mode. If any leakage is evident, correct immediately by re-stroking the head harness to the back and retighten neck, temple and forehead straps. The straps should be tightened firmly enough to prevent movement on the face during use, but should not be overly tight. Excessive tightness may lead to increasing discomfort during use. Check once again that there is no hair under the face seal



15. Rotate your head and check for comfortable, free movement. Adjust hose swivel at mask end as required.
16. Adjust the level of the speaker unit whilst speaking



17. Check the warning light in front of the mask. It should not be lit. The audible alarm should be silent. If not, investigate. Do not enter a contaminated area until it is resolved
18. Don any outer protective clothing as required. You are now ready to enter a contaminated area.

*\* Note: The User Seal Check is a simple check for gross leakage prior to use. It is not a substitute for a quantitative fit test (QNFT).*

### **Buddy Check**

When entering a contaminated area in groups of two or more, it is good practice to perform a “buddy check”. Pairs of users should visually inspect – but should not adjust – each other’s respirators, checking for things like correct mask positioning, strap tightness, absence of hair in the face seal, correct fitment of battery, hose and hose cover, filters and accessories, etc. Check that the fan unit is operating correctly by observing the status lights panel on the fan unit (refer to section *Operation* for further details).

### **Warning**

If the facepiece has been properly donned and adjusted, detection of contaminant odour or taste, or irritation of eye, nose or throat during use may indicate exhaustion of the filtration media. Return to fresh air immediately without removing the respirator, check facepiece fit and replace filtration media. Used filtration media should be disposed of properly in accordance with state and/or local guidelines for disposal of contaminated material.

(attach CD-ROM here)

## WORKING IN A CONTAMINATED AREA

Before entering a contaminated environment, ensure that the SE400 is suitable for use in that environment. Consult section *Cautions and Limitations*.

For information on the operation of the SE400, see section *Operation*.

- Try to remain relaxed at all times. Breathe normally.
- Do not over-exert yourself if you don't have to. Reducing effort prolongs battery and filtration media life.
- Be aware of the SE400 warnings (facepiece warning light, audible alarm)
- In the event of a malfunction of the SE400, do not panic. Leave the contaminated area quickly but safely. Do not remove the facepiece from your face until you have reached clean air and have been decontaminated. Remember that even without the blower operating the SE400 continues to function as a negative-pressure APR and gives considerable protection.
- If you sense any of the following danger signals:
  - smell or taste of contaminants
  - eye, nose or throat irritation
  - breathing difficulty
  - uncomfortably warm breathing air
  - dizziness, nausea or vomitingimmediately leave the contaminated area. Do not remove the respirator until you have reached clean air and have been decontaminated.
- Be aware of the position of the breathing hose – take care to avoid catching on any objects or obstructions in the work environment

### **Decontamination**

After exposure in a contaminated environment, the respirator and the user may require decontamination in order to prevent contamination of clean areas, and to prevent contamination of and injury to the user and other personnel.

Decontamination procedures should be developed as part of the organisation's respirator program and should be appropriate to the hazards involved.

When developing a decontamination procedure, consider the following guidelines:

- The SE400 is water-resistant. It is NOT waterproof! Never submerge the SE400 in water.
- Leave the speaker unit connected to the fan unit. This will protect the connector terminals.
- Do not remove the facepiece or turn off the blower until after initial decontamination.
- After removing the facepiece, do not allow direct water streams inside the facepiece. Water may enter the fan unit through the breathing hose and cause serious damage.
- Do not use compressed air when cleaning. The SE400 contains sensors for measuring facepiece pressure and ambient pressure that may be damaged.
- Filtration media should always be discarded after decontamination in a shower.
- Batteries can be decontaminated in a water shower. After doing so, shake off the water and place it on a dry surface with the contacts downwards. Batteries should be thoroughly dry before recharging.
- The breathing hose may be fitted with a single-use chemically resistant cover. This cover should be removed and discarded during decontamination. The breathing hose should be decontaminated after the cover has been removed. A replacement cover should be fitted ready for next use. Consult user instructions supplied with the hose cover.

- Do not disconnect the breathing hose from the facepiece or fan unit during decontamination. If disconnected, water may enter and damage the respirator.

*Note: Before decontaminating with a high pressure shower, it is advisable to remove the prefilters, which may become waterlogged and block the airflow.*

*Note: All disposable contaminated material – such as filtration media, prefilters and breathing hose covers – should be disposed of in accordance with state and local guidelines for hazardous waste materials.*

After decontamination, the SE400 should be prepared for reuse. This normally involves:

- thorough cleaning of external surfaces. Do not use solvents on the SE400
- visual inspection for condition and completeness
- replacement or repair of components as required
- recharging of battery(s)
- performing a Self-Test
- ensuring all parts are dry before storage

## STORAGE AND TRANSPORT

The SE400 is designed to withstand harsh working conditions and inhospitable environments. However, proper storage and transport methods will prolong the life of the respirator and ensure it is always capable of optimum performance.

When storing or transporting the SE400, keep in mind the following points:

- Store in clean and dry area
- Store in ambient conditions between  $-20$  and  $+55^{\circ}\text{C}$  ( $-4$  and  $+131^{\circ}\text{F}$ ) and less than 70% relative humidity. Battery may be stored at  $+55^{\circ}\text{C}$  no longer than one month. For longer term storage, consult section *Battery care and maintenance*.
- Protect the respirator and components from potential hazards such as sharp edges, heavy weights, abrasives, chemicals and moisture
- Avoid sources of vibration
- Do not store in direct sunlight
- Gas filters should be stored in airtight containers at all times when not in use

### Warning

Batteries in storage do not retain full charge indefinitely. Periodic recharging is necessary to maintain full charge. Consult section *Batteries* for more information on charging and maintaining batteries.

## COMPONENTS OF THE SE400

### **Fan unit**

The fan unit contains a centrifugal blower for drawing purified air from the canisters and delivering it under pressure to the facepiece via the breathing hose. It is constructed from rugged ABS plastic.

The fan unit has threaded connectors for attachment of filtration media.

The fan unit contains electronics that control the air delivery rate. It also has many advanced functions such as warnings for filter end-of-life and filter missing, logging of important operating data and real-time monitoring of facepiece pressure. It can be connected to a PC for configuring the fan unit parameters and downloading operating data. Consult supplementary manual, *SE400 advanced functions*.

The fan unit model number is located on the identification label on its underside.

Each filter position is fitted with an external thread, gasket and nut for connection to SE-shield suits. Consult the SE-shield user instructions for use.

*Note: The SE-shield suit-sealing nuts should remain fitted to the fan unit at all times, even when not used with a suit, in order to protect the threads from damage.*

### **Breathing hose**

The breathing hose conveys purified air from the fan unit to the facepiece. It also links the facepiece pressure detection, speech microphone and warning light to the fan unit. The flexible hose is made from tough polyurethane.

The breathing hose should remain connected to the fan unit at all times.

The breathing hose model number is located on the attachment to the fan unit, and is not visible when the hose is fitted to the fan unit.

### **SE-shield breathing hose**

The SE-shield breathing hose is used in place of the standard breathing hose when the SE400 is used with SE-shield protective suits. The SE-shield breathing hose directs a small amount of filtered air from the SE400 into the suit, maintaining positive pressure inside the suit. For more information consult section *SE-shield protective ensembles*.

### **Facepiece**

#### **Full facepiece**

The full facepiece is available in a single size to fit all faces. It is available in the following materials:

- Silicone rubber (RF3-FS) for maximum comfort in normal industrial use
- Halo-butyl rubber (RF3-FP or RF3-FP-C) and chloroprene rubber (RF3-FC) for applications where high chemical resistance is required

The full facepiece visor is available in the following materials:

- High-clarity polycarbonate (standard)
- Polycarbonate with hard coating for chemical and scratch resistance (standard on RF3-FP-C, optional on others)
- “Triplex” laminated glass for maximum chemical resistance (optional on all but RF3-FP-C)

The demand valve regulates the air flow to the facepiece in response to the user’s breathing requirements. It is made to S.E.A.’s patented design.





The full facepiece can be identified by the markings:

“RF3” on demand valve attachment inside inner mask



“FS”, “FP” or “FC” on mask body above visor.

“C” on corner of visor (RF3-FP-C only)

*Note: If a good face fit cannot be achieved for a particular user, the S.E.A. Full Face Mask Insert (SEA-FI) may be fitted to the mask to improve the fit. This should be done in conjunction with a face fit testing program. See section Facepiece Fitting.*

## Half facepiece

The SE400 half facepiece is intended for use in general industrial environments. It consists of a one-piece silicone facepiece attached to the demand valve.

The half facepiece is available in three sizes: Small (RH1-S), Medium/Large (RH1-M/L) and Large (RH1-L).

## Demand Valve

The demand valve is attached to the front of the facepiece. It should remain fitted to the facepiece at all times other than for periodic thorough cleaning or if necessary for maintenance.

The demand valve model number is located on the outer surface of the housing.

## Filtration media

### HE filters (particle filters)

High Efficiency (HE) filters (in USA) and particle filters Class P3 (including P1 and P2) (in other countries) protect against all types of airborne particles such as dust, oil mist, smoke, aerosols, bacteria, viruses and mould, with a separation level of more than 99.97%.

Particle filters Class P4 (including P1, P2 and P3) (in countries other than USA) provide protection as per P3 filters but with a separation level of more than 99.997%.

### Chemical cartridges (gas filters)

Chemical cartridges (in USA) and gas filters (in other countries) provide protection against gases in concentrations up to 0.5 per cent by volume or 5,000 ppm. Refer to regulatory guidelines.

### Prefilters

Pre-filters are coarse particulate filters which prevent clogging or other contamination of the main filtration media. Pre-filters should always be fitted to clip-in filtration media, and should be replaced frequently.

The SEA prefilter (221) may be used with any SEA filter. Use prefilter holder PFH-T with threaded filtration media, and prefilter holder 20062 with clip-in filtration media.

## Approval of filtration media

Use only filtration media approved for use with the respirator. (USA) Consult the NIOSH approval label supplied with the respirator and filtration media. (Europe and Australasia) Consult the user instructions provided with the filtration media.

**Note (USA):** SE400 respirators with half facepieces do not provide CN/CS protection.

### Warning

- Only original SEA filtration media, approved for use with the SE400, may be used.
- Chemical cartridges (gas filters) must never be used without HE filters (particle filters) fitted.
- Follow established canister change-out schedules to ensure canisters are replaced before breakthrough occurs.
- Incorrect fitment of filtration media may result in lost or reduced protection of the SE400
- The SE400 should be fitted only with matching filtration media – each filter should have the same part number and age.

### To fit threaded filtration media:

**Note:** Method for SE400AT-2 is shown. For SE46 use the same method but with three filtration media.

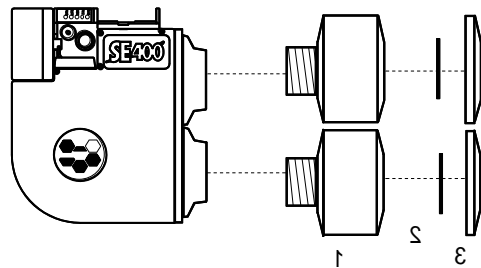

1. Check that the filtration media are of the correct type and class (if unsure, check with supervisor)
2. Check that the model number on the filtration media is correct and that the use-by date has not expired
3. When using new filtration media, check that the sealed packaging is intact and airtight
4. Remove the filtration media from the packaging
5. Check the filtration media for damage. Filtration media with visible physical damage should be discarded immediately
6. Check that the threads on the filtration media and fan unit are clean and the gaskets in the fan unit are clean, undamaged and properly seated
7. Screw each of the filtration media (1) into the fan unit and tighten firmly. Spin the filter until it begins to tighten, then turn another 120° or so (slightly more than a quarter turn). Take care not to overtighten. Note that the fan unit gasket has a self-locking design, so the turning resistance will increase steadily as it is tightened
8. Fit prefilters (2) into prefilter holders (3) and snap them on to inlet of filtration media.

### To fit clip-in filtration media using threaded filter adapters:

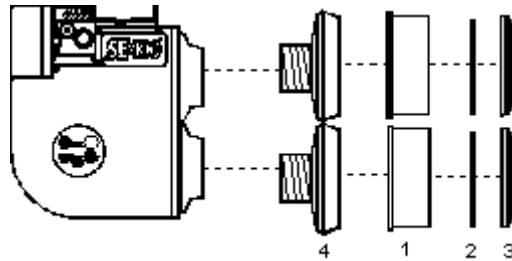

1. Fit threaded filter adapters TA1 or NR280-3 (4) to the fan unit as per steps 6 and 7 above
2. Attach the clip-in filtration media (1) to the adapters. Ensure that the arrows on the labels point towards the fan unit. Make sure that the flanges of the filtration media sit snugly into the rubber grooves in the adapters
3. Fit prefilters (2) into prefilter holders (3) and snap them on to the filtration media.

### To remove the filtration media:

1. Simply unscrew and remove.

## Batteries

The SE400 is powered by one or two rechargeable Nickel Metal Hydride (NiMH) batteries. Batteries can be easily interchanged. If used and maintained correctly a battery will give a service life of up to 500 charge/discharge cycles.

### Single battery configuration

When used in single battery configuration, the battery is fitted directly to the SE400 fan unit.

### Dual battery configuration

The Dual Battery Adapter is used to provide dual battery configuration for the SE400, giving it extended operating time. See section *Dual Battery Adapter*.

### Battery operating time

The operating time of the SE400 when fitted with fully charged battery or batteries greatly depends on the workload of the user, in the same way that a motor vehicle's fuel consumption depends on the load, terrain and manner of driving.

Prolonged periods of high exertion and/or stress will significantly reduce the operating time. In these situations the user can expect a shorter available working time in a contaminated area.

NIOSH has certified the operating time of the SE400 at 4 hours minimum, in both single and dual battery configurations, under standard test conditions (38 litres per minute) when tested on a breathing machine (USA).

### Warning

The above operating times are not guaranteed in real situations. Actual operating times may be significantly longer or shorter, depending on working conditions.

**Note:** Operating time is affected by the following:

- *Conditions of use.* High breathing rates will result in reduced operating time.
- *Level of charge of battery(s).* Only fully charged batteries should be fitted to the SE400 before use.
- *Battery condition.* Batteries degrade over their working lives. A battery nearing the end of its life will have a reduced capacity. A battery should be replaced when the operating time has reduced significantly.
- *Battery temperature.* Towards the upper end of the operating temperature range of the SE400 battery performance diminishes only slightly. At battery temperatures below 5°C (41°F), capacity diminishes sharply. Allow batteries to cool after charging and before use.

## Low battery warning

The SE400 gives a series of audible and visible warnings as the end of operating time approaches. The first low-battery warning occurs at least 5 minutes before the SE400 shuts down. The warning time is independent of the operating conditions.

**Note:** The SE400 provides full breathing performance at all times until the fan unit shuts down due to low battery level.

### Warning

Old batteries in poor condition may cause the low battery warning time to be reduced.

## Battery care and maintenance

Batteries in storage do not retain full charge indefinitely. Periodic recharging is recommended to maintain full charge.

Never allow a battery to become fully flat whilst in storage. A fully discharged battery may suffer permanent degradation over time.

Ideally, batteries should be stored in the temperature range 10 to 25°C (50 to 77°F) to minimise degradation during long-term storage.

Batteries in long-term storage should be recharged at least once per year, and preferably every six months, to minimise degradation.

Optimum battery condition is maintained by storing batteries in the Gang Battery Conditioner (GBCO) (not supplied with the SE400 respirator). When stored in the GBCO, batteries receive regular conditioning cycles and are maintained in ready-to-use condition, with close to full charge. Consult the user instructions provided with the GBCO.

### Warning

If handled incorrectly, NiMH batteries can leak toxic electrolyte, and in some circumstances explosion may occur. Be sure to observe the following safety precautions:

- Never disassemble a battery
- Never short-circuit the terminals of a battery. Do not carry or store a battery with other metal objects as short-circuiting may result
- Never heat a battery or dispose of it by fire. Leakage and explosion may result
- Never leave a battery exposed to direct sunlight, or close to a source of heat, for extended periods whilst not in use
- Never immerse a battery in water or other liquid
- The battery is designed specifically for the SE400 range of respirators. Do not attempt to use it to power any other equipment.

**To attach the battery to the fan unit:**



1. Check that the contacts on the battery and the fan unit are clean and intact
2. Withdraw the locking slide on the fan unit
3. Press the locking tongue
4. Hook the battery onto the fan unit. The two posts on the fan unit should engage with the sockets on the battery
5. Swing the battery into place and release the locking tongue



6. Push the locking slide back into place
7. Check that the battery is securely fastened

**To remove the battery from the fan unit:**



1. Withdraw the locking slide
2. Press the locking tongue, releasing the battery
3. Push the locking slide back into place

## Battery charger (BC3)

The Battery Charger BC3 fully charges a single battery (B1 or later) in five hours.

The charging cycle consists of two phases:

1. Fast charging – battery is charged to approximately 90-95% capacity within two hours
2. “Post trickle charge” – slow charge to reach full capacity.

After charging a battery the charger switches off automatically. Removing a battery and replacing it will restart the charging process.

### To charge a battery:

1. Check that the contacts on the charger and battery are clean and intact
2. Connect the charger to the mains AC supply using the power cable and power supply included with the SE400. The charger’s indicator light flashes red/green for about five seconds, then turns off
3. Insert the battery contacts into recess in the charger
4. Snap the battery into place
5. Observe the indicator light. Normally the battery will commence charging immediately.

## Indicator lights

Light	Status	What to do
STEADY ORANGE	Battery charging normally	Wait until charged
FLASHING ORANGE	Battery temperature too high or too low to commence charging	Wait. Charger will automatically wait until temperature normalises
FLASHING ORANGE/RED	Battery charge too low to commence charging normally. Charger trying to recover battery	Wait. Charger will “trickle charge” until normal charge can commence.
FLASHING GREEN	Battery is charged to approx. 90-95% capacity. Battery is being “post trickle charged”	Use battery now or leave overnight for full charge
STEADY GREEN	Battery fully charged	Use battery now or put aside after removing from charger
FLASHING RED with battery inserted	Faulty battery	Replace battery
FLASHING RED with no battery inserted	Faulty charger	Return charger to vendor for repair

## Battery charger (BC1)

The SE400 can also be used with the Battery Charger BC1. The BC1 is similar to the BC3 except that it continues to “post trickle charge” indefinitely after initial charging. For this reason, a battery may be left charging overnight to reach full charge, but should not be left on for longer periods as damage to the battery may result.

## **Dual battery adapter (DB1)**

Consult Dual Battery Adapter user instructions (100273-03).

The Dual Battery Adapter is used to provide dual battery configuration for the SE400, giving it extended operating time. Typically, dual batteries give approximately twice the operating time of a single battery.

The adapter is connected to the fan unit at its battery attachment, and provides two battery locations, one on each shoulder strap of the backpack.

### **Warnings**

Failure to observe the following may result in reduced breathing protection:

- Always fit two batteries. Never operate the SE400 with Dual Battery Adapter with only one battery
- Ensure both batteries are fully charged
- Do not remove or replace a battery whilst the SE400 is operating
- Do not place the Dual Battery Adapter on the battery charger or the GBCO. It may cause damage to the batteries, charger or GBCO

## **SE-talk speaker unit**

The SE400 is supplied with an SE-Talk speaker unit that provides clear speech output via a microphone mounted inside the respirator. It connects directly to the fan unit.

The SE-Talk is normally mounted on a shoulder strap of the back pack. When the SE400 is used without a back pack, the SE-Talk may be attached to a shirt pocket, or mounted on the SE400 waist belt using the SE-Talk belt attachment (HSE).

The SE-Talk has a single multi-function control for adjusting the speaker output level. The switch can also be pressed to start the SE400. See section *Operation*.

*Note: To ensure clear communication whenever it is needed, the SE-Talk should always be connected while the SE400 is in use.*

*Note: The SE-Talk cannot be switched off. Simply turn the level down fully when not in use.*

*Note: The SE-Talk S1A-20 and S1A-2 can be used only with the SE400AT-2 and SE46. The SE-Talk S1A can be used only with the SE400AT.*

### **To use the SE-Talk:**

1. The SE400 should be donned and running normally
2. Turn the level control fully anti-clockwise. Turn it slowly clock-wise while speaking normally, until a clear, strong sound is produced. Do not adjust the level higher than is needed to produce a clear sound. A good starting point is about half way between minimum and maximum levels.
3. Turn the level down to minimum when speech function is not required.

## **Back pack**

Consult Back Pack user instructions (100267-03).

The Back Pack BP2 is the recommended harness for the SE400. A waist belt extender WB-EX is available for larger waist sizes.

## **Waist belt**

The waist belt WB1 can be used for wearing the SE400 fan unit on the waist. The fan unit may be positioned on either side of the waist. A waist belt extender WB-EX is available for larger waist sizes.

### **To attach the fan unit to a harness:**



1. Slide the clip on the fan unit down over the centre of the attachment on the harness until it snaps home. (Standard waist belt is shown, but the method applies to all types of harness)

### **To remove the fan unit from a harness:**



1. Lift the end of the clip away from the fan unit to release it, then lift the fan unit away



## SE-SHIELD PROTECTIVE ENSEMBLES

*Note (USA): NIOSH does not approve protective suits as part of respirator approvals. For this reason SE-shield suits are not NIOSH approved, nor are they approved for CBRN use. SE-shield suits are not approved as protective suits in the USA.*

*Note: For details on the selection and use of SE-shield suits, contact S.E.A. or consult the SE-shield user instructions.*



SE-Shield is a range of SEA personal protective ensembles for use in hazardous environments.

Each SE-Shield ensemble consists of a pressurised protective suit integrated with the SE400. By directing a small amount of filtered air from the SE400 into the suit via SE-Shield breathing hose, positive pressure is maintained inside the suit. This provides added body protection and perceived cooling without reducing the SE400's high level of breathing protection.

### Configurations

- SE-shield suits should always be used with the SE-shield breathing hose H20-P or H3-E. Do not use the SE-shield breathing hose without an SE-shield suit fitted
- SE-shield suits should always be used with dual batteries (with the dual battery adapter DB1 and back pack BP2)

### The SE-Shield range

#### SE-Shield Tychem F<sup>®</sup>

- Disposable, light-weight, single-use suit
- Chemically impermeable Du Pont Tychem F<sup>®</sup> material
- Integrated, barrier film polymer gloves
- Integrated sock booties in Tychem F<sup>®</sup>
- Elasticised opening for mask visor
- Protects against particles and gases
- Suitable for domestic preparedness applications, with high permeation resistance to war agents such as mustard gas and Sarin
- Optional disposable, single-use hood for even greater protection

#### SE-Shield Tychem QC<sup>®</sup> – Industrial chemicals and dust

- Disposable, light-weight, single-use suit
- Polyethylene-coated Du Pont Tychem QC<sup>®</sup> material
- Elasticised cuffs around wrists, ankles and mask visor
- Protects against particles and gases
- Suitable for protection from industrial chemicals and particles

## **SE-Shield Tyvek® – Dust and other particulates**

- Disposable, light-weight, single-use suit
- Du Pont Tyvek® material
- Elasticised cuffs around wrists, ankles and mask visor
- Protects against particles only
- Suitable for protection from nuisance and hazardous particles, including asbestos

## **SE-Shield HPS**

- Reusable, high performance encapsulated suit
- Suit material Trelleborg Trelchem® HPS is a combination of Du Pont Viton®/butyl rubber coated fabric on the outside and a polymer barrier laminate on the inside
- Impact and chemical resistant transparent PVC visor
- Integrated barrier film gloves with Viton®/butyl rubber outer gloves
- Suitable for domestic preparedness applications, with high permeation resistance to war agents such as mustard gas and Sarin

## **SE-Shield VPS**

- Reusable, vapour protective encapsulated suit
- Suit material Trelleborg Trelchem® VPS is a combination chloroprene rubber coated fabric on the outside and a polymer barrier laminate on the inside
- Impact and chemical resistant transparent PVC visor
- Integrated barrier film gloves with Viton®/butyl rubber outer gloves
- Suitable for domestic preparedness applications, with high permeation resistance to war agents such as mustard gas and Sarin

## **SE-Shield PVC**

- Reusable, PVC coated encapsulated suit
- Suit material polyamide fabric coated with PVC on both sides
- Impact and chemical resistant transparent PVC visor
- Integrated, chloroprene rubber gloves
- Suitable for protection against biological agents such as anthrax and smallpox

# OPERATION

## Visible and audible warnings

### Warning light

The respirator is fitted with a tri-colour warning light which is always visible to the user during use. During any warning condition the warning light flashes in one of the following colours:

- **Red** indicates a critical warning or a mask pressure warning
- **Green** indicates a battery warning or a minor warning
- **Orange** indicates filter conditions

*Note: If multiple warnings occur simultaneously, a red light will always override an orange, and an orange will always override a green. Check the status lights on the fan unit for more information on the warnings.*

### Buzzer



The fan unit has a warning buzzer which sounds during many warning conditions.

### Status lights panel



The fan unit has a panel of five status lights which provide additional information about the warning conditions.

### Warnings label on fan unit

The SE400 fan unit is fitted with a label which summarises the warning conditions likely to be encountered during operation. Models with advanced functionality have an expanded warnings label – refer to supplementary user manual *SE400 Advanced Functions* for more information. Both labels are shown below.

#### Standard label

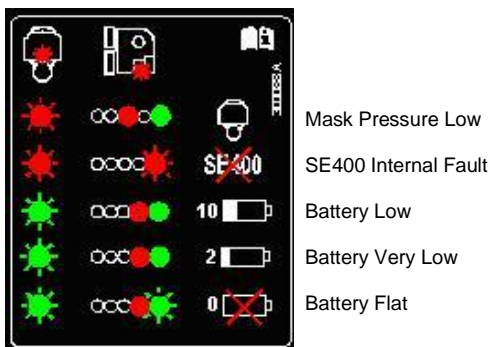

#### Advanced label

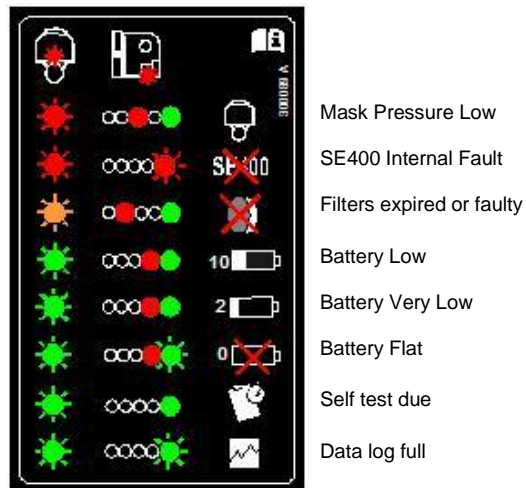





**To start the SE400:**

1. Check that the respirator is fully assembled and is fitted with a charged battery or batteries
2. Press and release the ON/OFF button on the fan unit. Alternatively, press and release the button on the SE-Talk speaker unit

The SE400 will start and perform an internal self-check, during which the battery charge level will be indicated on the status lights panel. This sequence takes about five seconds.

**Warnings during start-up**

Lights	Status	Condition	What to do
	FIVE steady RED lights	STRONG charge	No action required
	THREE steady RED lights	MEDIUM charge	Be prepared to change battery during shift
	ONE steady RED light	WEAK charge	Recharge battery or replace with fully charged battery
	PWR flashing GREEN + steady BATT indicator MOTOR DOES NOT START	Battery is FLAT	Recharge battery or replace with fully charged battery

If the SE400 is functioning normally, the PWR status light will be steady green.

Lights	Status	Condition	What to do
	PWR steady GREEN	All functions normal	Work normally



Put on the respirator (see section *Donning*) and breathe normally. After a few breaths it will respond to your breathing.

If you wait longer than one minute before putting on the SE400, it will shut down automatically.

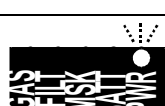
If the SE400 is not running normally, one of the following warnings will be indicated:

Lights	Status	Condition	What to do
	PWR flashing RED <b>MOTOR DOES NOT START</b>	Fundamental operation fault	The SE400 cannot be used. Return to supervisor
	PWR flashing RED <b>MOTOR RUNS AT FULL SPEED</b>	Secondary operation fault	The unit can only be used in emergency mode. Return to supervisor

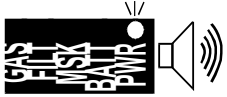
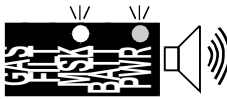
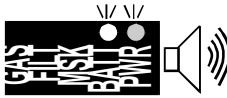
## Warnings during operation

Warning light	Status lights and buzzer	Condition	What to do
RED		PWR flashing RED.  MOTOR SHUTS DOWN!	Critical Warning Major fault  Keep respirator on your face. Move <b>immediately</b> to safe area **. Return SE400 to vendor for repair.
RED		MSK steady RED, PWR steady GREEN, Continuous buzzer	Negative pressure in the facepiece. User has momentarily exceeded air flow of SE400, or a respirator fault.  If warning continues, move to safe area **. Check equipment to find the cause of the problem
GREEN		BATT steady RED, PWR steady GREEN Buzzer sounds once per minute	Low battery power Approx 5 to 10 minutes of operation left *  Move to safe area ** Recharge battery, or replace with a fully charged one
GREEN		BATT steady RED, PWR steady GREEN Continuous buzzer	Very low battery power Approx 2 minutes of operation left *  Move quickly to safe area **. Recharge battery, or replace with a fully charged one
GREEN		BATT steady RED, PWR flashing GREEN  MOTOR SHUTS DOWN	Battery is FLAT  Keep respirator on your face. Move <b>immediately</b> to safe area **

\* These times can vary considerably depending on the condition of the battery.

\*\* "Safe area" refers to an uncontaminated area.

### To stop the SE400:

Press and release the ON/OFF button on the fan unit

or

Remove the facepiece from your face. The SE400 will shut down automatically after one minute.

*Note:* The SE400 cannot be turned off using the button on the SE-Talk speaker unit, to prevent accidental shut-down.

### Stand-by mode

If the facepiece is removed from the face, an alarm will sound and the SE400 will enter stand-by mode for one minute.

If the facepiece is refitted within one minute the SE400 will resume normal operation.

If the facepiece is not refitted within one minute the SE400 will shut down automatically.

## **Demist mode**

When set to demist mode the SE400 delivers maximum airflow for 20 seconds before automatically returning to normal operating mode. It can be used for:

- demisting the visor
- performing a quick check of facepiece fit
- inflating an SE-shield suit

To enter demist mode, the SE400 must first be in normal operating mode.

Press and hold for more than 3 seconds the ON/OFF button on the fan unit or the button on the SE-Talk speaker unit.

### **Caution**

Demist mode should not be used repeatedly as it can dramatically reduce battery operating time.

*Note: System monitoring does not function when in demist mode.*

## **Menu mode**

Menu mode allows the user to:

- perform a Self-Test on the SE400 or
- filter life reset (refer to supplementary manual – SE400 advanced functions)

Menu mode is operated using the ON/OFF button on the fan unit while observing the status lights panel.

## **Self-Test**

The Self-Test is a simple, automated test that the user can perform periodically to check the function and calibration of the SE400. It is a test only. No recalibrations or adjustments are performed.

A “Self-Test” should be performed before first use of the respirator and after any maintenance work has been done. Periodic “Self-Tests” can be scheduled to suit the organisation’s respirator program.

### **To perform a Self-Test:**

1. The SE400 must be complete, including filtration media. Ensure that air can flow freely from the facepiece.
2. With the SE400 off, enter menu mode by pressing and holding the start button for five seconds when the PWR status light will turn steady red.
3. Select and activate Self-Test by following the Menu Mode Sequence (see figure “Menu Mode Functions”). The PWR status light will flash green, indicating that the test is in progress
4. After a moment the fan will run at high speed. When the fan unit beeps while running, hold the facepiece firmly against your face while holding your breath to block the airflow from the facepiece. Hold for two or three seconds until the fan unit beeps again. The test is now complete.

If the test passes, the PWR status light will be steady GREEN. The fan unit will shut down shortly after. The SE400 is ready for use.

If the test fails, the PWR status light flashes GREEN and one or more lights will come on steady RED, depending on the cause of failure:

- MSK steady RED indicates a problem with the mask pressure system
- FILT steady RED indicates a problem with the filter pressure system
- GAS steady RED indicates a problem with the air flow measurement system

## Warning

If a Self-Test fails, the respirator should not be used until the problem has been rectified and has again passed a Self-Test. Contact the vendor, S.E.A. or a technician trained in maintenance of the SE400.

*Note:* When the Self-Test encounters a fault, often it will not complete the remaining tests in the cycle. The lights stay on for one minute, or until the ON/OFF button is pressed.

*Note:* If the battery is in poor condition the Self-Test may abort and shut the SE400 down. In such cases the battery should be checked. Consult section Batteries.

### Menu Mode Functions

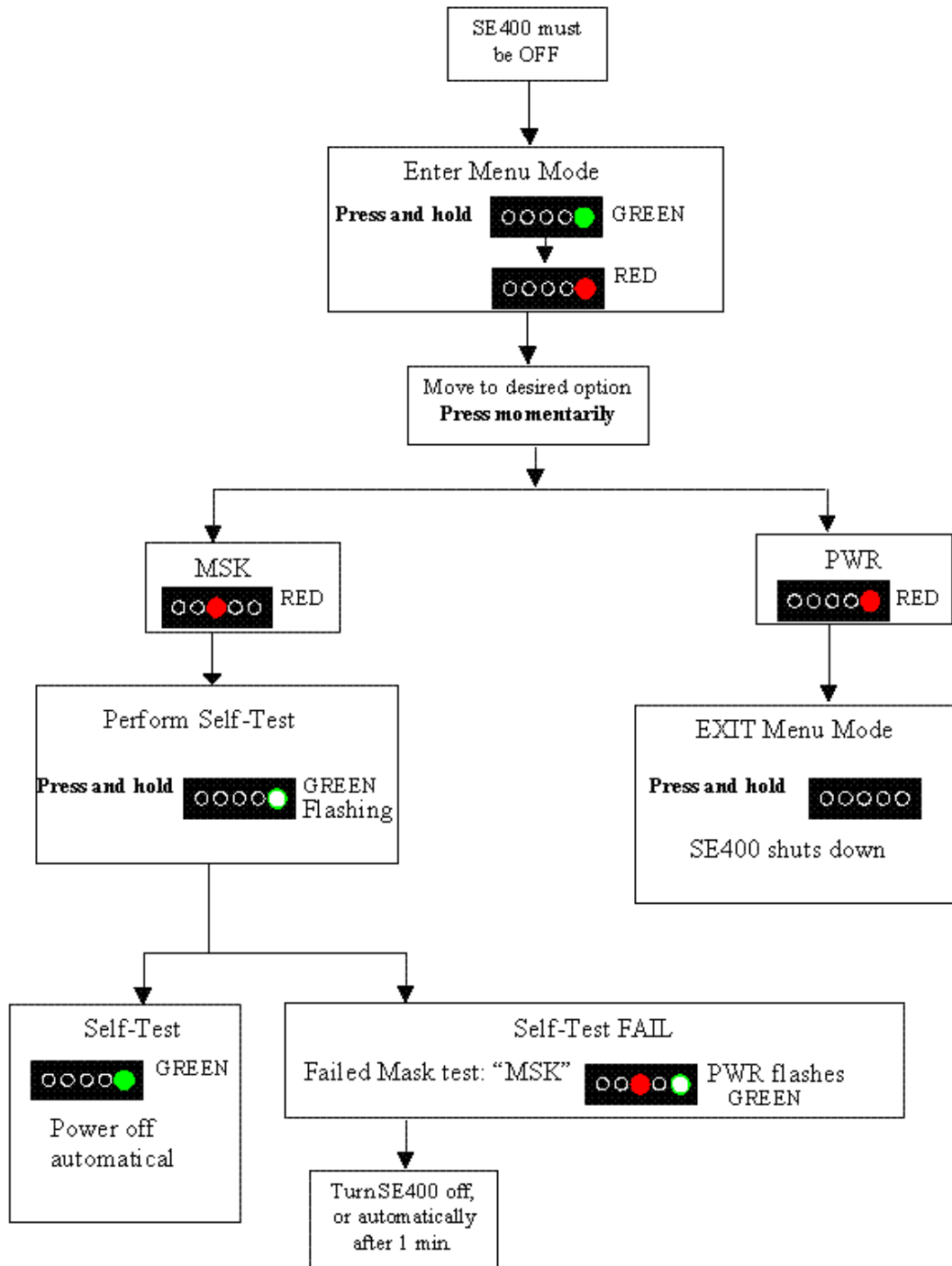

## DISASSEMBLY AND REASSEMBLY

When disassembly and reassembly is required, use the following procedures.

### To disconnect the SE-Talk from the fan unit:



1. Turn the collar on the plug anti-clockwise to unlock it
2. Pull the plug from the socket

### To connect the SE-Talk speaker to the fan unit:



1. Insert the SE-Talk plug into the fan unit socket, being sure to align the mating tongue and groove



2. Turn the collar on the plug clockwise to lock it
3. Turn the SE-Talk to minimum level (fully anti-clockwise)



**To detach the breathing hose from the facepiece:**



1. Squeeze the tabs of the hose fitting between thumb and forefinger of one hand



2. Push the lower part of the hose fitting towards the demand valve, causing the tabs to release
3. Pull the hose away from the demand facepiece

**To attach the breathing hose to the facepiece:**



1. Hook the bottom part of the hose fitting inside the demand valve opening



2. Insert the tabs on the hose fitting inside the facepiece adapter. You may need to guide the tabs.
3. Push the hose fitting in until the tabs snap home.

**To detach the breathing hose from the fan unit:**

*Note: This operation should only be required when changing the breathing hose.*



1. Undo the two cross-recess screws and remove the retainer.



2. Remove the retainer.



3. Release the clip by pushing out its upper end
4. Carefully swing the hose attachment away from the fan unit. Disconnect the microphone plug from inside the fan unit opening.

**To attach the breathing hose to the fan unit:**



1. Insert the microphone plug into its jack inside the flow chamber of the fan unit
2. Hook the two pins on the hose fitting into the hinge slots on the fan unit
3. Swing the hose fitting into place and lock into place with the clip
4. Fit the retainer over the latch and fasten with screws. Take care not to over-tighten the screws as the plastic threads may be damaged.

## CLEANING AND MAINTENANCE

### ***Reconditioning after each use***

The respirator should be reconditioned after use in readiness for future use.

1. If the facepiece has been disconnected from the breathing hose, wash the facepiece/demand valve thoroughly in warm soapy water. Thorough washing is essential before issuing the respirator to a different user. See section *To wash the facepiece*.
2. If the facepiece has not been disconnected from the breathing hose, wipe the face sealing surfaces and internal surfaces with a moistened cloth or with a special face wipe.
3. Wipe all external surfaces with a moistened cloth.
4. Recharge battery(s) as required. See section *Batteries*.
5. Ensure all parts are dry before storage.

### **Important**

Do not use solvents when cleaning the respirator.

### **To wash the facepiece:**

Leave the demand valve attached to the facepiece. Do not remove the demand valve before washing.

1. Detach the breathing hose from the facepiece. See section *Disassembly and Reassembly*.
2. Wash the facepiece in lukewarm water with a mild detergent. If necessary, use a soft brush. Do not use abrasive materials. Take great care not to scratch the visor as this can impair vision.
3. Alternatively, the facepiece can be placed in a protective bag and machine-washed. Water temperature should not exceed +40°C (104°F).
4. Rinse the facepiece in clean water, shake off excess water and leave to air-dry at room temperature, preferably overnight.
5. Once dry, the visor may be cleaned with a soft cotton cloth.
6. Check that the exhalation valves are in place and in good working order.
7. Reattach the breathing hose to the facepiece. See section *Disassembly and Reassembly*.

### ***Cleaning the demand valve***

The demand valve is normally cleaned while still fitted to the facepiece, as described above. The demand valve should be thoroughly cleaned at longer intervals, typically annually. This task requires the removal of the demand valve from the facepiece.

## Warning

Handle all demand valve parts with extreme care. Damage to any parts will affect the breath response of the respirator. In particular:

- Do not bend or distort the demand valve spring
- Do not tear or puncture the demand valve membrane or exhalation valves

### To remove the demand valve from the facepiece:



1. Insert a coin between the demand valve body and the facepiece adapter. While pressing on the latch, twist the coin to release the demand valve
2. Lift the demand valve away from the facepiece

### To thoroughly clean the demand valve:

1. Peel the silicone demand valve membrane away from the housing. The demand valve spring will be released.
2. Peel the membrane away from the piston.
3. Lift the exhalation valve covers away from the housing.
4. Remove the exhalation valves
5. Wash all parts carefully in warm soapy water. Use a soft cloth to remove stubborn grime. Do not use abrasive materials. Take great care not to damage any parts.
6. Rinse all parts in clean water, shake off excess water and leave to air-dry at room temperature, preferably overnight.
7. Inspect both exhalation valve seats. They must be clean, dry and free of dust. There should be no scratches or other damage on the seats. If damaged, replace the demand valve.
8. Inspect the exhalation valves. They, too, must be undamaged, clean, dry and free of dust. If damaged, replace the exhalation valves.
9. Fit each exhalation valve to its seat by pressing the slots in the valves onto the ribs on the housing. Check that each valve rests flat on its seat.
10. Check that the exhalation valve covers are undamaged. Snap them into position.
11. Stretch the membrane carefully around the piston. Check that the inner rim of the membrane engages with the groove in the piston all the way around.
12. With the housing inverted on a flat surface, place the spring in the centre.
13. With the small holes in the membrane and housing aligned, lower the piston and membrane, compressing the spring.
14. Run your fingers around the rim of the membrane so that it engages with the rim of the housing all the way around.
15. Check that the small hole in the top of the membrane aligns exactly with the hole in the housing. Press the piston in and out a few times to be sure it is aligned.
16. If the hole is misaligned, rotate the membrane slightly by sliding its attachment to the housing.

**To attach the demand valve to the facepiece:**



1. Check that the demand valve mechanism is correctly assembled. The membrane should be seated neatly all the way around the piston
2. The piston and membrane should move in and out freely with finger pressure
3. Check that the small hole in the top of the membrane aligns exactly with the hole in the housing. If the hole is misaligned, rotate the membrane slightly by sliding its attachment to the housing (see above).
4. Check that the perimeter of the membrane and the seating surface in the facepiece are clean and free of defects
5. Place the demand valve over its attachment position in the facepiece. Snap the housing into the latch at the base of the facepiece
6. Check that the membrane perimeter is seated properly in the facepiece receptacle
7. With the palms of both hands, push the demand valve into the receptacle, starting at the bottom and “rolling” towards the top, until the top snaps into place

**Important**

A self-test should always be performed after any work involving removal or dismantling of the demand valve.

*Note: Superseded RF1 full facpieces are compatible only with superseded DV2 demand valve. RF3 full facpieces may be used only with DV3 and DV3-C demand valves. RH1 half facpieces may be used with DV2, DV3 and DV3-C demand valves.*

## Replacing the visor (full facepiece)

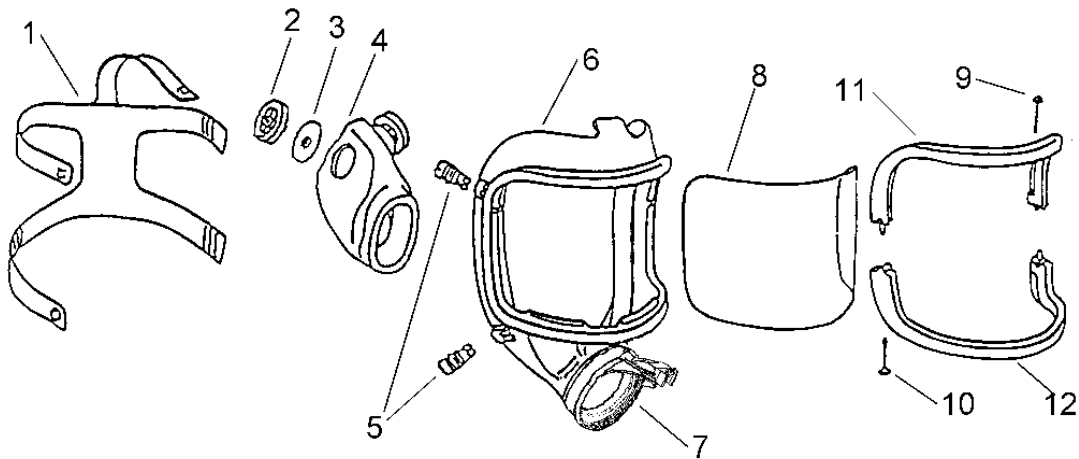

1. Remove the two visor screws (9, 10), loosen the visor frames (11, 12) and remove the visor (8)
2. Thoroughly clean the rubber groove around the visor seal
3. Place a new visor in the faceblank (see markings “up/down” on the visor) and align the centre marks on the visor and facepiece body
4. Working from the bottom centre, turn the rubber groove over the visor, working evenly on both sides at once, checking regularly that the centre marks remain aligned
5. When the visor is fully inserted, check that the mask is not distorted. If necessary, adjust the positioning of the visor in the facepiece
6. Fit the two visor frame halves, fit the screws and tighten, taking care not to over-tighten. Check that the facepiece lip sits evenly in the frame right around the visor, otherwise leakage may result.

### Important

A self-test should always be performed after dismantling the visor.

S.E.A. recommends performing a quantitative fit test (QNFT) or other facepiece leak test to ensure the facepiece is leak-tight. Refer to section *Facepiece Fitting*.

## SPARE PARTS AND ACCESSORIES

Part	S.E.A. order code
Fan unit	SE400AT-2, SE46
Full facepiece	RF3-FS, RF3-FC, RF3-FP, RF3-FP-C
Half facepiece	RH1 S, RH1 M/L, RH1 L
Demand valve only	DV3-C, DV3
Breathing hose	H20, H2-E
SE-shield breathing hose	H20-P, H3-E
Battery	B1
Battery charger	BC3
Power supply with cable for charger	PS1-U (USA), PS1-A (AUS), PS1-NE (EUR)
AC power cord for charger	PC-USA (USA), PC-AUS (AUS), PC-NE (EUR)
Power supply (12 V) for vehicle	PSV-12
Gang battery conditioner	GBCO
Dual battery adapter	DB1
Back pack	BP2
Waist belt	WB1
Waist belt extension	WB-EX
SE-talk speaker unit (for SE400AT-2, SE46)	S1A-20, S1A-2
SE-talk speaker unit (for SE400AT)	S1A
Data cable (for SE400AT-2, SE46)	DC-A-2
Data cable (for SE400AT)	DC-A
Spectacle frames	FSF-T
SEA FF Mask Foam Insert	SEA-FI
Battery lock for fan unit	BL
Breathing hose latch kit	LKH
Breathing hose latch retainer with screws	HLR
Breathing hose gasket EPDM, supply end	GH-20
Threaded nuts for attachment to SE-shield (set of 3)	SSN-46
Suit sealing gaskets EPDM for SE-shield (set of 3)	SSG-EPDM
Fan unit attachment clip	BB
Polycarbonate visor (not for RF3-FP-C)	VP
Hard coated polycarbonate visor (not for RF3-FP-C)	VHC
Triplex laminated glass visor (not for RF3-FP-C)	VLG
Disposable visor covers (pkt 10)	VC
Silicone head harness (full facepiece)	FHS
Natural rubber head harness (full facepiece)	FHN
Cloth head harness (full facepiece)	FHC
Single strap head harness (half facepiece)	HH-H-SS
Cradle head harness (half facepiece)	HH-H-CR
Valve discs for orinasal cup (set)	FF-V
Valve seats and pins for orinasal cup (set)	FF-IMVS
Harness buckles with retainers (set of 5)	FF-B
Neck strap	FF-NS
Demand valve membrane	M-DV
Demand valve piston	IR-DV
Demand valve spring	S-DV
Exhalation valves (pair)	EVS-DV2
Exhalation valve covers (pair)	EVC-DV2
Exhalation valve shield	EVS
Prefilter	221
Prefilter holder (threaded filters)	PFH-T
Prefilter holder (clip-in filters)	20062
Threaded filter adapter for clip-in filters	TA1
Spark protector (threaded filters)	SP-T
Welding visor (for full facepiece)	WV
Welding glass shades	WGS-10, 11, 12, 13
Welding glass shade, clear	WGS-CL
Welding cover for breathing hose	W-PFZ-H
Tyvek <sup>®</sup> dust cover for breathing hose	TYV-H
Tychem F <sup>®</sup> breathing hose cover (single use)	HC-TF
Tychem F <sup>®</sup> single-use hood	H-TYVF
PVC hood	H-PVC
Welding hood	H-W-PFZ
Welding hood with bib	H-W-PFZ-B
Tyvek <sup>®</sup> dust hood	H-TYV
Tyvek <sup>®</sup> dust hood with bib	H-TYV-B
SE-shield suits	Contact S.E.A. or consult separate user instructions

## TROUBLESHOOTING

Status lights	Possible causes	What to do
MSK indicator steady RED	a) Leakage in the mask pressure hose system	<p>Check that the demand valve housing is fitted correctly in the adaptor.</p> <p>Check that the breathing hose is fitted correctly in the demand valve housing.</p> <p>Check that the breathing hose is fitted correctly to the fan housing.</p> <p>Loosen the breathing hose from the fan housing and check that there is no dirt where the pressure hose connects to the fan housing.</p> <p>Loosen the breathing hose from the demand valve and check that there is no dirt where the hose connects to the demand valve.</p> <p>Remove the demand valve housing from the adaptor and check that there is no dirt and that the membrane is correctly located in the groove in the adaptor.</p>
	b) Blockage in the mask pressure hose system	<p>Remove the breathing hose from the fan unit and the demand valve.</p> <p>Remove the demand valve from the adaptor.</p> <p>Check all openings in the pressure hose system.</p> <p>Check that the holes in the diaphragm and housing line up.</p> <p>Blow carefully with the breath in the pressure hose connection in the lower end of the breathing hose.</p> <p>For more information see section on cleaning and maintenance.</p> <p><b>NOTE: NEVER USE COMPRESSED AIR WHEN DOING THIS, AS HIGH PRESSURE MAY DAMAGE THE PRESSURE SENSORS.</b></p>
	c) Pressure sensor out of calibration or an internal fault in the SE400 electronics.	Send the unit to nearest SEA service for repair and/or calibration
RED light on Fast Charger as battery is inserted in charger	Battery error	<p><b>DO NOT</b> use the battery in the SE400, even if it seems to work.</p> <p>Remove battery, clean contact points and try again.</p> <p>Attach battery to charger with the power off, and then turn on power.</p> <p>Try another battery.</p> <p>If another battery works, there is an internal battery error. Replace battery.</p>



## OPERATION IN EXTREME CONDITIONS

The operating range for the SE400 is 0° to +55°C, 0 to 90% relative humidity.

The SE400 will operate in temperatures below 0°C (32°F), but the following temperature effects must be kept in mind when using in such conditions:

- There is potential for icing to affect performance. Take care to ensure the SE400 is functioning properly during use. If abnormal operation – such as lack of response to changes of breathing pattern – is observed, the user should leave the contaminated area immediately. Any malfunctions should be investigated before returning the respirator to service.
- The capacity of the battery can be reduced significantly when used at temperatures below 0°C (32°F).
- S.E.A. does not guarantee the performance of the SE400 when used at temperatures below 0°C (32°F).

## SE-DATA

SE-Data is a comprehensive personal protection management tool, designed to help organisations develop and implement a company-wide personal protections program. It includes an extensive database of hazardous materials.

## IMPORTANT WARRANTY INFORMATION

**The warranty on the SE400 respirator is NULL AND VOID if:**

- The respirator is operated at any time without filtration media correctly attached
- Filtration media are not replaced according to the manufacturer's recommendation, an established change out schedule or when prompted by the respirator's alert functions
- Any disassembly of the respirator other than as described in these user instructions is carried out by any person other than a qualified S.E.A. technician.

## IN CASE OF HEAVY IMPACT

**If the respirator receives a heavy impact, such as being dropped:**

- Check that the filtration media are still firmly attached and tightened correctly
- Perform a Self-Test to ensure the respirator functions properly
- Inspect thoroughly for physical damage. If damaged, contact S.E.A. The unit should also be leak tested.

## APPROVAL BODIES

### Important

All of the issuing authorities below are responsible only for their own territories and jurisdictions. No issuing body supports, favours or endorses the standards issued by any other body.



#### WorkCover Information Centre

Telephone: 13 10 50

Fax: 02 9287 5491

Hours: 8:30am to 5:00pm weekdays

#### WorkCover Switchboard

Telephone: 02 4321 5000

Fax: 02 4325 4145

TTY: 02 4321 5455

#### Head Office

92-100 Donnison Street, GOSFORD NSW 2250 Australia

Phone: +61 2 4321 5000 Fax: +61 2 4325 4145

Email: [contact@workcover.nsw.gov.au](mailto:contact@workcover.nsw.gov.au)

Office Hours: 8:30am - 5:00pm Monday to Friday

#### Postal Address

WorkCover NSW, Locked Bag 2906, Lisarow, NSW 2252

WorkCover Publications Order Line: 1300 799 003

For address, telephone or fax details of all WorkCover offices:

Visit: <http://www.workcover.nsw.gov.au>

Contacting us electronically:

Email: [contact@workcover.nsw.gov.au](mailto:contact@workcover.nsw.gov.au)



#### Customer Service Centre

Phone

From within Australia 1300 65 46 46

From overseas +61 2 8206 6010

Fax

From within Australia 1300 65 49 49

From overseas +61 8206 6020

E-mail [sales@standards.com.au](mailto:sales@standards.com.au)

Mail

Standards Australia,

GPO Box 5420

Sydney NSW 2001

## Important

All of the issuing authorities below are responsible only for their own territories and jurisdictions. No issuing body supports, favours or endorses the standards issued by any other body.



### **INSPEC International Limited** (notified body number 0194)

56 Leslie Hough Way

Salford

Greater Manchester

M6 6AJ

United Kingdom

Tel: +44 (0) 16 1737 0699

Fax: +44 (0) 16 1736 0101

Testing services: Email: [testing@inspec-international.com](mailto:testing@inspec-international.com)

Certification services: Email: [certification@inspec-international.com](mailto:certification@inspec-international.com)

This product is CE-approved by INSPEC International Limited. Conformity assessment was made against technical specification *Fan Supplied Positive Pressure Breath Responsive Respirators – Test protocol for assessment against the requirements of PPE Regulation (EU) 2016/425*, assuring conformity to the Essential Health and Safety Requirements of PPE Regulation (EU) 2016/425. The manufacturer's Declaration of Conformity can be found at [www.sea.com.au/seshield/docs/std\\_se400\\_eu\\_doc\\_0656.pdf](http://www.sea.com.au/seshield/docs/std_se400_eu_doc_0656.pdf)



### **Phone**

1-800-CDC-INFO (1-800-232-4636)

Outside the U.S. 513-533-8328

TTY 1-888-232-6348

Customer Service Representatives are available 24 hours/day, 7 days/week in both English and Spanish.

### **Email and website**

Go to <http://www.cdc.gov/niosh>



### **Safety Equipment America, Inc.**

22 Horsford Avenue, Rumford, RI 02916, USA  
TollFree (USA and Canada only): 949 200 6243  
Email: [sea.america@theseagroup.com](mailto:sea.america@theseagroup.com)

### **Safety Equipment Europe AB**

Org. No.: 556518-3711  
Storgatan 64, S-331 31 Värnamo, Sweden  
Telephone: [+46] (0)370 69 34 40 Fax: [+46] (0)320 179 79  
Email: [sea.europe@theseagroup.com](mailto:sea.europe@theseagroup.com)

### **Safety Equipment Australia Pty Ltd**

A.B.N.: 29 002 727 586  
Unit 35 1 Jubilee Avenue, Warriewood NSW 2102, Australia  
Mail: Private Bag, Mona Vale NSW ;2103, Australia  
Telephone: [+61] (0)2 9910 7500 Fax: [+61] (0)2 9979 5364  
Email: [sea.australia@theseagroup.com](mailto:sea.australia@theseagroup.com)

*Tychem F<sup>®</sup>, Tychem QC<sup>®</sup> and Tyvek<sup>®</sup> are registered trademarks of the Du Pont Corporation*

Copyright © 2018 The S.E.A. Group under the Berne Convention and the Universal Copyright Convention. All rights reserved.

Rev M per CN 1314