

STAINLESS STEEL INDIRECT WATER HEATERS

INSTALLATION, OPERATION and MAINTENANCE INSTRUCTIONS

TABLE OF CONTENTS

IMPORTANT INFORMATION	2.
GENERAL INFORMATION	3.
PRE-INSTALLATION	6.
LOCATION	6.
WATER CONNECTIONS	6.
TEMPERATURE AND PRESSURE RELIEF VALVE	7.
BOILER CONNECTIONS	8.
BOILER SYSTEM.....	9.
ELECTRICAL CONNECTIONS	9.
WATER TEMPERATURE ADJUSTMENT.....	9.
OPERATING INSTRUCTIONS	10.
MAINTENANCE	11.

IMPORTANT INFORMATION

The equipment must be installed in accordance with those installation regulations required in the area where the installation is to be made. These regulations must be carefully followed in all cases. Authorities having jurisdiction shall be consulted before installations are made. All wiring on water heaters installed in the USA must be in accordance with the National Electrical Code and/or local regulations; or in Canada, installed in accordance with the Canadian Electrical Code and/or local regulations.

The following terms are used throughout this manual to bring attention to the presence of hazards of various risk levels, or to important information concerning product life.

DANGER

Indicates an imminently hazardous situation, which, if not avoided, will result in death, serious injury, or substantial property damage.

CAUTION

Indicates a potentially hazardous situation, which, if not avoided, could result in death, serious injury, or substantial property damage.

WARNING

Indicates a potentially hazardous situation, which, if not avoided, may result in moderate, or minor injury or property damage.

NOTICE

Indicates special instructions on installation, operation or maintenance, which are important but not related to personal injury hazards.

GENERAL INFORMATION

For your family's comfort, safety, and convenience, we recommend this water heater be installed and serviced by a plumbing professional.

WARNING

To avoid damage or injury, there must be no materials stored against the indirect water heater and proper care shall be taken to avoid unnecessary contact (especially by children) with the indirect water heater. Do not store or use gasoline or other flammable liquids in the vicinity of this water heater or any other appliance.

DANGER

DO NOT store or use gasoline or other flammable, combustible, or corrosive vapors and/or liquids in the vicinity of this or any other appliance.

IF YOU SMELL GAS:

DO NOT try to light any appliance.

DO NOT touch any electric switch; do not use any telephone in your building.

Immediately call your gas supplier from a telephone in another building. Follow the gas supplier's instructions.

If you cannot reach your gas supplier, call the fire department.

DO NOT OPERATE THE APPLIANCE UNTIL THE LEAKAGE IS CORRECTED!

Liquefied petroleum gas/propane gas is heavier than air and will remain at floor level if there is a leak. Basements, crawl spaces, closets, and areas below ground level will serve as pockets for accumulation of leaking gas.

This water heater is supplied with an adjustable thermostat to control water temperature. Hot water temperatures required for automatic dishwasher and laundry use can cause scald burns resulting in serious personal injury and/or death. The temperature at which injury occurs varies with the person's age and the time of exposure. The slower response time of disabled persons increases the hazards to them. **NEVER** allow small children to use a hot water tap or to draw their own bath water. **NEVER** leave a child or disabled person unattended in a bathtub or shower.

WARNING

Installation is not complete unless a pressure and temperature relief valve is installed into the side of the water heater. This water heater contains very hot water under high pressure. Do not unscrew any pipe fittings or attempt to disconnect any components of this water heater without positively assuring the water is cool and has no pressure. Always wear protective clothing and equipment when installing, starting up, or servicing this water heater to prevent scald injuries. Do not rely on the pressure and temperature gauges to determine the temperature and pressure of the water heater. This water heater contains components that become very hot. Do not touch any components unless they are cool. Improper installation, adjustments, alteration, service or maintenance can cause property damage, personal injury or loss of life. Failure to follow all instructions in the proper order can cause personal injury or death. Read and understand all instructions, including all those contained in component manufacturer's manuals, which are provided with the appliance before installing, starting-up, operating, maintaining, or servicing this appliance. Keep this manual and literature in legible condition and posted near the appliance for reference by owner and service technician. This water heater requires regular maintenance and service to operate safely. Follow the instructions contained in this manual. Installation, maintenance, and service must be performed only by an experienced, skilled, and knowledgeable installer or service agency.

WARNING

It is the responsibility of the installing contractor to see that all controls are correctly installed and are operating properly when the installation is complete.

DO NOT operate the water heater with jumped out or absent controls or safety devices.

DO NOT tamper with or alter the water heater and/ or controls.

DO NOT operate the water heater if any external part has been under water. Immediately call a qualified service technician to inspect the appliance and to replace any part of the control system that was under water.

DO NOT install this water heater on carpeting. This water heater is suitable for installation on combustible flooring.

DO NOT operate this water heater without first being certain it is filled with water.

Flammable items, pressurized containers, or any other potential fire hazardous articles must never be placed on or adjacent to the heater. Containers of flammable gases should not be stored or used in the same room with this water heater. Hydrogen gas can be produced in an operating water heater that has not had water drawn from the tank for a long period of time (generally two weeks or more). Hydrogen gas is extremely flammable. To prevent the possibility of injury under these conditions, we recommend that the water faucet be opened for several minutes at the kitchen sink before you use any electrical appliance that is connected to the hot water system. If hydrogen is present, there will be unusual sounds such as air escaping through the pipes as hot water begins to flow. Do not smoke or have open flame near the faucet at the time it is open.

CAUTION

The maximum boiler water supply temperature to the indirect heat exchanger must not exceed 200°F (93°C).

NOTICE

Insulation blankets are not required for this water heater. This water heater meets or exceeds the ASHRAE/IES 90.1b standards with respect to insulation and standby loss requirements.

NOTICE

The maximum heat transfer through the coil (heat input) of the water heater at 200°F (93°C) boiler water supply temperature and 210°F potable water temperature is 94,000 Btu/hr. Potable water temperature is limited to below 210°F and nominal water containing capacity is less than 120 gallons for all indirect models. Accordingly, per Part HLW-101.2, Section IV of the ASME Boiler and Pressure Vessel Code, all indirect products are therefore exempted from compliance with the code.

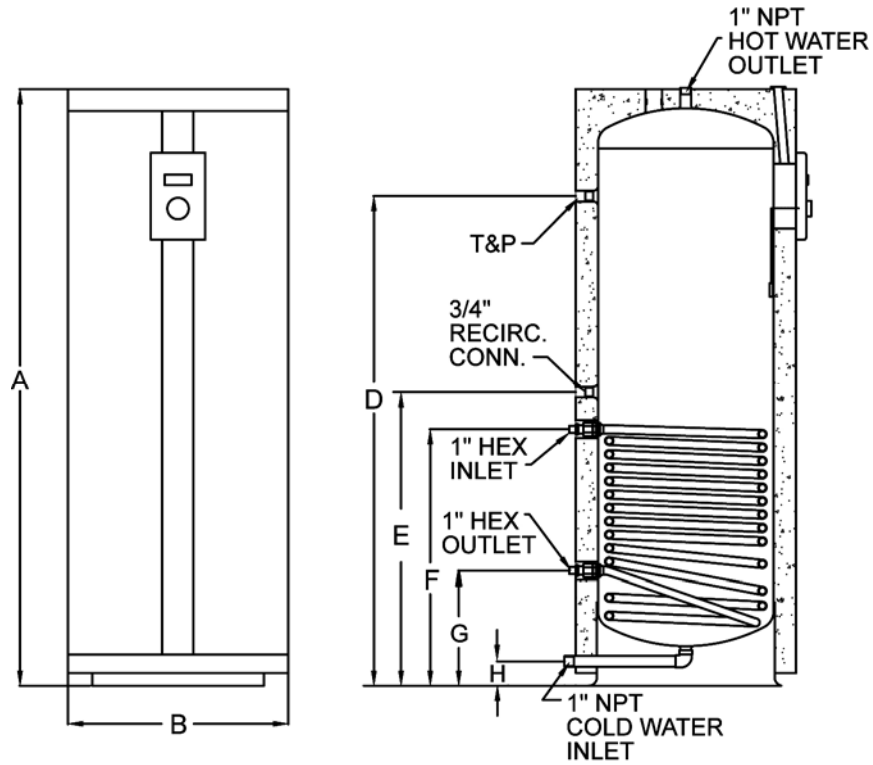

Stainless Steel Indirect				A	B	D	E	F	G	H	
Model Number	Gallon Capacity	1st Hour Rating @ 140°F	1st Hour Rating @ 115°F	Height	Diameter	T&P	Return	HEX Inlet	HEX Outlet	Cold Water Inlet	Shipping Weight (lbs)
SSS030	32	142	189	37 1/2	23 1/4	27 3/4	22 3/4	19	12 1/4	2 3/4	110
SSS040	42	150	195	47 1/4	23 1/4	41	24 1/2	20 1/2	12 1/4	2 3/4	135
SSS060	60	273	360	63	23 1/4	56 3/4	31	27	12 1/4	2 3/4	155
SSS085	90	501	667	66 1/4	27 1/4	59 1/4	39 3/4	36 1/2	13 1/2	3 1/2	245
SSS120	119	529	695	82 1/4	27 1/4	75	39 3/4	36 1/2	13 1/2	3 1/2	285

Notes:

Water connections are 1" NPT

Heat Exchanger connections are 1" female NPT

Performance data is based on manufacturer's test results.

All ratings are based on 180°F boiler water temperature, 50°F potable water temperature and an approximate boiler output of 220,000 Btu/Hr.

PRE-INSTALLATION

INSPECT SHIPMENT carefully for any signs of damage. If damage is noted, do not install the product. Contact the shipper or manufacturer listed on rating plate. All equipment is carefully manufactured, inspected, and packed. Our responsibility ceases upon delivery of the packaged heater to the carrier in good condition.

NOTE: Any claims for damage or shortage in shipment must be filed immediately against the carrier by the consignee.

LOCATION

CAUTION

This water heater must be located in an area where leakage of the tank, water line connections, or the temperature and pressure relief valve will not result in damage to the area adjacent to the water heater or to lower floors of the structure. When such locations cannot be avoided, a suitable drain pan must be installed under the water heater. The drain pan depth must be suitable for draining and collecting water, and have a minimum length and width of at least four (4) inches measured from the jacket of the water heater. The drain pan, as described above, can be purchased from your plumbing professional. The drain pan must be piped to an adequate drain. The piping must be at least ¾" in diameter and pitched for proper drainage.

Clearance from Combustible Materials

0" –Top, 0" –Sides, 0" –Front, 0" –Rear

Recommended Service Clearances

12" –Top, 4" –Sides, 16" –Front, 0" –Rear

Appliance Location

1. Boiler Location – Locate the Indirect Water Heater as close to the boiler as practical.
2. Fixture Locations – For fastest delivery of hot water, place the Indirect Water Heater close to points of use.

Additional Recommended Components

1. Shut-off Valves – Allows isolation of water heater from domestic water system and/or boiler system during service.
2. Unions – Allows water heater movement during service if adequate clearance cannot be provided.
3. Thermal Expansion Tank – If the water heater is installed in a closed water supply system, such as one having a back-flow preventor in the cold water line, provide thermal expansion control. Contact the water supplier or local plumbing inspector for additional information.

WATER CONNECTIONS

1. BEFORE PROCEEDING WITH THE INSTALLATION, CLOSE THE MAIN WATER SUPPLY VALVE.

After shutting off the main water supply, open a faucet to relieve the water line pressure to prevent any water from leaking out of the pipes while making the water connections to the water heater. After the pressure has been relieved, close the faucet. The COLD water inlet and HOT water outlet are identified on the water heater. Make the proper plumbing connections between the water heater and the plumbing system to the house. Install a shut-off valve in the cold water supply line.

2. If this water heater is installed in a closed water supply system, such as one having a back-flow preventor in the cold water supply, provisions must be made to control thermal expansion. **DO NOT** operate this water heater in a closed system without provisions for controlling thermal expansion. Warranties do not cover damages from thermal expansions such as pressure bulges and/or deformities. A properly sized expansion tank will alleviate most problems. Your water supplier or local plumbing inspector should be contacted on how to control this situation.

3. After installation of the water lines, open the main water supply valve and fill the water heater. While the water heater is filling, open several hot water faucets to allow air to escape from the water system. When steady streams of water flow through the faucets, close them and check all water connections for possible leaks.

4. NEVER OPERATE THE WATER HEATER WITHOUT FIRST BEING CERTAIN THAT IT IS FILLED WITH WATER.

TEMPERATURE AND PRESSURE RELIEF VALVE

WARNING

Keep clear of the combination temperature and pressure relief valve discharge line outlet. The discharge may be hot enough to cause scald injury. The water is under pressure and may splash. For protection against excessive temperatures and pressure, install temperature and pressure protective equipment required by local codes, but not less than a combination temperature and pressure relief valve certified by a nationally recognized testing laboratory that maintains periodic inspection of production of listed equipment or materials as meeting the requirements of the Standard for *Relief Valves and Automatic Gas Shutoff Devices for Hot Water Supply Systems, ANSI Z21.22* and the Standard *CAN1-4.4 Temperature, Pressure, Temperature and Pressure Relief Valves and Vacuum Relief Valves*. The combination temperature and pressure relief valve must be marked with a maximum set pressure not to exceed the maximum working pressure of the water heater. The combination temperature and pressure relief valve must also have an hourly rated temperature steam BTU discharge capacity not less than the hourly rating of the water heater. The supplied combination temperature and pressure relief valve, when properly installed and unrestricted, will discharge the maximum input produced by a 200°F (93°C) boiler supply temperature. A lower boiler supply temperature will reduce the input required to be discharged in the event of excessive potable water temperatures. Install the combination temperature and pressure relief valve into the opening provided and marked for this purpose on the water heater. Some models may already be equipped or supplied with a temperature and pressure relief valve. Verify that the combination temperature and pressure relief valve complies with local codes. If the temperature and pressure relief valve does not comply with local codes, replace it with one that does.

WARNING

Install a discharge line so that water discharged from the temperature and pressure relief valve will exit within six (6) inches above, or any distance below, the structural floor and cannot contact any live electrical part. The discharge line is to be installed to allow for complete drainage of both the temperature and pressure relief valve and the discharge line. The discharge opening must not be subjected to blockage or freezing. DO NOT thread, plug, or cap the discharge line. It is recommended that a minimum clearance of four (4) inches be provided on the side of the water heater for servicing and maintenance of the combination temperature and pressure relief valve. Do not place a valve between the combination temperature and pressure relief valve and the tank!

BOILER CONNECTIONS

The Indirect connection labeled "BOILER WATER OUT" should be piped to the boiler water return piping as close to the boiler as possible and after any flow control or check valves in the space heating return piping. The use of a union and a shut-off valve is recommended. The use of a flow control or check valve is required to prevent back flow through the water heater during operation of the space heating system. Pipe and fittings between the boiler and Indirect should be $\frac{3}{4}$ " diameter or larger.

The Indirect connection labeled "BOILER WATER IN" should be piped to the boiler water supply piping. Mount the circulator making sure the flow arrow points toward the water heater. The use of Shut-off valves and unions are recommended for future service convenience. The use of an air separator and vent is recommended to eliminate air in the system. Pipe and fittings between the boiler and Single-wall Indirect must be $\frac{3}{4}$ " diameter or larger.

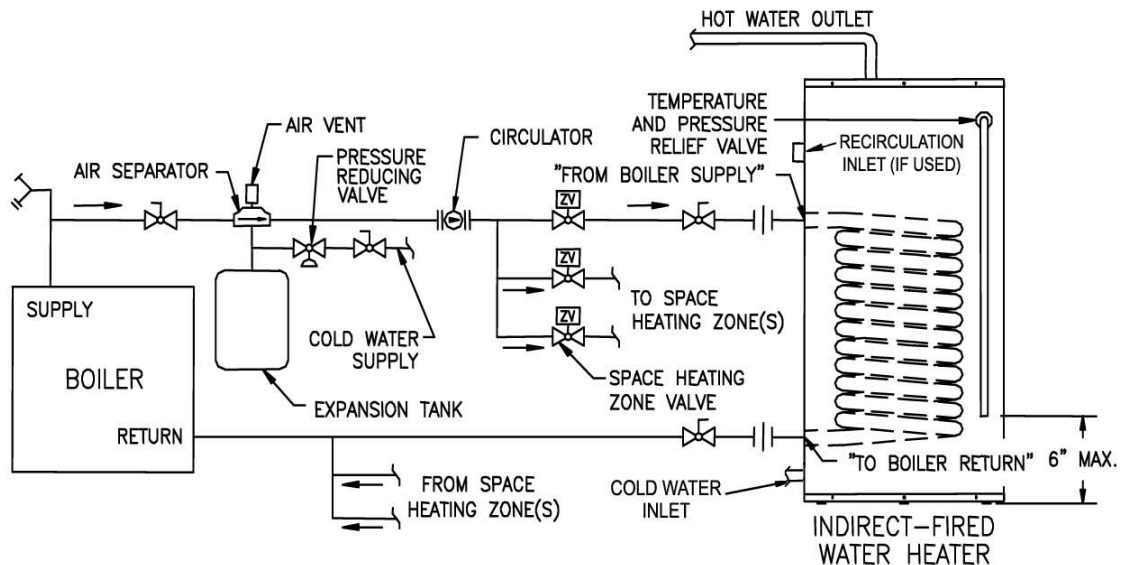

Figure 1. – System with Zone Valves

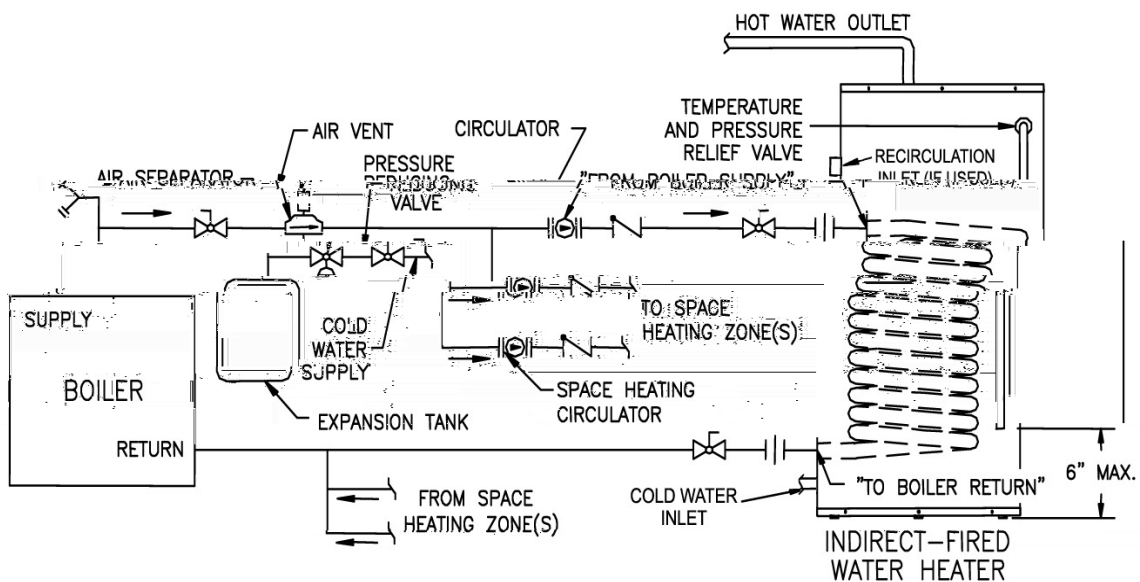

Figure 2. – System with Circulators

BOILER SYSTEM

1. On new boiler installations, do not purge the boiler or space heating system through the water heater. During any boiler or space heating system flushing, cleaning, or purging, the water heater should be isolated to avoid possible attack on the coil by chemical additives.
2. Purge air from boiler/water heater piping.
3. Check system for leaks. Repair as necessary.

ELECTRICAL CONNECTIONS

Install electric wiring in accordance with National Electric Code or the Canadian Electrical Code and local regulations. See the boiler's installation manual for wiring diagrams. The Indirect is equipped with an adjustable temperature control. Once electrical connections are complete, secure the control cover back in place. **AT NO TIME SHOULD WATER HEATER OPERATION TAKE PLACE WITHOUT THE COVER ON THE CONTROL.**

INSTALLING THEROMSTAT WIRING

1. Remove (4) screws from cover to remove front control panel.
2. Feed 24 volt wire from boiler control through the opening on the top pan labeled "thermostat connection. Install female ¼" connectors on the wiring and connect to the (2) two ¼" spade terminals on the thermostat.
3. Make sure all wiring is safely inside the junction box and reinstall the front control panel cover.

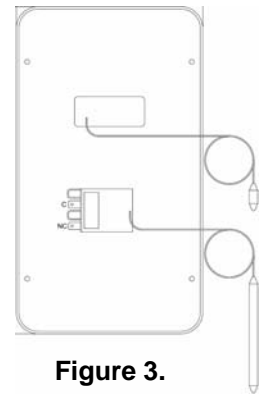

DANGER

Positively assure all electrical connections are unpowered before attempting installation or service of electrical components or connections of the water heater or building. Lock out all electrical boxes with padlock once power is turned off.

WARNING

When installed, the water heater must be electrically grounded in accordance with local codes or, in the absence of local codes, with the National Electrical Code, ANSI/NFPA 70, and /or the CSA C22.1 Electric Code. Failure to properly wire electrical connections to the water heater may result in serious physical harm. Electrical power may be from more than one source. Make sure all power is off before attempting any electrical work.

WATER TEMPERATURE ADJUSTMENT

WARNING - SCALDING

This water heater can deliver scalding temperature water at any faucet in the system. Be careful whenever using hot water to avoid scalding injury. By setting the thermostat on this water heater to obtain an increased water temperature, you may create the potential for scald injury. To protect against injury, you should install an ASSE approved mixing valve (a device to limit the temperature of water to protect against scald injury via mixing hot and cold water supply) in the water system. This valve will reduce point of discharge temperature in branch supply lines. Such valves are available from the manufacturer of this water heater or a local plumbing supplier. Please consult with a plumbing professional.

1. The thermostat controls the maximum water temperature in the tank. The differential is a fixed 5°F with a 170°F maximum setting. See Approximate Time/Temperature Relationship guide to determine the safest water temperature for your applications.

2. For the most energy efficient operation, adjust the thermostat for the minimum water temperature necessary to meet domestic hot water needs. **IT IS NOT NECESSARY TO REMOVE THE COVER TO ADJUST THE TEMPERATURE SETTING. THE THERMOSTAT COVER SHOULD NEVER BE REMOVED WITHOUT ELECTRICITY BEING FIRST DISCONNECTED.**

3. After the water heater completes a heat-up cycle, check the water temperature at a faucet. Allow enough water to flow to ensure that the water temperature reflects the tank temperature. Adjust the water heater's temperature setting as necessary.

a. Adjusting to a lower temperature setting will not immediately affect water temperature. Draw sufficient water or allow the water heater to sit until a heat-up cycle is initiated. Repeat step 3.

b. Adjusting to a higher temperature may not immediately affect water temperature. If a heat up cycle begins, return to step 3. If a heat-up cycle does not begin, draw sufficient water or allow the water heater to sit until a heat-up cycle is initiated. Repeat step 3.

APPROXIMATE TIME/TEMPERATURE RELATIONSHIPS IN SCALDS

120°F More than 5 minutes

125°F 1 ½ to 2 minutes

130°F About 30 seconds

135°F About 10 seconds

140°F Less than 5 seconds

145°F Less than 3 seconds

150°F About 1 ½ seconds

155°F About 1 second

CAUTION

Before manually operating the valve, make sure that a drain line has been attached to the valve to direct the discharge to an open drain. Failure to take this precaution could mean contact with extremely hot water discharging from the valve during this checking operation.

OPERATING INSTRUCTIONS

BOILER SYSTEM START-UP

Follow boiler installation instructions to place boiler in operation.

SEQUENCE OF OPERATIONS

1. Thermostat senses stored water temperature below desired setting.

a. Normally open contacts close to interrupt space heating.

2. Thermostat senses stored water temperature at desired setting.

a. Normally open contacts open, returning boiler control to space heating.

MAINTENANCE

The Indirect Water Heater is intended to provide a service life of many years. Components that require service, however, may be subject to failure. Failure to use the correct procedures or parts in these circumstances may make the water heater unsafe. The owner should arrange to have the following inspections and simple maintenance procedure performed by qualified service personnel at the frequencies suggested.

1. Boiler and Domestic Water Piping (Annual) – Check all piping for signs of leakage at joints, unions, and shut-off valves. Repair as needed.

2. Temperature-Pressure Relief Valve (Annual) - The temperature-pressure relief valve should be checked to ensure that it is in operating condition. To check the relief valve, lift the lever at the end of the valve several times. The valve should seat properly and operate freely. If water does not flow, remove and inspect for obstructions or corrosion. Replace with a new valve of the recommended size as necessary. Do not attempt to repair the valve, as this could result in improper operation and a tank explosion. In areas with poor water conditions, it may be necessary to inspect the temperature-pressure relief valve more often than once a year. If the temperature–pressure relief valve on the heater discharges periodically or continuously, it may be due to thermal expansion of water in a closed water supply system, or it may be due to a faulty relief valve. Thermal expansion is the normal response of water when it is heated. In a closed system, thermal expansion will cause the system pressure to build until the relief valve actuation pressure is equaled. Then the relief valve will open, allowing some water to escape, slightly lowering the pressure. Contact your water supplier or local plumbing inspector on how to control this situation.

ABOVE ALL, DO NOT PLUG THE TEMPERATURE AND PRESSURE RELIEF VALVE. THIS IS NOT A SOLUTION AND CAN CREATE A HAZARDOUS SITUATION.

3. Sediment (Annual, but harsh water quality may dictate more frequent service) - Depending on water conditions, a varying amount of sediment may collect in the tank. Levels requiring service are indicated by a small temperature difference in the supply and return lines (See also “Scale” below). Repeated flushing usually clears such material. As a preventive measure, water should be drawn from the tank at the drain valve until it runs clear.

4. Scale (Annual) - Hard water may cause scale to build-up on the outside of the heat exchanger coil. A water softener will prevent this problem (See also “Sediment” above). Symptoms would include reduced recovery capacity or reduced temperature differential between boiler supply and return lines. Repeated flushing should resolve the problem.

NOTES: _____



Lochinvar[®]
High Efficiency Water Heaters, Boilers and Pool Heaters
300 Maddox Simpson Parkway
Lebanon, TN 37090
615-889-8900
www.Lochinvar.com