



US007356361B1

(12) **United States Patent**
Hawkins et al.

(10) **Patent No.:** **US 7,356,361 B1**
(45) **Date of Patent:** **Apr. 8, 2008**

(54) **HAND-HELD DEVICE**

(75) Inventors: **Jeffrey C Hawkins**, Redwood City, CA (US); **Peter N Skillman**, San Carlos, CA (US); **William B Rees**, Menlo Park, CA (US); **Robert Y Haitani**, Menlo Park, CA (US); **Michael A Yurochko**, Los Gatos, CA (US); **Edward T Colligan**, San Jose, CA (US)

5,075,684 A	12/1991	DeLuca	
5,127,041 A	6/1992	O'Sullivan	379/59
RE34,034 E	8/1992	O'Sullivan	375/59
5,189,632 A	2/1993	Paajanen et al.	364/705.05
5,249,218 A	9/1993	Sainton	375/59
5,335,276 A	8/1994	Thompson et al.	380/21

(Continued)

FOREIGN PATENT DOCUMENTS

CA 2187050 5/1997

(Continued)

(73) Assignee: **Palm, Inc.**, Sunnyvale, CA (US)

(*) Notice: Subject to any disclaimer, the term of this patent is extended or adjusted under 35 U.S.C. 154(b) by 768 days.

OTHER PUBLICATIONS

Motorola Model V100 User's Guide, pp. 1, 2, 17-19, 33.*

(Continued)

(21) Appl. No.: **09/976,841**

(22) Filed: **Oct. 13, 2001**

Related U.S. Application Data

(60) Provisional application No. 60/297,817, filed on Jun. 11, 2001.

(51) **Int. Cl.**
H04M 1/00 (2006.01)

(52) **U.S. Cl.** **455/575.1**; 379/368

(58) **Field of Classification Search** D14/399-401; 379/368, 453.07; 178/17 A, 17 C; 341/23; 708/145; 455/575.1

See application file for complete search history.

(56) **References Cited**

U.S. PATENT DOCUMENTS

3,573,376 A *	4/1971	Bartlett et al.	379/93.26
4,545,023 A	10/1985	Mizzi	364/709
4,799,254 A *	1/1989	Dayton et al.	379/93.26
4,931,783 A	6/1990	Atkinson	
4,972,457 A	11/1990	O'Sullivan	379/59
5,010,547 A	4/1991	Johnson et al.	

(57) **ABSTRACT**

A hand-held device that provides communication services and symbol processing is described. The device includes a case having a front side comprising a display and a lid having a transparent portion through which the display can be seen in a lid-closed state. In one version, the hand-held device comprises a QWERTY keyboard including an arrangement of digits as in a touch-tone telephone keypad arrangement. In another version, the display includes a handwriting area for data entry using a stylus or other screen data entry device. In a closed position, the lid extends over the display and the keyboard, leaving another user input device physically accessible to touch for receiving input wherein the device performs processing responsive to receiving input from the physically accessible user input device in the lid closed state.

70 Claims, 13 Drawing Sheets

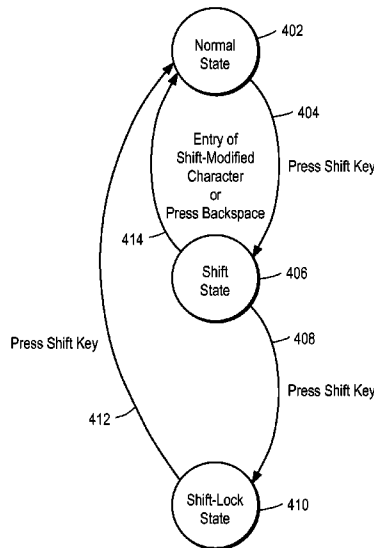

U.S. PATENT DOCUMENTS

5,353,334 A	10/1994	O'Sullivan	379/59
5,367,563 A	11/1994	Sainton	379/98
D354,478 S	1/1995	Miyahara	D14/100
5,394,140 A	2/1995	Wong et al.	
D359,734 S	6/1995	Nagele et al.	D14/138
5,430,436 A	7/1995	Fennell	
5,436,960 A	7/1995	Campana, Jr. et al.	379/58
5,438,611 A	8/1995	Campana, Jr. et al.	379/58
5,446,759 A	8/1995	Campana, Jr. et al.	375/267
5,479,472 A	12/1995	Campana, Jr. et al.	379/58
5,485,373 A	1/1996	Davis et al.	
5,496,992 A	3/1996	Madan et al.	
5,550,715 A	8/1996	Hawkins	362/31
5,584,054 A	12/1996	Tyneski et al.	455/89
5,594,640 A	1/1997	Capps et al.	
5,612,682 A	3/1997	DeLuca et al.	
5,625,670 A	4/1997	Campana, Jr. et al.	379/58
5,631,946 A	5/1997	Campana, Jr. et al.	379/58
5,640,146 A	6/1997	Campana, Jr. et al.	340/573
5,640,444 A	6/1997	O'Sullivan	379/59
5,650,769 A	7/1997	Campana, Jr. et al.	340/573
5,650,776 A	7/1997	Mitchell et al.	
D385,875 S	11/1997	Harris et al.	D14/138
D386,497 S	11/1997	Huslig et al.	D14/191
5,694,428 A	12/1997	Campana, Jr. et al.	375/260
5,710,798 A	1/1998	Campana, Jr. et al.	375/347
5,714,937 A	2/1998	Campana, Jr. et al.	340/573
5,717,725 A	2/1998	Campana, Jr. et al.	375/347
5,722,059 A	2/1998	Campana, Jr. et al.	455/226.2
5,722,064 A	2/1998	Campana, Jr. et al.	455/351
D393,856 S	4/1998	Lee et al.	D14/138
5,742,644 A	4/1998	Campana, Jr. et al.	375/316
5,745,532 A	4/1998	Campana, Jr. et al.	375/347
5,751,773 A	5/1998	Campana, Jr. et al.	375/346
D395,300 S	6/1998	Yamazaki et al.	D14/138
5,761,621 A	6/1998	Sainton	455/453
5,797,089 A	8/1998	Nguyen	
5,797,098 A	8/1998	Schroeder et al.	
5,798,759 A	8/1998	Dahl	
5,805,633 A	9/1998	Uddenfeldt	375/202
5,812,117 A	9/1998	Moon	345/169
5,819,172 A	10/1998	Campana, Jr. et al.	455/412
5,825,675 A	10/1998	Want et al.	364/708.1
5,854,985 A	12/1998	Sainton et al.	455/553
5,864,805 A	1/1999	Chen et al.	
5,884,323 A	3/1999	Hawkins et al.	
D408,021 S	4/1999	Haitani et al.	D14/100
D408,030 S	4/1999	Richards et al.	D14/138
D409,185 S	5/1999	Kawashima	D14/138
D410,486 S	6/1999	Takahata et al.	D18/2
5,926,170 A *	7/1999	Oba	345/160
5,938,772 A *	8/1999	Welch	713/320
5,949,408 A	9/1999	Kang et al.	
5,958,006 A	9/1999	Eggleston et al.	
D416,001 S	11/1999	Tal et al.	D14/100
D416,256 S	11/1999	Griffin et al.	D14/191
5,983,073 A	11/1999	Ditzik	
5,990,872 A	11/1999	Jorgenson et al.	345/168
6,000,000 A	12/1999	Hawkins et al.	
6,005,496 A *	12/1999	Hargreaves et al.	341/22
6,006,274 A	12/1999	Hawkins et al.	
6,022,156 A *	2/2000	Blish	400/472
D421,744 S	3/2000	Ono	D14/100
6,043,760 A	3/2000	Laakkonen	
D423,468 S	4/2000	Jenkins	D14/100
6,049,796 A *	4/2000	Siitonen et al.	707/3
6,052,735 A	4/2000	Ulrich et al.	
6,058,304 A	5/2000	Callighan et al.	455/422
6,067,451 A	5/2000	Campana, Jr. et al.	455/412
D432,099 S	10/2000	Loh et al.	D14/100
D432,535 S	10/2000	Loh et al.	D14/345

D433,016 S	10/2000	Matsuda et al.	D14/345
6,134,453 A	10/2000	Sainton et al.	455/553
6,141,540 A	10/2000	Richards et al.	455/90
6,157,630 A	12/2000	Adler et al.	
6,160,926 A	12/2000	Dow et al.	
6,169,485 B1	1/2001	Campana, Jr. et al.	340/573
6,188,789 B1	2/2001	Marianetti, II et al.	382/189
D439,232 S	3/2001	Ledingham et al.	D14/144
6,198,783 B1	3/2001	Campana, Jr. et al.	375/346
6,204,848 B1	3/2001	Nowlan et al.	
RE37,141 E	4/2001	O'Sullivan	455/557
D440,959 S	4/2001	Wolf et al.	D14/191
6,219,694 B1	4/2001	Lazaridis et al.	709/206
D442,156 S	5/2001	Lee	D14/138
D443,865 S	6/2001	Kim	D14/138
D446,199 S	8/2001	Xu et al.	D14/138
6,272,190 B1	8/2001	Campana, Jr. et al.	375/345
6,278,442 B1	8/2001	Griffin et al.	345/169
6,295,460 B1	9/2001	Nagel et al.	455/557
6,297,795 B1	10/2001	Kato et al.	
6,310,926 B1	10/2001	Tore	
D450,307 S	11/2001	Xu et al.	D14/138
6,317,592 B1	11/2001	Campana, Jr. et al.	455/412
6,330,618 B1	12/2001	Hawkins et al.	
D454,349 S	3/2002	Makidera et al.	D14/343
D455,135 S	4/2002	Hyun	D14/138
6,377,685 B1 *	4/2002	Krishnan	379/433.07
D456,805 S	5/2002	Ono et al.	D14/342
6,396,482 B1	5/2002	Griffin et al.	
6,397,078 B1	5/2002	Kim	
6,421,707 B1	7/2002	Miller et al.	
6,452,588 B2	9/2002	Griffin et al.	
6,477,482 B1	11/2002	Maupin et al.	
6,489,950 B1 *	12/2002	Griffin et al.	345/168
6,587,132 B1 *	7/2003	Smethers	345/160
6,611,254 B1	8/2003	Griffin et al.	
6,611,255 B2	8/2003	Griffin et al.	
6,611,697 B1	8/2003	Ewing et al.	
6,662,244 B1	12/2003	Takahashi	
6,665,173 B2	12/2003	Brandenberg et al.	
6,725,060 B1	4/2004	Chhatriwala et al.	
6,728,786 B2	4/2004	Hawkins et al.	
6,857,105 B1	2/2005	Fox et al.	
6,867,763 B2	3/2005	Griffin et al.	
6,873,317 B1	3/2005	Griffin et al.	
6,874,011 B1	3/2005	Spielman et al.	
6,891,529 B2	5/2005	Ladouceur et al.	
6,919,879 B2	7/2005	Griffin et al.	
6,934,558 B1	8/2005	Sainton et al.	
6,957,397 B1	10/2005	Hawkins	
6,961,584 B2	11/2005	Leedom, Jr.	
7,054,441 B2	5/2006	Pletikosa	
7,061,403 B2	6/2006	Fux	
7,136,897 B1	11/2006	Raghunandan	
RE39,427 E	12/2006	O'Sullivan	
7,155,521 B2	12/2006	Lahti et al.	
2001/0027121 A1	10/2001	Boesen	
2002/0036623 A1	3/2002	Kano	
2002/0058533 A1	5/2002	Nagel et al.	
2002/0063738 A1	5/2002	Chung	
2002/0086702 A1	7/2002	Lai et al.	
2002/0090934 A1	7/2002	Mitchelmore	
2002/0097227 A1	7/2002	Chu et al.	
2003/0123627 A1	7/2003	Pinard et al.	
2004/0047505 A1	3/2004	Ghassabian	

FOREIGN PATENT DOCUMENTS

EP	0 149 762	7/1985
EP	0 813 328 A2	12/1997
EP	0 840 934 B1	4/1999
EP	933908 A2 *	8/1999
EP	1071029 A2	1/2001

WO	WO 94/10678	5/1994
WO	WO 94/16408	7/1994
WO	WO 96/01453	1/1996
WO	WO 00/65445	11/2000

OTHER PUBLICATIONS

Motorola Model 009 User's Guide, pp. 1, 3, 22, 23 80.*
 Motorola Model 009 "Let's Start" guide, pp. 1, 3, 11.*
 DiSabatino, J., Hands full of information, Computerworld, Nov. 6, 2000, p.68.*
 Palencher, J., New phones deliver PIM function, Twice, Oct. 9, 2000, p. 44.*
 Pinkerton, J., Wireless meets computing again, Dealerscope, Nov. 2000, pp. 34-35.*
 Orubeondo, A., The new shape of mobile communication, InfoWorld, Apr. 23, 2001, pp. 65-66.*
 Photograph of Motorola 009 from 3GNewsroom.com.*
 BlackBerry Handheld Users Guide, Sep. 7, 1999.
 BlackBerry Developer's Guide SDK User's Guide Version 2.0 (Data TAC), Jun. 12, 2000.
 BlackBerry Desktop Software Installation and Getting Started Guide, Feb. 5, 1999.
 BlackBerry Enterprise Server Software Installation and Getting Started Guide, Sep. 29, 1999.
 Compaq Product Information, *iPAQ Pocket PC Options*, [retrieved Nov. 13, 2001], retrieved from internet: www.compaq.com/products/handhelds.,
 Choi, H., *First Look: Samsung 1300 Cellphone/PDA*, retrieved from internet www.techtv.com, Mar. 28, 2001.
 Handspring Product Information: *VisorPhone The Springboard Module that Transforms your Visor into an Extraordinary Phone*, (2000).
 Handspring, *Sprint and Airprime Delivery First Wireless CDMA Phone and Data Module for the Handspring Visor*, [retrieved Aug. 6, 2001], retrieved from internet www.handspring/pr59.jhtml.
 Handspring VisorPhone Module User Guide, (2000-2001).
 U.S. Appl. No. 07/831,671, Claims 25-55 only.
 U.S. Appl. No. 09/670,696, Claims 25-46 only.
 U.S. Appl. No. 09/813,165, Claims 24-29 only.
 IBM Technical Disclosure Bulletin: *SimpleUser Interface to a Cellular Telephone*, Oct. 1995, pp. 349-350, [retrieved Jul. 5, 2001], retrieved from internet.
 IBM Technical Disclosure Bulletin: *Inexpensive Personal Digital Assistant*, Apr. 1995, pp. 525-526, [retrieved Jul. 5, 2001], retrieved from internet.
 Kyocera's Smartphone Series, retrieved from internet www.kyocera-wireless.com, 2001.
 Mossberg, W., *Samsung Embeds Cellphone Inside Palm in New 1300 Device*, Aug. 30, 2001, [retrieved Oct. 26, 2001], retrieved from internet http://www.ptech.wsj.com/archive/ptech-20010830.html.
 Newspaper Article: *Ways to Escape Multiple-Remote Hell*, San Jose Mercury News, Jun. 14, 2001.
 Nokia 9110 Accessories Quick Guide Instruction Manual, 1999.
 Sprint PCS User Guide—Samsung Model SCH-8500, 1999.
 Tam, P., "Palm, Motorola to Make PDA Cell Phones", Sep. 25, 2000, [retrieved Jun. 19, 2001], retrieved from internet http://www.zdnet.com/zdnn/stories/news/0,4586,2631800,00.html.
 Technical White Paper BlackBerry Enterprise Edition for Microsoft Exchange, Version 2.1, (1999-2001).
 Technical White Paper BlackBerry Enterprise Server for Microsoft Exchange, Version 2.1, (1997-2001).
 TUCOWS PDA Phone GSM Dailer: GSM Dailer 1.0, Nov. 30, 2000, [retrieved Jun. 19, 2001], retrieved from internet http://pds.rep.net/pe/pocket/preview 154208.html.

U.S. Appl. No. 09/835,464, Claims 1-6 only.
 U.S. Appl. No. 09/953,211, Claims 26-30 only.
 User's Guide, hp iPAQ Pocket PC h4000 Series, Document Part No. 343434-001, Aug. 2003, 141 pages.
 SyncML Website Introduction Page, SyncML Initiative LTD., [Retrieved on Oct. 24, 2002]. Retrieved from the internet: <URL: http://www.syncml.org/about-intro.html>, 2 pages.
 SyncML Sync Protocol [Retrieved on Dec. 7, 2000]. Retrieved from the internet: <URL:http://www.syncml.org/docs/syncml_protocol_v10_20001207.pdf>, 60 pages.
 SyncML Sync Protocol Version 1.0.1 [Retrieved on Aug. 15, 2001]. Retrieved from the internet: <URL:http://www.syncml.org/docs/syncml_protocol_v101_20010815.pdf>, 61 pages.
 Wireless Application Protocol, Service Loading, WAP-168-ServiceLoad-200110731-a, Version Jul. 31, 2001, 18 pages.
 Wireless Application Protocol, Service Indication, WAP-167-ServiceInd-200110731-a, Version Jul. 31, 2001, 28 pages.
 Wireless Application Protocol, Push Message, WAP-251-PushMessage-20010322-a, Version Mar. 22, 2001, 14 pages.
 Wireless Application Protocol, WAP-Sync-Spec, Data Synchronisation Specification, WAP-234-SYNC-20010530-a, Version May 30, 2001, 11 pages.
 Wireless Application Protocol, Wireless Application Protocol, Wireless Markup Language Specification Version 1.3, WAP WML, WAP-191-WML, Feb. 19, 2000, 110 pages.
 Basterfield, D., "The IBM PalmTop PC110," Jan. 30, 2000, pp. 1-3.
 BlackBerry Handheld Installation & Getting Started Guide, © 2002 Copyright by Research in Motion Limited, 295 Philip Street, Waterloo, Ontario, Canada N2L 3W8. Revised Feb. 27, 2003, pp. 39-41. (www.rim.net).
 Microsoft, "The Windows Interface an Application Design Guide," 1987, pp. 84-87, Figures 1-6.
 Motorola V60i Wireless Phone User Manual, Personal Communications Sector, Motorola, Inc., 600 North U.S. Highway 45, Libertyville, Illinois (www.motorola.com), pages 1 and 53. url=http://www.motorola.com/mdirect/manuals/v60i_TDMA_User_Manual_E.pdf.
 Motorola Series 60g Wireless Phone User Manual, © 2001 Motorola, Inc., published by the Personal Communications Sector, 600 North U.S. Highway 45, Libertyville, Illinois (www.motorola.com) pp. 1-3.
 Newton MessagePad Handbook, © 1994 Apple Computer, Inc., 1 Infinite Loop, Cupertino, CA, pp. 14-19, 22 and 23. (www.apple.com).
 Progue, D., "PalmPilot: The Ultimate Guide," O'Reilly, 2nd Edition, Chapter 1-4.
 SyncML Sync Protocol, version 1.0.1, 2001, pp. 1-61.
 United States Court of Appeals for the Federal Circuit: *Wireless Agents LLC v. Sony Ericsson Mobile Communications AB and Sony Ericsson Mobile Communications (USA), Inc.*, Decided Jul. 26, 2006, 7 pages.
 Filing of translation of European Patent (UK) under Section 77(6)(a), European patent no. 1218814, Apr. 9, 2003, 13 pages.
 Motorola V60i Wireless Phone User Manual, Personal Communications Sector, Motorola, Inc., 600 North U.S. Highway 45, Libertyville, Illinois (www.motorola.com), pages 1 and 53. url=http://www.motorola.com/mdirect/manuals/v60i_TDMA_User_Manual_E.pdf. no date.
 Progue, D., "PalmPilot: The Ultimate Guide," O'Reilly, 2nd Edition, Chapter 1-4. no date.

* cited by examiner

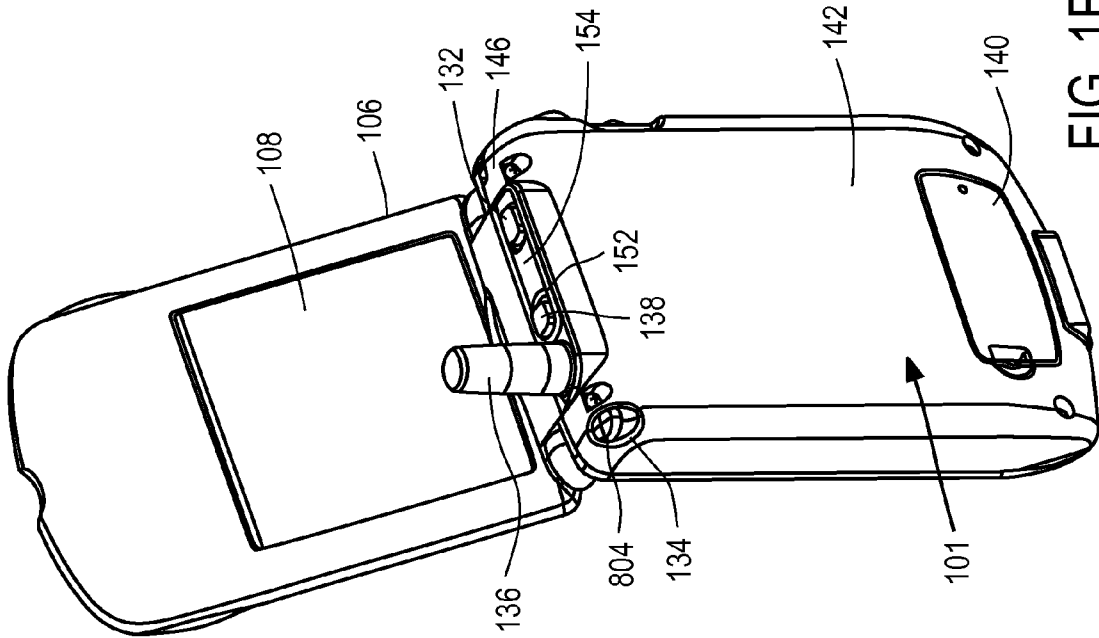

FIG. 1B

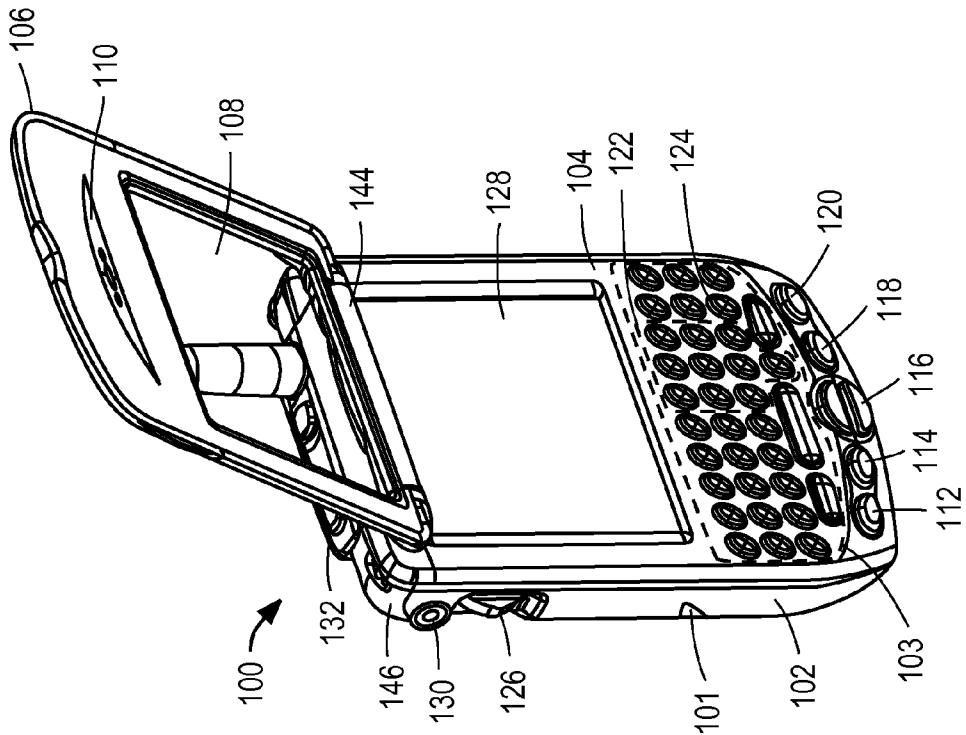

FIG. 1A

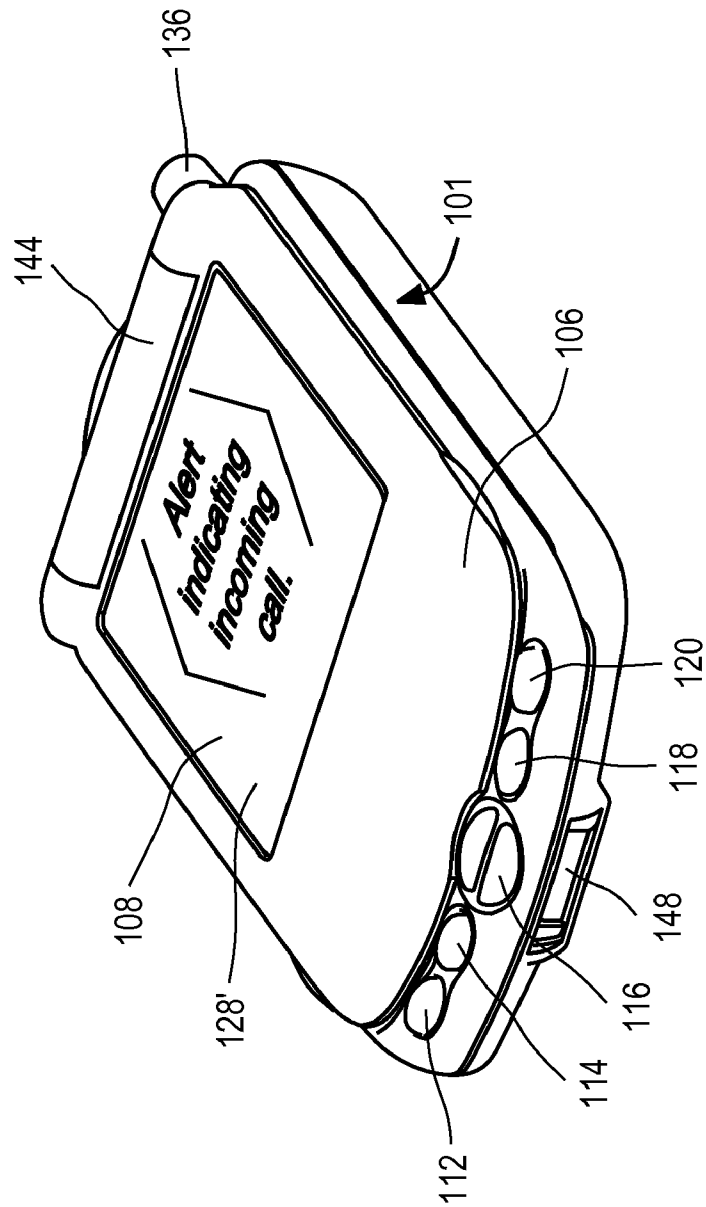

FIG. 1C

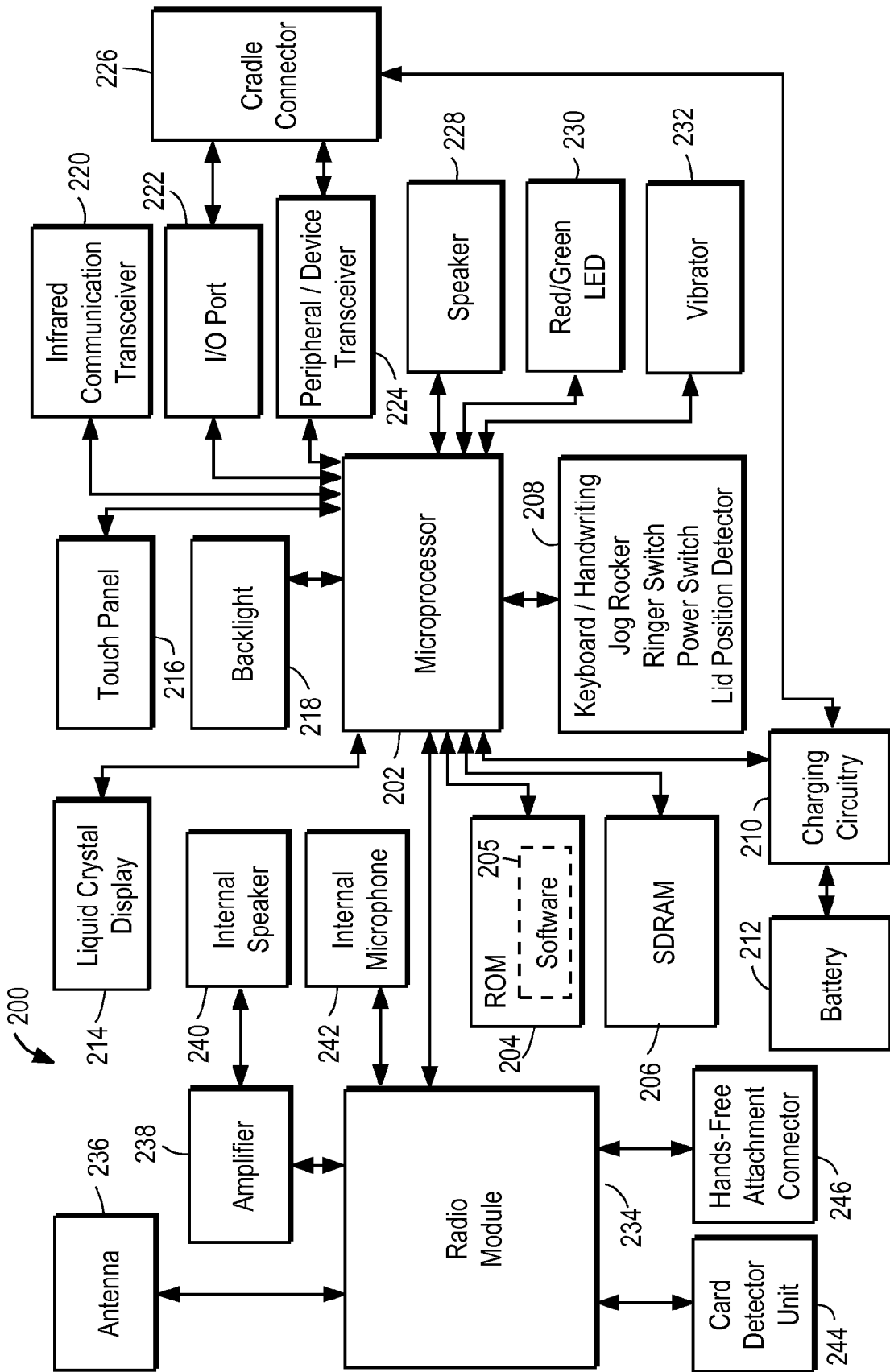

FIG. 2

Legend	
Shifted Symbol	Option Symbol
Normal Symbol	

<-one hardware key

FIG. 3A

Complete Keyboard Layout																			
Q	Cntrs	W	@	E	\$	R	/	T	*	Y	1	U	2	I	3	O	#	P	"
	q	w		e		r		t		y		u		i		o		p	
A	%	S	(D)	F	-	G	+	H	4	J	5	K	6	L	'	N/A	N/A
	a	s		d		f		g		h		j		k		l		Backspace	
N/A	N/A	Z	:	X	!	C	?	V	,	B	7	N	8	M	9	.		N/A	N/A
Option		z		x		c		v		b		n		m		.		Return	
N/A				Find		Tab				N/A			0		N/A			Launcher	
			Shift					Space				ListType				Menu/Command			

FIG. 3B

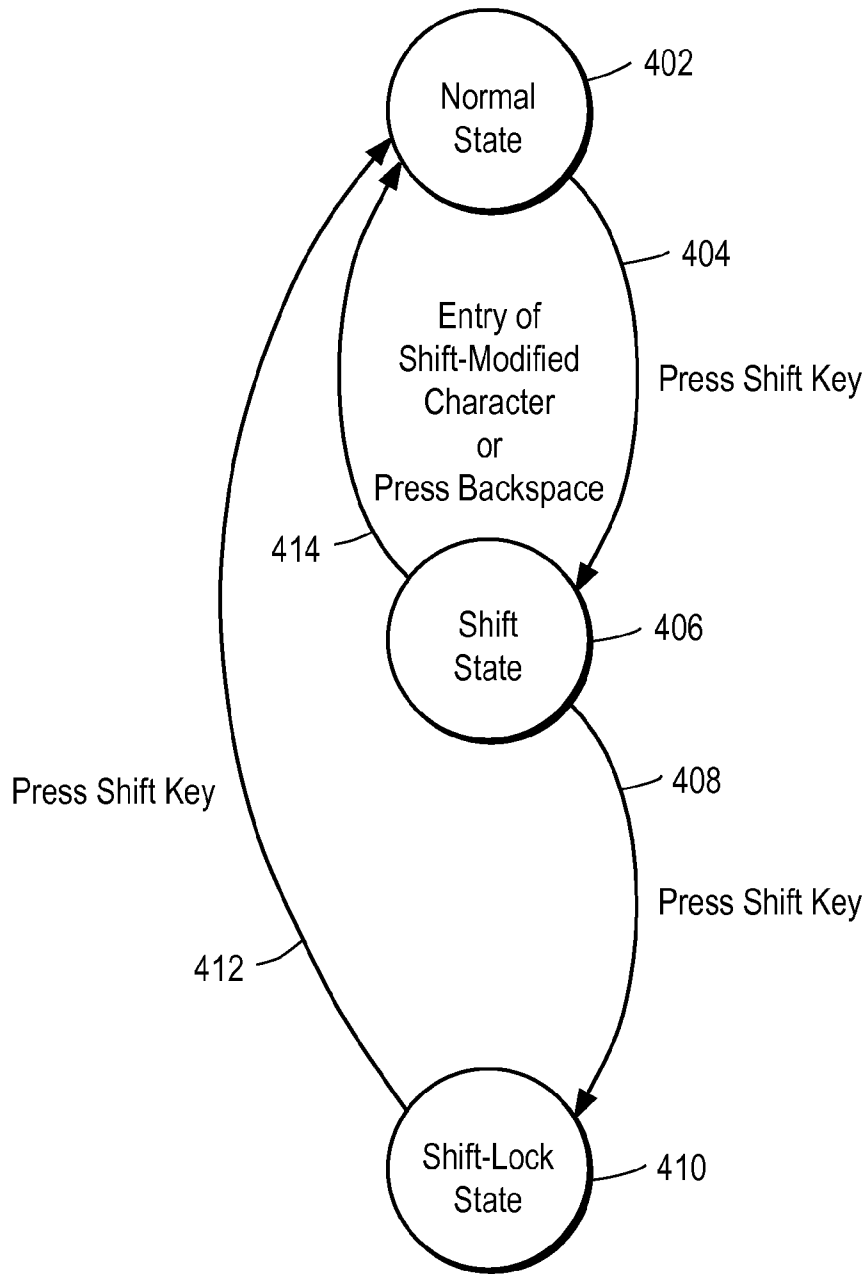

FIG. 4

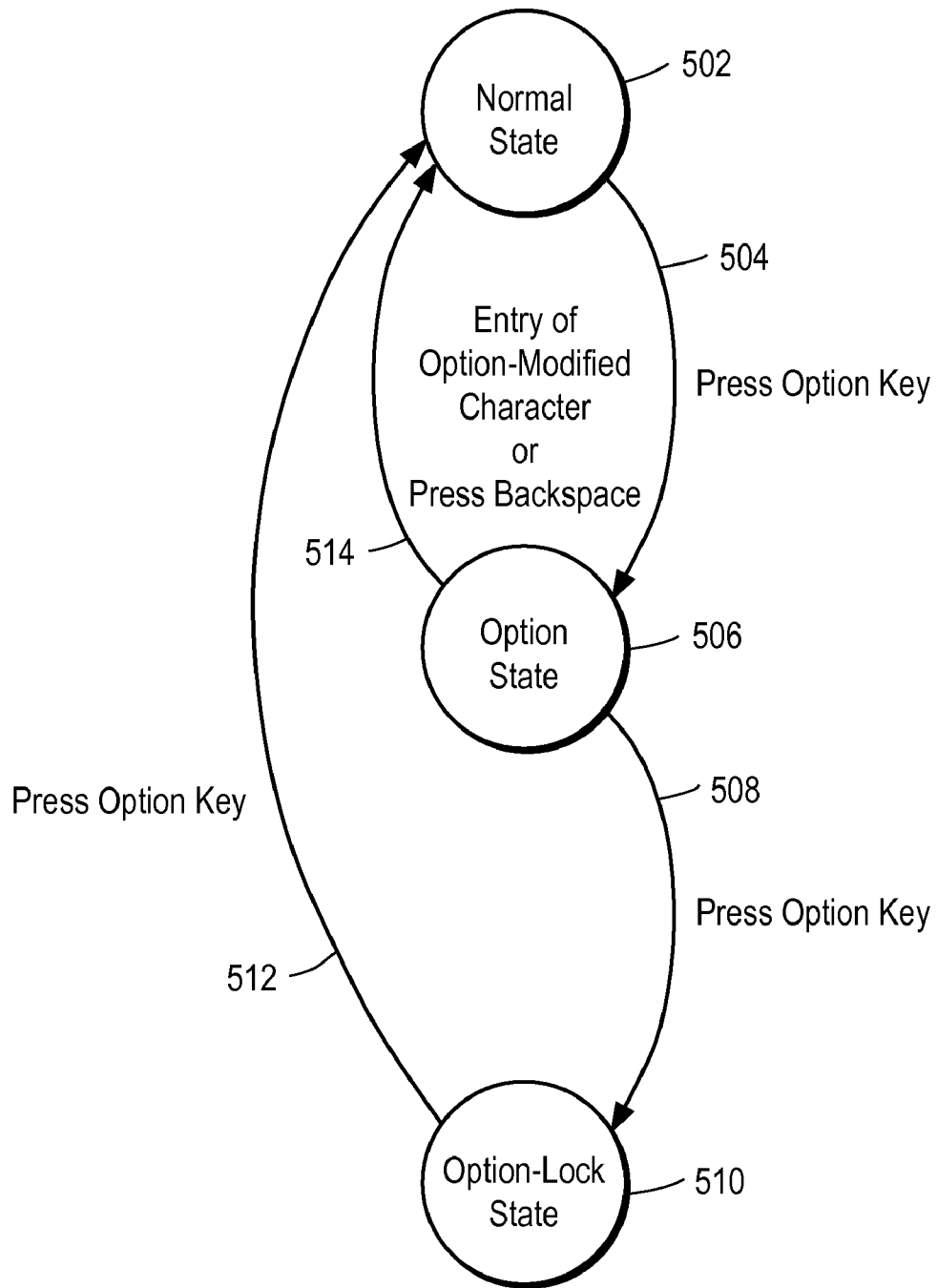

FIG. 5

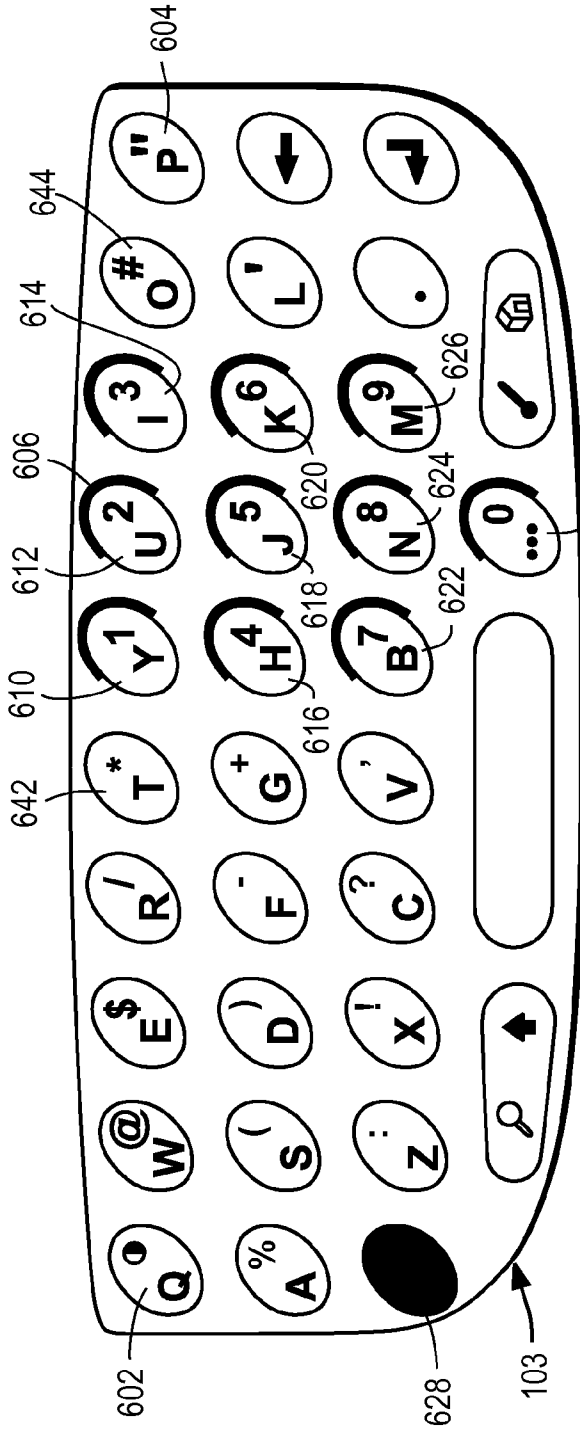

FIG. 6A

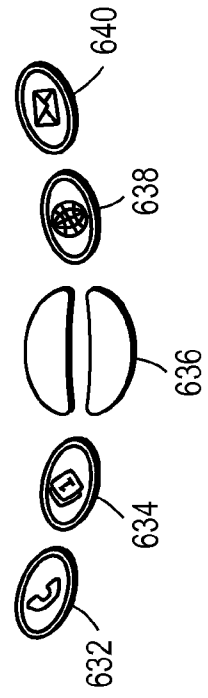

FIG. 6B

Action	Device Power Save State (including Active Headset Call)	Device Power-On-State				Other
		Incoming Call		Active Call		
		Within 1s of Notification	After 1s of Notification	No Headset	Headset	
Opening the Lid	Transitions device to device power-on-state; Launches an application assigned to the lid (e.g. telephone application, by default).	Nothing	Answers call	Not Applicable (e.g. Lid already is open)	Nothing	Nothing
Closing the Lid	Nothing	Nothing	Silences ring, Ignores call, Transitions Device to a Power-save-State.	Hangs Up, Transitions device to a device power-save-state.	Transitions device to a device power-save-state; Does not hang up the call.	Transitions device to a device power-save-state.

FIG. 7

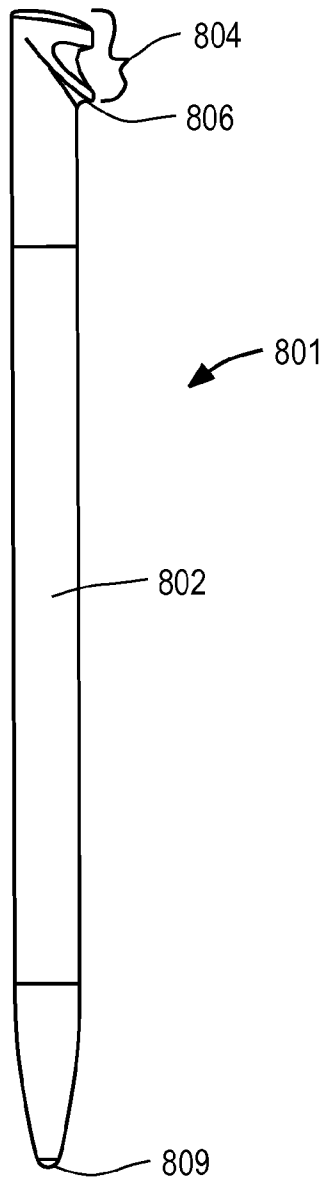

FIG. 8A

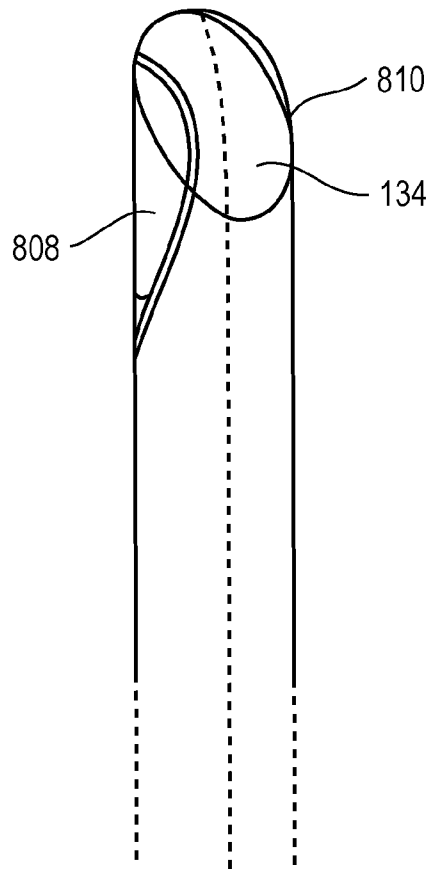

FIG. 8B

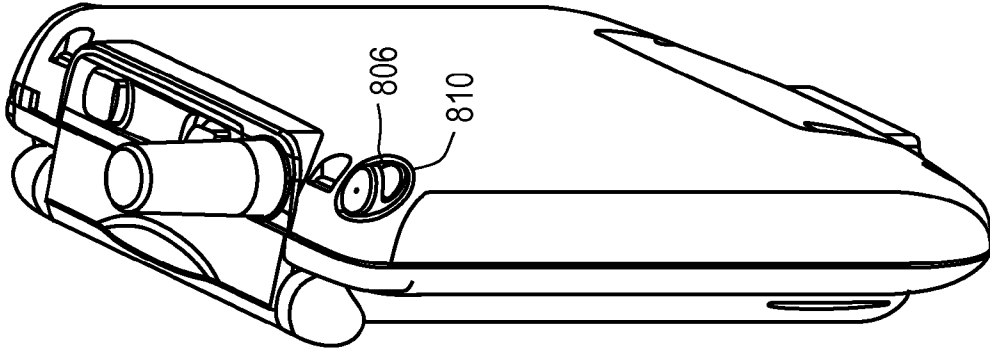

FIG. 8F

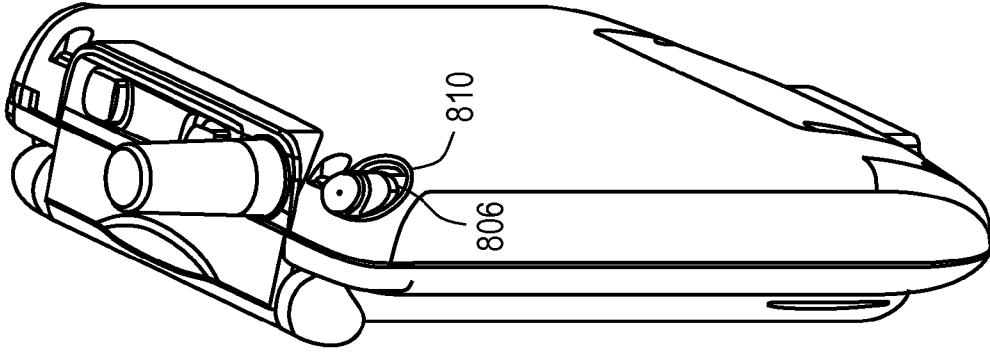

FIG. 8E

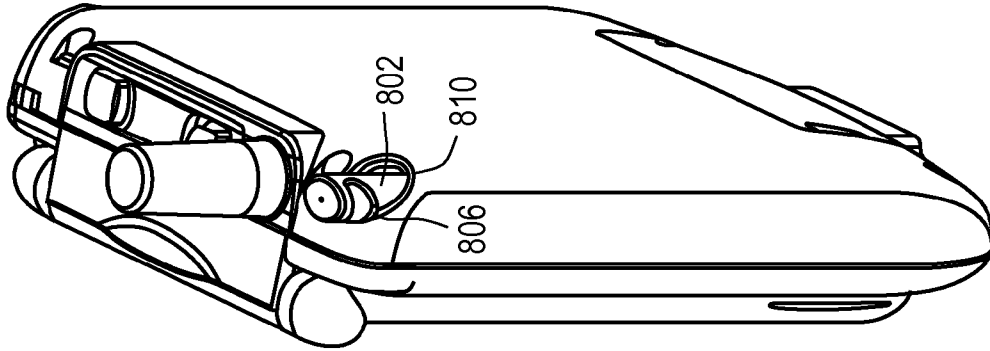

FIG. 8D

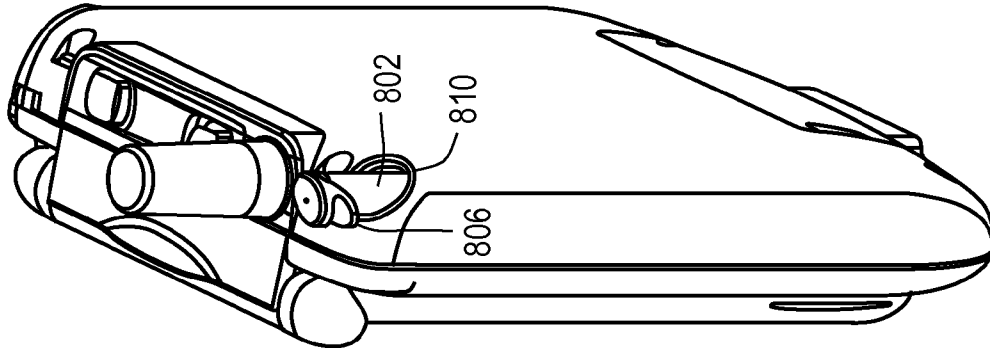

FIG. 8C

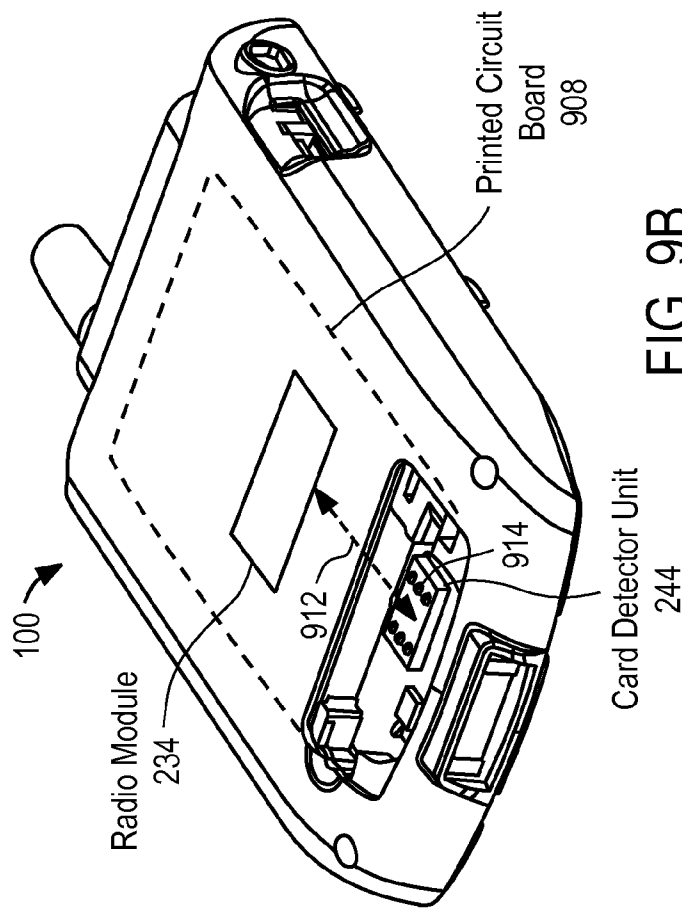

FIG. 9B

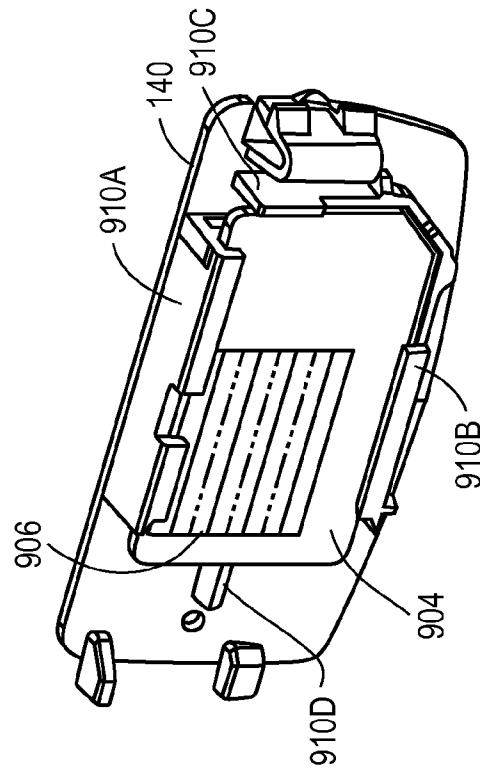

FIG. 9A

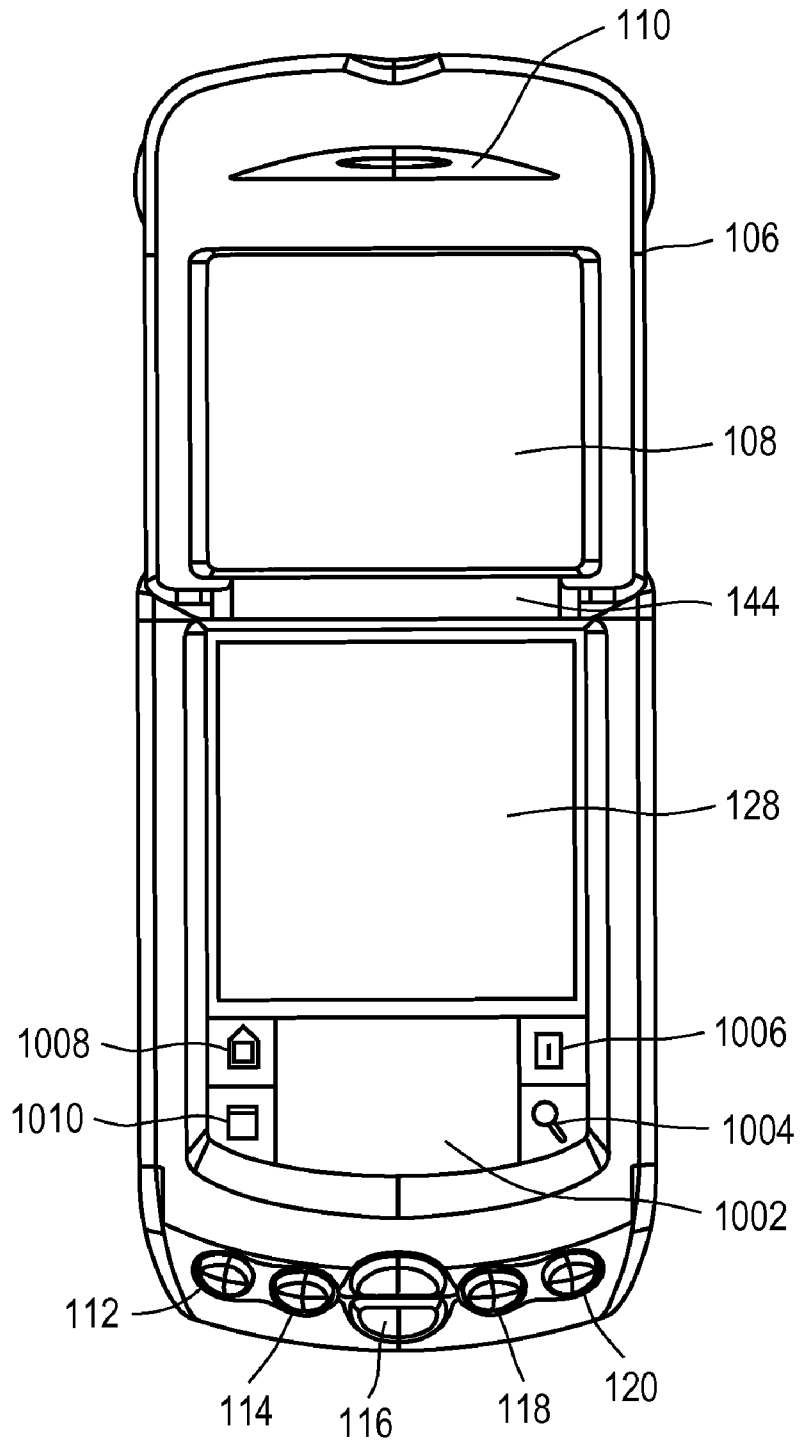

FIG. 10

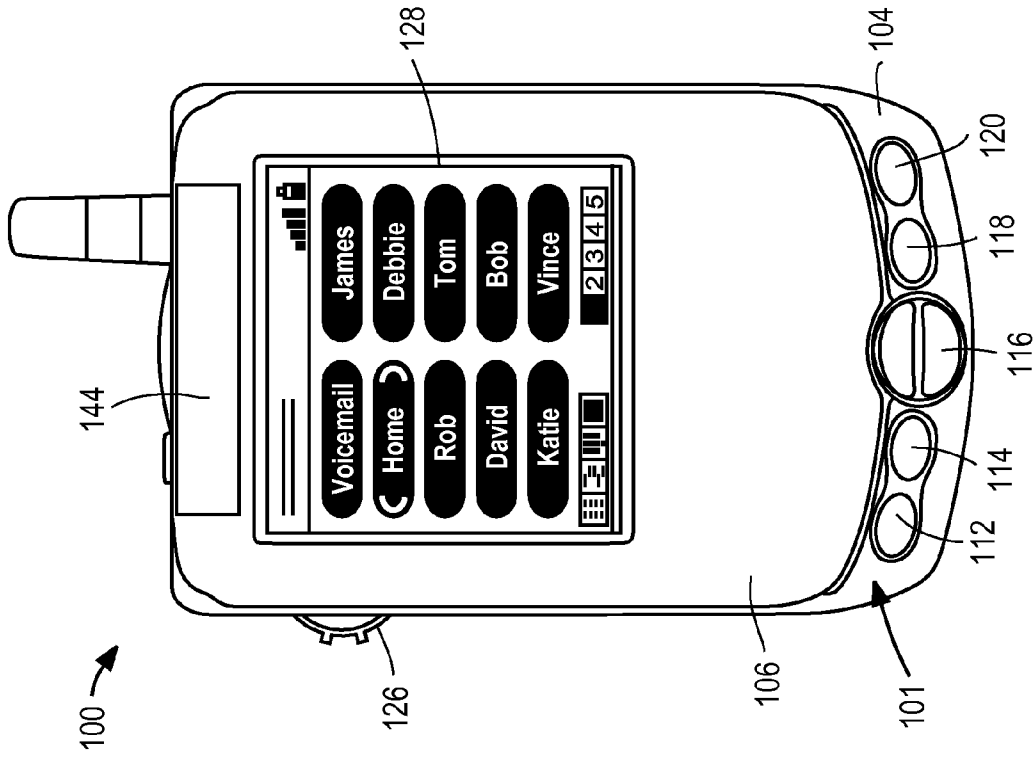

FIG. 11B

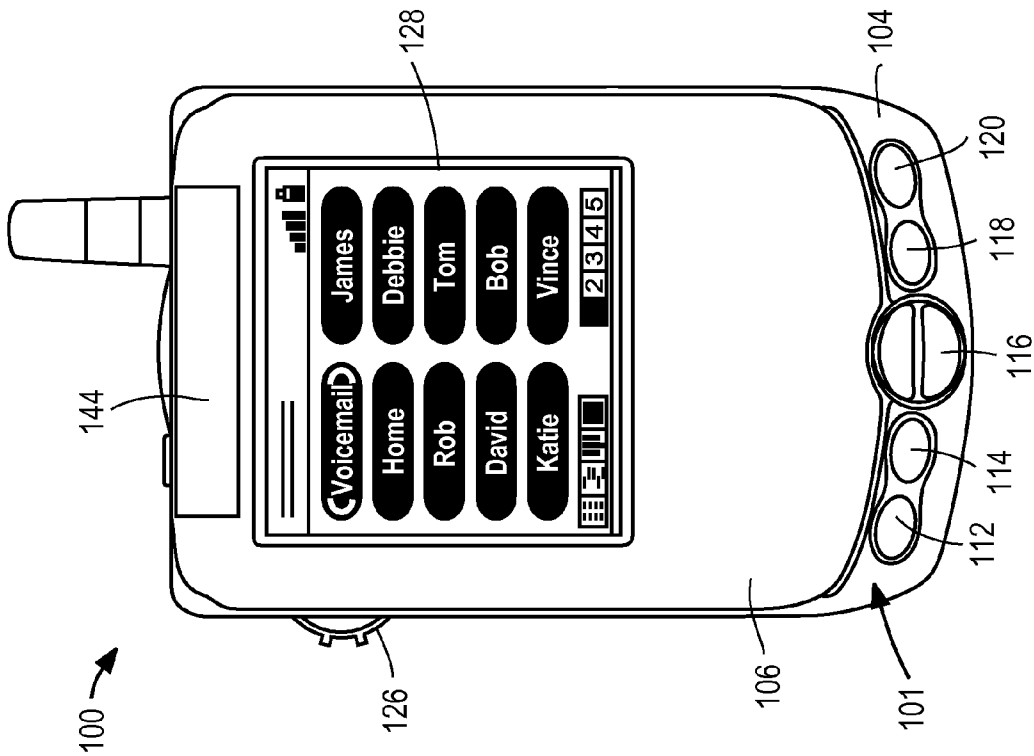

FIG. 11A

1

HAND-HELD DEVICE

CROSS-REFERENCE TO RELATED APPLICATION

This application claims priority under 35 U.S.C. 119(e) from U.S. provisional patent application 60/297,817, having a filing date of Jun. 11, 2001 which is entitled "Handheld Device," inventors Tom Bridgwater, Debbie Chyi, Robert Haitani, Jeff Hawkins, Eric Jacobsen, Will Rees, Peter Skillman, and Karl Townsend and which is hereby incorporated by reference.

BACKGROUND OF THE INVENTION

1. Field of the Invention

The present invention relates generally to systems and methods for a hand-held computing device providing communication services and symbol processing.

2. Description of the Related Art

The integration of services into hand-held devices such as personal digital assistants often involves an increased cost of time to the user to adapt to a new man-machine interface. The man-machine interface aspect of the data entry mechanisms is crucial to decreasing the learning curve time customers need to fully utilize the device for performing its various functions in order to decrease customer frustration. The ease of manipulation of data entry mechanisms enhances the overall device experience.

It is desirable to strike an appropriate balance between burdening the user with a bulkier device on the one hand with dedicated data entry mechanisms as part of the physical interface and on the other hand providing a more limited man-machine interface requiring the user to have to learn more data entry techniques or to consume more time for data entry.

The man-machine interface impacts the acceptability of the device to users because it impacts the extent of services provided, the effective use of the services, and the overall reliability of the device.

SUMMARY OF INVENTION

The present invention provides for various embodiments of a hand-held device for providing communication services, including voice communications, and symbol processing. In one embodiment, the hand-held device comprises a case. The case encloses control logic, for example hardware and/or software, embodying functionality for providing communication services and control logic for performing symbol processing. For example, the case may include a radio functionality for providing communication services. Examples of such communication services are a cellular telephone functionality, text messaging, or wireless Internet access. In the embodiment, a front side comprises a touch-sensitive display and application buttons. In addition, the device comprises a lid comprising a speaker and a transparent portion. In this embodiment, the lid is hinged to the front side. In a closed position, the lid extends over the display, leaving the application physical buttons physically accessible to touch for receiving input wherein the device performs processing responsive to receiving input from the application buttons in the lid closed state.

The lid having a transparent portion advantageously provides convenience to the customer and protection of the device at the same time. For example, a user can see the identity of who is calling on the display without opening the

2

lid while at the same time providing a protective cover of the device's display. The lid itself can also be used to perform functions. For example, closing the lid may turn off the display and place the device in a power saving state. In one embodiment, the power saving state does not affect the processing of the radio module.

In one embodiment, the front side of the device further has a keyboard. An example of a keyboard that may be used is a QWERTY keyboard. The lid in this embodiment extends over the keyboard in the lid closed state. In another aspect of this embodiment, the keyboard may comprise an arrangement of the symbols "0" to "9" in a traditional telephone keypad arrangement. This similar arrangement advantageously allows a user to adjust to using the keypad more readily than if the user had to learn a new arrangement. Similarly, in another aspect, a key associated with the telephone keypad arrangement has a telephone keypad key indicator for distinguishing a telephone keypad key from other types of keys of the keyboard. This advantageously allows a user to find these keys more readily when using the device.

In another embodiment of the invention, instead of a keyboard area, the touch-sensitive display also includes a handwriting area for data entry. Typically, a user will use a screen data entry device such as his finger or a stylus to indicate a symbol for entry or to select an item from a menu.

BRIEF DESCRIPTION OF THE FIGURES

The figures depict one or more embodiments of the present invention for purposes of illustration only. One skilled in the art will readily recognize from the following discussion that alternative embodiments of the structures and methods illustrated herein may be employed without departing from the principles of the invention.

FIG. 1A illustrates a front perspective view of an embodiment of a hand-held computing device with a lid opened in an extended position in accordance with the present invention.

FIG. 1B illustrates a back perspective view of an embodiment of a hand-held computing device with a lid opened in an extended position in accordance with the present invention.

FIG. 1C illustrates a view of the front side of the embodiment of the hand-held device of FIG. 1A in a lid closed state in accordance with the present invention.

FIG. 2 illustrates a block diagram of an embodiment of a system enclosed within the case of the hand-held device comprising control logic for performing functions including functions related to communication services and symbol processing.

FIG. 3A illustrates a legend for understanding the symbols represented by each key of the embodiment of a keyboard layout in FIG. 3B.

FIG. 3B illustrates an embodiment of a QWERTY keyboard layout in which the normal symbol, shifted symbol and option symbol for each key are displayed according to the legend in FIG. 3A.

FIG. 4 illustrates a state diagram of an embodiment of a sequence of key strokes for maneuvering within and between a normal state, a Shift state and the Shift Lock modification states.

FIG. 5 illustrates a state diagram of an embodiment of a sequence of key strokes for maneuvering within and between the normal state, the Option state and the Option Lock modification states.

FIG. 6A illustrates an embodiment of a QWERTY keyboard of the hand-held device in accordance with the present invention.

FIG. 6B illustrates an embodiment of a layout of application buttons on the hand-held device.

FIG. 7 illustrates a matrix table showing examples of actions taken responsive to the state of the lid in accordance with the invention.

FIG. 8A illustrates an embodiment of a stylus for use with the hand-held device.

FIG. 8B illustrates a cross-sectional view of an upper portion of a stylus holder.

FIGS. 8C, 8D, 8E and 8F illustrate different positions of a head of the stylus during the rotation of the stylus into the stylus holder of the device.

FIG. 9A illustrates a block diagram of an embodiment of a door having an identification card holder holding an embodiment of a subscriber identification module (SIM) card.

FIG. 9B illustrates a block diagram view of the device with the door removed to show a card detector unit.

FIG. 10 illustrates an embodiment of the hand-held device comprising a handwriting area upon which a user can enter symbols through the use of a stylus or his or her finger.

FIGS. 11A and 11B illustrate examples of displays shown to a user in response to activation of a user input device on a side of the device.

DETAILED DESCRIPTION

FIG. 1A illustrates a front view of an embodiment of a hand-held computing device with a lid opened in an extended position in accordance with the present invention. The embodiment of a hand-held device **100** depicted in FIG. 1A comprises a case **101** having a front side **104**, and sides, for example, a first side **102**. The front side **104** comprises a display **128**, in this embodiment a liquid crystal display (LCD) that is a touch-sensitive display. A user may use his or her finger or a stylus (See FIG. 8A) for data entry, for example, by indicating selections from a menu. In one embodiment, the display is a color display that displays color images. The front side **104** also comprises a keyboard **103**, e.g. a QWERTY keyboard. Each key (e.g. **124**) of the keyboard is slanted in the same direction or at the same angle as the other keys in this embodiment. Also as shown, a key may have an oval shape.

User input devices embodied as application buttons **112**, **114**, **116**, **118**, **120** are also shown. In this embodiment, one of the application buttons **112** is associated with a telephone application. Another application button **114** is associated with a calendar application. Another application button **116** is associated with a scroll-up, scroll-down feature. Another application button **118** may launch an Internet access application. An application button may be associated with more than one function or more than one an application. For example, one of the application buttons may be associated with an application that provides Internet access and may also double in an option state, for example, for activating another application, examples of which are a memo pad, a to do list, an application providing time in other places or a calculator application. In another example, an application button **120** may be associated with a messaging service, examples of which are electronic mail, e-mail, and Short Message Service (SMS) messaging.

Attached to the front side **104** above the display **128** is a lid **106**. In this embodiment, the lid **106** is a flip lid that is hinged **144** above the display. The lid includes a transparent

portion **108** through which a user can see the display even if the lid is closed. The lid **106** further has a speaker **110** in this embodiment.

As illustrated in this embodiment, the first side **102** includes a user input device, in this embodiment, a jog rocker **126**. Also included on the side **102** of the device is a plug-in socket **130** for a hands-free speaker attachment. Examples of a hands-free speaker attachment may include a full headset or a single earpiece.

FIG. 1B illustrates a back side **142** of the embodiment of the hand-held device of FIG. 1A. Also shown is a top part **146** having an antenna **136**, and a ringer switch **132** which interact with a radio module (See FIG. 2 234) inside of the case that provides for radio communications including cellular telephone functionality. In this embodiment, a power switch **138** is shown on the upper portion of the device. In this embodiment, a two-color light emitting diode (LED) **152** is shown on the upper portion of the device. In this embodiment, an infrared panel port **154** is shown on the upper portion of the device. The top part of the device includes an opening of a stylus holder **134**. The stylus holder **134** (See FIG. 8B) extends cylindrically down the back side of the device. In this illustration of an embodiment of the device, a stylus is seated in the device as illustrated by a head **804** of the stylus. In addition, the back side **142** is shown in this embodiment to comprise a door **140**. The door holds an identification card (see FIG. 9B). One example of such an identification card is a subscriber identification module (SIM) card typically used with portable telephones used within the Global System for Mobile (GSM) communications networks. This feature allows the user to place the card in another device. For example, if a user is on another continent, the user can slip the card into another voice communication device such as a telephone designed to work at the frequencies allocated for that continent, country or group of countries.

FIG. 1C illustrates a view of the front side of the embodiment of the hand-held device of FIG. 1A in which the lid **106** is in a closed position. The lid extends over the keyboard and the display in the closed position. The lid having a transparent portion **108** provides a convenience to the customer and protection to the display of the device at the same time. For example, an alert of an incoming call notification is displayed on the display which is visible through the transparent lid. In this way, the lid also provides a protective cover of the device's display.

The case **101** encloses control logic, for example hardware and/or software, for providing communication services and control logic for symbol processing. Examples of symbols are letters, numbers, punctuation marks, emoticons typically used in e-mail messages and mathematical symbols. An example of communication services is voice communications. FIG. 2 illustrates a block diagram of an embodiment of a system **200** comprising units making up the hardware and/or software for performing these functions. The system may be implemented in a printed circuit board. The system comprises a microprocessor **202**, a read only memory (ROM) **204**, a synchronous dynamic random access memory (SDRAM) **206**, a user interface unit **208** for processing input from the keyboard **103** or a handwriting area (see FIG. 10, **1002**), the jog rocker **126**, the ringer switch **132** and the power switch **138**. Also this unit **208** detects the state of the lid position to determine if the lid is closed or open. Connected to the microprocessor as well is charging circuitry **210** for providing power from the battery **212**. In one embodiment, the microprocessor is a Dragonball VZ MC68VZ328 33 MHz processor. In one embodiment,

the battery is a Li-Ion 600 mAH battery. The charging circuitry is also connected to a cradle connector **226**. The microprocessor is also connected with a liquid crystal display unit **214**, a touch panel unit **216** and a backlight unit **218**. The microprocessor **202** is also connected to a peripheral device transceiver **224**, an example of which is a Universal Serial Bus (USB) transceiver, and an input/output (I/O) port **222**, an example of which is an EIA-232 or a RS-232 port, both of which are also connected to the cradle connector **226**. The microprocessor **202** is also connected to an infrared communication transceiver **220**, an example of which is an Infrared Data Association (IrDA) transceiver. The microprocessor is also connected with speaker unit **228**, an example of which is a piezo speaker, a red/green light emitting diode (LED) **230** unit, and a vibrator unit **232**.

The microprocessor is also connected to a radio module **234** that provides for radio communications including cellular telephone functionality. An example of a radio module that may be used is a Wavcom Wismo GSM Module. Other services provided include Internet access and text messaging. An example of a text messaging service is the Short Message Service (SMS) which provides for sending and receiving short text messages from the hand-held computing device to another communication device, for example a personal digital assistant or a mobile phone.

The radio module is connected to an antenna **236**, an amplifier **238** which is also connected to an internal speaker **240**. The radio module is also connected to an internal microphone **242** as well as a card detector unit **244** and a hands-free attachment connector **246**.

Those of skill in the art will understand that control logic, for example hardware and/or software, enclosed within the device, for example the system depicted in FIG. 2, processes input from user input devices in different forms and performs functions with respect to the input. For example, the user interface unit **208** may be embodied in hardware and/or software under the control of the microprocessor **202**. The microprocessor **202** may execute software instructions for receiving input and responding to it appropriately from software **205** stored in a memory such as the read only memory **204**, or random access memory such as the shown SDRAM **206** and/or in the user interface unit **208**.

A keyboard, such as a QWERTY keyboard, is advantageous for e-mail and other forms of electronic messaging in a hand-held device.

As shown in the legend of FIG. 3A, associated with each key of the keyboard are three symbols, a normal symbol, a shifted symbol, and an option symbol.

In one version of the invention, a version of a QWERTY keyboard is used. For example, FIG. 3B illustrates an example of a complete keyboard layout. The keyboard comprises the following keys: the letters a-z (26 keys), punctuation marks such as a period “.” key, the “. . .” symbol key, and keys for such functions as “Space”, “Return”, “Backspace”, as well as a “Shift” key, an “Option” key, and a “Menu/Command” key. As shown, in the option state, the “Shift” key performs a “Find” function, and the “Menu/Command” key provides a “Launcher” key for launching a display for accessing applications. It will be noted that beginning in the top row at the left side, the first six letters from left to right are “qwerty”.

In the embodiment of FIG. 3B, the normal symbol, shifted symbol and option symbol represented by each key is displayed according to the legend in FIG. 3A. The keyboard lets a user enter different symbols represented by a single key via the use of modification states, for example Shift and

Option, as illustrated in FIG. 3A. Other keys function the same in more than one modification state.

An example of a QWERTY keyboard using the states of the keyboard layout of FIG. 3B is shown in FIG. 6A. In the normal, unmodified state, the keys produce the main character printed on them. For example, pressing key **602** in FIG. 6A will cause a “q” to be produced in the unmodified state, and key **604** in FIG. 6A will cause a “p” to be produced according to the keyboard layout illustrated in FIG. 3B.

In this example embodiment, the “Shift” key is a modifier key. In this example layout, the “Option” key is also a modifier key.

There are two ways to use the modifier keys (Shift and Option) to enter a shift- or option-modified character. One way known as serial modification means pressing and releasing the modifier key and then pressing the key to be modified. In other words, the keys are typed one after the other. Another way is known as parallel modification and involves pressing and holding a modifier key. In one embodiment of the invention both forms of modification are used. In another embodiment, only serial modification would be used. In a different embodiment, only parallel modification would be used.

The shift modification state is discussed next. There are two “Shift” states to consider, both the “Shift” and “Shift Lock” states. In the Shift state, the keys produce a capital version of the main character printed on them.

FIG. 4 illustrates a state diagram of an embodiment of a sequence of key strokes for maneuvering within and between the normal state **402**, the Shift state **406** and the Shift Lock **410** modification states. For example, receiving input indicating that the **404** Shift key has been pressed once puts the device in Shift state **406**. The Shift state **406** is canceled upon the entry **414** of the Shifted-modified character. Also, pressing backspace **414** clears the Shift Lock state and places the state back to Normal State. However, by pressing backspace, the previous character may also be deleted. Pressing Shift **408** in the Shift state puts the device in Shift Lock state **410**. Shift Lock state **410** is not canceled upon the entry of the Shifted-modified character.

Pressing Shift **412** in Shift Lock state clears the state.

Another example of a modification is the “Option” state. In the Option state, a key produces another symbol. For example, in FIG. 3B according to the legend of FIG. 3A, in the Option state, if the user presses the “m” key, a “9” is produced.

FIG. 5 illustrates a state diagram of an embodiment of a sequence of key strokes for maneuvering within and between the normal state **502**, the Option state **506** and the Option Lock **510** modification states. For example, pressing **504** the Option key once puts the device in Option state **506**. The Option state **506** is canceled upon the entry **514** of the Option-modified character. Also, pressing backspace **514** clears the Option Lock state and places the state back to Normal state. However, by pressing backspace, the previous character may also be deleted. Pressing Option **508** in the Option state puts the device in Option Lock state **510**. Option Lock state **510** is not canceled upon the entry of the Option-modified character.

Pressing Option **512** in the Option Lock state clears the state.

Typically, there is a repeat rate associated with action of a key or combination being held down. In one embodiment, all text entry has the same repeat rate. For instance, holding down the “j” key will produce j’s at the same rate as holding down shift+j produces J’s and option+j produces 5’s.

The lid in the closed position prevents unintended entry from the keyboard when the lid is pressed down against the keyboard because input from the keyboard is disabled when the lid is in the closed position. For example, the user interface unit **208** shown in FIG. **2** receives input from the keyboard. Under the programmed control of the microprocessor **202**, the lid-closed state is recognized and the input is not processed. Additionally there are other power-saving aspects of the device in a lid-closed position. In one example of a power-saving aspect of the device, responsive to the device being in a lid-closed state and the device being in a device-power-on state, the device disables a repeat functionality associated with the user input device. A typical scenario is that something in a briefcase or purse is pressing against the power button. An application button **112**, **114**, **118**, **120** or the scroll button **116** is also being pressed by something. By disabling the repeat functionality, the drain on the battery is reduced. In another example of a power-saving aspect of the device in a lid-closed state and a device-power-on state, a timeout setting for receiving indication of further activation of the device is shorter than in the lid-open state thereby also reducing the drain on the battery.

In one aspect of the invention, a keyboard provides for an arrangement of the digits "0" to "9" similar to their arrangement on a touch-tone telephone keypad. This similar arrangement advantageously allows a user to adjust to using the keypad more readily than if the user had to learn a new arrangement.

FIG. **6A** illustrates an embodiment of a keyboard **103** and a subset of keys **610**, **612**, **614**, **616**, **618**, **620**, **622**, **624**, **626**, **630** whose option symbols, as shown in FIG. **3B**, together comprise a keypad of the digits zero (0) through nine (9) as they would appear on a typical touch-tone telephone keypad. For example, normal character keys "y", "u" and "i" have respectively as their option symbols "1", "2" and "3". This embodiment includes an option key **628**. The keypad is an advantageous aspect of the invention providing ease of dialing a telephone number because the user is typically already familiar with a touch-tone keypad arrangement. FIG. **6A** also illustrates another embodiment of the telephone keypad comprising the digits "0" to "9" as option symbols as discussed above as well as the symbols "*" and "#". As shown, the "*" symbol is an option symbol for the key **642** labeled "T" that is next to the key **610** having "1" as an option symbol. Additionally, the "#" symbol is an option symbol for the key **644** labeled with the letter "O" that is next to the key **614** having "3" as an option symbol. In one example, receiving input indicating that the option lock state has been entered, the functionality of dialing a number as on a telephone keypad in either embodiment is provided to a user.

Similarly, in another aspect, the keys associated with the telephone keypad arrangement have a telephone keypad key indicator for distinguishing a telephone keypad key from other keys on the keyboard. This advantageously allows a user to find these keys more readily when using the device. In one embodiment shown in FIG. **6A**, the distinguishing indicator is a visual indicator shown as that portion **606**, which may be all or less than all, of the area of one or more of the keys associated with the digits "0" to "9" comprising a color different than the keys not associated with the digits "0" to "9". Other examples of indicators providing sensations such as visual, touch or audio sensations to indicate the telephone keys include, but are not limited to, a different tactility, a different surface, for example a surface including a raised knob on a telephone keypad key, a different key shape, a different material, a different back lighting scheme,

a different degree of transparency or translucency, an audible signal upon key depression, or a different pattern.

FIG. **6B** illustrates an embodiment of the layout of the application buttons of the hand-held device. In this embodiment, one of the application buttons **632** is associated with a telephone application. Another application button **634** is associated with a calendar application. Another application button **636** is associated with a scroll-up, scroll-down feature. For example, a user may use this feature to scroll through entries in a menu. In this embodiment, application button **638** is associated with an application that provides Internet access. In this embodiment, an application button **640** is associated with a messaging application.

As shown in the embodiment of FIG. **1A**, the device further comprises a user input device **126** located on a side **102** of the device, the input of the user input device being processed when the lid is in the closed position as well as in the open position. In this embodiment, the user input device is a jog rocker **126**. The jog rocker reacts to four input actions: up, down, press in, and press in and hold. The jog rocker provides for convenient one-handed use to perform a function when the device is in a lid-closed state. Although within the variety of applications offered by the hand-held device, the jog rocker's inputs will have application specific results, the jog rocker may be used to turn on the device and launch a user selectable predetermined application, for example, the telephone application, by a press of the jog rocker or a press and hold of the jog rocker. In this embodiment, the jog rocker's behavior is executed on a jog rocker press rather than release.

FIGS. **1A** and **1B** illustrate examples of displays shown to a user in response to movements of the jog rocker in a lid-closed state. In one example, if the person wishes to make a telephone call, and the device is in a lid-closed state and a device power-save state, the person may press the jog rocker with one hand. The device receives input indicating activation of the jog rocker. Responsive to the activation of the jog rocker, the device is transitioned from a device power-save state to a device power-on state. In one embodiment, the device power-on state is a state in which the device is fully operational for performing activities including displaying views on the display. The device launches an application and displays a view of the application on the display. A default or a user-selectable view is displayed.

FIG. **11A** illustrates a telephone application as the user selectable application. In another example, with the device is in a lid-closed state and a device power-save state, the user presses the telephone application button **112** to activate the telephone application. The device receives input indicating activation of the application button. Responsive to the press of the application button, the device is transitioned from a device power-save state to a device power-on state. The device launches an application associated with the button and displays a view of the application associated with the button on the display.

FIG. **11A** illustrates a view of a speed dial menu with an initial highlight on a "Voicemail" screen button. The initial view of an application may also be user selectable. With the lid closed, the speed dial menu shows through the transparent portion **108** of the closed lid **106** on the display **128**. Responsive to receiving input indicating activation of the up/down application scroll button or activation of the jog rocker up or down, the view is updated responsive to performing the function of scrolling down as is illustrated by the highlighting of the next item in the list.

FIG. **11B** illustrates the highlighting of a screen menu button "Home" associated with a telephone number.

Responsive to receiving input indicating a press of the jog rocker, the “Home” number will be dialed. In this way, with a limited number of activations of the jog rocker on the side of the device or of the jog rocker and an application button, which activations may be performed by one hand, the display is protected by the closed lid, and the user can proceed with the call using a hands-free attachment such as a headset.

The behavior of the lid can also activate the performance of functions with respect to the device itself and within an application. Those of skill in the art will understand that control logic, for example hardware and/or software, enclosed within the device, for example the system depicted in FIG. 2, processes input indicating the lid states and/or transitions between lid-states and performs functions with respect to this input. For example, the user interface unit 208 comprising a lid position detector may be embodied in hardware and/or software under the control of the microprocessor 202. In one embodiment, the lid position detector comprises a magnet in the lid and a magnetic field sensor, for example a hall effect sensor, in the front side of the case, for example near the keyboard. The microprocessor 202 may execute software instructions for receiving input indicating the lid states and/or transitions between lid-states and responding to it appropriately from software programs stored in a memory such as read only memory 204, the SDRAM 206, and/or in the user interface unit 208.

FIG. 7 illustrates a matrix table showing examples of actions taken responsive to a transition from one lid-state to another. In one example of lid behavior, responsive to being in a device power-save state and detecting a transition from a lid-closed state to a lid-open state, transitioning the device from the device power-save state to the device power-on state and launching an application.

An application assigned to the lid either by default or by user-selection such as the telephone application may also be launched. In the device power-off state, closing the lid does not effect a change in the device’s functioning or power state.

FIG. 7 also describes examples of the results of lid behavior in the device power on state if the device is running the telephone application. In the examples of FIG. 7, a notification time period of one second is used. Responsive to the device being in a power-on-state and a lid-closed state, no action is taken with respect to an incoming call in this embodiment within one second of the incoming call notification. However, after one second of notification, responsive to detecting a transition from the lid-closed state to the lid-open state, the device processes the call including answering the call. The use of opening the lid to answer the call saves the user time in by not having to necessarily find and select additional buttons.

In another example, the device is in a power-on-state and a lid-open state. Responsive to being within one second of the incoming call notification and detecting a transition from a lid-open state to a lid-closed state (e.g. closing the lid), no action is taken with respect to the incoming call in this embodiment.

In another example, the device is in a device power-on state and a lid-open state. The device processes an incoming call notification. An alert to the user may be sent indicating that a call has been received. Responsive to detecting a transition from a lid-open state to a lid-closed state after a notification time period of the incoming call, the call is ignored and the device is transitioned from the device power-on state to the device power-save state. A ring indicating the call may be silenced or a vibration ceased.

During an active call, FIG. 7 illustrates actions taken responsive to the state of the lid when a hands-free attachment, in this example a headset, is being used and when it is not being used. In the embodiment of FIG. 1A, if a user is not using a hands-free attachment such as a headset, the lid will be open so that the user can hear the caller through the speaker 110 in the lid 106. If the user is using a hands-free attachment, opening the lid will not effect the call.

In one example, the device is in a device power-on state and a lid-open state. The device is processing an active call during a no-hands-free attachment state. A no headset state is an example of a no-hands-free attachment state. Responsive to detecting a transition from a lid-open state to a lid-closed state, the active call is ended. An audio, visual or audiovisual confirmation of the hang-up may be generated. For example, the confirmation may be displayed on the display for a period, for example 2 seconds. The device transitions from a device power-on state to a device power-save state. The device allows the user to end the call by closing the lid.

However, if a hands-free attachment is in use such as by a driver, the user may not want to hang-up the call but also does not want to leave the device lid open in a purse or on a seat where it may get scratched or from which it may fall. In this example, the device is in a device power-on state and a lid-open state and is processing an active call during a hands-free attachment state. Responsive to detecting a transition from a lid-open state to a lid-closed state, the device transitions from a device power-on state to a device power-save state. However the active call is maintained by the device until receiving direction to end the call. An example of direction would be input requesting that the call be ended. Such direction may be indicated by detection that a button on a hands-free attachment has been pressed to end the call.

In another example, the device may be in a device power-on state and a lid-closed state. For example, the device received input indicating a depression of the power button 138 while the lid is closed or input indicating activation of a user input device such as one of the application buttons. In this combination of states, the opening of the lid in this example does not cause the device switch from a currently running application to one assigned to the action of opening the lid. This is helpful to a user so that the user does not lose her place in the current application by opening the lid.

FIG. 8A illustrates an embodiment of a stylus 801 for use with the hand-held device. The stylus has a body portion 802 of an elongated cylindrical shape with a tapered rounded tip 809 and a head portion 804. The head portion 804 has a cam, in this embodiment a lower lip 806 that slopes downward at a first angle.

FIG. 8B illustrates a cross-sectional view of the upper portion of the stylus holder 134. The holder 134 comprises a rim 810 that slopes downward at a second angle which may be equal to the first angle or may be a different angle. The combination of the two angles cause the lip 806 of the stylus head to slide along the rim in a cam movement so as to transform the rotary motion of the stylus into a linear motion downward into the holder. The combination provides for a self-alignment of the stylus with the holder. The interior of the holder comprises a protrusion or an insertion 808 such as a piece of foam rubber, against which the rounded tip 809 of the stylus slides so as to glide the elongated body portion 802 into the holder.

FIGS. 8C, 8D, 8E and 8F illustrate the rotation of the stylus 801 into the holder of the device. In FIG. 8C, the lip

11

806 contacts the rim 810 of the opening. In FIG. 8D, responsive to linear downward pressure on the stylus, the lip 806 rotates along the upper part of the rim 810 causing the stylus to move further downward into the holder. In FIG. 8E, being guided by the combination of the downward slope of the lip at a first angle and the downward slope of the rim at a second angle, the head further rotates causing the stylus to move further downward. Finally, in FIG. 8F, the lip of the stylus is aligned with the rim of the holder so that the stylus comes to be fully seated in the holder. The use of the lip and rim of the holder 134 allows the stylus to come to full seat in the holder responsive to the linear motion of being pressed down.

FIG. 9A illustrates an embodiment of the door 140 having a card holder for an identification card. The card holder in this embodiment comprises the structures 910A, 910B, 910C and 910D. An example of a card that may be held in place is the subscriber identification module (SIM) card that is commonly used with the GSM communication networks as described above. FIG. 9A illustrates an embodiment of a SIM card 904 having electrical contacts 906. FIG. 9B illustrates a block diagram view of the device with the door 140 removed to show a card detector unit 244 having a communication coupling 912 to the radio module 234 through a printed circuit board 908 internal to the device. The printed circuit board may embody a system such as the system embodiment shown in FIG. 2. The card detector unit 244 detects the presence of the card. For example, the card detector unit may comprise one or more electrical contacts 914 positioned to contact with one or more electrical contacts 906 on the SIM card. Through the communication coupling 912 with the card detector unit, the radio module 234 will note the lack of the card's presence and the hardware and software will function to alert the user. For example, an alert may be displayed to the user. In another embodiment, the card detector unit comprises a switch for detecting the presence of the card. The switch would also be coupled 912 to the radio module.

FIG. 10 illustrates another version of the embodiment of the hand-held device of FIGS. 1A, 1B and 1C. In the version of FIG. 10, the device comprises a handwriting area 1002 upon which a user can enter symbols through the use of a stylus or his or her finger. The icons surrounding the handwriting area are those typically used with the Graffiti™ program typically implemented in PALM OS® devices. The icons when tapped perform a function associated with the icon. For example, an applications icon 1008 opens applications when tapped. The other icons are the menu icon 1010, the calculator icon 1006, and the find function icon 1004 which allows a user to find text anywhere in his data. In the closed position, the embodiment of FIG. 10 would appear as the embodiment of the device having a transparent lid 108 in the closed position as illustrated in FIG. 1C. This embodiment of a hand-held device also comprises a system such as the example illustrated in FIG. 2 comprising hardware and software for providing communication services and symbol processing. For example, this device also includes radio communications functionality, for example, cellular telephone functionality as discussed above.

The above description is included to illustrate the operation of one or more embodiments and is not meant to limit the scope of the invention. The scope of the invention is to be limited only by the following claims. From the above discussion, many variations will be apparent to those skilled in the art that would yet be encompassed by the spirit and scope of the invention.

12

What is claimed is:

1. A hand-held computing device structured to include a telephone component comprising:

a case having a front face, the case having within a plane a long axis and a short axis;
a display screen located on the front face;
a speaker located along a top portion of the front face above the display screen;
a microphone below the display screen; and

a non-foldable keyboard located on the front face below the display screen comprising three rows of keys oriented perpendicular to the long axis of the case, at least nine keys comprising a primary symbol and a secondary symbol, the primary symbols for successive keys in the first row of keys representing the letters "Q", "W", "E", "R", "T", and "Y",

the at least nine keys having secondary symbols "1" to "9" comprising a touch-tone telephone keypad arrangement of keys, the secondary symbols "1", "2", and "3" in the first of the three rows of keys, the secondary symbols "4", "5", and "6" in a second of the three rows of keys, and the secondary symbols "7", "8", and "9" in a third of the three rows of keys, each secondary symbol associated with a key including a primary symbol, and comprising an option key configured to set the non-foldable keyboard in one of a plurality of states, a first state corresponding to a single use of a secondary symbol in the touch-tone telephone keypad arrangement, a second state corresponding to consecutive use of any secondary symbols in the touch-tone telephone keypad arrangement, and a third state corresponding to use of only primary symbols in the touch-tone telephone keypad arrangement,

wherein the keys in the touch-tone telephone keypad arrangement have a common visual characteristic, at least one key not in the telephone keypad arrangement lacks the common visual characteristic of the keys in the telephone keypad arrangement, and wherein in response to execution of the telephone component, the non-foldable keyboard is set to the second state for use of the secondary symbols of the keys in the telephone keypad arrangement.

2. The device of claim 1 wherein a key having a secondary symbol of "0" is in a fourth row of keys.

3. The device of claim 1 wherein a row of the keyboard includes a key representing at least one of the "*" symbol and the "#" next to a key of the telephone keypad arrangement.

4. The device of claim 1 wherein each primary symbol is a separate key.

5. The device of claim 1 wherein the option key is in one of the three rows of keys.

6. In a handheld device comprising a data entry component and a wireless telephone component, the device having a long axis and a short axis within a plane, a non-foldable keyboard comprising:

a plurality of keys arranged in a configuration having key rows oriented perpendicularly with respect to the long axis of the device, one of the key rows comprising successive keys representing the letters Q, W, E, R, T, and Y,

wherein the plurality of keys comprises at least nine multi-value keys, each multi-value key associated with at least a primary value and a numeric secondary value, the at least nine multi-value keys having a common visual characteristic and being arranged to form part of the configuration, the at least nine multi-value keys

13

further being arranged in a telephone keypad arrangement, the keys in the configuration comprising at least one key not having the common visual characteristic of the nine multi-value keys, the non-foldable keyboard located below a display screen along the long axis of the handheld device,

wherein the plurality of keys further comprises an option key configured to set the plurality of keys in one of a plurality of states, a first state corresponding to a single use of a numeric secondary value of a multi-value key, a second state corresponding to consecutive use of any numeric secondary value of the multi-value keys, and a third state corresponding to use of only the primary value of a multi-value key, and

wherein in response to activation of the wireless telephone component, the least nine multi-value keys initially set to the second set and operable as touch-tone keys.

7. The keyboard of claim 6, wherein the at least nine multi-value keys are arranged in at least three rows, each row comprising at least three multi-value keys.

8. The keyboard of claim 7, wherein the at least three rows comprise:

a first row comprising multi-value keys associated with numeric values of 1, 2, and 3;

a second row comprising multi-value keys associated with numeric values of 4, 5, and 6; and

a third row comprising multi-value keys associated with numeric values of 7, 8, and 9.

9. The keyboard of claim 8, further comprising a tenth multi-value key associated with at least a primary value and a numeric secondary value of 0, wherein the tenth multi-value key is arranged in a fourth row.

10. The keyboard of claim 7, wherein the at least three rows comprise:

a first row comprising multi-value keys associated with at least three primary values selected from the group consisting of Q, W, E, R, T, Y, U, I, O, and P, and further associated with numeric values of 1, 2, and 3;

a second row comprising multi-value keys associated with at least three primary values selected from the group consisting of A, S, D, F, G, H, J, K, L, and “;”, and further associated with numeric values of 4, 5, and 6; and

a third row comprising alphabetic/numeric multi-value keys associated with at least three primary values selected from the group consisting of Z, X, C, V, B, N, M, “;”, and “.”, and further associated with numeric values of 7, 8, and 9.

11. The keyboard of claim 7, wherein the at least three rows comprise:

a top row comprising multi-value keys associated with numeric values of 1, 2, and 3;

a middle row comprising multi-value keys associated with numeric values of 4, 5, and 6; and

a bottom row comprising multi-value keys associated with numeric values of 7, 8, and 9.

12. The keyboard of claim 7, wherein the plurality of keys further comprises at least one additional multi-value key associated with at least a primary value and a secondary value, the additional multi-value key being arranged to form part of the configuration, the at least one additional multi-value key further being arranged in a fourth row, so that the at least nine multi-value keys and the at least one additional multi-value keys collectively emulate a telephone keypad arrangement.

14

13. The keyboard of claim 12, wherein the at least one additional multi-value key is associated with a numeric value of 0.

14. The keyboard of claim 7, wherein the plurality of keys further comprises at least three additional multi-value keys, each associated with at least a primary value and a secondary value, the at least three additional multi-value keys being arranged to form part of the configuration, the at least three additional multi-value keys further being arranged in a fourth row, so that the at least nine multi-value keys and the at least three additional multi-value keys collectively emulate a telephone keypad arrangement.

15. The keyboard of claim 14, wherein the at least three rows comprise:

a first row comprising multi-value keys associated with numeric values of 1, 2, and 3;

a second row comprising multi-value keys associated with numeric values of 4, 5, and 6; and

a third row comprising multi-value keys associated with numeric values of 7, 8, and 9; and

wherein the fourth row comprises multi-value keys associated with secondary values of *, 0 and #.

16. The keyboard of claim 14, wherein the at least three rows comprise:

a top row comprising multi-value keys associated with numeric values of 1, 2, and 3;

a second row, below the top row, comprising multi-value keys associated with numeric values of 4, 5, and 6; and

a third row, below the second row, comprising multi-value keys associated with numeric values of 7, 8, and 9;

and wherein the fourth row, located below the third row, comprises multi-value keys associated with secondary values of *, 0 and #.

17. The keyboard of claim 6, wherein the at least nine multi-value keys comprise:

at least one selected from the group consisting of:

a key associated with a primary value of Y and a numeric value of 1,

a key associated with a primary value of U and a numeric value of 2, and

a key associated with a primary value of I and a numeric value of 3;

at least one selected from the group consisting of:

a key associated with a primary value of H and a numeric value of 4,

a key associated with a primary value of J and a numeric value of 5, and

a key associated with a primary value of K and a numeric value of 6; and

at least one selected from the group consisting of:

a key associated with a primary value of B and a numeric value of 7,

a key associated with a primary value of N and a numeric value of 8, and

a key associated with a primary value of M and a numeric value of 9.

18. The keyboard of claim 17, further comprising a multi-value key associated with at least a numeric value of 0.

19. In a handheld device structured to include data entry operation and a wireless telephone operation, the device having within a plane a long axis and a short axis, a non-foldable keyboard comprising:

a plurality of keys arranged in a configuration having key rows oriented perpendicularly with respect to the long

15

axis of the device, one of the key rows comprising successive keys representing the letters Q, W, E, R, T, and Y;

wherein the plurality of keys comprises at least nine multi-value keys, each multi-value key associated with at least a primary value and a numeric secondary value, the at least nine multi-value keys having a common visual characteristic, the at least nine multi-value keys having the common visual characteristic arranged in at least three successive rows and three successive columns, the non-foldable keyboard located below a display screen along the long axis of the handheld device, wherein the plurality of keys further comprises an option key configured to set the at least nine-multi-value keys in one of a plurality of states, a first state corresponding to a single use of a numeric secondary value of the multi-value keys, a second state corresponding to consecutive use of any numeric secondary values of the multi-value keys, and a third state corresponding to use of only primary keys of the multi-value keys, and

wherein in response to operation of the wireless telephone the at least nine multi-value keys are initially set to the second state and operable as a touch-tone keys.

20. The keyboard of claim 19, wherein the plurality of keys further comprises at least one additional multi-value key, associated with at least a primary value and a secondary value, the at least one multi-value key being arranged in a fourth row.

21. The keyboard of claim 20, wherein the secondary value of the additional multi-value key is 0.

22. The keyboard of claim 19, wherein the plurality of keys further comprises at least three additional multi-value keys, each associated with at least a primary value and a secondary value, the at least three multi-value keys being arranged in a fourth row.

23. The keyboard of claim 22, wherein the secondary values of the at least three additional multi-value keys are *, 0, and #.

24. The keyboard of claim 19, wherein each primary value comprises an alphabetic value.

25. The keyboard of claim 19, wherein the plurality of keys arranged in the configuration further comprises at least one multi-value key associated with at least a primary value and a non-alphabetic non-numeric secondary value.

26. The keyboard of claim 25, wherein the multi-value keys associated with numeric secondary values are visually distinguishable from the at least one multi-value key associated with a non-alphabetic non-numeric secondary value.

27. The keyboard of claim 25, wherein at least a portion of each multi-value key associated with a numeric secondary value is a first color, and at least a portion of each multi-value key associated with a non-alphabetic non-numeric secondary value is a second color different from the first color.

28. The keyboard of claim 25, further comprising:
for at least one multi-value key associated with a numeric secondary value, a label identifying the secondary value, the label having a first color; and
for at least one multi-value key associated with a non-alphabetic non-numeric secondary value, a label identifying the secondary value, the label having a second color different from the first color.

29. The keyboard of claim 25, wherein at least one non-alphabetic non-numeric secondary value comprises a punctuation mark.

16

30. The keyboard of claim 19, wherein the device further comprises a processor, for interpreting user activation of a multi-value key as one of the values of an activated multi-value key.

31. The keyboard of claim 19, wherein the device interprets user activation of a multi-value key as one of the values of an activated multi-value key.

32. The keyboard of claim 19, wherein the keyboard is adapted to detect key presses by a user; and

wherein, responsive to the keyboard detecting a key press of a multi-value key, the device interprets the key press as one of the values of the pressed key.

33. The keyboard of claim 32, further comprising: a modifier key, for specifying which value of a multi-value key is intended.

34. The keyboard of claim 33, wherein, responsive to the keyboard detecting a key press of the modifier key, the device interprets a subsequent key press of a multi-value key as the secondary value of the pressed multi-value key.

35. The keyboard of claim 33, wherein, responsive to the keyboard detecting the modifier key being held in a pressed position while a multi-value key is pressed, the device interprets the key press of the multi-value key as the secondary value of the pressed multi-value key.

36. The keyboard of claim 33, wherein: the keyboard has at least two modes, including a first mode in which the device interprets a key press as the primary value of the pressed key, and a second mode in which the device interprets a key press as the secondary value of the pressed key, and

wherein, responsive to the keyboard detecting a key press of the modifier key, the keyboard switches from one of the modes to another of the modes.

37. The keyboard of claim 19, wherein: the keyboard has at least two modes, including a first mode in which the device interprets a key press as the primary value of the pressed key, and a second mode in which the device interprets a key press as the secondary value of the pressed key.

38. The keyboard of claim 19, further comprising: a modifier key, for specifying which value of a multi-value key is intended.

39. The keyboard of claim 19, wherein each key in the plurality of keys arranged in the configuration is associated with an alphabetic value and a secondary value.

40. The keyboard of claim 19, wherein the handheld device comprises an e-mail device.

41. The keyboard of claim 19, wherein the handheld device comprises an e-mail device adapted to operate in conjunction with a wireless network.

42. The keyboard of claim 19, wherein: for each of at least a subset of the multi-value keys, the keyboard further comprises a label identifying at least the primary value and the numeric secondary value of the multi-value key.

43. The keyboard of claim 42, wherein each label is printed on the corresponding key.

44. The keyboard of claim 42, wherein each label is printed adjacent to the corresponding key.

45. The keyboard of claim 19, wherein the handheld device further comprises a telephone dialing component, for, responsive to user activation of a sequence of keys having numeric secondary values, dialing a telephone number specified by the key sequence.

46. The keyboard of claim 19, wherein each key in the plurality of keys is tilted at a substantially common angle.

47. The keyboard of claim 19, wherein each key in the plurality of keys is oval shaped.

48. The keyboard of claim 19, wherein the handheld device further serves as an e-mail device.

49. The keyboard of claim 19, wherein the plurality of keys further comprises at least one additional multi-value key, associated with a primary value and a secondary value, the at least one additional multi-value key being arranged in a fourth row.

50. The keyboard of claim 19, wherein the plurality of keys further comprises at least three additional multi-value keys, each associated with a primary value and a secondary value, the at least three additional multi-value keys being arranged in a fourth row.

51. In a handheld device structured to include a data entry operation and a wireless telephone operation, the device having within a plane a long axis and a short axis, a non-foldable keyboard comprising:

a plurality of keys arranged in a configuration having key rows oriented perpendicularly with respect to the long axis of the device, one of the key rows comprising successive keys representing the letters Q, W, E, R, T, and Y;

wherein the plurality of keys comprises at least ten multi-value keys, each associated with at least a primary value and a secondary value, the at least ten multi-value keys having a common visual characteristic and being arranged in at least four rows, wherein at least three of the rows each comprise at least three multi-value keys, the keys in the configuration comprising at least one key not having the common visual characteristic of the ten multi-value keys, the non-foldable keyboard located below a display screen along the long axis of the handheld device,

wherein the plurality of keys further comprises an option key configured to set the at least ten multi-value keys in one of a plurality of states, a first state corresponding to a single use of a secondary value of a multi-value key, a second state corresponding to consecutive use of any secondary value of the multi-value keys, and a third state corresponding to use of only the primary values of a multi-value key, and

wherein in response to operation of the wireless telephone the at least nine multi-value keys initially set to the second state and operable as a touch-tone keys.

52. The keyboard of claim 51, wherein the plurality of keys arranged in the configuration further comprises at least one multi-value key associated with at least a primary value and a non-alphabetic non-numeric secondary value.

53. The keyboard of claim 52, wherein the at least ten multi-value keys are visually distinguishable from the at least one multi-value key associated with a non-alphabetic non-numeric secondary value.

54. The device of claim 1, further comprising:

a display screen located on the front face of the case, positioned above the keyboard, wherein both the key-

board and the display screen are horizontally centered about the long axis of the case.

55. The device of claim 54, wherein the keys in a telephone keypad arrangement form a block that is not horizontally centered about the long axis of the case.

56. The device of claim 1, further comprising: a plurality of navigation controls on the front face of the case and positioned symmetrically about the long axis of the case.

57. The device of claim 1, wherein the keyboard is usable without unfolding the device.

58. The device of claim 1, wherein the device is adapted to function as a wireless telephone.

59. The keyboard of claim 6, wherein the keyboard is horizontally centered about the long axis of the case and is positioned below a display screen located on the front face of the case and also centered about the long axis of the case.

60. The keyboard of claim 59, wherein the at least nine multi-value keys form a block that is not horizontally centered about the long axis of the case.

61. The keyboard of claim 6, wherein the keyboard is positioned on a front face of the device that also includes a plurality of navigation controls positioned symmetrically about the long axis of the case.

62. The keyboard of claim 6, wherein the keyboard is usable without unfolding the device.

63. The keyboard of claim 19, wherein the keyboard is horizontally centered about the long axis of the device and is positioned below a display screen located on the front face of the device and also centered about the long axis of the device.

64. The keyboard of claim 63, wherein the at least nine multi-value keys form a block that is not horizontally centered about the long axis of the device.

65. The keyboard of claim 19, wherein the keyboard is positioned on a front face of the device that also includes a plurality of navigation controls positioned symmetrically about the long axis of the device.

66. The keyboard of claim 19, wherein the keyboard is usable without unfolding the device.

67. The keyboard of claim 51, wherein the keyboard is horizontally centered about the long axis of the device and is positioned below a display screen located on the front face of the device and also centered about the long axis of the device.

68. The keyboard of claim 67, wherein the at least ten multi-value keys form a block that is not horizontally centered about the long axis of the device.

69. The keyboard of claim 51, wherein the keyboard is positioned on a front face of the device that also includes a plurality of navigation controls positioned symmetrically about the long axis of the device.

70. The keyboard of claim 51, wherein the keyboard is usable without unfolding the device.

* * * * *

UNITED STATES PATENT AND TRADEMARK OFFICE
CERTIFICATE OF CORRECTION

PATENT NO. : 7,356,361 B1
APPLICATION NO. : 09/976841
DATED : April 8, 2008
INVENTOR(S) : Jeffrey C. Hawkins et al.

Page 1 of 1

It is certified that error appears in the above-identified patent and that said Letters Patent is hereby corrected as shown below:

Column 13, Line 12
Please delete "the" and insert --a--

Column 13, Line 12
Please delete "keys" and insert --key--

Signed and Sealed this

Twenty-first Day of October, 2008

A handwritten signature in black ink that reads "Jon W. Dudas". The signature is stylized, with a large loop for the letter 'J' and a distinct 'D'.

JON W. DUDAS
Director of the United States Patent and Trademark Office