



# USER MANUAL **SR20-D2**

Digital secondary standard pyranometer  
with Modbus RTU and 4-20 mA output



## Warning statements



Putting more than 30 Volt across the sensor wiring of the main power supply can lead to permanent damage to the sensor.



Putting more than 40 Volt across the sensor wiring of the current loop (4 to 20 mA) can lead to permanent damage to the sensor.



For proper instrument grounding: use SR20-D2 with its original factory-made SR20-D2 cable.



Using the same Modbus address for more than one device will lead to irregular behaviour of the entire network.



Your data request may need an offset of +1 for each SR20-D2 register number, depending on processing by the network master. Consult the manual of the device acting as the local master.

# Contents

<b>Warning statements</b>	<b>2</b>
<b>Contents</b>	<b>3</b>
<b>List of symbols</b>	<b>5</b>
<b>Introduction</b>	<b>6</b>
<b>1 Ordering and checking at delivery</b>	<b>9</b>
1.1 Ordering SR20-D2	9
1.2 Included items	9
1.3 Quick instrument check	10
<b>2 Instrument principle and theory</b>	<b>11</b>
<b>3 Specifications of SR20-D2</b>	<b>14</b>
3.1 Specifications of SR20-D2	14
3.2 Dimensions of SR20-D2	18
<b>4 Standards and recommended practices for use</b>	<b>19</b>
4.1 Classification standard	19
4.2 General use for solar radiation measurement	19
4.3 General use for sunshine duration measurement	19
4.4 Specific use for outdoor PV system performance testing	20
4.5 Specific use in meteorology and climatology	20
<b>5 Installation of SR20-D2</b>	<b>21</b>
5.1 Site selection and installation	21
5.2 Installation of the sun screen	22
5.3 Electrical connection of SR20-D2: wiring diagram	23
5.4 Grounding and use of the shield	23
5.5 Using SR20-D2's 4 to 20 mA output	24
5.6 Connecting to an RS-485 network	26
5.7 Connecting to a PC	28
<b>6 Communication with SR20-D2</b>	<b>29</b>
6.1 PC communication: Sensor Manager software	29
6.2 Network communication: function codes, registers, coils	34
6.3 Network communication: getting started	42
6.4 Network communication: example master request to SR20-D2	43
<b>7 Making a dependable measurement</b>	<b>46</b>
7.1 The concept of dependability	46
7.2 Reliability of the measurement	47
7.3 Speed of repair and maintenance	48
7.4 Uncertainty evaluation	48
<b>8 Maintenance and trouble shooting</b>	<b>51</b>
8.1 Recommended maintenance and quality assurance	51
8.2 Trouble shooting	52
8.3 Calibration and checks in the field	53
8.4 Data quality assurance	54
<b>9 Appendices</b>	<b>56</b>
9.1 Appendix on cable extension / replacement	56
9.2 Appendix on tools for SR20-D2	57
9.3 Appendix on spare parts for SR20-D2	58
9.4 Appendix on standards for classification and calibration	59
9.5 Appendix on calibration hierarchy	60
9.6 Appendix on meteorological radiation quantities	61
9.7 Appendix on ISO and WMO classification tables	62

9.8	Appendix on definition of pyranometer specifications	63
9.9	Appendix on terminology / glossary	64
9.10	Appendix on floating point format conversion	65
9.11	Appendix on function codes, register and coil overview	66
9.12	EC declaration of conformity	69

## List of symbols

### Quantities

	<b>Symbol</b>	<b>Unit</b>
Voltage output	U	V
Sensitivity	S	V/(W/m <sup>2</sup> )
Temperature	T	°C
Solar irradiance	E	W/m <sup>2</sup>
Solar radiant exposure	H	W·h/m <sup>2</sup>
Time in hours	h	h
Temperature coefficient	a	1/°C <sup>2</sup>
Temperature coefficient	b	1/°C
Temperature coefficient	c	-
Output of 4-20 mA current loop	I	A
Transmitted range of 4-20 mA output	r	W/m <sup>2</sup>

(see also appendix 9.6 on meteorological quantities)

### Subscripts

Not applicable

## Introduction

SR20-D2 is a solar radiation sensor of the highest category in the ISO 9060 classification system: secondary standard. SR20-D2 is designed for the solar PV industry, offering two types of commonly used irradiance outputs: digital via Modbus RTU over RS-485 and analogue 4-20 mA (current loop). These industry standards allow for easy data acquisition, easy read-out and error-free instrument exchange when using SR20-D2.

SR20-D2 measures the solar radiation received by a plane surface, in  $W/m^2$ , from a  $180^\circ$  field of view angle. It is employed where the highest measurement accuracy is required.

**This user manual covers SR20-D2 use. Specifications of SR20-D2 differ from those of model SR20. For SR20 use, consult the SR20 user manual.**

Individually tested for temperature and directional response, SR20-D2 is the most accurate digital secondary standard pyranometer available. Its benefits:

- Digital output: easy implementation and servicing
- Best-in-class temperature response  $< \pm 0.4\%$  ( $-30$  to  $+50\text{ }^\circ\text{C}$ ), best “zero offset a” and best calibration uncertainty
- Included in delivery as required by ISO 9060: test certificates for temperature response and directional response
- Re-calibration registers fully accessible to users

In order to improve overall measurement accuracy, Hukseflux effectively targeted two major sources of measurement uncertainty: calibration and “zero offset a”. In addition, SR20-D2 has a negligible temperature response. All are best in class. The temperature response of every individual instrument is tested and corrected onboard by the instrument electronics, using a second degree polynomial. SR20-D2’s low temperature dependence makes it the ideal candidate for use under very cold and very hot conditions.



**Figure 0.1** *SR20-D2 digital secondary standard pyranometer*

SR20-D2 pyranometer employs a state-of-the-art thermopile sensor with black coated surface, two domes and an anodised aluminium body. The connector, desiccant holder and sun screen fixation are very robust and designed for long term industrial use. SR20-D2 uses a high-end 24-bit A/D converter. All parts are specified for use across SR20-D2's entire rated operating temperature range. SR20-D2 offers two types of outputs: digital output via Modbus RTU over 2-wire RS-485 and analogue 4-20 mA output (current loop).

For communication between a PC and SR20-D2, the Hukseflux Sensor Manager software is included. It allows the user to plot and export data, and change the SR20-D2 Modbus address and its communication settings.



**Figure 0.2** User interface of the Sensor Manager

SR20-D2 is designed for use in SCADA (Supervisory Control And Data Acquisition) systems, supporting Modbus RTU (Remote Terminal Unit) protocol over RS-485. In these networks the sensor operates as a slave. SCADA systems are often implemented in photovoltaic solar energy (PV) systems and meteorological networks. Using SR20-D2 in a network is easy. Once it has the correct Modbus address and communication settings and is connected to a power supply, the instrument can be used in RS-485 networks. A typical network will request the irradiance (registers 2 + 3) and temperature data (register 6) every 1 second, and eventually store the averages every 60 seconds. How to issue a request, process the register content and convert it to useful data is described in the paragraphs about network communication. The user should have sound knowledge of the Modbus communication protocol when installing sensors in a network.

The instrument should be used in accordance with the recommended practices of ISO, WMO and ASTM.

The recommended calibration interval of pyranometers is 2 years. The registers containing the applied sensitivity and the calibration history of SR20-D2 are fully accessible for users. This allows the user to choose his own local calibration service. The same feature may be used for remotely controlled re-calibration of pyranometers in the field. Ask Hukseflux for information on this feature and on ISO and ASTM standardised procedures for field calibration.

Suggested use for SR20-D2:

- PV system performance monitoring
- all networks with regular instrument exchange
- scientific meteorological observations
- reference instrument for comparison
- extreme climates (tropical / polar)

The ASTM E2848 “Standard Test Method for Reporting Photovoltaic Non-Concentrator System Performance” (issued end 2011) confirms that a pyranometer is the preferred instrument for PV system performance monitoring. SR20-D2 pyranometer complies with the requirements of this standard. For more information, see our [pyranometer selection guide](#).

WMO has approved the “pyranometric method” to calculate sunshine duration from pyranometer measurements in WMO-No. 8, Guide to Meteorological Instruments and Methods of Observation. This implies that SR20-D2 may be used, in combination with appropriate software, to estimate sunshine duration. This is much more cost-effective than using a dedicated sunshine duration sensor. Ask for our application note.



# 1 Ordering and checking at delivery

## 1.1 Ordering SR20-D2

The standard configuration of SR20-D2 is with 5 metres cable.

Common options are:

- Longer cable (in multiples of 5 m). Specify total cable length.
- Five silica gel bags in an air-tight bag for SR20-D2 desiccant holder. Specify order number DC01.
- Adapted transmitted range for 4-20 mA output. Standard setting is 4 mA at 0 W/m<sup>2</sup> and 20 mA at 1600 W/m<sup>2</sup>. Specify preferred range setting.
- VU01 ventilation unit

## 1.2 Included items

Arriving at the customer, the delivery should include:

- pyranometer SR20-D2
- sun screen
- cable of the length as ordered
- calibration certificate matching the instrument serial number
- product certificate matching the instrument serial number (including temperature response test report and directional response test report for the individual instrument)
- Hukseflux Sensor Manager software on a USB flash drive
- any other options as ordered

Please store the certificates in a safe place.

### 1.3 Quick instrument check

A quick test of the instrument can be done by connecting it to a PC and installing the Sensor Manager software. See the chapters on installation and PC communication for directions.

1. At power-up the signal may have a temporary output level different from zero; an offset. Let this offset settle down.
2. Check if the sensor reacts to light: expose the sensor to a strong light source, for instance a 100 W light bulb at 0.1 m distance. The signal should read  $> 100 \text{ W/m}^2$  now. Darken the sensor either by putting something over it or switching off the light. The instrument irradiance output should go down and within one minute approach  $0 \text{ W/m}^2$ .
3. Remove the sun screen, (see chapter on installation of the sun screen). Inspect the bubble level.
4. Inspect the instrument for any damage.
5. Inspect if the humidity indicator is blue. Blue indicates dryness. The colour pink indicates it is humid: in the latter case replace the desiccant (see chapter on maintenance).
6. Check the instrument serial number as indicated by the software against the label on the instrument and against the certificates provided with the instrument.

## 2 Instrument principle and theory

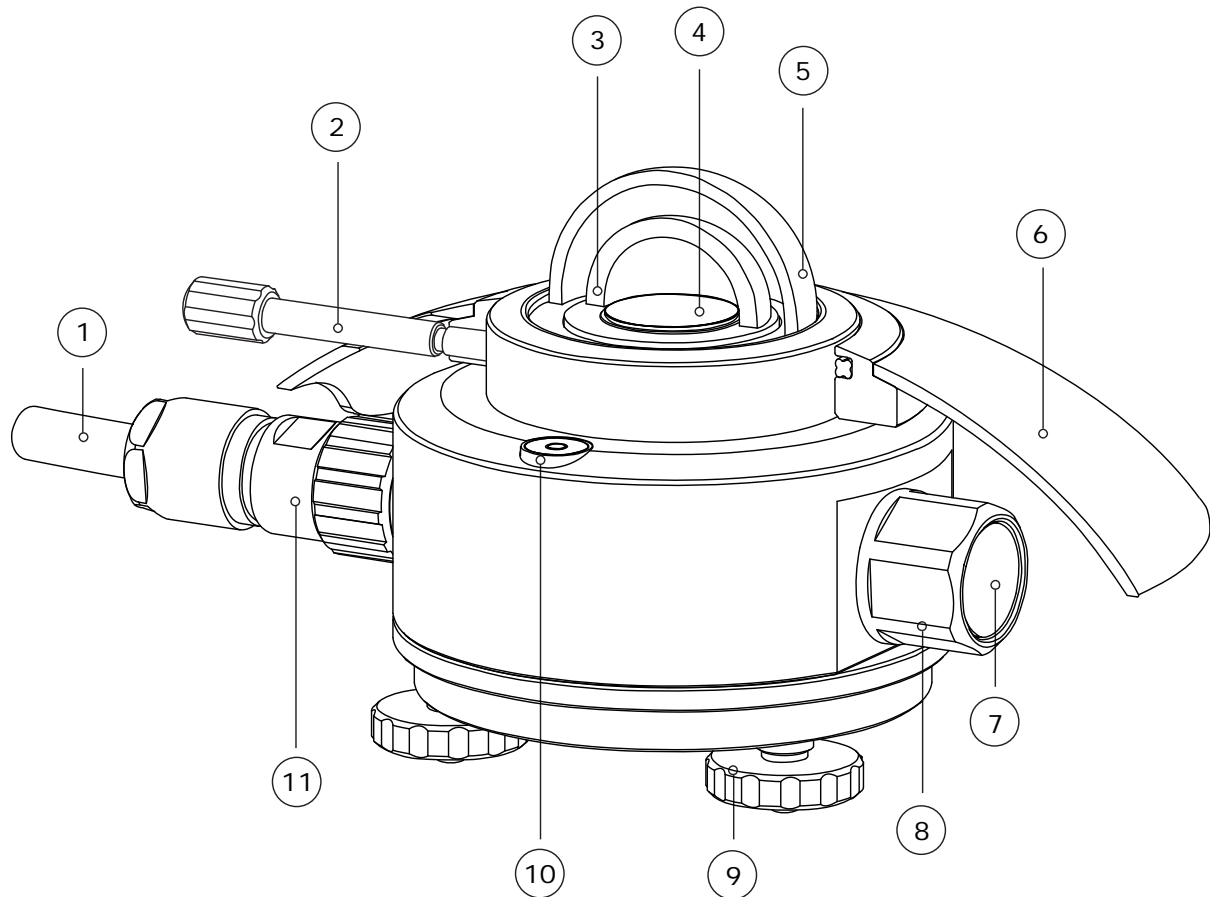

**Figure 2.1** Overview of SR20-D2:

- (1) cable (standard length 5 metres, optional longer cable)
- (2) fixation of sun screen (thumb screw)
- (3) inner dome
- (4) thermal sensor with black coating
- (5) outer dome
- (6) sun screen
- (7) humidity indicator
- (8) desiccant holder
- (9) levelling feet
- (10) bubble level
- (11) connector

SR20-D2's scientific name is pyranometer. A pyranometer measures the solar radiation received by a plane surface from a 180° field of view angle. This quantity, expressed in  $W/m^2$ , is called "hemispherical" solar radiation. The solar radiation spectrum extends roughly from 285 to  $3000 \times 10^{-9}$  m. By definition a pyranometer should cover that spectral range with a spectral selectivity that is as "flat" as possible.

In an irradiance measurement by definition the response to "beam" radiation varies with the cosine of the angle of incidence; i.e. it should have full response when the solar radiation hits the sensor perpendicularly (normal to the surface, sun at zenith, 0° angle of incidence), zero response when the sun is at the horizon (90° angle of incidence, 90° zenith angle), and 50 % of full response at 60° angle of incidence.

A pyranometer should have a so-called "directional response" (older documents mention "cosine response") that is as close as possible to the ideal cosine characteristic.

In order to attain the proper directional and spectral characteristics, a pyranometer's main components are:

- a thermal sensor with black coating. It has a flat spectrum covering the 200 to  $50000 \times 10^{-9}$  m range, and has a near-perfect directional response. The coating absorbs all solar radiation and, at the moment of absorption, converts it to heat. The heat flows through the sensor to the sensor body. The thermopile sensor generates a voltage output signal that is proportional to the solar irradiance.
- in case of SR20-D2 the analogue thermopile voltage is converted by the instrument electronics to a digital signal. In this process also the temperature dependence of the thermopile is compensated. SR20-D2 uses a high-end 24-bit A/D converter.
- a glass dome. This dome limits the spectral range from 285 to  $3000 \times 10^{-9}$  m (cutting off the part above  $3000 \times 10^{-9}$  m), while preserving the 180° field of view angle. Another function of the dome is that it shields the thermopile sensor from the environment (convection, rain).
- a second (inner) glass dome: For a secondary standard pyranometer, two domes are used, and not one single dome. This construction provides an additional "radiation shield", resulting in a better thermal equilibrium between the sensor and inner dome, compared to using a single dome. The effect of having a second dome is a strong reduction of instrument offsets.

Pyranometers can be manufactured to different specifications and with different levels of verification and characterisation during production. The ISO 9060 - 1990 standard, "Solar energy - specification and classification of instruments for measuring hemispherical solar and direct solar radiation", distinguishes between 3 classes; secondary standard (highest accuracy), first class (second highest accuracy) and second class (third highest accuracy).

From second class to first class and from first class to secondary standard, the achievable accuracy improves by a factor 2.

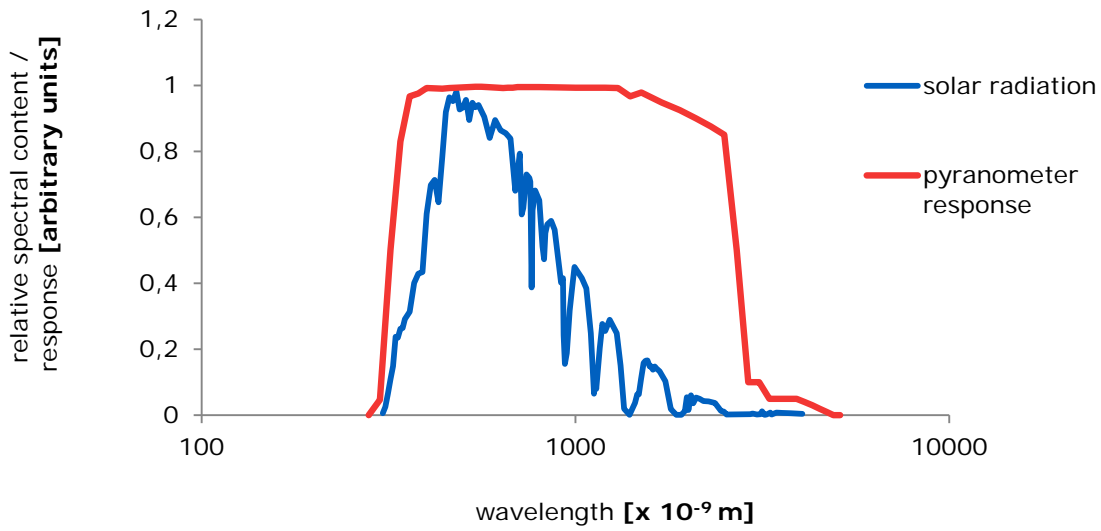

**Figure 2.2** Spectral response of the pyranometer compared to the solar spectrum. The pyranometer only cuts off a negligible part of the total solar spectrum.

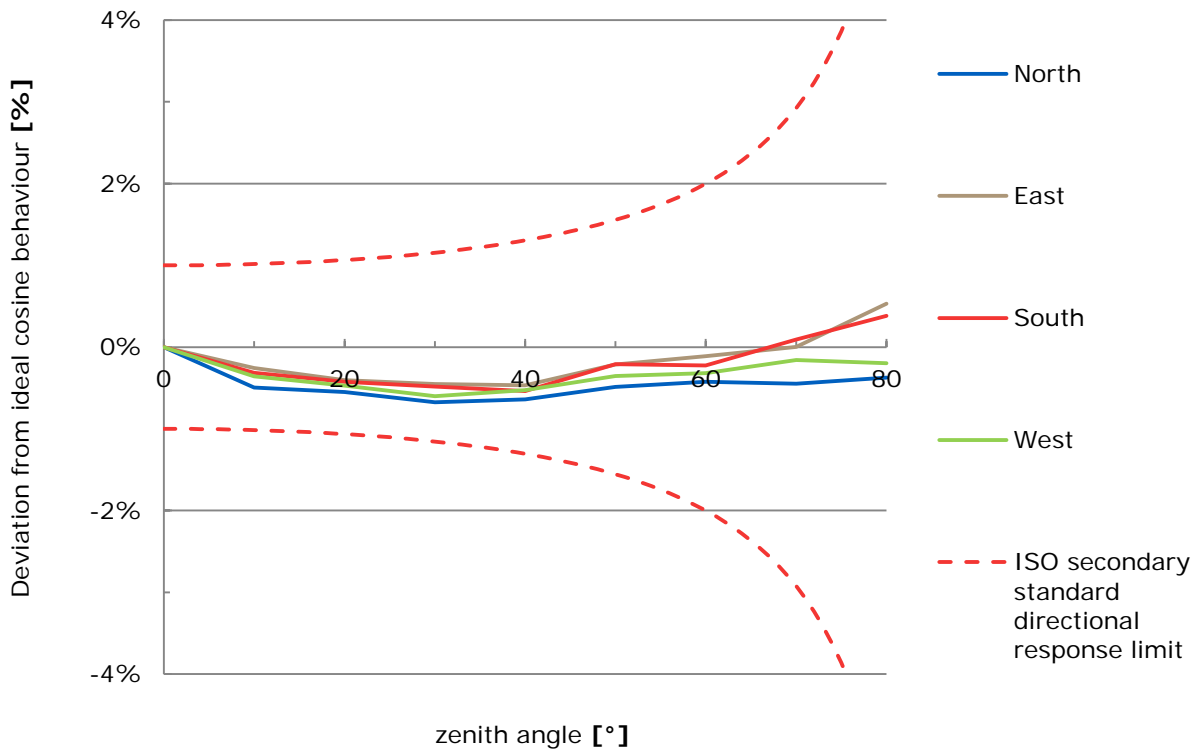

**Figure 2.3** Directional response of a SR20-D2 pyranometer of 4 azimuth angles, compared to secondary standard limits

## 3 Specifications of SR20-D2

### 3.1 Specifications of SR20-D2

SR20-D2 measures the solar radiation received by a plane surface from a 180° field of view angle. This quantity, expressed in  $W/m^2$ , is called “hemispherical” solar radiation. SR20-D2 offers irradiance in  $W/m^2$  as a digital output and as a 4-20 mA output. It must be used in combination with suitable power supply and a data acquisition system which uses the Modbus communication protocol over RS-485 or one that is capable of handling a 4-20 mA current loop signal. The instrument is classified according to ISO 9060 and should be used in accordance with the recommended practices of ISO, IEC, WMO and ASTM.

**Table 3.1.1** *Specifications of SR20-D2 (continued on next pages)*

<b>SR20-D2 MEASUREMENT SPECIFICATIONS: LIST OF CLASSIFICATION CRITERIA OF ISO 9060*</b>	
ISO classification (ISO 9060: 1990)	secondary standard pyranometer
WMO performance level (WMO-No. 8, seventh edition 2008)	high quality pyranometer
Response time (95 %)	3 s
Zero offset a (response to 200 $W/m^2$ net thermal radiation)	5 $W/m^2$ unventilated 2.5 $W/m^2$ ventilated
Zero offset b (response to 5 K/h change in ambient temperature)	< $\pm 2 W/m^2$
Non-stability	< $\pm 0.5$ % change per year
Non-linearity	< $\pm 0.2$ % (100 to 1000 $W/m^2$ )
Directional response	< $\pm 10 W/m^2$
Directional response test of individual instrument	report included
Spectral selectivity	< $\pm 3$ % (0.35 to 1.5 $\times 10^{-6} m$ )
Temperature response	< $\pm 0.4$ % (-30 to +50 °C)
Temperature response test of individual instrument	report included
Tilt response	< $\pm 0.2$ % (0 to 90 ° at 1000 $W/m^2$ )

\*For the exact definition of pyranometer ISO 9060 specifications see the appendix.

**Table 3.1.1** *Specifications of SR20-D2 (continued)*

<b>SR20-D2 ADDITIONAL SPECIFICATIONS</b>	
Measurand	hemispherical solar radiation
Measurand in SI radiometry units	irradiance in W/m <sup>2</sup>
Optional measurand	sunshine duration
Field of view angle	180 °
Output definition	running average over 4 measurements, refreshed every 0.1 s
Recommended data request interval	1 s, storing 60 s averages
Measurement range	-400 to 4000 W/m <sup>2</sup>
Zero offset steady state	< ± 0.5 W/m <sup>2</sup> at 20 °C < ± 0.8 W/m <sup>2</sup> (-40 to + 80 °C)
Zero offset dynamic / during power up	< 10 W/m <sup>2</sup> (nominal)
Measurement function / optional programming for sunshine duration	programming according to WMO guide paragraph 8.2.2
Internal temperature sensor	Analog Devices ADT7310 digital SPI temperature sensor
Rated operating temperature range	-40 to +80 °C
Spectral range (20 % transmission points)	285 to 3000 x 10 <sup>-9</sup> m
Standard governing use of the instrument	ISO/TR 9901:1990 Solar energy -- Field pyranometers -- Recommended practice for use ASTM G183 - 05 Standard Practice for Field Use of Pyranometers, Pyrheliometers and UV Radiometers
Standard cable length (see options)	5 m
Cable diameter	5.3 x 10 <sup>-3</sup> m
Chassis connector	M16 panel connector, male thread, 10-pole
Chassis connector type	HUMMEL AG 7.840.200.000 panel connector, front mounting, short version
Cable connector	M16 straight connector, female thread, 10-pole
Cable connector type	HUMMEL AG 7.810.300.00M straight connector, female thread, for cable 3 to 6 x 10 <sup>-3</sup> m, special version
Connector protection class	IP 67 / IP 69 K per EN 60 529 (connected)
Cable replacement	replacement cables with connector can be ordered separately from Hukseflux
Mounting	2 x M5 bolt at 65 x 10 <sup>-3</sup> m centre-to-centre distance on north-south axis, or 1 x M6 bolt at the centre of the instrument, connection from below under the bottom plate of the instrument
Levelling	bubble level and adjustable levelling feet are included
Levelling accuracy	< 0.1° bubble entirely in ring
Desiccant	two bags of silica gel, 0.5 g, (35 x 20) mm
Humidity indicator	blue when dry, pink when humid
IP protection class	IP 67
Gross weight including 5 m cable	1.2 kg
Net weight including 5 m cable	0.85 kg
Packaging	box of (200 x 135 x 225) mm
<b>HEATING</b>	
Heater	no heating

**Table 3.1.1** Specifications of SR20-D2 (started on previous pages)

<b>CALIBRATION</b>	
Calibration traceability	to WRR
Calibration hierarchy	from WRR through ISO 9846 and ISO 9847, applying a correction to reference conditions
Calibration method	indoor calibration according to ISO 9847, Type IIc
Calibration uncertainty	< 1.2 % (k = 2)
Recommended recalibration interval	2 years
Reference conditions	20 °C, normal incidence solar radiation, horizontal mounting, irradiance level 1000 W/m <sup>2</sup>
Validity of calibration	based on experience the instrument sensitivity will not change during storage. During use under exposure to solar radiation the instrument "non-stability" specification is applicable.
Adjustment after re-calibration	via a PC, as <i>power user</i> with the Sensor Manager software. Request "power user" status at the factory for sensitivity adjustment and for writing the calibration history data.
<b>MEASUREMENT ACCURACY AND RESOLUTION</b>	
Uncertainty of the measurement	statements about the overall measurement uncertainty can only be made on an individual basis. see the chapter on uncertainty evaluation
WMO estimate on achievable accuracy for daily sums (see appendix for a definition of the measurement conditions)	2 %
WMO estimate on achievable accuracy for hourly sums (see appendix for a definition of the measurement conditions)	3 %
Irradiance resolution	0.05 W/m <sup>2</sup>
Instrument body temperature resolution	7.8 x 10 <sup>-3</sup> °C
Instrument body temperature accuracy	± 0.5 °C
<b>DIGITAL</b>	
Digital output	irradiance in W/m <sup>2</sup> instrument body temperature in °C
Rated operating voltage range	5 to 30 VDC
Power consumption main supply	< 75 x 10 <sup>-3</sup> W at 12 VDC
Communication protocol	Modbus over 2-wire RS-485 half duplex
Transmission mode	RTU
System requirements for use with PC	Windows XP and later, USB or RS-232 (COM) port and connector, RS-485 / USB converter or RS-485 / RS-232 converter
Software requirements for use with PC	Java Runtime Environment – software available free of charge at <a href="http://www.java.com">http://www.java.com</a>
User interface on PC	Hukseflux Sensor Manager software supplied with the instrument on a USB flash drive for available software updates, please check <a href="http://www.hukseflux.com/page/downloads">http://www.hukseflux.com/page/downloads</a>
<b>4 TO 20 mA</b>	
4 to 20 mA output	irradiance in W/m <sup>2</sup>
Transmitted range	0 to 1600 W/m <sup>2</sup>
Output signal	4 to 20 x 10 <sup>-3</sup> A
Standard setting (see options)	4 x 10 <sup>-3</sup> A at 0 W/m <sup>2</sup> and 20 x 10 <sup>-3</sup> A at 1600 W/m <sup>2</sup>



**Table 3.1.1** *Specifications of SR20-D2 (started on previous pages)*

Principle of 4 to 20 mA output	2-wire current loop. note: 2 additional wires are needed for the main supply of the sensor
Rated operating voltage range of 4 to 20 mA output	5.5 to 40 VDC
Power consumption of main supply	$< 75 \times 10^{-3} \text{ W}$ at 12 VDC
Power consumption of 4 to 20 mA current loop	$< 40 \times 10^{-3} \text{ W}$ at 12 VDC with recommended 100 $\Omega$ shunt resistor (see chapter on using SR20-D2's 4-20 mA output)
<b>BACKWARDS COMPATIBILITY</b>	
SR20-D2 and SR20-D1	SR20-D2 is the successor of both model SR20-D1 and model SR20-TR. SR20-D2 is completely backwards compatible with SR20-D1: SR20-D1 users can use SR20-D2 without the need to change settings or wiring
<b>VERSIONS / OPTIONS</b>	
Adapted transmitted range 4 to 20 mA	can be adjusted at the factory upon request
Longer cable, in multiples of 5 m	option code = total cable length
<b>ACCESSORIES</b>	
Ventilation unit	VU01
Bags of silica gel for desiccant	set of 5 bags in an air tight bag option code = DC01

### 3.2 Dimensions of SR20-D2

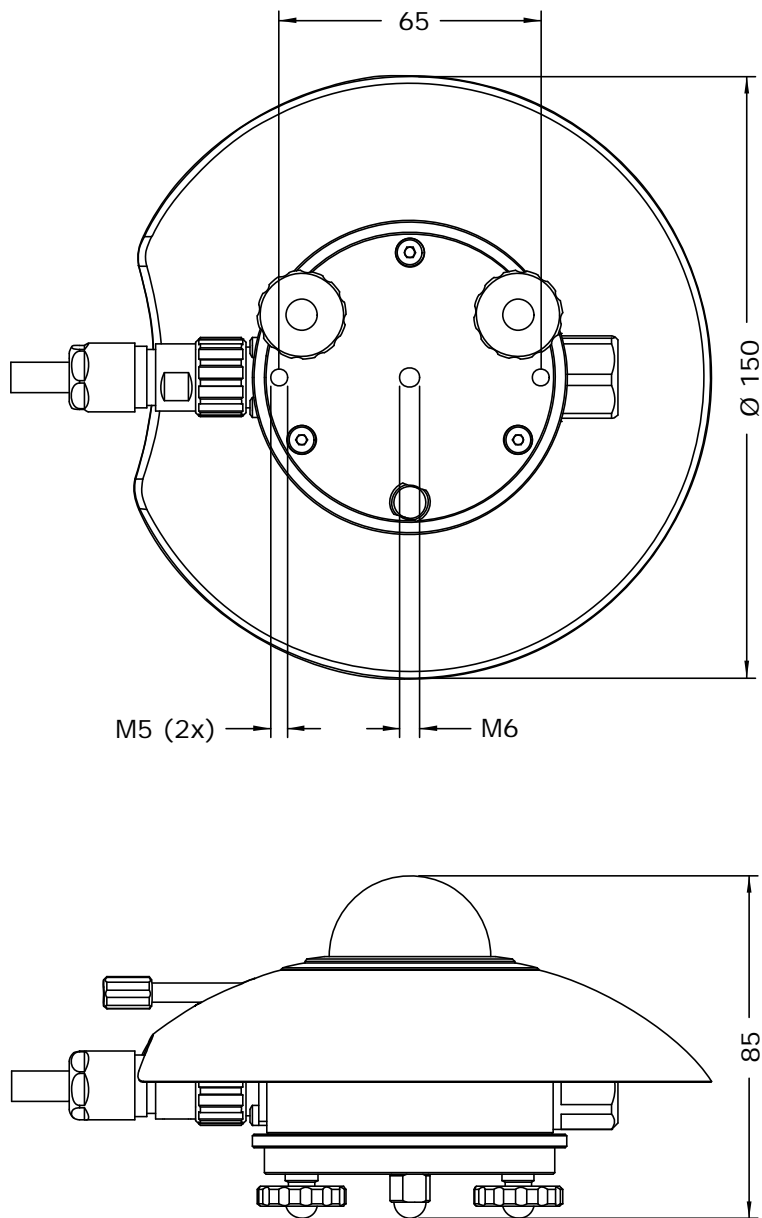

**Figure 3.2.1** Dimensions of SR20-D2 in  $\times 10^{-3}$  m.

## 4 Standards and recommended practices for use

Pyranometers are classified according to the ISO 9060 standard and the WMO-No. 8 Guide. In any application the instrument should be used in accordance with the recommended practices of ISO, IEC, WMO and / or ASTM.

### 4.1 Classification standard

**Table 4.1.1** *Standards for pyranometer classification. See the appendix for definitions of pyranometer specifications, and a table listing the specification limits.*

STANDARDS FOR INSTRUMENT CLASSIFICATION		
ISO STANDARD	EQUIVALENT ASTM STANDARD	WMO
ISO 9060:1990 Solar energy -- specification and classification of instruments for measuring hemispherical solar and direct solar radiation	Not available	WMO-No. 8; Guide to Meteorological Instruments and Methods of Observation, chapter 7, measurement of radiation, 7.3 measurement of global and diffuse solar radiation

### 4.2 General use for solar radiation measurement

**Table 4.2.1** *Standards with recommendations for instrument use in solar radiation measurement*

STANDARDS FOR INSTRUMENT USE FOR HEMISPHERICAL SOLAR RADIATION		
ISO STANDARD	EQUIVALENT ASTM STANDARD	WMO
ISO/TR 9901:1990 Solar energy -- Field pyranometers -- Recommended practice for use	ASTM G183 - 05 Standard Practice for Field Use of Pyranometers, Pyrheliometers and UV Radiometers	WMO-No. 8; Guide to Meteorological Instruments and Methods of Observation, chapter 7, measurement of radiation, 7.3 measurement of global and diffuse solar radiation

### 4.3 General use for sunshine duration measurement

According to the World Meteorological Organization (WMO, 2003), sunshine duration during a given period is defined as the sum of that sub-period for which the direct solar irradiance exceeds 120 W/m<sup>2</sup>.

WMO has approved the “pyranometric method” to estimate sunshine duration from pyranometer measurements (Chapter 8 of the WMO Guide to Instruments and Observation, 2008). This implies that a pyranometer may be used, in combination with appropriate software, to estimate sunshine duration. Ask for our application note.

**Table 4.3.1** *Standards with recommendations for instrument use in sunshine duration measurement*

---

**STANDARDS FOR INSTRUMENT USE FOR SUNSHINE DURATION**

---

WMO

---

WMO-No. 8; Guide to Meteorological Instruments and Methods of Observation, chapter 8, measurement of sunshine duration, 8.2.2 Pyranometric Method

---

#### 4.4 Specific use for outdoor PV system performance testing

SR20-D2 is very well applicable in outdoor PV system performance testing. See also Hukseflux model **SR12** “first class pyranometer for solar energy test applications”.

**Table 4.4.1** *Standards with recommendations for instrument use in PV system performance testing*

---

**STANDARDS ON PV SYSTEM PERFORMANCE TESTING**

---

IEC / ISO STANDARD	EQUIVALENT ASTM STANDARD
IEC 61724; Photovoltaic system performance monitoring – guidelines for measurement, data exchange and analysis	ASTM 2848-11; Standard Test Method for Reporting Photovoltaic Non-Concentrator System Performance
COMMENT: Allows pyranometers or reference cells according to IEC 60904-2 and -6. Pyranometer reading required accuracy better than 5% of reading (Par 4.1)	COMMENT: confirms that a pyranometer is the preferred instrument for outdoor PV testing. Specifically recommends a “first class” pyranometer (paragraph A 1.2.1.)
COMMENT: equals JISC 8906 (Japanese Industrial Standards Committee)	

---

#### 4.5 Specific use in meteorology and climatology

The World Meteorological Organization (WMO) is a specialised agency of the United Nations. It is the UN system’s authoritative voice on the state and behaviour of the earth’s atmosphere and climate. WMO publishes WMO-No. 8; Guide to Meteorological Instruments and Methods of Observation, in which a table is included on “level of performance” of pyranometers. Nowadays WMO conforms itself to the ISO classification system.

## 5 Installation of SR20-D2

### 5.1 Site selection and installation

**Table 5.1.1** *Recommendations for installation of pyranometers*

Location	the situation that shadows are cast on the instruments is usually not desirable. The horizon should be as free from obstacles as possible. Ideally there should be no objects between the course of the sun and the instrument.
Mechanical mounting / thermal insulation	preferably use connection by bolts to the bottom plate of the instrument. A pyranometer is sensitive to thermal shocks. Do not mount the instrument with the body in direct thermal contact to the mounting plate (so always use the levelling feet also if the mounting is not horizontal), do not mount the instrument on objects that become very hot (black coated metal plates).
Instrument mounting with 2 bolts	2 x M5 bolt at $65 \times 10^{-3}$ m centre to centre distance on north-south axis, connection from below under the bottom plate of the instrument.
Instrument mounting with one bolt	1 x M6 bolt at the centre of the instrument, connection from below under the bottom plate of the instrument.
Performing a representative measurement	the pyranometer measures the solar radiation in the plane of the sensor. This may require installation in a tilted or inverted position. The black sensor surface (sensor bottom plate) should be mounted parallel to the plane of interest. In case a pyranometer is not mounted horizontally or in case the horizon is obstructed, the representativeness of the location becomes an important element of the measurement. See the chapter on uncertainty evaluation.
Levelling	in case of horizontal mounting only use the bubble level and levelling feet. For inspection of the bubble level the sun screen must be removed.
Instrument orientation	by convention with the cable exit pointing to the nearest pole (so the cable exit should point north in the northern hemisphere, south in the southern hemisphere).
Installation height	in case of inverted installation, WMO recommends a distance of 1.5 m between soil surface and sensor (reducing the effect of shadows and in order to obtain good spatial averaging).

## 5.2 Installation of the sun screen

SR20-D2's sun screen can be installed and removed by using the dedicated thumb screw. See item 2 of the drawing below. The thumb screw can be turned without tools for fixation or loosening of the sun screen, as visualised below. Once the thumb screw has turned the sun screen loose, the screen can be lifted off manually. After removal the user may inspect the bubble level, item 10 of the drawing, and remove the cable / connector, item 11.

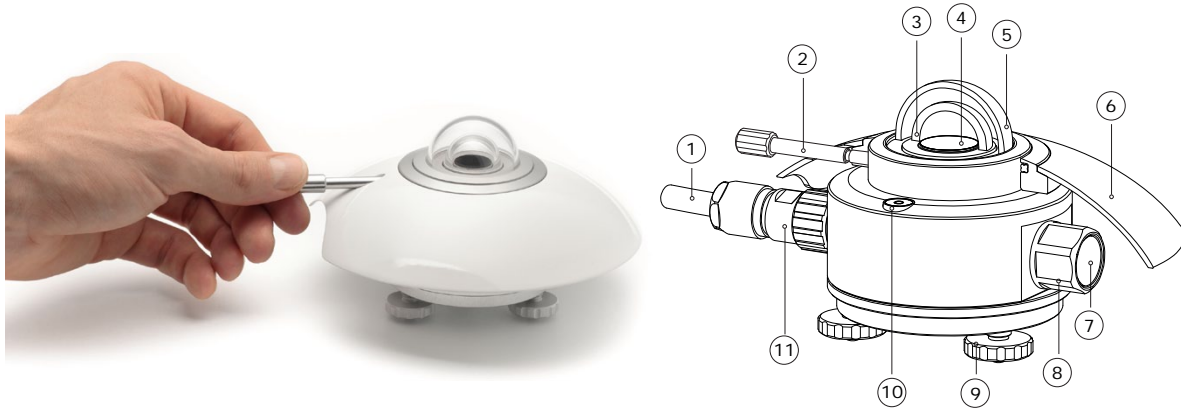

**Figure 5.2.1** Installation and removal of SR20-D2's sun screen

### 5.3 Electrical connection of SR20-D2: wiring diagram

The instrument must be powered by an external power supply, providing an operating voltage in the range from 5 to 30 VDC. This is the main power supply for the sensor, using the red and blue wires. Do not put more than 30 Volt across these wires. In addition, when using the 4 to 20 mA output (current loop), 5.5 to 40 VDC must be supplied to the designated pink and grey wires. Do not put more than 40 Volt across these wires. See chapter 5.5 for using SR20-D2's 4 to 20 mA output.

**Table 5.3.1** *Wiring diagram of SR20-D2*

PIN	WIRE	SR20-D2
2	Red	VDC [+] (main power supply +)
3	Pink	4 to 20 mA [+]
6	Blue	VDC [-] (main power supply ground)
8	Grey	4 to 20 mA [-]
1	Brown	not connected
4	Yellow	not connected
9	Black	shield (to instrument body)
7	White	RS-485 B / B' [+]
5	Green	RS-485 A / A' [-]

Note 1: pin 9 is the cable shield, which shields the signal wires and is connected to the instrument body. The body is typically connected to the mounting platform, which should be locally connected to ground. The shield is not the main power supply ground, which is at pin 6, VDC [-].

Note 2: at the connector-end of the cable, the shield is connected to the connector housing and also to pin 9.

### 5.4 Grounding and use of the shield

Grounding and shield use are the responsibility of the user. The cable shield (called shield in the wiring diagram) is connected to the aluminium instrument body via the connector. In most situations, the instrument will be screwed on a mounting platform that is locally grounded. In these cases the shield at the cable end should not be connected at all. When a ground connection is not obtained through the instrument body, for instance in laboratory experiments, the shield should be connected to the local ground at the cable end. This is typically the ground or low voltage of the power supply or the common of the network. In exceptional cases, for instance when both the instrument and a datalogger are connected to a small size mast, the local ground at the mounting platform is the same as the network ground. In such cases ground connection may be made both to the instrument body and to the shield at the cable end.

## 5.5 Using SR20-D2's 4 to 20 mA output

SR20-D2 gives users the option to use 4 to 20 mA output instead of its digital output. When using 4 to 20 mA output, please read this chapter first. When opting solely for SR20-D2's digital output, please continue with the next chapter.

Using the 4 to 20 mA output provided by SR20-D2 is easy. The instrument can be connected directly to commonly used datalogging systems. The irradiance,  $E$ , in  $W/m^2$  is calculated by measuring the SR20-D2 output, a small current  $I$ , subtracting  $4 \times 10^{-3}$  A from it, and then multiplying by the transmitted range  $r$ . The transmitted range is provided with SR20-D2 on its product certificate. By convention  $0 W/m^2$  irradiance corresponds with  $4 \times 10^{-3}$  A transmitter output current  $I$ . The transmitted range, which is the irradiance at output current of  $20 \times 10^{-3}$  A, and is typically  $1600 W/m^2$ . The transmitted range can be adjusted at the factory upon request.

The central equation governing SR20-D2 is:

$$E = r \cdot (I - 4 \times 10^{-3}) / (16 \times 10^{-3}) \quad \text{(Formula 5.5.1)}$$

SR20-D2's low temperature dependence makes it an ideal candidate for use under very cold and very hot conditions. The temperature dependence of every individual instrument is tested and supplied as a second degree polynomial.

The irradiance output provided by SR20-D2 is temperature corrected. All temperature corrections are applied internally by the instrument. The temperature coefficients  $a$ ,  $b$ , and  $c$  can be found on the product certificate of each instrument.

**Table 5.5.1** *Requirements for data acquisition and amplification equipment*

<p>Capability to</p> <ul style="list-style-type: none"> <li>- measure 4-20 mA or</li> <li>- measure currents or</li> <li>- measure voltages</li> </ul>	<p>SR20-D2 has a 4-20 mA output. There are several possibilities to handle this signal. It is important to realise that the signal wires not only act to transmit the signal but also act as power supply for the 4-20 mA current loop circuit. SR20-D2 operates on a supply voltage of 5 to 30 VDC. In addition, 5.5 to 40 VDC is needed for the 4-20 mA output. Do not use the same power supply for these voltages. Some dataloggers have a 4-20 mA input. In that case SR20-D2 can be connected directly to the datalogger. Some dataloggers have the capability to measure currents. In some cases the datalogger accepts a voltage input. Usually a <math>100 \Omega</math> precision resistor is used to convert the current to a voltage (this will then be in the 0.4 – to 2 VDC range). This resistor must be put in the - wire of the sensor. See next page and chapter 5.3 for electrical connections.</p>
--	--



See chapter 5.3 and the diagrams below for electrical connections to am- and voltmeters, when using SR20-D2's 4 to 20 mA output.

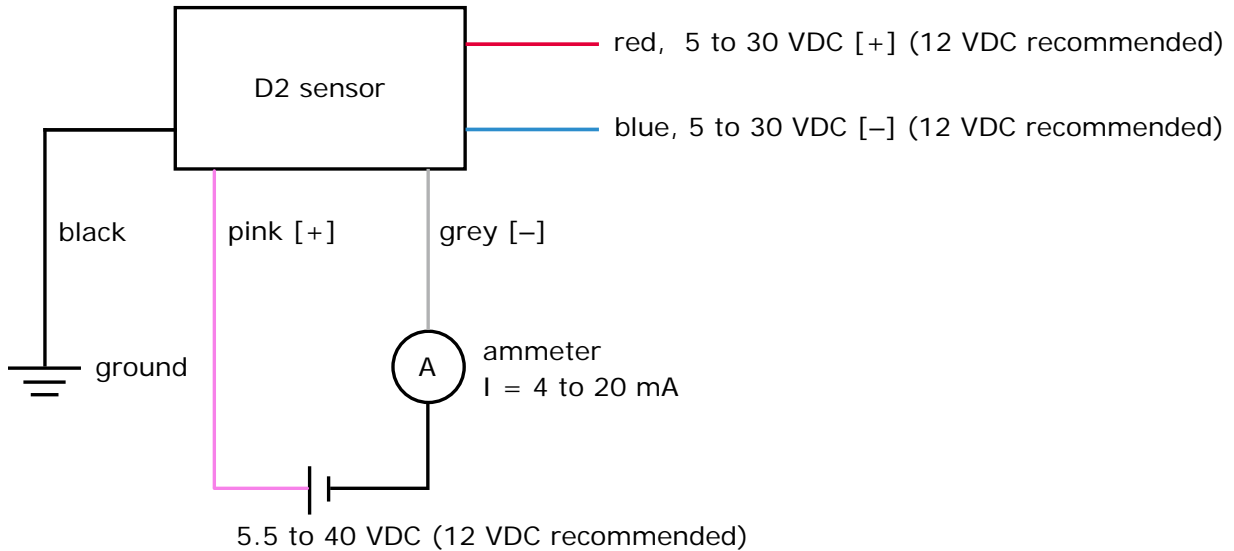

**Figure 5.5.1** Electrical diagram of the connection of SR20-D2 to a typical ammeter or datalogger with capacity to measure current signals. SR20-D2 operates on a supply voltage of 5 to 30 VDC. In addition, 5.5 to 40 VDC is needed for the 4 -20 mA function.

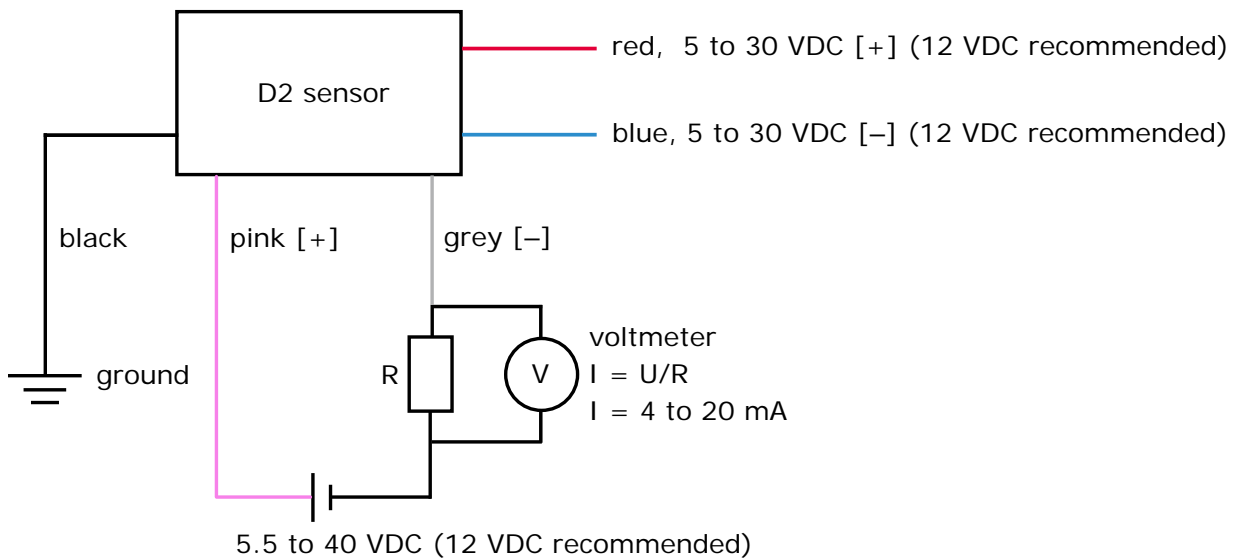

**Figure 5.5.2** Electrical diagram of the connection of SR20-D2 to a typical voltmeter or datalogger with the capacity to measure voltage signals. Usually a 100 Ω shunt resistor (R) is used to convert the current to a voltage. SR20-D2 operates on a supply voltage of 5 to 30 VDC. In addition, 5.5 to 40 VDC is needed for the 4 -20 mA function.

## 5.6 Connecting to an RS-485 network

SR20-D2 is designed for a two-wire (half-duplex) RS-485 network. In such a network SR20-D2 acts as a slave, receiving data requests from the master. An example of the topology of an RS-485 two-wire network is shown in the figure below. SR20-D2 is powered from 5 to 30 VDC. The power supply is not shown in the figure. The VDC [-] power supply ground must be connected to the common line of the network.

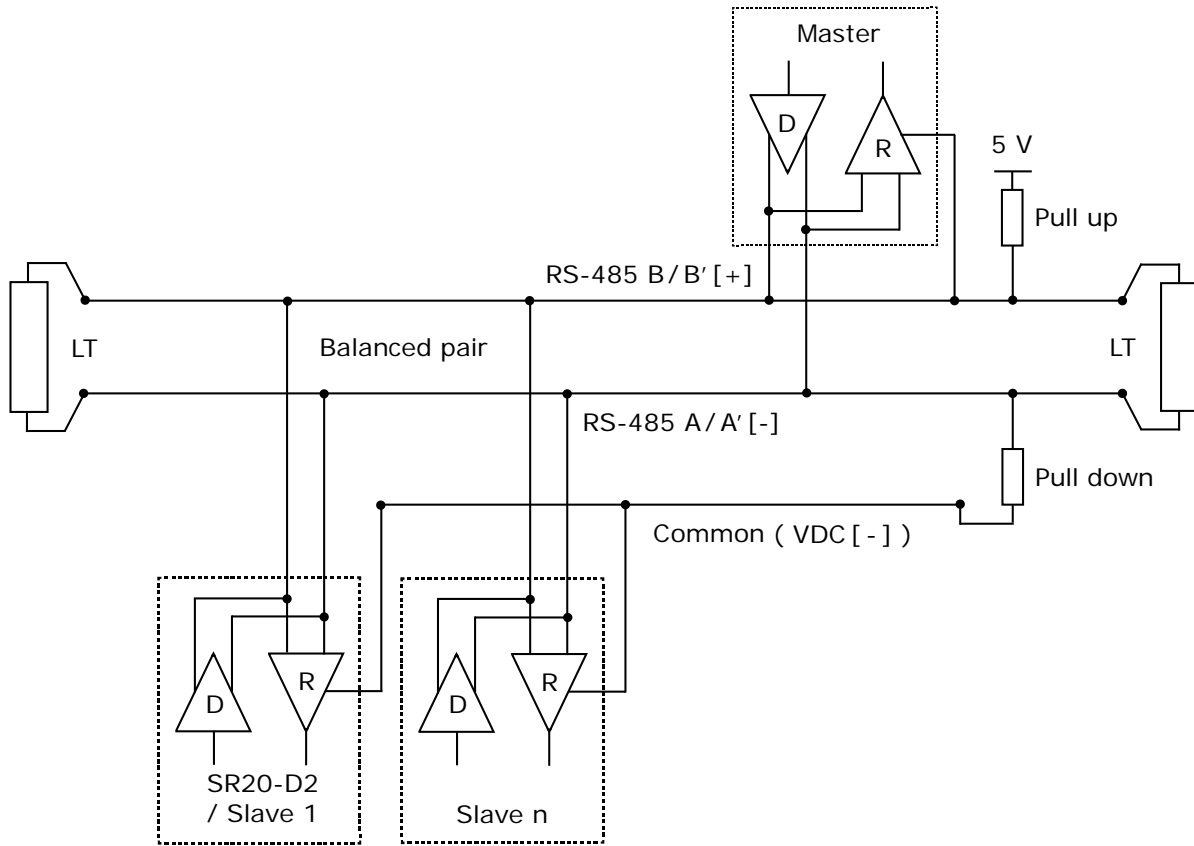

**Figure 5.6.1** Typical topology of a two-wire RS-485 network, figure adapted from: *Modbus over serial line specification and implementation guide V1.02 (www.modbus.org)*. The power supply is not shown in this figure.

After the last nodes in the network, on both sides, line termination resistors (LT) are required to eliminate reflections in the network. According to the EIA/TIA-485 standard, these LT have a typical value of 120 to 150  $\Omega$ . Never place more than two LT on the network and never place the LT on a derivation cable. To minimise noise on the network when no transmission is occurring, a pull up and pull down resistor are required. Typical values for both resistors are in the range from 650 to 850  $\Omega$ .

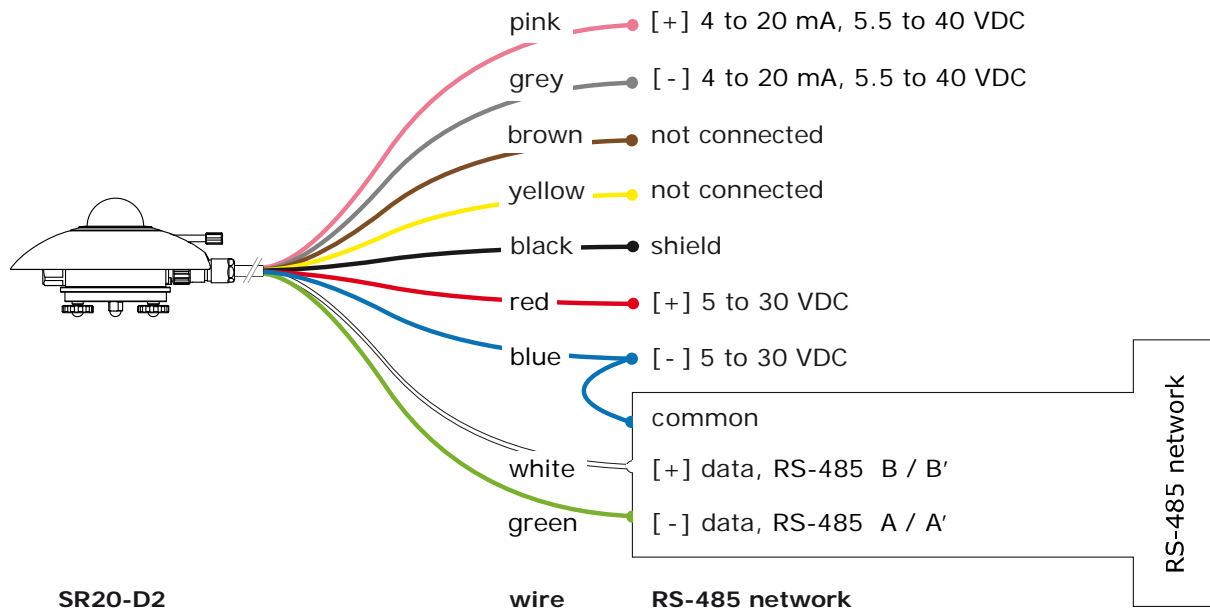
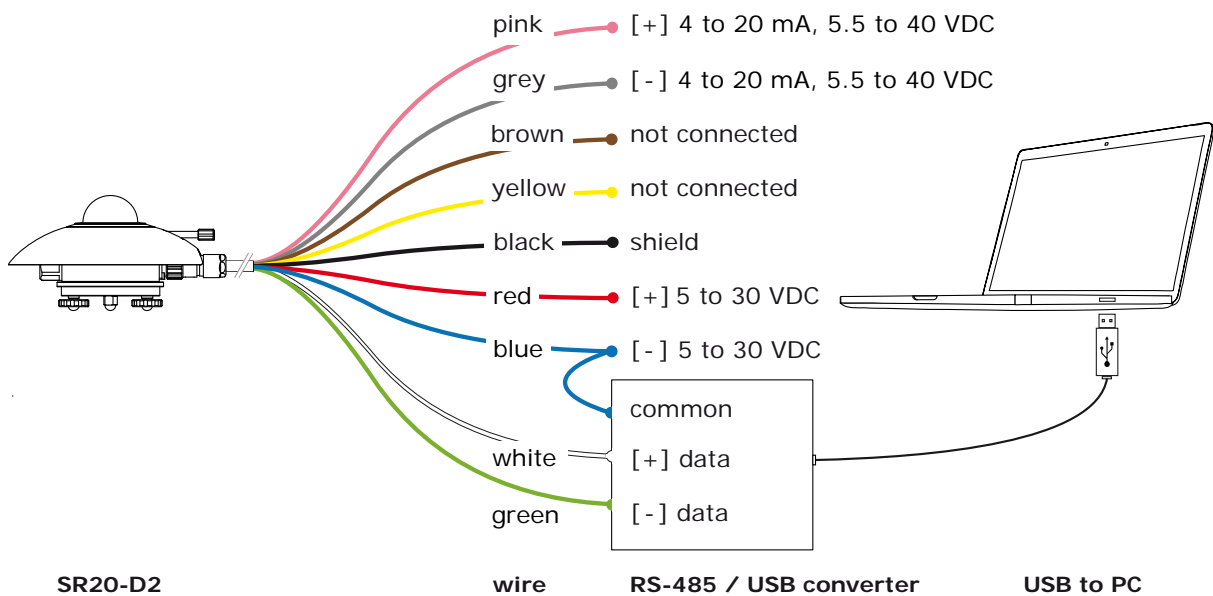

**Figure 5.6.2** Connection of SR20-D2 to an RS-485 network. SR20-D2 is powered by an external power supply of 5 to 30 VDC.

## 5.7 Connecting to a PC

SR20-D2 can be accessed via a PC. In that case communication with the sensor is done via the user interface offered by the Sensor Manager software (see the next chapters) or by another Modbus testing tool.

Depending on the available ports on the PC, either an RS-485 to USB converter or an RS-485 to RS-232 converter is used. The figure below shows how connections are made. The converter must have galvanic isolation between signal input and output to prevent static electricity or other high-voltage surges to enter the data lines. An external power supply is required to power the SR20-D2 (5 to 30 VDC). An RS-485 to USB converter is usually powered via the USB interface: in this case no external power is needed to feed the converter. If an RS-485 to RS-232 converter is used, this converter should be powered by an external source. This may be the same supply used for the SR20-D2.



**Figure 5.7.1** Connecting SR20-D2 to an RS-485 to USB converter and a PC

## 6 Communication with SR20-D2

### 6.1 PC communication: Sensor Manager software

SR20-D2 can be accessed via a PC. In that case the communication with the sensor is done via the user interface offered by the Sensor Manager software or by another Modbus testing tool. The Sensor Manager is supplied with the instrument on a USB flash drive. There are links to testing tools, paid or freeware, available at [www.modbus.org](http://www.modbus.org). This chapter describes the functionality of the Sensor Manager only.

The Hukseflux Sensor Manager software provides a user interface for communication between a PC and SR20-D2. It allows the user to locate, configure and test one or more SR20-D2's and to perform simple laboratory measurements using a PC. The Sensor Manager's most common use is for initial functionality testing and modification of the SR20-D2 Modbus address and communication settings. It is not intended for long-term continuous measurement purposes. The Sensor Manager software is supplied with the instrument on a USB flash drive. For available software updates of the Sensor Manager, please check [www.hukseflux.com/page/downloads](http://www.hukseflux.com/page/downloads).

#### 6.1.1 Installing the Sensor Manager

Running the Sensor Manager requires installation of the latest version of Java Runtime Environment software. Java Runtime Environment may be obtained free of charge from [www.java.com](http://www.java.com). The SR20-D2 specifications overview (Table 3.1.1) shows the system and software requirements for using a PC to communicate with SR20-D2. The Sensor Manager is supplied on a USB flash drive with the instrument.

- 1) Insert the USB flash drive and copy the folder "Hukseflux Sensor Manager" to a folder on a PC. For proper installation the user should have administrator rights for the PC.
- 2) Double-click "Hukseflux\_Sensor\_Manager.jar" in the folder "Hukseflux Sensor Manager". This will start up the Sensor Manager.

#### 6.1.2 Trouble shooting during Sensor Manager installation

- When Java Runtime Environment software is not installed, a Windows message comes up, displaying "the file "Hukseflux\_Sensor\_Manager.jar" could not be opened". The solution is to install Java Runtime Environment on the PC and try again.

### 6.1.3 Sensor Manager: main window

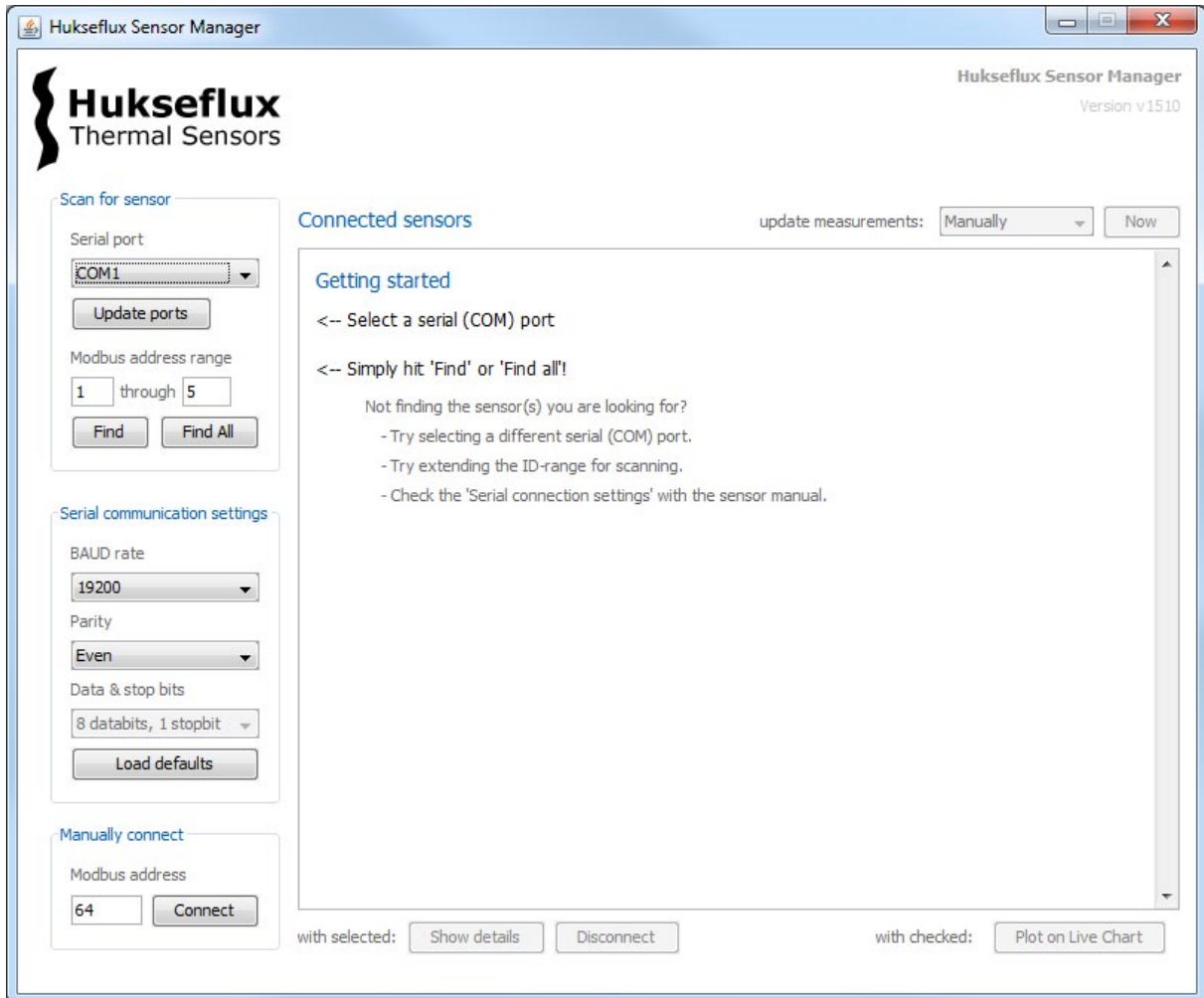

**Figure 6.1.3.1** Main window of the Sensor Manager

When the Sensor Manager is started and a SR20-D2 is connected to the PC, the user can communicate with the instrument.

If the instrument address and communication settings are known, the serial connection settings and the Modbus address can be entered directly. Clicking “Connect” will establish contact.

If the instrument address and communication settings are not known, the instrument is found by using the “Find” or “Find All” function. The Sensor Manager scans the specified range of Modbus addresses, however only using the “Serial connection settings” as indicated on screen. When only one sensor is connected, using “Find” is suggested because the operation stops when a sensor is found. “Find all” will continue a scan of the complete range of Modbus addresses and may take extra time.

If the “Find” or “Find all” operation does not find instruments, a dialog box opens, asking to confirm a scan of the address range using all possible communication settings. The time this operation takes, depends on the address range to be scanned. To complete a scan of 247 addresses will take over 15 minutes. When an instrument is found, a dialog box opens providing its serial number, Modbus address and communication settings. Communicating with the instrument is possible after changing the communication settings and Modbus address in the main window to the values of the instrument, and then clicking “Connect”.

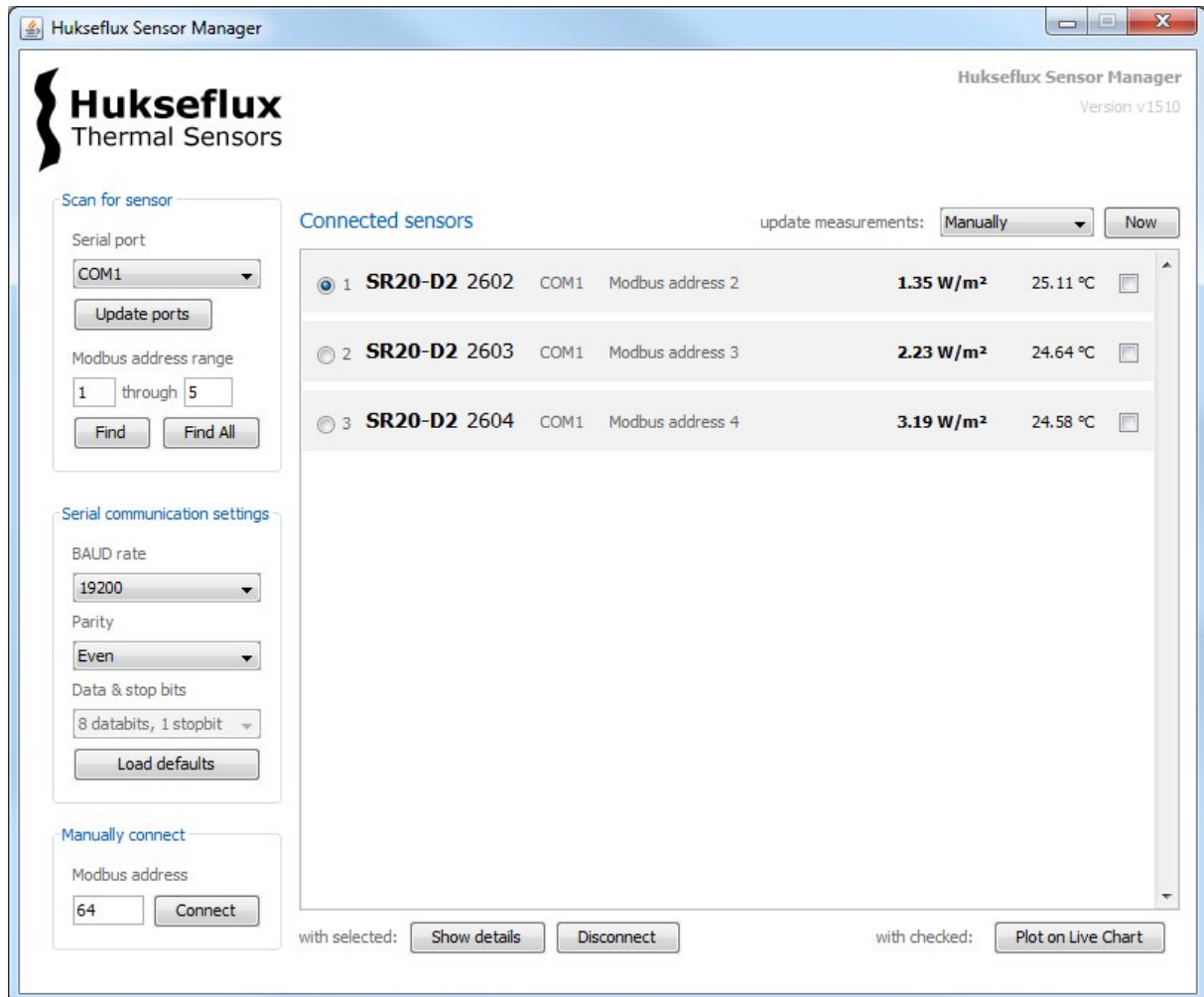

**Figure 6.1.3.2** Sensor Manager main window with three connected SR20-D2's

When an instrument is found, temperature and irradiance data are displayed. Updates are done manually or automatically. Automatic updates can be made every second, every 5 seconds or every minute.

#### 6.1.4 Sensor Manager: plotting data

When the “Plot on Live Chart” button in the lower right corner is clicked the “Plot window” opens. A live graph is shown of the measurement with the selected instrument.

The x-axis, time, is scaled automatically to display data of the complete measurement period. After checking the box "Show tail only", only the last minutes of measured data are displayed. When the "update interval" is 1 second, the "Show tail only" function is available after around 10 minutes of data collection. The y-axis displays the measured irradiance in W/m<sup>2</sup>. The Y-axis automatically scales to display the full measured range.

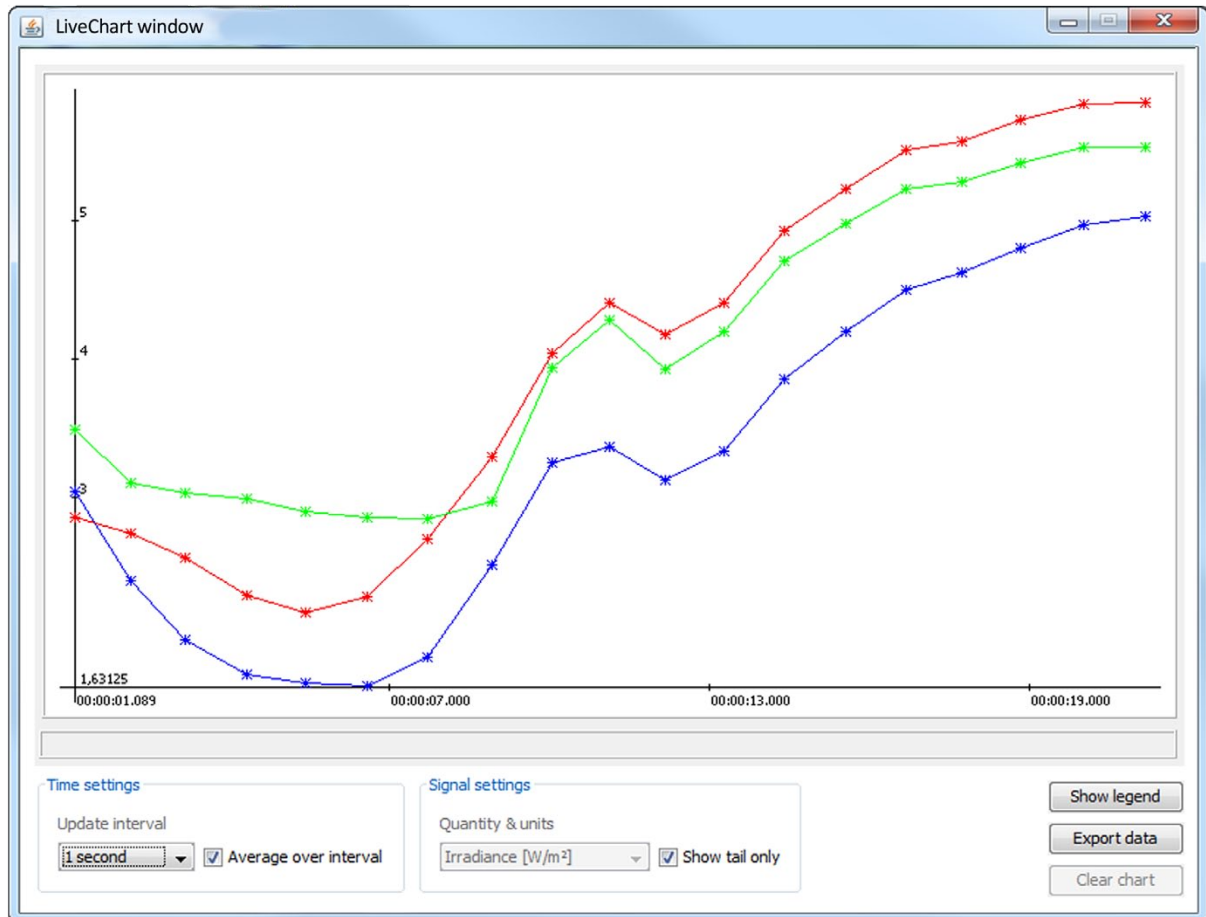
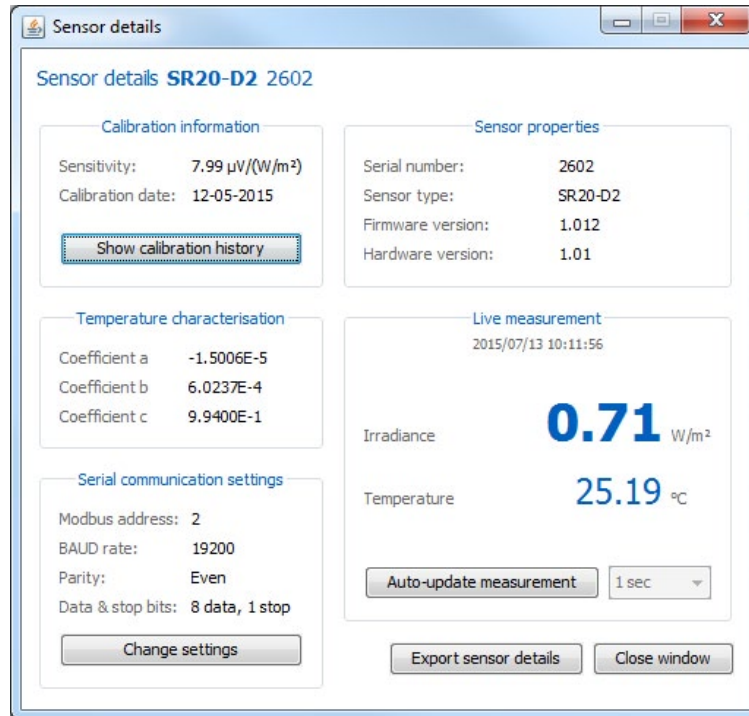

**Figure 6.1.4.1** Example of a SR20-D2 irradiance plot in the Sensor Manager

### 6.1.5 Sensor Manager: information about the instrument

The main window shows the "Show details" button, giving access to the "Sensor details" window. This window displays calibration results and calibration history, temperature coefficients and other properties of the selected instrument, as shown on the next page. The sensor serial number and all calibration information should match the information on the instrument label and on the product certificate.

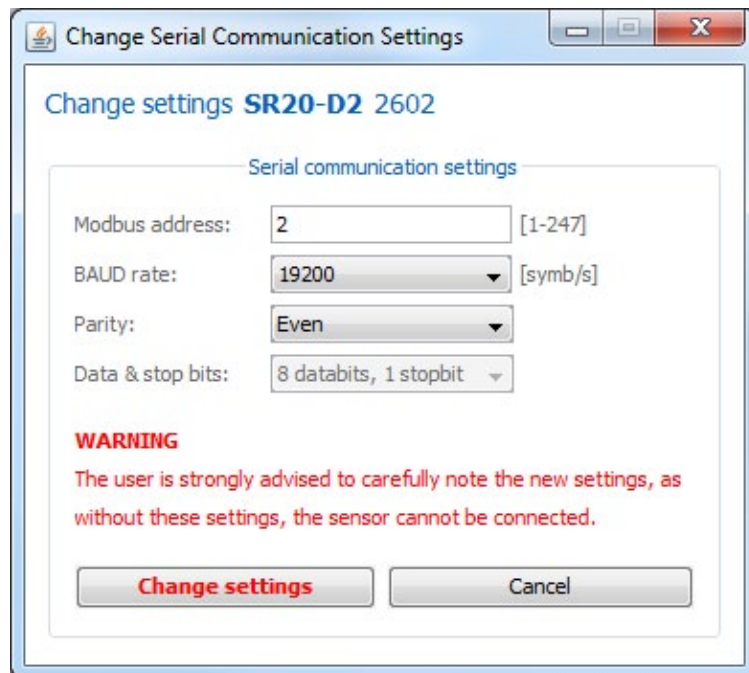



**Figure 6.1.5.1** Sensor details window in the Sensor Manager

### 6.1.6 Sensor Manager: changing Modbus address and communication settings

In the “Sensor details” window the “Change settings” function opens the “Change serial communication settings” window, as shown in the figure below.



**Figure 6.1.6.1** Change serial communication settings window in the Sensor Manager

When new communication settings or a new Modbus address are entered, these need to be confirmed by clicking “Change settings”. The instrument will then automatically restart. In case the “Change settings” function is not activated, the original settings remain valid. If the Modbus address is changed, the Sensor Manager will automatically reconnect with the instrument using the new address after restart.

### 6.1.7 Sensor Manager: adjustment of the sensitivity by power users

The Sensor Manager does not allow a “standard user” to change any settings that have a direct impact on the instrument output, i.e. the irradiance in W/m<sup>2</sup>. However, in case the instrument is recalibrated it is common practice that the sensitivity is adjusted, and that the latest result is added to the calibration history records. This can be done after obtaining a password and becoming a “power user”. Please contact the factory to obtain the password and to get directions to become a “power user”.

Example: During a calibration experiment, the result might be that SR20-D2 has an irradiance output in W/m<sup>2</sup> that is 990, whereas the standard indicates it should be 970. The SR20-D2 output is in this example 2.06 % too high. The original sensitivity of  $16.15 \times 10^{-6} \text{ V}/(\text{W}/\text{m}^2)$  ought to be changed to 16.48, using registers 41 + 42. The old calibration result is recorded in the calibration history file. In case there are still older results these are moved over to higher register numbers 63 to 81.

## 6.2 Network communication: function codes, registers, coils

*Warning: Using the same Modbus address for more than one device will lead to irregular behaviour of the entire network.* This chapter describes function codes, data model and registers used in the SR20-D2 firmware. Communication is organised according to the specifications provided by the Modbus Organization. These specifications are explained in the documents “Modbus application protocol v1.1b” and “Modbus over serial line v1.02”. These documents can be acquired free of charge at [www.modbus.org](http://www.modbus.org).

**Table 6.2.1** Supported Modbus function codes

SUPPORTED MODBUS FUNCTION CODES	
FUNCTION CODE (HEX)	DESCRIPTION
0x01	Read Coils
0x02	Read Discrete Inputs
0x03	Read Holding Registers
0x04	Read Input Register
0x05	Write Single Coil
0x06	Write Single Holding Register
0x0F	Write Multiple Coils
0x10	Write Multiple Registers

**Table 6.2.2** *Modbus data model*

MODBUS DATA MODEL		
PRIMARY TABLES	OBJECT TYPE	TYPE OF
Discrete input	Single bit	R
Coil	Single bit	R/W
Input register	16 bit word	R
Holding register	16 bit word	R/W

R = read only, W = write only, R/W = read / write

The instrument does not distinguish between *discrete input* and *coil*; neither between *input register* and *holding register*.

**Table 6.2.3** *Format of data*

FORMAT OF DATA	DESCRIPTION
U16	Unsigned 16 bit integer
S16	Signed 16 bit integer
U32	Unsigned 32 bit integer
S32	Signed 32 bit integer
Float	IEEE 754 32 bit floating point format
String	A string of ASCII characters

The data format includes *signed* and *unsigned* integers. The difference between these types is that a *signed* integer passes on negative values, which reduces the range of the integer by half. Up to five 16 bit registers can be requested in one request; if requesting six or more registers, multiple requests should be used.

If the format of data is a signed or an unsigned 32 bit integer, the first register received is the most significant word (MSW) and the second register is the least significant word (LSW). This way two 16 bit registers are reserved for a 32 bit integer. If the format of data is *float*, it is a 32 bit floating point operator and two 16 bit registers are reserved as well. Most network managing programs have standard menus performing this type of conversion. In case manual conversion is required, see the appendix on conversion of a floating point number to a decimal number. MSW and LSW should be read together in one request. This is necessary to make sure both registers contain the data of one internal voltage measurement. Reading out the registers with two different instructions may lead to the combination of LSW and MSW of two measurements at different points in time.

An Unsigned 32 bit integer can be calculated by the formula:  $(MSW \times 2^{16}) + LSW = U32$ . An example of such a calculation is available in the paragraph "Network communication: example master request to SR20-D2".



Your data request may need an offset of +1 for each SR20-D2 register number, depending on processing by the network master. Example: SR20-D2 register number 7 + master offset = 7 + 1 = master register number 8. Consult the manual of the device acting as the local master.

**Table 6.2.4** Modbus registers 0 to 11, measurements. For basic operation, Hukseflux recommends to read out registers 2 + 3 for solar radiation, register 6 for instrument body temperature and register 40 for the sensor serial number.

MODBUS REGISTERS 0-11				
REGISTER NUMBER	PARAMETER	DESCRIPTION OF CONTENT	TYPE OF	FORMAT OF DATA
0	Modbus address	Sensor address in Modbus network, default = 1	R/W	U16
1	Serial communication settings	Sets the serial communication, default = 5	R/W	U16
2 + 3	Irradiance (temperature compensated signal)	Temperature compensated signal in $\times 0.01 \text{ W/m}^2$	R	S32
4 + 5	Irradiance (uncompensated signal)	Uncompensated signal in $\times 0.01 \text{ W/m}^2$	R	S32
6	Sensor body temperature	In $\times 0.01 \text{ }^\circ\text{C}$	R	S16
7	Sensor electrical resistance	In $\times 0.1 \text{ } \Omega$	R	U16
8	Scaling factor irradiance	Default = 100	R	U16
9	Scaling factor temperature	Default = 100	R	U16
10 + 11	Sensor voltage output	In $\times 10^{-9} \text{ V}$	R	S32
12 to 31	Factory use only			

Register 0, *Modbus address*, contains the Modbus address of the sensor. This allows the Modbus master to detect the slave, SR20-D2, in its network. The address can be changed; the value of the address must be between 1 and 247. The default Modbus address is 1.

Note: The sensor needs to be restarted before changes become effective.

Register 1, *Serial communication settings*, is used to enter the settings for baud rate and the framing of the serial data transfer. Default setting is setting number 5: *19200 baud, 8 data bits, even parity and 1 stop bit*. Setting options are shown in the table below.

Note: The sensor needs to be restarted before changes become effective.

**Table 6.2.5** *Setting options of register 1*

SETTING OPTIONS				
SETTING NUMBER	BAUD RATE	DATABITS	STOPBITS	PARITY
1	9600	8	1	none
2	9600	8	1	even
3	9600	8	1	odd
4	19200	8	1	none
5 (= default)	19200	8	1	even
6	19200	8	1	odd
10	38400	8	1	none
11	38400	8	1	even
12	38400	8	1	odd
16	115200	8	1	none
17	115200	8	1	even
18	115200	8	1	odd

Register 2 + 3, *Irradiance (temperature compensated signal)*, provides the temperature compensated solar radiation output in 0.01 W/m<sup>2</sup>. The value given must be divided by 100 to get the value in W/m<sup>2</sup>. Hukseflux recommends using this data to achieve the highest accuracy. MSW and LSW should be read together in one request.

Register 4 + 5, *Irradiance (uncompensated signal)*. *Use for comparison purposes only.* Provides the sensor output in 0.01 W/m<sup>2</sup>, not compensated for temperature dependence. The data must be divided by 100 to get the value in W/m<sup>2</sup>. Hukseflux recommends not to use this data. MSW and LSW should be read together in one request.

Register 6, *Instrument body temperature*, provides the temperature of the instrument body in 0.01 °C. The data must be divided by 100 to achieve the value in °C.

Register 7, *Sensor electrical resistance*, sensor resistance in 0.1 Ω. The data needs to be divided by 10 to get the value in Ω. This register returns a 0 by default. To read the resistance, first a measurement has to be performed. This can be done by writing 0xFF00 to coil 2. Hukseflux recommends to use this function only when necessary for diagnostics in case of sensor failure.

Register 8, *Scaling factor irradiance*, default scaling factor is 100

Register 9, *Scaling factor temperature*, default scaling factor is 100.

Register 10, *Sensor voltage output*, sensor voltage output signal of the thermopile in x 10<sup>-9</sup> V.

**Table 6.2.6** Modbus registers 32 to 62, sensor and calibration information

MODBUS REGISTERS 32-62				
REGISTER NUMBER	PARAMETER	DESCRIPTION OF CONTENT	TYPE OF	FORMAT OF DATA
32 to 35	Sensor model	Part one of sensor description	R	String
36 to 39	Sensor model	Part two of sensor description	R	String
40	Sensor serial number		R	U16
41 + 42	Sensor sensitivity	$\ln \times 10^{-6} \text{ V}/(\text{W}/\text{m}^2)$	R	Float
43	Response time	$\ln \times 0.1 \text{ s}$	R	U16
44	Sensor resistance	$\ln \times 0.1 \Omega$	R	U16
45	Reserved	Always 0	R	U16
46 + 47	Sensor calibration date	Calibration date of the sensor in YYYYMMDD	R	U32
48 to 60	Factory use			
61	Firmware version		R	U16
62	Hardware version		R	U16

Register 32 to 39, *Sensor model*, String of 8 registers. This register will return 8 numbers, which correspond with ASCII characters.

Register 40, *Sensor serial number*

Register 41 + 42, *Sensor sensitivity*, the sensitivity of the sensor in  $\times 10^{-6} \text{ V}/(\text{W}/\text{m}^2)$ . Format of data is *float*,

Register 43, *Response time*, the response time of the sensor as measured in the factory in  $\times 0.1 \text{ s}$ . The value must be divided by 10 to get the value in s.

Register 44, *Sensor electrical resistance*, returns the electrical resistance measured during the sensor calibration. The resistance is in  $\times 0.1 \Omega$  and must be divided by 10 to get the value in  $\Omega$ .

Register 46 + 47, *Sensor calibration date*, last sensor calibration date, from which the sensitivity in register 41 and 42 was found, in YYYYMMDD.

Register 61, *Firmware version*.

Register 62, *Hardware version*.

**Table 6.2.7** Modbus registers 63 to 81, calibration history

MODBUS REGISTERS 63-81				
REGISTER NUMBER	PARAMETER	DESCRIPTION OF CONTENT	TYPE OF	FORMAT OF DATA
63 + 64	Sensor sensitivity history 1	In $\times 10^{-6}$ V/(W/m <sup>2</sup> ) Default value is 0	R	Float
65 + 66	Calibration date history 1	Former calibration date of the sensor in YYYYMMDD Default value is 0	R	U32
67 + 68	Sensor sensitivity history 2	See register 63 + 64	R	Float
69 + 70	Calibration date history 2	See register 65 + 66	R	U32
71 + 72	Sensor sensitivity history 3	See register 63 + 64	R	Float
73 + 74	Calibration date history 3	See register 65 + 66	R	U32
75 + 76	Sensor sensitivity history 4	See register 63 + 64	R	Float
77 + 78	Calibration date history 4	See register 65 + 66	R	U32
79 + 80	Sensor sensitivity history 5	See register 63 + 64	R	Float
81 + 82	Calibration date history 5	See register 65 + 66	R	U32

Register 63 to 82: Only accessible for writing by Sensor Manager *power users*: *power users* can write calibration history to registers 63 to 82. If default values are returned, no re-calibration has been written. Last calibration sensitivity and calibration date are available in register 41 + 42 and 46 + 47 respectively.

**Table 6.2.8** Modbus registers 83 to 85, directional response characterisation data

MODBUS REGISTERS 83-85				
REGISTER NUMBER	PARAMETER	DESCRIPTION OF CONTENT	TYPE OF	FORMAT OF DATA
83 + 84	Directional response measurement date	Directional response measurement date in YYYYMMDD	R	U32
85	Directional response measurement employee		R	U16

Register 83 to 85, these registers are for reference purposes.

**Table 6.2.9** Modbus registers 86 to 95, temperature response characterisation data

MODBUS REGISTERS 86-95				
REGISTER NUMBER	PARAMETER	DESCRIPTION OF CONTENT	TYPE OF	FORMAT OF DATA
86	Temperature response	In x 0.01 %	R	S16
87 + 88	Polynomial temperature coefficient a		R	Float
89 + 90	Polynomial temperature coefficient b		R	Float
91 + 92	Polynomial temperature coefficient c		R	Float
93 + 94	Temperature response characterisation measurement date	Temperature response characterisation measurement date of the sensor in YYYYMMDD.	R	U32
95	Temperature response characterisation measurement employee		R	U16

Register 86 to 95, these registers are for reference purposes.



Please note that if your data request needs an offset of +1 for each SR20-D2 register number, depending on processing by the network master, this offset applies to coils as well. Consult the manual of the device acting as the local master.

**Table 6.2.10** Modbus registers 96 to 99, humidity sensor information

MODBUS REGISTERS 96-99				
REGISTER NUMBER	PARAMETER	DESCRIPTION OF CONTENT	TYPE OF	FORMAT OF DATA
96 + 97	Factory use			
98	Humidity	In x 0.01 %	R	U16
99	Humidity temperature	In x 0.01 °C	R	S16

Register 98, *Humidity*, provides the relative humidity within the instrument. The value must be divided by 100 to get the value in %.

Register 99, *Humidity temperature*, the temperature measured by the humidity sensor. The value must be divided by 100 to get the value in °C.



**Table 6.2.11** *Coils*

COILS				
COIL	PARAMETER	DESCRIPTION	TYPE OF	OBJECT TYPE
0	Restart	Restart the sensor	W	Single bit
1	Reserved			
2	Check	Measure sensor electrical resistance	W	Single bit

Coil 0, *Restart*, when 0xFF00 is written to this coil the sensor will restart. If applied, a new Modbus address or new serial settings will become effective.

Coil 2, *Check*, when 0xFF00 is written to this coil the internal electronics will measure the electrical resistance of the thermopile. After the measurement, a new value will be written into register 7. Requesting to write this coil with a high repetition rate will result in irregular behaviour of the sensor; the check must be executed as an exceptional diagnostics routine only.

### 6.3 Network communication: getting started

Once it has the correct Modbus address and communication settings, SR20-D2 can be connected directly to an RS-485 network and a power supply. How to physically connect a sensor as a slave in a Modbus network is shown in the figure below. In such a connection the sensor is powered via an external power supply of 5 to 30 VDC. When the sensor is screwed onto a grounded mounting plate, which is usually the case, the shield is not connected to ground at the cable end.

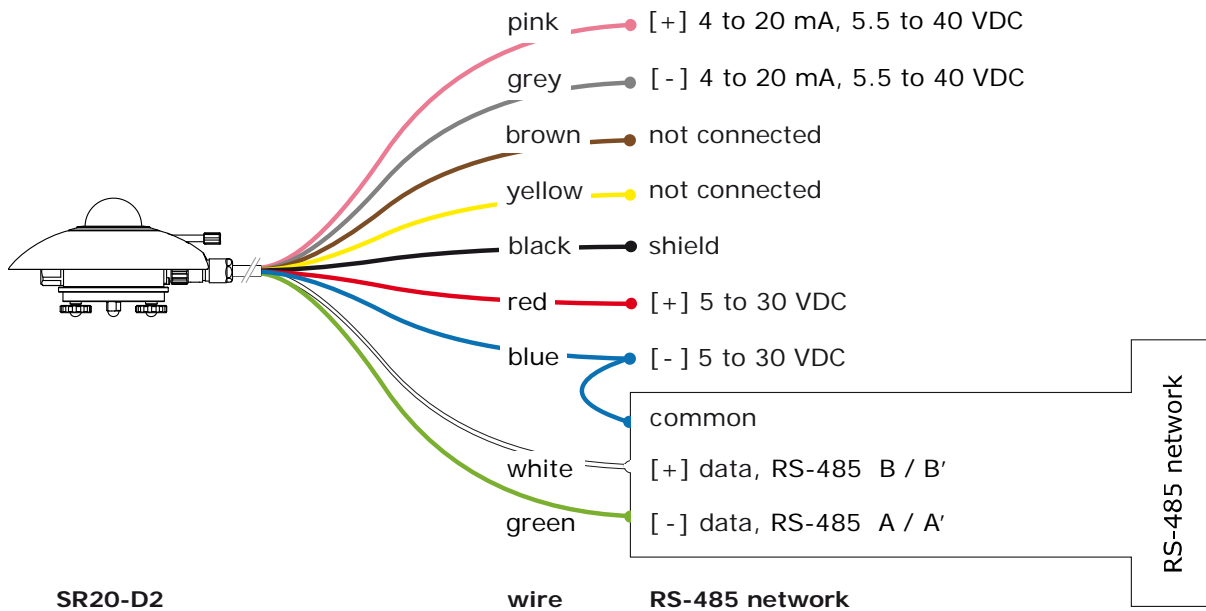

**Figure 6.3.1** Connecting SR20-D2 to a typical RS-485 network

Installing a SR20-D2 in the network also requires configuring the communication for this new Modbus device. This usually consists of defining a request that can be broadcast by the master. If the SR20-D2 is not already defined as a standard sensor type on the network, contact the supplier of the network equipment to see if a library file for the SR20-D2 is available.

Typical operation requires the master to make a request of irradiance data in registers 2 + 3, sensor temperature in register 6, and the sensor serial number in register 40 every 1 second, and store the 60 second averages. The data format of register 2 + 3 is a signed 32 bit integer and the temperature in register 6 is a signed 16 bit integer.

Up to five 16 bit registers can be requested in one request. In case six or more registers are requested in just one request, SR20-D2 will not respond. If requesting six or more registers, multiple requests should be used: SR20-D2 will respond as expected.

### 6.3.1 Adapting Modbus address and communication settings

Setting the instrument address and baud rate can be done in different ways:

- by connecting the sensor to the PC and using the Sensor Manager;
- by connecting the sensor to the PC and using another Modbus testing tool. There are links to different solutions available at [www.modbus.org](http://www.modbus.org);
- by using the available network user interface software.

The Modbus address is stored in register 0 and has a default value of 1. A user may change the address to a value in the range of 1 to 247. The address value must be unique in the network. The communication settings are stored in register 1. The default setting is setting number 5 representing a communication with 19200 baud, even parity bit, 8 data bits and 1 stop bit. After a new address or communication setting is written the sensor must be restarted. This can be done by writing 0xFF00 to coil 0.

## 6.4 Network communication: example master request to SR20-D2

Normal sensor operation consists of requesting the output of registers 2 + 3; the temperature compensated solar radiation. For quality assurance also the sensor serial number, register 40 and the temperature in register 6, are useful.

In this example a SR20-D2 has address 64. The example requests the solar radiation (temperature compensated) register 2 + 3, sensor serial number, register 40, and the temperature of the instrument register 6. The values are represented in hexadecimals.

Note: 32 bit data are represented in 2 registers. MSW and LSW should be read together in one request.

Request for solar radiation, register 2 + 3:

Master Request:

[40] [03] [00][00] [00][04] [4B][18]

[40] = Modbus slave address, decimal equivalent = 64

[03] = Modbus function; 03 Read holding registers

[00][00] = Starting register, the master requests data starting from register 0.

[00][04] = Length, the number of registers the master wants to read. 4 registers

[4B][18] = CRC, the checksum of the transmitted data

Sensor response:

[40] [03] [08] [00][40] [00][05] [00][01] [7C][4F] [79][DA]

[40] = Modbus slave address, decimal equivalent = 64

[03] = Modbus function

[08] = Number of bytes returned by the sensor. 8 bytes transmitted by the sensor

[00][40] = Register 0; Modbus address

[00][05] = Register 1; Serial settings, 19200 baud, 8 data bits, even parity bit, 1 stop bit

[00][01] = Register 2; Temperature compensated signal, Most Significant Word (MSW). Decimal equivalent = 1

[7C][4F] = Register 3; Temperature compensated signal, Least Significant Word (LSW) = Decimal equivalent = 31823

[79][DA] = CRC, the checksum of the transmitted data

Together, register 2 and 3 are representing the temperature compensated solar radiation output measured by the SR20-D2. The MSW is in register 2 and the LSW in 3. The output has to be calculated by the formula:  $((MSW \times 2^{16}) + LSW)/100$ .

In this example the result is:  $((2^{16} \times 1) + 31823)/100 = 973.59 \text{ W/m}^2$

Request for body temperature, register 6:

Master Request:

[40][03][00][06][00][01][6B][1A]

[40] = Modbus Slave address

[03] = Modbus function

[00][06] = Start register

[00][01] = Number of registers

[6B][1A] = CRC

Sensor response:

[40][03][02][08][B1][43][FF]

[40] = Modbus Slave address

[03] = Modbus function

[02] = Number of bytes

[08][B1] = Content of register 7, decimal equivalent = 2225

[43][FF] = CRC

Temperature = Register 7 x 0.01 = 2225 x 0.01 = 22.25 °C

Register 6 represents the sensors body temperature. The received data needs to be divided by 100 to represent the correct outcome. In this example the result is:  $2225 \times 0.01 = 22.25 \text{ °C}$

Request for serial number, register 40:

Master Request:

[40][03][00][28][00][01][0B][13]

[40] = Modbus slave address

[03] = Modbus function

[00][28] = Start register  
[00][01] = Number of registers  
[0B][13] = CRC

Sensor response:

[40][03][02][0A][29][43][35]

[40] = Modbus Slave address  
[03] = Modbus function  
[02] = Number of bytes  
[0A][29] = Content of register 40, decimal equivalent = 2601  
[43][35] = CRC

Register 40 represents the sensors serial number. In this example the serial number is 2601.

## 7 Making a dependable measurement

### 7.1 The concept of dependability

A measurement with a pyranometer is called “dependable” if it is reliable, i.e. measuring within required uncertainty limits, for most of the time and if problems, once they occur, can be solved quickly.

The requirements for a measurement with a pyranometer may be expressed by the user as:

- required uncertainty of the measurement (see following paragraphs)
- requirements for maintenance and repairs (possibilities for maintenance and repair including effort to be made and processing time)
- a requirement to the expected instrument lifetime (until it is no longer feasible to repair)

It is important to realise that the uncertainty of the measurement is not only determined by the instrument but also by the way it is used.

See also ISO 9060 note 5. In case of pyranometers, the measurement uncertainty as obtained during outdoor measurements is a function of:

- the instrument class
- the calibration procedure / uncertainty
- the duration of instrument employment under natural sunlight (involving the instrument stability specification)
- the measurement conditions (such as tilting, ventilation, shading, instrument temperature)
- maintenance (mainly fouling)
- the environmental conditions\*

Therefore, ISO 9060 says, “statements about the overall measurement uncertainty under outdoor conditions can only be made on an individual basis, taking all these factors into account”.

\* defined at Hukseflux as all factors outside the instrument that are relevant to the measurement such as the cloud cover (presence or absence of direct radiation), sun position, the local horizon (which may be obstructed) or condition of the ground (when tilted). The environmental conditions also involve the question whether or not the measurement at the location of measurement is representative of the quantity that should be measured.

## 7.2 Reliability of the measurement

A measurement is reliable if it measures within required uncertainty limits for most of the time. We distinguish between two causes of unreliability of the measurement:

- related to the reliability of the pyranometer and its design, manufacturing, calibration (hardware reliability).
- related to the reliability of the measurement uncertainty (measurement reliability), which involves hardware reliability as well as condition of use.

Most of the hardware reliability is the responsibility of the instrument manufacturer. The reliability of the measurement however is a joint responsibility of instrument manufacturer and user. As a function of user requirements, taking into account measurement conditions and environmental conditions, the user will select an instrument of a certain class, and define maintenance support procedures.

In many situations there is a limit to a realistically attainable accuracy level. This is due to conditions that are beyond control once the measurement system is in place. Typical limiting conditions are:

- the measurement conditions, for instance when working at extreme temperatures when the instrument temperature is at the extreme limits of the rated temperature range.
- the environmental conditions, for instance when installed at a sub-optimal measurement location with obstacles in the path of the sun.
- other environmental conditions, for instance when assessing PV system performance and the system contains panels at different tilt angles, the pyranometer measurement may not be representative of irradiance received by the entire PV system.

The measurement reliability can be improved by maintenance support. Important aspects are:

- dome fouling by deposition of dust, dew, rain or snow. Fouling results in undefined measurement uncertainty (sensitivity and directional error are no longer defined). This should be solved by regular inspection and cleaning.
- sensor instability. Maximum expected sensor aging is specified per instrument as its non-stability in [% change / year]. In case the sensor is not recalibrated, the uncertainty of the sensitivity gradually will increase. This is solved by regular recalibration.
- moisture condensing under pyranometer domes resulting in a slow change of sensitivity (within specifications). This is solved by regular replacement of desiccant or by maintenance (drying the entire sensor) in case the sensor allows this. For non-serviceable sensors like most second class pyranometers, this may slowly develop into a defect. For first class and secondary standard models (for instance model SR11 first class pyranometer and SR20-D2 digital secondary standard pyranometer) extra desiccant (in a set of 5 bags in an air tight bag) is available.

Another way to improve measurement reliability is to introduce redundant sensors.

- the use of redundant instruments allows remote checks of one instrument using the other as a reference, which leads to a higher measurement reliability.
- in PV system performance monitoring, in addition to instruments measuring in the plane of array, horizontally placed instruments are used for the measurement of global radiation. Global irradiance data enable the user to compare the local climate and system efficiency between different sites. These data can also be compared to measurements by local meteorological stations.

### 7.3 Speed of repair and maintenance

Dependability is not only a matter of reliability but also involves the reaction to problems; if the processing time of service and repairs is short, this contributes to the dependability.

Hukseflux pyranometers are designed to allow easy maintenance and repair. The main maintenance actions are:

- replacement of desiccant
- replacement of cabling

For optimisation of dependability a user should:

- estimate the expected lifetime of the instrument
- design a schedule of regular maintenance
- design a schedule of repair or replacement in case of defects

When operating multiple instruments in a network Hukseflux recommends keeping procedures simple and having a few spare instruments to act as replacements during service, recalibrations and repair.

### 7.4 Uncertainty evaluation

The uncertainty of a measurement under outdoor or indoor conditions depends on many factors, see paragraph 1 of this chapter. It is not possible to give one figure for pyranometer measurement uncertainty. The work on uncertainty evaluation is "in progress". There are several groups around the world participating in standardisation of the method of calculation. The effort aims to work according to the guidelines for uncertainty evaluation (according to the "Guide to Expression of Uncertainty in Measurement" or GUM).



#### 7.4.1 Evaluation of measurement uncertainty under outdoor conditions

Hukseflux actively participates in the discussions about pyranometer measurement uncertainty; we also provide spreadsheets, reflecting the latest state of the art, to assist our users in making their own evaluation. The input to the assessment is summarised:

- 1) The formal evaluation of uncertainty should be performed in accordance with ISO 98-3 Guide to the Expression of Uncertainty in Measurement, GUM.
- 2) The specifications of the instrument according to the list of ISO 9060 classification of pyranometers and pyrhemometers are entered as limiting values of possible errors, to be analysed as type B evaluation of standard uncertainty per paragraph 4.3.7. of GUM. A priori distributions are chosen as rectangular.
- 3) A separate estimate has to be entered to allow for estimated uncertainty due to the instrument maintenance level.
- 4) The calibration uncertainty has to be entered. Please note that Hukseflux calibration uncertainties are lower than those of alternative equipment. These uncertainties are entered in measurement equation (equation is usually Formula 0.1:  $E = U/S$ ), either as an uncertainty in E (zero offsets, directional response) in U (voltage readout errors) or in S (tilt error, temperature dependence, calibration uncertainty).
- 5) In uncertainty analysis for pyranometers, the location and date of interest is entered. The course of the sun is then calculated, and the direct and diffuse components are estimated, based on a model; the angle of incidence of direct radiation is a major factor in the uncertainty.
- 6) In uncertainty analysis for modern pyrhemometers: tilt dependence often is so low that one single typical observation may be sufficient.
- 7) In case of special measurement conditions, typical specification values are chosen. These should for instance account for the measurement conditions (shaded / unshaded, ventilated/ unventilated, horizontal / tilted) and environmental conditions (clear sky / cloudy, working temperature range).
- 8) Among the various sources of uncertainty, some are "correlated"; i.e. present during the entire measurement process, and not cancelling or converging to zero when averaged over time; the off-diagonal elements of the covariance matrix are not zero. Paragraph 5.2 of GUM.
- 9) Among the various sources of uncertainty, some are "uncorrelated"; cancelling or converging to zero when averaged over time; the off-diagonal elements of the covariance matrix are zero. Paragraph 5.1 of GUM.
- 10) Among the various sources of uncertainty, some are "not included in analysis"; this applies for instance to non-linearity for pyranometers, because it is already included in the directional error, and the spectral response for pyranometers and pyrhemometers because it is already taken into account in the calibration process.

**Table 7.4.1.1** Preliminary estimates of achievable uncertainties of measurements with Hukseflux pyranometers. The estimates are based on typical pyranometer properties and calibration uncertainty, for sunny, clear sky days and well maintained stations, without uncertainty loss due to lack of maintenance and due to instrument fouling. The table specifies expanded uncertainties with a coverage factor of 2 and confidence level of 95 %. Estimates are based on 1 s sampling. **IMPORTANT NOTE:** there is no international consensus on uncertainty evaluation of pyranometer measurements, so this table should not be used as a formal reference.

Pyranometer class (ISO 9060)	season	latitude	uncertainty minute totals at solar noon	uncertainty hourly totals at solar noon	uncertainty daily totals
secondary standard (SR20-D2)	summer	mid-latitude	2.7 %	2.0 %	1.9 %
		equator	2.6 %	1.9 %	1.7 %
		pole	7.9 %	5.6 %	4.5 %
	winter	mid-latitude	3.4 %	2.5 %	2.7 %
first class	summer	mid-latitude	4.7 %	3.3 %	3.4 %
		equator	4.4 %	3.1 %	2.9 %
		pole	16.1%	11.4 %	9.2 %
	winter	mid-latitude	6.5 %	4.5 %	5.2 %
second class	summer	mid-latitude	8.4 %	5.9 %	6.2 %
		equator	7.8 %	5.5 %	5.3 %
		pole	29.5 %	21.6 %	18.0 %
	winter	mid-latitude	11.4 %	8.1 %	9.9 %

#### 7.4.2 Calibration uncertainty

New calibration procedures were developed in close cooperation with PMOD World Radiation Center in Davos, Switzerland. The latest calibration method results in an uncertainty of the sensitivity of less than 1.2 %, compared to typical uncertainties of higher than 1.7 % for this pyranometer class. See the appendix for detailed information on calibration hierarchy.

## 8 Maintenance and trouble shooting

### 8.1 Recommended maintenance and quality assurance

SR20-D2 can measure reliably at a low level of maintenance in most locations. Usually unreliable measurements will be detected as unreasonably large or small measured values. As a general rule this means that regular visual inspection combined with a critical review of the measured data, preferably checking against other measurements, is the preferred way to obtain a reliable measurement.

**Table 8.1.1** *Recommended maintenance of SR20-D2. If possible the data analysis and cleaning (1 and 2) should be done on a daily basis. (continued on next page)*

MINIMUM RECOMMENDED PYRANOMETER MAINTENANCE			
	INTERVAL	SUBJECT	ACTION
1	1 week	data analysis	compare measured data to maximum possible / maximum expected irradiance and to other measurements nearby (redundant instruments). Also historical seasonal records can be used as a source for expected values. Analyse night time signals. These signals may be negative (down to - 5 W/m <sup>2</sup> on clear windless nights), due to zero offset a. In case of use with PV systems, compare daytime measurements to PV system output. Look for any patterns and events that deviate from what is normal or expected
2	2 weeks	cleaning	use a soft cloth to clean the dome of the instrument, persistent stains can be treated with soapy water or alcohol
3	6 months	inspection	inspect cable quality, inspect connectors, inspect mounting position, inspect cable, clean instrument, clean cable, inspect levelling, change instrument tilt in case this is out of specification, inspect mounting connection, inspect interior of dome for condensation
4		desiccant replacement	desiccant replacement (if applicable). Change in case the blue colour of the 40 % humidity indicator turns pink (indicating humidity), then replace desiccant. Coat the rubber of the cartridge with silicone grease or vaseline. Desiccant regeneration: heating in an oven at 70 °C for 1 to 2 hours. Humidity indicator regeneration: heating until blue at 70 °C
5	2 years	recalibration	recalibration by side-by-side comparison to a higher standard instrument in the field according to ISO 9847 request "power user" status and a password at the factory permitting to write to registers holding the sensitivity and the calibration history data via the Sensor Manager
6		lifetime assessment	judge if the instrument should be reliable for another 2 years, or if it should be replaced

---

**MINIMUM RECOMMENDED PYRANOMETER MAINTENANCE (continued)**

---

7	6 years	parts replacement	if applicable / necessary replace the parts that are most exposed to weathering; cable, connector, desiccant holder, sun screen. NOTE: use Hukseflux approved parts only.
8		internal inspection	if applicable: open instrument and inspect / replace O-rings; dry internal cavity around the circuit board
9		recalibration	recalibration by side-by-side comparison to a higher standard instrument indoors according to ISO 9847 or outdoors according to ISO9846

---

## 8.2 Trouble shooting

**Table 8.2.1** *Trouble shooting for SR20-D2 (continued on next page)*

General	<p>Inspect the instrument for any damage.</p> <p>Inspect if the humidity indicator is blue. Blue indicates dryness. The colour pink indicates it is humid: in the latter case replace the desiccant (see chapter on maintenance).</p> <p>Inspect if the connector is properly attached.</p> <p>Check the condition of the connectors (on chassis as well as the cable).</p> <p>Inspect if the sensor receives DC voltage power in the range of 5 to 30 VDC.</p> <p>In case 4-20 mA output is used, inspect if the sensor receives DC voltage power in the range of 5 to 30 VDC via the main supply and if the current loop receives DC voltage power in the range of 5.5 to 40 VDC. Do not use the same power supply for these voltages.</p> <p>Inspect the connection of the shield (typically not connected at the network side).</p> <p>Inspect the connection of the sensor power supply, typically the negative is connected to the network <i>common</i>.</p>
Prepare for indoor testing	<p>Install the Sensor Manager software on a PC. Equip the PC with RS-485 communication. Put DC voltage power to the sensor and establish communication with the sensor. At power-up the signal may have a temporary output level different from zero; an offset. Let this offset settle down.</p>
The sensor does not give any signal	<p>Check if the sensor reacts to light: expose the sensor to a strong light source, for instance a 100 W light bulb at 0.1 m distance. The signal should read &gt; 100 W/m<sup>2</sup> now. Darken the sensor either by putting something over it or switching off the light. The instrument voltage output should go down and within one minute approach 0 W/m<sup>2</sup>. Check the data acquisition by replacing the sensor with a spare sensor with the same address.</p>
Not able to communicate with the sensor	<p>Check all physical connections to the sensor and try connecting to the sensor again. If communicating is not possible, try to figure out if the address and communication settings are correct. Analyse the cable performance by measuring resistance from pins to cable ends. The electrical resistance should be &lt; 10 Ω. In case of doubt, try a new cable.</p> <p>Connect sensor to a PC and perform the “Find” and “Find all” operation with the Sensor Manager to locate the sensor and verify the communication settings. If all physical connections are correct, and the sensor still cannot be found, please contact the factory to send the sensor to the manufacturer for diagnosis and service.</p>

---

SR20-D2 does not respond to a request for 6 or more registers	It is not possible to request more than five 16 bit registers in one request. In case of requesting six or more registers in just one request, the sensor will not respond. If requesting six or more registers, use multiple requests: the sensor will respond as expected.
The sensor signal is unrealistically high or low	Note that night-time signals may be negative (down to $-5 \text{ W/m}^2$ on clear windless nights), due to zero offset a. Check if the pyranometer has clean domes. Check the location of the pyranometer; are there any obstructions that could explain the measurement result. Check the orientation / levelling of the pyranometer. Check the cable condition looking for cable breaks. Check the condition of the connectors (on chassis as well as the cable).
The sensor signal shows unexpected variations	Check the presence of strong sources of electromagnetic radiation (radar, radio). Check the condition and connection of the shield. Check the condition of the sensor cable. Check if the cable is not moving during the measurement. Check the condition of the connectors (on chassis as well as the cable)
The outer dome shows internal condensation.	In case there is a minor layer of moisture that is hardly visible: replace the desiccant and wait a few days to see if the situation improves. In case of condensation of droplets: disassemble the instrument and dry out the parts.
The inner dome shows internal condensation	Arrange to send the sensor back to Hukseflux for diagnosis.

### 8.3 Calibration and checks in the field

Recalibration of field pyranometers is typically done by comparison in the field to a reference pyranometer. The applicable standard is ISO 9847 "International Standard-Solar Energy- calibration of field pyranometers by comparison to a reference pyranometer". At Hukseflux an indoor calibration according to the same standard is used.

Hukseflux recommendation for re-calibration:

if possible, perform calibration indoor by comparison to an identical reference instrument, under normal incidence conditions.

The recommended calibration interval of pyranometers is 2 years. The registers containing the applied sensitivity and the calibration history of SR20-D2 are accessible for users. This allows the user to choose his own local calibration service. The same feature may be used for remotely controlled re-calibration of pyranometers in the field. Ask Hukseflux for information on ISO and ASTM standardised procedures for field calibration. Request "power user" status and a password at the factory permitting to write to registers holding the sensitivity and the calibration history data via the Sensor Manager.

In case of field comparison; ISO recommends field calibration to a higher class pyranometer. Hukseflux suggests also allowing use of sensors of the same model and

class, because intercomparisons of similar instruments have the advantage that they suffer from the same offsets. It is therefore just as good to compare to pyranometers of the same brand and type as to compare to an instrument of a higher class. ISO recommends to perform field calibration during several days; 2 to 3 days under cloudless conditions, 10 days under cloudy conditions. In general this is not achievable. In order to shorten the calibration process Hukseflux suggests to allow calibration at normal incidence, using hourly totals near solar noon.

Hukseflux main recommendations for field intercomparisons are:

- 1) to take normal incidence as a reference and not the entire day.
- 2) to take a reference of the same brand and type as the field pyranometer or a pyranometer of a higher class, and
- 3) to connect both to the same electronics, so that electronics errors (also offsets) are eliminated.
- 4) to mount all instruments on the same platform, so that they have the same body temperature.
- 5) assuming that the electronics are independently calibrated, to analyse radiation values at normal incidence radiation (possibly tilting the radiometers to approximately normal incidence), if this is not possible to compare 1 hour totals around solar noon for horizontally mounted instruments.
- 6) for second class radiometers, to correct deviations of more than  $\pm 10\%$ . Lower deviations should be interpreted as acceptable and should not lead to a revised sensitivity.
- 7) for first class pyranometers, to correct deviations of more than  $\pm 5\%$ . Lower deviations should be interpreted as acceptable and should not lead to a revised sensitivity.
- 8) for secondary standard instruments, to correct deviations of more than  $\pm 3\%$ . Lower deviations should be interpreted as acceptable and should not lead to a revised sensitivity.

## 8.4 Data quality assurance

Quality assurance can be done by:

- analysing trends in solar irradiance signal
- plotting the measured irradiance against mathematically generated expected values
- comparing irradiance measurements between sites
- analysis of night time signals

The main idea is that one should look out for any unrealistic values. There are programs on the market that can semi-automatically perform data screening. See for more information on such a program: [www.dqms.com](http://www.dqms.com).



## 9 Appendices

### 9.1 Appendix on cable extension / replacement

The sensor cable of SR20-D2 is equipped with a M16 straight connector. In case of cable replacement, it is recommended to purchase a new cable with connector at Hukseflux. An alternative is to choose for a Do-it-yourself (DIY) approach; please ask for the DIY connector assembly guide. In case of cable extension, the user may choose purchasing a new cable with connector at Hukseflux or extending the existing cable by himself. Please note that Hukseflux does not provide support for DIY connector- and cable assembly.

SR20-D2 is equipped with one cable. Maximum length of the sensor cable depends on the RS-485 network topology applied in the field. In practice, daisy chain topologies or point to point (PtP) topologies are used. The length of the sensor cable should be as short as possible to avoid signal reflections on the line.

When the sensor is used in a traditional daisy chain bus topology, the sensor cable length is the distance covered from the sensor to the cable trunk of the main data line. This line is often called the stub. Stub length (and thus cable length) has to be shorter than one-tenth of the sensor driver's output rise time and a factor for signal velocity in the sensor cable. For SR20-D2 in daisy chain configurations, maximum cable length is around 12 metres.

In point to point configurations cable lengths can in theory be much longer; RS-485 is specified for cable lengths up to 1200 metres.

Connector, cable and cable connection specifications are summarised on the next page.



**Table 9.1.1 Preferred specifications for SR20-D2 cable replacement and extension**

General replacement	please order a new cable with connector at Hukseflux or choose for a DIY approach. In case of DIY replacement by the user see connector specifications below and ask for the DIY connector assembly guide
General cable extension	please order a new cable with connector at Hukseflux or solder the new cable conductors and shield to the original sensor cable and make a connection, using adhesive-lined heat shrink tubing, with specifications for outdoor use. Always connect shield
Connectors used	chassis: M16 panel connector, male thread, 10-pole, HUMMEL AG 7.840.200.000 panel connector, front mounting, short version. cable: M16 straight connector, female thread, 10-pole. HUMMEL AG 7.810.300.00M straight connector, female thread, for cable 3 to 6 x 10 <sup>-3</sup> m, special version. The shield is electrically connected to the connector.
Cable	8-wire, shielded, with copper conductors (at Hukseflux 8-wire shielded cable is used, of which 2 wires are used for signal transmission and 2 for power supply)
Conductor resistance	< 0.1 Ω/m
Length	Cables should be kept as short as possible. In daisy chain topologies, cable length to main data line should be less than 12 metres. In point to point topologies cable length should not exceed RS-485 specifications of maximum 1200 metres.
Outer sheath	with specifications for outdoor use (for good stability in outdoor applications)

## 9.2 Appendix on tools for SR20-D2

**Table 9.2.1 Specifications of tools for SR20-D2**

tooling required for sun screen fixation and removal	by hand
tooling required for bottom plate fixation and removal	hex key 2.5 mm
tooling required for desiccant holder fixation and removal	spanner size 20 mm
tooling required for wire fixation and removal (internal wiring inside SR20-D2 body)	screwdriver blade width 2 mm

### 9.3 Appendix on spare parts for SR20-D2

- Desiccant holder (with glass window and rubber ring)
- Desiccant (set of 5 bags in air tight bag)
- Humidity indicator
- Levelling feet (set of 2)
- Static foot
- Sun screen with metal ring and thumb screw
- SR20-D2 cable with connector (specify length in multiples of 5 m)
- O-ring SR20-D2

NOTE: Outer dome, level and sensor of SR20-D2 cannot be supplied as spare parts. In case of possible damage to the SR20-D2, after repair the instrument must be tested to verify performance within specification limits. This is required by ISO 9060. Testing involves verification of the directional response after dome, thermal sensor and level replacement and verification of the temperature response after thermal sensor replacement.

## 9.4 Appendix on standards for classification and calibration

Both ISO and ASTM have standards on instrument classification and methods of calibration. The World Meteorological Organisation (WMO) has largely adopted the ISO classification system.

**Table 9.4.1** *Pyranometer standardisation in ISO and ASTM.*

STANDARDS ON INSTRUMENT CLASSIFICATION AND CALIBRATION	
ISO STANDARD	EQUIVALENT ASTM STANDARD
ISO 9060:1990 Solar energy -- Specification and classification of instruments for measuring hemispherical solar and direct solar radiation	not available Comment: work is in progress on a new ASTM equivalent standard
Comment: a standard "Solar energy --Methods for testing pyranometer and pyrhelimeter characteristics" has been announced in ISO 9060 but is not yet implemented.	not available
ISO 9846:1993 Solar energy -- Calibration of a pyranometer using a pyrhelimeter	ASTM G167 - 05 Standard Test Method for Calibration of a Pyranometer Using a Pyrhelimeter
ISO 9847:1992 Solar energy -- Calibration of field pyranometers by comparison to a reference pyranometer	ASTM E 824 -10 Standard Test Method for Transfer of Calibration from Reference to Field Radiometers  ASTM G207 - 11 Standard Test Method for Indoor Transfer of Calibration from Reference to Field Pyranometers
ISO 9059:1990 Solar energy -- Calibration of field pyrhelimeters by comparison to a reference pyrhelimeter	ASTM E 816 Standard Test Method for Calibration of Pyrhelimeters by Comparison to Reference Pyrhelimeters

## 9.5 Appendix on calibration hierarchy

The World Radiometric Reference (WRR) is the measurement standard representing the SI unit of irradiance. Use of WRR is mandatory when working according to the standards of both WMO and ISO. ISO9874 states under paragraph 1.3: the methods of calibration specified are traceable to the WRR. The WMO manual states under paragraph 7.1.2.2: the WRR is accepted as representing the physical units of total irradiance.

The worldwide homogeneity of the meteorological radiation measurements is guaranteed by the World Radiation Center in Davos Switzerland, by maintaining the World Standard Group (WSG) which materialises the World Radiometric Reference.

See [www.pmodwrc.ch](http://www.pmodwrc.ch)

The Hukseflux standard is traceable to an outdoor WRR calibration. Some small corrections are made to transfer this calibration to the Hukseflux standard conditions: sun at zenith and 1000 W/m<sup>2</sup> irradiance level. During the outdoor calibration the sun is typically at 20 to 40° zenith angle, and the total irradiance at a 700 W/m<sup>2</sup> level.

**Table 9.5.1** Calibration hierarchy for pyranometers

---

### WORKING STANDARD CALIBRATION AT PMOD / WRC DAVOS

---

Calibration of working standard pyranometers:

Method: ISO 9846, type 1 outdoor. This working standard has an uncertainty "uncertainty of standard". The working standard has been calibrated under certain "test conditions of the standard". The working standard has traceability to WRR world radiometric reference.

---

### CORRECTION OF (WORKING) STANDARD CALIBRATION TO STANDARDISED REFERENCE CONDITIONS

---

Correction from "test conditions of the standard" to "reference conditions" i.e. to normal incidence and 20 °C:

Using known (working) standard pyranometer properties: directional, non linearity, offsets, temperature dependence). This correction has an uncertainty; "uncertainty of correction".

At Hukseflux we also call the working standard pyranometer "standard".

---

### INDOOR PRODUCT CALIBRATION

---

Calibration of products, i.e. pyranometers:

Method: according to ISO 9847, Type IIc, which is an indoor calibration.

This calibration has an uncertainty associated with the method.

(In some cases like the BSRN network the product calibration is with a different method; for example again type 1 outdoor)

---

### CALIBRATION UNCERTAINTY CALCULATION

---

ISO 98-3 Guide to the Expression of Uncertainty in Measurement, GUM Determination of combined expanded uncertainty of calibration of the product, including uncertainty of the working standard, uncertainty of correction, uncertainty of the method (transfer error). The coverage factor must be determined; at Hukseflux we work with a coverage factor  $k = 2$ .

---

## 9.6 Appendix on meteorological radiation quantities

A pyranometer measures irradiance. The time integrated total is called radiant exposure. In solar energy radiant exposure is often given in  $W \cdot h/m^2$ .

**Table 9.6.1** Meteorological radiation quantities as recommended by WMO (additional symbols by Hukseflux Thermal Sensor). POA stands for Plane of Array irradiance. The term originates from ASTM and IEC standards.

SYMBOL	DESCRIPTION	CALCULATION	UNITS	ALTERNATIVE EXPRESSION	
$E_{\downarrow}$	downward irradiance	$E_{\downarrow} = E_{g\downarrow} + E_{l\downarrow}$	$W/m^2$		
$H_{\downarrow}$	downward radiant exposure for a specified time interval	$H_{\downarrow} = H_{g\downarrow} + H_{l\downarrow}$	$J/m^2$		
$E_{\uparrow}$	upward irradiance	$E_{\uparrow} = E_{g\uparrow} + E_{l\uparrow}$	$W/m^2$		
$H_{\uparrow}$	upward radiant exposure for a specified time interval	$H_{\uparrow} = H_{g\uparrow} + H_{l\uparrow}$	$J/m^2$	$W \cdot h/m^2$	Change of units
$E$	direct solar irradiance normal to the apparent solar zenith angle		$W/m^2$	DNI	Direct Normal Irradiance
$E_0$	solar constant		$W/m^2$		
$E_{g\downarrow h}$	global irradiance; hemispherical irradiance on a specified, in this case horizontal surface.*	$E_{g\downarrow} = E \cos \theta_h + E_{d\downarrow}$	$W/m^2$	GHI	Global Horizontal Irradiance
$E_{g\downarrow t}$	global irradiance; hemispherical irradiance on a specified, in this case tilted surface.*	$E_{g\downarrow} = E \cdot \cos \theta_t + E_{d\downarrow t} + E_{r\uparrow t}$ ***	$W/m^2$	POA	Plane of Array
$E_{d\downarrow}$	downward diffuse solar radiation		$W/m^2$	DHI	Diffuse Horizontal Irradiance
$E_{l\uparrow}, E_{l\downarrow}$	upward / downward long-wave irradiance		$W/m^2$		
$E_{r\uparrow}$	reflected solar irradiance		$W/m^2$		
$E^*$	net irradiance	$E^* = E_{\downarrow} - E_{\uparrow}$	$W/m^2$		
$T_{\downarrow}$	apparent surface temperature**		$^{\circ}C$ or $K$		
$T_{\uparrow}$	apparent sky temperature**		$^{\circ}C$ or $K$		
SD	sunshine duration		h		

$\theta$  is the apparent solar zenith angle  $\theta_h$  relative to horizontal,  $\theta_t$  relative to a tilted surface  
 $g$  = global,  $l$  = long wave,  $t$  = tilted \*,  $h$  = horizontal\*

\* distinction horizontal and tilted from Hukseflux,

\*\*  $T$  symbols introduced by Hukseflux,

\*\*\* contributions of  $E_{d\downarrow t}$  and  $E_{r\uparrow t}$  are  $E_{d\downarrow}$  and  $E_{r\uparrow}$  both corrected for the tilt angle of the surface

## 9.7 Appendix on ISO and WMO classification tables

**Table 9.7.1** Classification table for pyranometers per ISO 9060 and WMO.

*NOTE: WMO specification of spectral selectivity is different from that of ISO. Hukseflux conforms to the ISO limits. WMO also specifies expected accuracies. ISO finds this not to be a part of the classification system because it also involves calibration. Please note that WMO achievable accuracies are for clear days at mid latitudes and that the uncertainty estimate does not include uncertainty due to calibration\*.*

<b>ISO CLASSIFICATION** TABLE</b>			
ISO CLASS	SECONDARY STANDARD	FIRST CLASS	SECOND CLASS
Specification limit			
Response time (95 %)	15 s	30 s	60 s
Zero offset a (response to 200 W/m <sup>2</sup> net thermal radiation)	+ 7 W/m <sup>2</sup>	+ 15 W/m <sup>2</sup>	+ 30 W/m <sup>2</sup>
Zero offset b (response to 5 K/h in ambient temperature)	± 2 W/m <sup>2</sup>	± 4 W/m <sup>2</sup>	± 8 W/m <sup>2</sup>
Non-stability (change per year)	± 0.8 %	± 1.5 %	± 3 %
Non-linearity (100 to 1000 W/m <sup>2</sup> )	± 0.5 %	± 1 %	± 3 %
Directional response	± 10 W/m <sup>2</sup>	± 20 W/m <sup>2</sup>	± 30 W/m <sup>2</sup>
Spectral selectivity (350 to 1 500 x 10 <sup>-9</sup> m) (WMO 300 to 3 000 x 10 <sup>-9</sup> m)	± 3 %	± 5 %	± 10 %
Temperature response (interval of 50 K)**	2 %	4 %	8 %
Tilt response (0 to 90 ° at 1000 W/m <sup>2</sup> )	± 0.5 %	± 2 %	± 5 %
<b>ADDITIONAL WMO SPECIFICATIONS</b>			
WMO CLASS	HIGH QUALITY	GOOD QUALITY	MODERATE QUALITY
WMO: achievable accuracy for daily sums*	2 %	5 %	10 %
WMO: achievable accuracy for hourly sums*	3 %	8 %	20 %
WMO: achievable accuracy for minute sums*	not specified	not specified	not specified
WMO: resolution (smallest detectable change)	1 W/m <sup>2</sup>	5 W/m <sup>2</sup>	10 W/m <sup>2</sup>
<b>CONFORMITY TESTING***</b>			
ISO 9060	individual instrument only: all specs must comply	group compliance	group compliance

\* WMO 7.2.1: The estimated uncertainties are based on the following assumptions: (a) instruments are well-maintained, correctly aligned and clean; (b) 1 min and 1 h figures are for clear-sky irradiances at solar noon; (c) daily exposure values are for clear days at mid-latitudes. WMO 7.3.2.5: Table 7.5 lists the expected maximum deviation from the true value, excluding calibration errors.

\*\* At Hukseflux the expression ± 1 % is used instead of a range of 2 %.

\*\*\* an instrument is subject to conformity testing of its specifications. Depending on the classification, conformity compliance can be proven either by group- or individual compliance. A specification is fulfilled if the mean value of the respective test result does not exceed the corresponding limiting value of the specification for the specific category of instrument.

## 9.8 Appendix on definition of pyranometer specifications

**Table 9.8.1** *Definition of pyranometer specifications*

SPECIFICATION	DEFINITION	SOURCE
Response time (95 %)	time for 95 % response. The time interval between the instant when a stimulus is subjected to a specified abrupt change and the instant when the response reaches and remains within specified limits around its final steady value. The response time is a measure of the thermal inertia inherent in the stabilization period for a final reading.	ISO 9060-1990 WMO 1.6.3
Zero offset a: (200 W/m <sup>2</sup> net thermal radiation )	response to 200 W/m <sup>2</sup> net thermal radiation (ventilated). Hukseflux assumes that unventilated instruments have to specify the zero-offset in unventilated – worst case – conditions. Zero offsets are a measure of the stability of the zero-point. Zero offset a is visible at night as a negative offset, the instrument dome irradiates in the far infra red to the relatively cold sky. This causes the dome to cool down. The pyranometer sensor irradiates to the relatively cool dome, causing a negative offset. Zero offset a is also assumed to be present during daytime.	ISO 9060-1990
Zero offset b: (5 K/h in ambient temperature)	response to 5 K/h change in ambient temperature. Zero offsets are a measure of the stability of the zero-point.	ISO 9060-1990
Non-stability (change per year)	percentage change in sensitivity per year. The dependence of sensitivity resulting from ageing effects which is a measure of the long-term stability.	ISO 9060-1990
Non-linearity (100 to 1000 W/m <sup>2</sup> )	percentage deviation from the sensitivity at 500 W/m <sup>2</sup> due to the change in irradiance within the range of 100 W/m <sup>2</sup> to 1000 W/m <sup>2</sup> . Non-linearity has an overlap with directional response, and therefore should be handled with care in uncertainty evaluation.	ISO 9060-1990
Directional response	the range of errors caused by assuming that the normal incidence sensitivity is valid for all directions when measuring from any direction a beam radiation whose normal incidence irradiance is 1000 W/m <sup>2</sup> . Directional response is a measure of the deviations from the ideal “cosine behaviour” and its azimuthal variation.	ISO 9060-1990
Spectral selectivity (350 to 1500 x 10 <sup>-9</sup> m) (WMO 300 to 3000 x 10 <sup>-9</sup> m)	percentage deviation of the product of spectral absorptance and spectral transmittance from the corresponding mean within 350 x 10 <sup>-9</sup> m to 1500 x 10 <sup>-9</sup> m and the spectral distribution of irradiance. Spectral selectivity is a measure of the spectral selectivity of the sensitivity.	ISO 9060-1990
Temperature response (interval of 50 K)	percentage deviation of the sensitivity due to change in ambient temperature within an interval of 50 K the temperature of the pyranometer body.	ISO 9060-1990
Tilt response (0° to 90° at 1000 W/m <sup>2</sup> )	percentage deviation from the sensitivity at 0° tilt (horizontal) due to change in tilt from 0° to 90° at 1000 W/m <sup>2</sup> irradiance. Tilt response describes changes of the sensitivity due to changes of the tilt angle of the receiving surface.	ISO 9060-1990
Sensitivity	the change in the response of a measuring instrument divided by the corresponding change in the stimulus.	WMO 1.6.3
Spectral range	the spectral range of radiation to which the instrument is sensitive. For a normal pyranometer this should be in the 0.3 to 3 x 10 <sup>-6</sup> m range. Some pyranometers with coloured glass domes have a limited spectral range.	Hukseflux

## 9.9 Appendix on terminology / glossary

**Table 9.9.1** *Definitions and references of used terms*

TERM	DEFINITION (REFERENCE)
Solar energy or solar radiation	solar energy is the electromagnetic energy emitted by the sun. Solar energy is also called solar radiation and shortwave radiation. The solar radiation incident on the top of the terrestrial atmosphere is called extra-terrestrial solar radiation; 97 % of which is confined to the spectral range of 290 to $3\,000 \times 10^{-9}$ m. Part of the extra-terrestrial solar radiation penetrates the atmosphere and directly reaches the earth's surface, while part of it is scattered and / or absorbed by the gas molecules, aerosol particles, cloud droplets and cloud crystals in the atmosphere. The former is the direct component, the latter is the diffuse component of the solar radiation. (ref: WMO, Hukseflux)
Hemispherical solar radiation	solar radiation received by a plane surface from a $180^\circ$ field of view angle (solid angle of $2\pi$ sr). (ref: ISO 9060)
Global solar radiation	the solar radiation received from a $180^\circ$ field of view angle on a horizontal surface is referred to as global radiation. Also called GHI. This includes radiation received directly from the solid angle of the sun's disc, as well as diffuse sky radiation that has been scattered in traversing the atmosphere. (ref: WMO) Hemispherical solar radiation received by a horizontal plane surface. (ref: ISO 9060)
Plane-of-array irradiance	also POA: hemispherical solar irradiance in the plane of a PV array. (ref: ASTM E2848-11 / IEC 61724)
Direct solar radiation	radiation received from a small solid angle centred on the sun's disc, on a given plane. (ref: ISO 9060)
Terrestrial or Longwave radiation	radiation not of solar origin but of terrestrial and atmospheric origin and having longer wavelengths ( $3\,000$ to $100\,000 \times 10^{-9}$ m). In case of downwelling $E_i \downarrow$ also the background radiation from the universe is involved, passing through the "atmospheric window". In case of upwelling $E_i \uparrow$ , composed of long-wave electromagnetic energy emitted by the earth's surface and by the gases, aerosols and clouds of the atmosphere; it is also partly absorbed within the atmosphere. For a temperature of 300 K, 99.99 % of the power of the terrestrial radiation has a wavelength longer than $3\,000 \times 10^{-9}$ m and about 99 per cent longer than $5\,000 \times 10^{-9}$ m. For lower temperatures, the spectrum shifts to longer wavelengths. (ref: WMO)
World Radiometric Reference (WRR)	measurement standard representing the SI unit of irradiance with an uncertainty of less than $\pm 0.3$ % (see the WMO Guide to Meteorological Instruments and Methods of Observation, 1983, subclause 9.1.3). The reference was adopted by the World Meteorological Organization (WMO) and has been in effect since 1 July 1980. (ref: ISO 9060)
Albedo	ratio of reflected and incoming solar radiation. Dimensionless number that varies between 0 and 1. Typical albedo values are: $< 0.1$ for water, from 0.1 for wet soils to 0.5 for dry sand, from 0.1 to 0.4 for vegetation, up to 0.9 for fresh snow.
Angle of incidence	angle of radiation relative to the sensor measured from normal incidence (varies from $0^\circ$ to $90^\circ$ ).
Zenith angle	angle of incidence of radiation, relative to zenith. Equals angle of incidence for horizontally mounted instruments
Azimuth angle	angle of incidence of radiation, projected in the plane of the sensor surface. Varies from $0^\circ$ to $360^\circ$ . 0 is by definition the cable exit direction, also called north, east is $+90^\circ$ . (ASTM G113-09)
Sunshine duration	sunshine duration during a given period is defined as the sum of that sub-period for which the direct solar irradiance exceeds $120 \text{ W/m}^2$ . (ref: WMO)



## 9.10 Appendix on floating point format conversion

For efficient use of microcontroller capacity some registers in the SR20-D2 contain data in a *float or floating point* format. In fact, a floating point is an approximation of a real number represented by a number of significant digits (*mantissa*) and an exponent. For implementation of the floating point numbers, Hukseflux follows the IEEE 754 standard. In this example the floating point of register 41 and 42 is converted to the decimal value it represents. In the Sensor Manager software and other Modbus tools, floating point data will be converted to decimal data automatically.

Example of the calculation of register 41 + 42 representing a floating point for the sensitivity of the sensor, which is 15.14:

Data in register 41, 16754 (MSW)

Data in register 42, 15729 (LSW)

Double word:

$$(MSW \times 2^{16}) + LSW \qquad \text{so: } (16754 \times 2^{16}) + 15729 = 1098005873$$

According to IEEE 754:

Sign bit:

$$1098005873 < 2147483647 \qquad \text{so: sign bit} = 1;$$

The number 2147483647 is defined by IEEE 754

Exponent:

$$1098005873 / 2^{23} = 130 \text{ (digits after the decimal point are ignored)}$$

$$130 - 127 = 3 \qquad \text{so: exponent} = 3;$$

The number 127 is a constant defined by IEEE 754

Mantissa:

$$130 \times 2^{23} = 1090519040$$

$$1098005873 - 1090519040 = 7486833$$

$$7486833 / 2^{23} = 0.8925$$

According to IEEE 754, 1 has to be added to get mantissa

$$0.8925 + 1 = 1.8925 \qquad \text{so: mantissa} = 1.8925$$

Calculation of floating point:

$$\text{float} = \text{sign bit} \times \text{mantissa} \times (2^{\text{exponent}}) = 1 \times 1.8925 \times 2^3 = 15.14$$

$$\text{so: floating point} = 15.14$$

## 9.11 Appendix on function codes, register and coil overview

Table 9.11.1 Supported Modbus function codes

SUPPORTED MODBUS FUNCTION CODES	
FUNCTION CODE (HEX)	DESCRIPTION
0x01	Read Coils
0x02	Read Discrete Inputs
0x03	Read Holding Registers
0x04	Read Input Register
0x05	Write Single Coil
0x06	Write Single Holding Register
0x0F	Write Multiple Coils
0x10	Write Multiple Registers



Your data request may need an offset of +1 for each SR20-D2 register number, depending on processing by the network master. Example: SR20-D2 register number 7 + master offset = 7 + 1 = master register number 8. Consult the manual of the device acting as the local master.

Table 9.11.2 Modbus registers 0 to 99

MODBUS REGISTERS 0-99				
REGISTER NUMBER	PARAMETER	DESCRIPTION OF CONTENT	TYPE OF	FORMAT OF DATA
0	Modbus address	Sensor address in Modbus network, default = 1	R/W	U16
1	Serial communication settings	Sets the serial communication, default = 5	R/W	U16
2 + 3	Irradiance (temperature compensated signal)	Temperature compensated signal in $\times 0.01 \text{ W/m}^2$	R	S32
4 + 5	Irradiance (uncompensated signal)	Uncompensated signal in $\times 0.01 \text{ W/m}^2$	R	S32
6	Sensor body temperature	In $\times 0.01 \text{ }^\circ\text{C}$	R	S16
7	Sensor electrical resistance	In $\times 0.1 \text{ } \Omega$	R	U16
8	Scaling factor irradiance	Default = 100	R	U16
9	Scaling factor temperature	Default = 100	R	U16
10 + 11	Sensor voltage output	In $\times 10^{-9} \text{ V}$	R	S32
12 to 31	Factory use only			
32 to 35	Sensor model	Part one of sensor description	R	String
36 to 39	Sensor model	Part two of sensor description	R	String

MODBUS REGISTERS 0 – 99, continued				
REGISTER NUMBER	PARAMETER	DESCRIPTION OF CONTENT	TYPE OF	FORMAT OF DATA
32 to 35	Sensor model	Part one of sensor description	R	String
36 to 39	Sensor model	Part two of sensor description	R	String
40	Sensor serial number		R	U16
41 + 42	Sensor sensitivity	$\ln \times 10^{-6} \text{ V}/(\text{W}/\text{m}^2)$	R	Float
43	Response time	$\ln \times 0.1 \text{ s}$	R	U16
44	Sensor resistance	$\ln \times 0.1 \Omega$	R	U16
45	Reserved	Always 0	R	U16
46 + 47	Sensor calibration date	Calibration date of the sensor in YYYYMMDD	R	U32
48 to 60	Factory use			
61	Firmware version		R	U16
62	Hardware version		R	U16
63 + 64	Sensor sensitivity history 1	$\ln \times 10^{-6} \text{ V}/(\text{W}/\text{m}^2)$ Default value is 0	R	Float
65 + 66	Calibration date history 1	Former calibration date of the sensor in YYYYMMDD Default value is 0	R	U32
67 + 68	Sensor sensitivity history 2	See register 63 + 64	R	Float
69 + 70	Calibration date history 2	See register 65 + 66	R	U32
71 + 72	Sensor sensitivity history 3	See register 63 + 64	R	Float
73 + 74	Calibration date history 3	See register 65 + 66	R	U32
75 + 76	Sensor sensitivity history 4	See register 63 + 64	R	Float
77 + 78	Calibration date history 4	See register 65 + 66	R	U32
79 + 80	Sensor sensitivity history 5	See register 63 + 64	R	Float
81 + 82	Calibration date history 5	See register 65 + 66	R	U32
83 + 84	Directional response measurement date	Directional response measurement date in YYYYMMDD	R	U32
85	Directional response measurement employee		R	U16
86	Temperature response	$\ln \times 0.01 \%$	R	S16
87 + 88	Polynomial temperature coefficient a		R	Float
89 + 90	Polynomial temperature coefficient b		R	Float
91 + 92	Polynomial temperature coefficient c		R	Float

MODBUS REGISTERS 0 – 99, continued				
REGISTER NUMBER	PARAMETER	DESCRIPTION OF CONTENT	TYPE OF	FORMAT OF DATA
93 + 94	Temperature response characterisation measurement date	Temperature response characterisation measurement date of the sensor in YYYYMMDD.	R	U32
95	Temperature response characterisation measurement employee		R	U16
96 + 97	Factory use only			
98	Humidity	In x 0.01 %	R	U16
99	Humidity temperature	In x 0.01 °C	R	S16

Note 1: Up to five 16 bit registers can be requested in one request. If requesting six or more registers, use multiple requests.



Please note that if your data request needs an offset of +1 for each SR20-D2 register number, depending on processing by the network master, this offset applies to coils as well. Consult the manual of the device acting as the local master.

**Table 9.11.3** Coils

COILS				
COIL	PARAMETER	DESCRIPTION	TYPE OF	OBJECT TYPE
0	Restart	Restart the sensor	W	Single bit
1	Reserved			
2	Check	Measure sensor electrical resistance	W	Single bit

## 9.12 EC declaration of conformity



We, Hukseflux Thermal Sensors B.V.  
Delftechpark 31  
2628 XJ Delft  
The Netherlands

in accordance with the requirements of the following directive:

2004/108/EC The Electromagnetic Compatibility Directive

hereby declare under our sole responsibility that:

Product model: SR20-D2  
Type: Pyranometer

has been designed to comply and is in conformity with the relevant sections and applicable requirements of the following standards:

Emission: EN 61326-1: 2013  
Immunity: EN 61326-1: 2013

A handwritten signature in blue ink, appearing to be 'Eric Hoeksema', written over a faint grid background.

Eric HOEKSEMA  
Director  
Delft  
June 07, 2015



