



EGW200 User Manual



Copyright

Copyright© 2015 Elastix. All rights reserved. No part of this document may be reproduced without prior written permission.

Confidentiality

Information contained herein is of a highly sensitive nature and is confidential and proprietary to Elastix. No part may be distributed, reproduced or disclosed orally or in written form to any party other than the direct recipients without the express written consent of Elastix.

Disclaimer

Elastix reserves the right to modify the design, characteristics, and products at any time without notification or obligation and shall not be held liable for any error or damage of any kind resulting from the use of this document.

Elastix has made every effort to ensure that the information contained in this document is accurate and complete; however, the contents of this document are subject to revision without notice. Please contact Elastix to ensure you have the latest version of this document.

Trademarks

All other trademarks mentioned in this document are the property of their respective owners.

Table of Contents

1. Overview	1
What is EGW200?	1
Sample Application	2
Product Appearance	2
Main Features	4
Physical Information	5
Software	5
2. System	6
Status	6
Time	8
Login Settings	9
General and Cluster	10
Language Settings	10
Scheduled Reboot	11
Working Mode	11
Tools and Information	13
Reboot Tools	13
Information	14
3. GSM	16
GSM Settings	16
IMEI Modification	17
Call Duration Limit Settings	20
Call Forwarding	23
DTMF	24
Toolkit	25

4. SIP and Routing	26
SIP Endpoints	26
Main Endpoint Settings	26
Advanced: Registration Options	29
Call Settings	30
Advanced: Signaling Settings	30
Advanced: Timer Settings	31
Advanced SIP Settings	32
Networking	32
Advanced: NAT Settings	33
Parsing and Compatibility	34
Security	35
Media	36
Codec Settings	36
5. Routing.....	37
Call Routing Rule	37
Groups	40
MNP Settings	41
6. SMS	42
SMS Settings	42
General	42
Sender Options	42
SMS to E-mail	42
SMS Control	44
SMS Sender	46
SMS Inbox	46
SMS Outbox	47
7. Network	47
LAN Settings	47
DDNS Settings	50
Toolkit	50
8. Advanced	51
Asterisk API	51
Asterisk CLI	53

Asterisk File Editor	54
9. Logs	54
Appendix Feature List	59
Application diagrams	62

1. Overview

What is EGW200?

The Elastix EGW200 is an open source asterisk-based GSM VoIP Gateway solution for SMBs and SOHOs. With friendly GUI and unique modular design, users may easily setup their customized Gateway. Also secondary development can be completed through AMI (Asterisk Management Interface).

The Modular Design GSM Gateway supports up to 8 GSM channels, developed for interconnecting the GSM cellular networks with a wide selection of codecs and signaling protocol, including G.711A, G.711U, G.729, G.722, G.723, G.726 and GSM to quickly reduce communication expenses and maximize cost-savings. It supports hot-swap for both SIM cards and GSM gateway modules. Users can simply add or remove the modules for hardware expansion or exchange.

If you connect to ETH1, you can access Board 1 only and access other boards with different port numbers which can avoid IP conflict. Otherwise if you connect to ETH2, you can access different Boards with different IP addresses.

Our products support SMS messages sending, receiving, group sending and SMS to E-mail.

Sample Application

Figure 1-2-1 Topological Graph

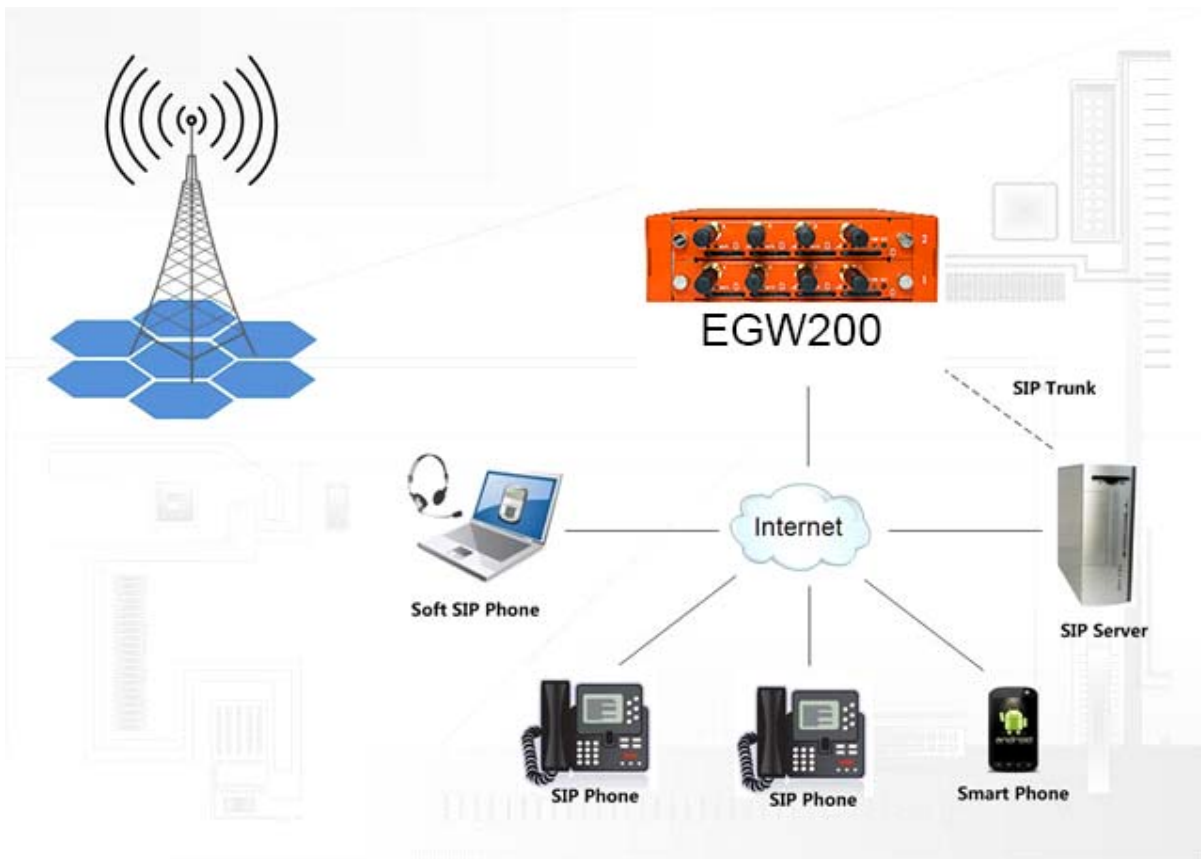

Product Appearance

The picture below is appearance of EGW200.

Figure 1-3-1 Product Appearance



Figure 1-3-2 Front Panel

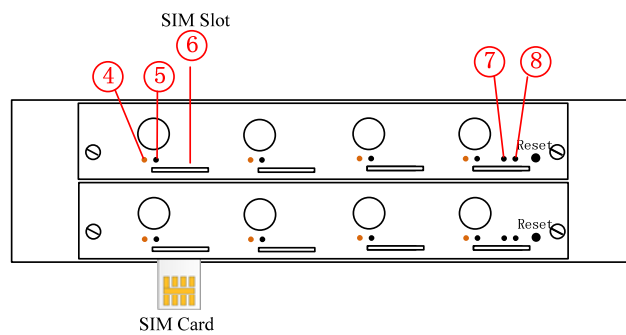
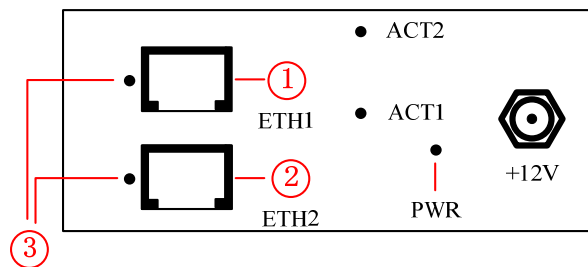

Figure 1-3-3 Back Panel



①~②Network Data Switch Board: ETH1, ETH2.

ETH1: Access Board 1 only, provide proxy access to other boards with different port numbers which can avoid IP conflict.

ETH2: Access different Boards with different IP address.

Table 1-3-1 LED Indicator

LED Indicator	Color	Status
③ Network Status LED	Green and Flash	Network Connected
④ Signal Status LED	Green and Flash	Module Initiating
	Red and Flash	No SIM Card
	Red and No-flash	Worst Signal Quality
	Yellow and No-flash	Medium Signal Quality
	Green and No-flash	Best Signal Quality

⑤ Call Status LED	Flash (0.25s)	Communicating
	Blind	Normal
⑦ Running Status LED	Green and Flash(0.5s)	Work Normally
⑧ Power Indicator	Always Green	Supply Power
During reset, all LED indicators flash.		

The EGW200 provides 2 working modes: Stand-alone and Cluster.

- Stand-alone: A single IP address manages one GSM modules (4 ports).

Table 1-3-2 ETH2 IP Addresses

Stack Num	IP	Username	Password
①	172.16.99.1	admin	admin
②	172.16.99.2	admin	admin

- Cluster: A single IP address manages up to 2 GSM modules (up to 8 ports).

Default IP: 172.16.99.1

Main Features

- Modular design
- Based on Asterisk®
- Editable Asterisk® configuration file
- Wide selection of codecs and signaling protocol
- Support SMS sending, receiving, group sending
- Support transferring SMS to E-mail
- Support SMS automatically resent
- Support SMS remotely controlling gateway
- Support USSD service
- Support IMEI modification
- Support PIN identification

- Support unlimited routing rules and flexible routing settings
- SIM cards and modules are all hot-swap
- Stable performance, flexible dialing, friendly GUI

Physical Information

Table 1-5-1 Description of Physical Information

Weight	1300g
Size	15cm*19cm*4.5cm
Frequency	GSM 850/900/1800/1900MHz
Temperature	-20~70°C (Storage)
	0~40°C (Operation)
Operation humidity	10%~90% non-condensing
Power source	12V DC/4A
Max power	10W
LAN port	2

Software

Default IP: 172.16.99.1

Username: admin

Password: admin

Every module is independent with each other, please enter the default IP in your browser to scan and configure the module you want. For the first time, please enter every IP to configure every module one by one. Now we offer you two ways to access to your gateway. There are two RJ45 Network ports on the board, ETH1 and ETH2. They are different. If choose ETH1, you can access Board 1 only, then access to other boards with different port numbers but the same IP address, this will help to avoid IP conflict. If you choose ETH2, you can access different Boards with different IP addresses.

Notice: Log in

Figure 1-6-1 LOG IN Interface

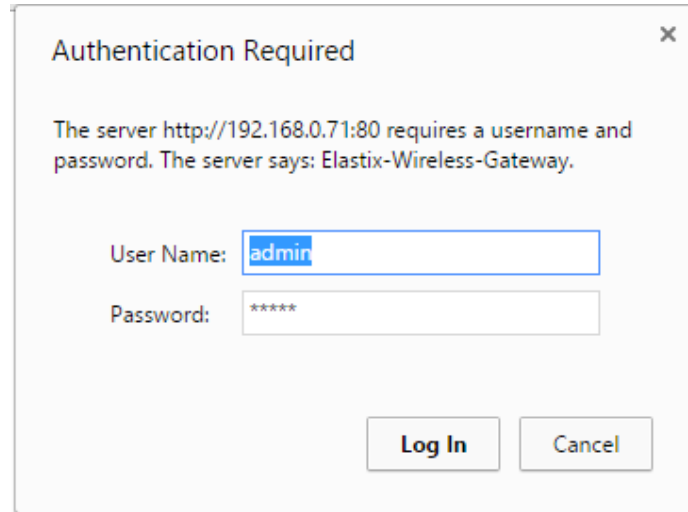

2. System

Status

On the “Status” page, you will find all GSM, SIP, Routing, Network information and status.

Figure 2-1-1 System Status

GSM Information									
Port	Signal	BER	Carrier	Registration Status	PDD(s)	ACD(s)	ASR(%)	GSM Status	Remain Time
gsm-1.1		0	74000	Registered (Home network)	0	0	0	READY	No Limit
gsm-1.2		-1		Undetected SIM Card	0	0	0		No Limit
gsm-1.3		0		Undetected SIM Card	0	0	0		No Limit
gsm-1.4		0		Undetected SIM Card	0	0	0		No Limit

SIP Information				
Endpoint Name	User Name	Host	Registration	SIP Status

Routing Information			
Rule Name	From	To	Rules

Network Information						
Name	MAC Address	IP Address	Mask	Gateway	RX Packets	TX Packets
LAN	A0:98:05:01:39:88	192.168.0.71	255.255.240.0	192.168.10.100	9539068	127805

Table 2-1-1 Description of System Status

Options	Definition
Port	Number of GSM ports.
Signal	Display the signal strength of in each channels of GSM.
BER	Bit Error Rate.
Carrier	Display the network carrier of current SIM card.
Registration Status	Indicates the registration status of current GSM module.
PDD	Post Dial Delay (PDD) is experienced by the originating customer as the time from the sending of the final dialed digit to the point at which they hear ring tone or other in-band information. Where the originating network is required to play an announcement before completing the call then this definition of PDD excludes the duration of such announcements.
ACD	The Average Call Duration (ACD) is calculated by taking the sum of billable seconds (bill sec) of answered calls and dividing it by the number of these answered calls.
ASR	Answer Seizure Ratio is a measure of network quality. Its calculated by taking the number of successfully answered calls and dividing by the total number of calls attempted. Since busy signals and other rejections by the called number count as call failures, the ASR value can vary depending on user behavior.
GSM Status	Show the status of port, include blank space and "READY". Black space means it is unavailable here and "Ready" means the port is available.
Remain Time	This value is multiplied by to step length is a rest call time.

Time

Table 2-2-1 Description of Time Settings

Options	Definition
System Time	Your gateway system time.
Time Zone	The world time zone. Please select the one which is the same or the closest as your city.
POSIX TZ String	Posix time zone strings.
NTP Server 1	Time server domain or hostname. For example, [pool.ntp.org].
NTP Server 2	The first reserved NTP server. For example, [time.windows.com].
NTP Server 3	The second reserved NTP server. For example, [time.nist.gov].
Auto-Sync from NTP	Whether enable automatically synchronize from NTP server or not. ON is enable, OFF is disable this function.
Sync from NTP	Sync time from NTP server.
Sync from Client	Sync time from local machine.

For example, you can configure like this:

Figure 2-2-1 Time Settings

Time Settings	
System Time:	2015-4-17 13:56:58
Time Zone:	Eastern Time ▼
POSIX TZ String:	EST5EDT,M3.2.0,M11.1.0
NTP Server 1:	pool.ntp.org
NTP Server 2:	time.windows.com
NTP Server 3:	time.nist.gov
Auto-Sync from NTP:	<input checked="" type="checkbox"/> ON <input type="checkbox"/>

You can set your gateway time Sync from NTP or Sync from Client by pressing different buttons.

Login Settings

Your gateway doesn't have administration role. All you can do here is to reset what new username and password to manage your gateway. And it has all privileges to operate your gateway. You can modify "Web Login Settings" and "SSH Login Settings". If you have changed these settings, you don't need to log out, just rewriting your new user name and password will be OK. Also you can specify the web server port number.

Table 2-3-1 Description of Login Settings

Options	Definition
User Name	Define your username and password to manage your gateway, without space here. Allowed characters "_+.<>&0-9a-zA-Z". Length: 1-32 characters.
Password	Allowed characters "_+.<>&0-9a-zA-Z". Length: 4-32 characters.
Confirm Password	Please input the same password as 'Password' above.
Port	Specify the web server port number.

Figure 2-3-1 Login Settings

Web Login Settings	
User Name:	<input type="text" value="user1"/>
Password:	<input type="password" value="....."/>
Confirm Password:	<input type="password" value="....."/>
Port:	<input type="text" value="80"/>

SSH Login Settings	
Enable:	<input type="checkbox"/> ON <input type="checkbox"/>
User Name:	<input type="text" value="admin"/>
Password:	<input type="text" value="admin"/>
Port:	<input type="text" value="12345"/>

Notice: Whenever you do some changes, do not forget to save your configuration.

General and Cluster

Language Settings

You can choose different languages for your system. If you want to change language, you can switch “Advanced” on, then “Download” your current language package. After that, you can modify the package with the language you need. Then upload your modified packages, “Choose File” and “Add”.

Figure 2-4-1 Language Settings

Language Settings	
Language:	<input type="text" value="English"/> ▾
Advanced:	<input type="checkbox"/> ON <input type="checkbox"/>
Language Debug:	<input type="checkbox"/> TURN ON <input type="checkbox"/> TURN OFF
Download:	Download selected language package. <input type="button" value="Download"/>
Delete:	Delete selected language. <input type="button" value="Delete"/>
Add New Language:	New language Package: <input type="button" value="Choose File"/> No file chosen <input type="button" value="Add"/>

Scheduled Reboot

If switch it on, you can manage your gateway to reboot automatically as you like. There are four reboot types for you to choose, “By Day, By Week, By Month and By Running Time”.

Figure 2-4-2 Reboot Types

Scheduled Reboot	
Enable:	<input checked="" type="checkbox"/> ON
Reboot Type:	By Day By Week By Month By Running Time
Time:	0

If use your system frequently, you can set this enable, it can helps system work more efficient.

Working Mode

Elastix GSM Gateway offers you two ways to cluster your gateway: Automatic Cluster or Manual Cluster.

When you first time log in your gateway, you will only see 4 ports of one module. Then you can press button, the system will search other modules in the LAN and communicate.

Figure 2-4-3 Automatic Cluster

Working Mode	
Action:	Automatic Cluster
Detail:	<input type="checkbox"/> OFF

If you want to choose **Manual Cluster**, you should switch **Detail** on first.

There are five modules which are independent with each other integrated in one GSM Gateway, so we offer 3 kinds of Working Modes.

Figure 2-4-4 Working Modes

Working Mode																																																			
Action:	Automatic Cluster																																																		
Detail:	<input type="checkbox"/> ON <input type="checkbox"/>																																																		
Mode:	Master <input type="button" value="Set Default"/>																																																		
Password:	<input type="text" value="98981"/>																																																		
Master IP(Local IP):	<input type="text" value="192.168.217.233"/>																																																		
Slaves IP List:	<table border="1"> <thead> <tr> <th>Board-2</th> <th>Original IP:</th> <td><input type="text" value="192.168.179.2"/></td> <th>Target IP:</th> <td><input type="text" value="192.168.217.234"/></td> </tr> </thead> <tbody> <tr> <td>Board-3</td> <td>Original IP:</td> <td><input type="text"/></td> <td>Target IP:</td> <td><input type="text"/></td> </tr> <tr> <td>Board-4</td> <td>Original IP:</td> <td><input type="text"/></td> <td>Target IP:</td> <td><input type="text"/></td> </tr> <tr> <td>Board-5</td> <td>Original IP:</td> <td><input type="text"/></td> <td>Target IP:</td> <td><input type="text"/></td> </tr> <tr> <td>Board-6</td> <td>Original IP:</td> <td><input type="text"/></td> <td>Target IP:</td> <td><input type="text"/></td> </tr> <tr> <td>Board-7</td> <td>Original IP:</td> <td><input type="text"/></td> <td>Target IP:</td> <td><input type="text"/></td> </tr> <tr> <td>Board-8</td> <td>Original IP:</td> <td><input type="text"/></td> <td>Target IP:</td> <td><input type="text"/></td> </tr> <tr> <td>Board-9</td> <td>Original IP:</td> <td><input type="text"/></td> <td>Target IP:</td> <td><input type="text"/></td> </tr> <tr> <td>Board-10</td> <td>Original IP:</td> <td><input type="text"/></td> <td>Target IP:</td> <td><input type="text"/></td> </tr> <tr> <td>Board-11</td> <td>Original IP:</td> <td><input type="text"/></td> <td>Target IP:</td> <td><input type="text"/></td> </tr> </tbody> </table>	Board-2	Original IP:	<input type="text" value="192.168.179.2"/>	Target IP:	<input type="text" value="192.168.217.234"/>	Board-3	Original IP:	<input type="text"/>	Target IP:	<input type="text"/>	Board-4	Original IP:	<input type="text"/>	Target IP:	<input type="text"/>	Board-5	Original IP:	<input type="text"/>	Target IP:	<input type="text"/>	Board-6	Original IP:	<input type="text"/>	Target IP:	<input type="text"/>	Board-7	Original IP:	<input type="text"/>	Target IP:	<input type="text"/>	Board-8	Original IP:	<input type="text"/>	Target IP:	<input type="text"/>	Board-9	Original IP:	<input type="text"/>	Target IP:	<input type="text"/>	Board-10	Original IP:	<input type="text"/>	Target IP:	<input type="text"/>	Board-11	Original IP:	<input type="text"/>	Target IP:	<input type="text"/>
	Board-2	Original IP:	<input type="text" value="192.168.179.2"/>	Target IP:	<input type="text" value="192.168.217.234"/>																																														
	Board-3	Original IP:	<input type="text"/>	Target IP:	<input type="text"/>																																														
	Board-4	Original IP:	<input type="text"/>	Target IP:	<input type="text"/>																																														
	Board-5	Original IP:	<input type="text"/>	Target IP:	<input type="text"/>																																														
	Board-6	Original IP:	<input type="text"/>	Target IP:	<input type="text"/>																																														
	Board-7	Original IP:	<input type="text"/>	Target IP:	<input type="text"/>																																														
	Board-8	Original IP:	<input type="text"/>	Target IP:	<input type="text"/>																																														
	Board-9	Original IP:	<input type="text"/>	Target IP:	<input type="text"/>																																														
	Board-10	Original IP:	<input type="text"/>	Target IP:	<input type="text"/>																																														
	Board-11	Original IP:	<input type="text"/>	Target IP:	<input type="text"/>																																														
Remain Original IP address:	<input type="checkbox"/> OFF																																																		
Action:	Manual Cluster																																																		

- Stand-alone Mode: Run alone, total 4 ports.
- Master Mode: Run as master with two different IP, controlling up to two slaves.
(The master can be accessed by the original IP. The target IP is used to communicate with the slaves.)
- Slave Mode: Run as slave with two different IP, controlled by the master. If the original IP is forbidden, the slave can be accessed by the master with inward IP only.

Notice: You can choose Remain Original IP address ON or OFF. If set it on, you can log in your getaway with Original IP and Target IP.

Table 2-4-1 Definition of Master Options

Options	Definition
Mode	Stand-alone Mode Master Mode Slave Mode
Password (master mode)	Master Mode password. Must be 4~16 bits digital 0-9.
Master IP(Local IP) (master mode)	Master's target IP. Must be set in the subnet different from external subnet, so that the external subnet couldn't access internal subnet.
Slaves IP List	Set the slaves's original and target IP. The original IP is outward IP, and the target IP is inward IP. Up to four slaves.

Tools and Information

On the “Tools” pages, there are reboot, update, upload, download and reset toolkits.

Reboot Tools

You can choose system reboot and Asterisk reboot separately.

Figure 2-5-1 Reboot Prompt

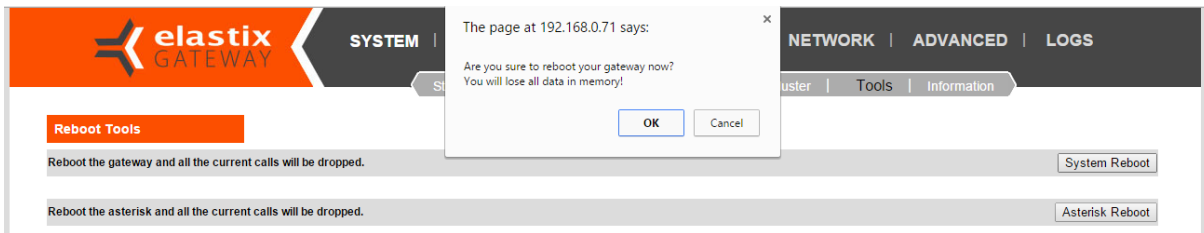

If you press “Yes”, your system will reboot and all current calls will be dropped. Asterisk Reboot is the same.

Table 2-5-1 Instruction of reboots

Options	Definition
System Reboot	This will turn off your gateway and then turn it back on. This will drop all current calls.
Asterisk Reboot	This will restart Asterisk and drop all current calls.

We offer 2 kinds of update types for you, you can choose System Update or System Online Update. System Online Update is an easier way to update your system, if you choose it, you will see some information below.

Figure 2-5-2 Prompt Information

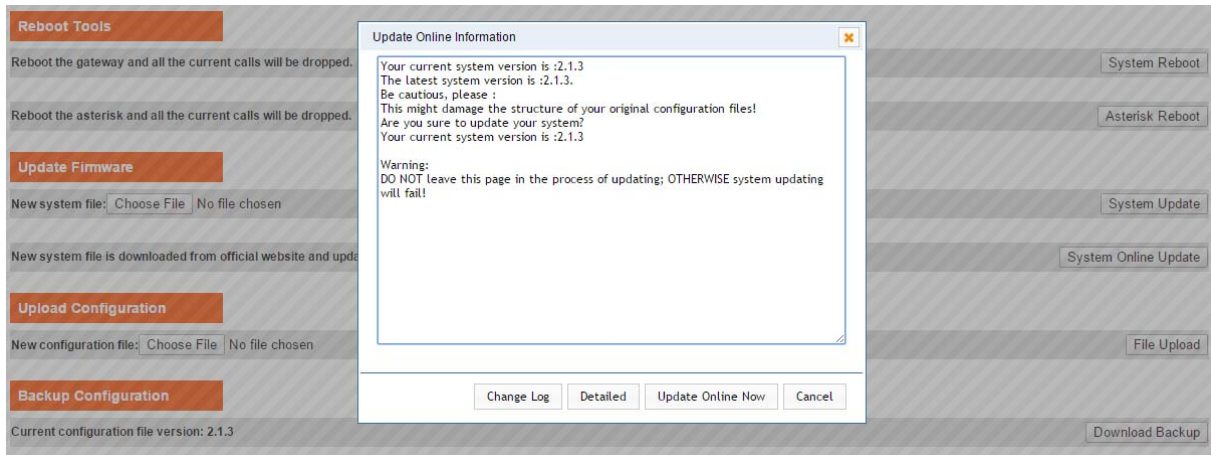

If you want to update your system and remain your previous configuration, you can first backup configuration, then you can upload configuration directly. That will be very convenient for you.

Figure 2-5-3 Upload and Download



Sometimes there is something wrong with your gateway that you don't know how to solve it, mostly you will select factory reset. Then you just need to press a button, your gateway will be reset to the factory status.

Figure 2-5-4 Factory Reset

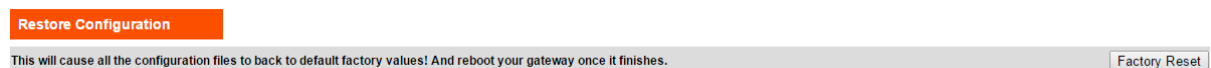

Information

On the "Information" page, there shows some basic information about the GSM gateway. You can see software and hardware version, storage usage, memory usage and some help information.

Figure 2-5-5 System Information









Model Name:	EGW200
GSM Modem Description:	GSM:850/900/1800/1900MHz
Software Version:	2.1.3
Hardware Version:	Date 2012-11-09 FPGA 11 Hardware 00
Slot Number:	1
Storage Usage:	1.7M/63.5M (3%)
Memory Usage:	63.1849 % Memory Clean
Build Time:	2015-03-19 12:00:56
Contact Address:	Cdla. Nueva Kennedy, Calle E No.222 - 9na Este, Guayaquil, Ecuador
Tel:	+1-877-ELASTIX (+1-877-3527849)
Fax:	+1-877-ELASTIX (+1-877-3527849) ext. 4503
E-Mail:	support@elastix.com
Web Site:	http://www.elastix.com
Rebooting Counts:	51
System Time:	2015-4-17 14:14:09
System Uptime:	8 days 00:26:56

3. GSM

You can see much information about your SIM cards on this page.

GSM Settings

Figure 3-1-1 GSM System

Port	Carrier	Registration Status	GSM Status	Actions
gsm-1.1	74000	Registered (Home network)	READY	 
gsm-1.2		Undetected SIM Card		 
gsm-1.3		Undetected SIM Card		 
gsm-1.4		Undetected SIM Card		 

On this page, you can see your GSM module status and click action  button to configure the port.

Figure 3-1-2 Port Configure

Port gsm-1.1	
Name:	<input type="text"/>
Speaker Volume:	<input type="text" value="70"/>
Microphone Volume:	<input type="text" value="1"/>
DAC Gain:	<input type="text" value="-15"/>
ADC Gain:	<input type="text" value="-3"/>
Dial Prefix:	<input type="text"/>
Pin Code:	<input type="text"/> <input type="checkbox"/> On
Custom AT commands when start:	<input type="text"/>
Echo Cancellation:	<input type="checkbox"/> OFF
CLIR:	<input type="checkbox"/> OFF
SMS Center Number:	+59395897705 <input type="button" value="Modify"/>
Band:	All Band(850/900/1800/1900MHz) ▼
SIM IMSI:	740000203310392
GSM Module IMEI:	865328021110274 <input type="button" value="Modify"/>
GSM Module Revision:	MTK 0828
Carrier:	74000
Bind Carrier:	Auto ▼ <input type="button" value="List Carrier"/>
Signal:	31
Own Number:	
BER:	0
Status:	READY

As you see, we have offered “Band” option, you can select different bands easily and you have many options.

Figure 3-1-3 Band Binding

Band:	All Band(850/900/1800/1900MHz) ▾
SIM IMSI:	All Band(850/900/1800/1900MHz)
GSM Module IMEI:	EGSM(850/900MHz) DCS(1800MHz) PCS(1900MHz)
GSM Module Revision:	EGSM DCS(850/900/1800MHz) GSM850 PCS(850/1900MHz)

If you have set your Pin Code, you can check on like this:

Figure 3-1-4 PIN Code Application

Pin Code:	<input type="text" value="123456"/>	<input checked="" type="checkbox"/> On
------------------	-------------------------------------	--

Then input your password, system will identify numbers of SIM cards. It can help to prevent SIM card from being stolen and improve security.

If you want to hide your number when you call out, you can just switch CLIR “ON” (Of course you need your operator’s support).

Figure3-1-5 CLIR Application

CLIR:	<input type="checkbox"/> ON <input type="checkbox"/>
--------------	--

If you have some voice quality problems, you can open Echo Cancellation for an attempt.

Figure3-1-6 Echo Cancellation

Echo Cancellation:	<input type="checkbox"/> ON <input type="checkbox"/>
---------------------------	--

IMEI Modification

One more feature, we offer you IMEI automatically modification.

Figure 3-1-7 Automatically IMEI Modify

GSM Module IMEI:	<input type="text" value="865328021110274"/>	<input type="button" value="Modify"/>
-------------------------	--	---------------------------------------

We have offered you IMEI modification function. If you want to modify your IMEI number, please do as follows.

You can log in your gateway and modify IP address as follows. Input web site below on your browser. <http://elastix.egw200.ip.address/cgi-bin/php/gsm-autoimei.php> . Then you will see the following picture. Don't forget to switch "Enable" to "ON", or you can't change your IMEI numbers.

Figure 3-1-8 IMEI Modification

Also you can choose to modify one or more certain ports or all ports. You can set automatic modification interval by filling in the time you want. **Interval:** **Second** If you choose "Immediately", then the ports you have chosen will modify IMEI numbers at once. On the contrary, system will keep time from now until the time of next modification. And If you choose "Force", System will hang up all your current calls, then modify IMEI.

You can press **Auto-IMEI Advanced** to do some settings. We offer you two ways to modify your IMEI. You can choose Autogeneration or Manual.

Figure 3-1-9 Advanced Settings

IMEI Number Setting	TAC(6 digit)	FAC(2 digit)	SNR(6 digit)	SP(1 digit)	Current IMEI	Action
Set to All	<input type="text" value="35xxxx"/>	<input type="text" value="0x"/>	<input type="text" value="xxxxxx"/>	<input type="text" value="Autogeneration"/>	None	<input type="button" value="Set to All"/>
gsm-1.1	<input type="text" value="35xxxx"/>	<input type="text" value="0x"/>	<input type="text" value="xxxxxx"/>	<input type="text" value="Autogeneration"/>	865328021110274	<input type="button" value="Manual"/>
gsm-1.2	<input type="text" value="35xxxx"/>	<input type="text" value="0x"/>	<input type="text" value="xxxxxx"/>	<input type="text" value="Autogeneration"/>	865328021110092	<input type="button" value="Manual"/>
gsm-1.3	<input type="text" value="35xxxx"/>	<input type="text" value="0x"/>	<input type="text" value="xxxxxx"/>	<input type="text" value="Autogeneration"/>	865328021106249	<input type="button" value="Manual"/>
gsm-1.4	<input type="text" value="35xxxx"/>	<input type="text" value="0x"/>	<input type="text" value="xxxxxx"/>	<input type="text" value="Autogeneration"/>	865328021106116	<input type="button" value="Manual"/>

As you can see, you can set any number you want for every port. "X" means any digits from 0 to 9. You just need to fill in "Set to All", then press "Set to All", you can see the interface as above. Don't forget to press "Save". Then "Current IMEI" will change. That means Autogeneration. If you want to set a certain number as your IMEI, you can press "Manual". Then you will be required to input a new IMEI.

Figure 3-1-10 Manual

Manual Modify IMEI

Old IMEI: 865328021110274. Please input new IMEI:

865328021110274

Force modify even if the port is not ready.

Modify Cancel

After configuration, you can press “Back Home” to return your gateway interface.

Table 3-1-1 Definition of GSM Settings

Options	Definition
Name	The alias of the GSM port. Input name without space here. Allowed characters "-_+.<>&0-9a-zA-Z".Length: 1-32 characters.
Speaker Volume	The speaker volume level, the range is 0-100. This will adjust the loud speaker volume level by an AT command.
Microphone Volume	The microphone volume, range is: 0-15. This will change the microphone gain level by an AT command.
DAC Gain	The range is: -42 to +20
ADC Gain	The range is: -42 to +20
Dial Prefix	The prefix number of outgoing calls from this GSM channel
PIN Code	Personal identification numbers of SIM card. PIN code can be modified to prevent SIM card from being stolen.
Custom AT commads when start	User custom AT commands when start system, use “ ” to split AT command.

CLIR	Caller ID restriction, this function is used to hidden caller ID of SIM card number. The gateway will add '#31#' in front of mobile number. This function must support by Operator.
SMS Center Number	Your SMS center number of your local carrier.
GSM Module IMEI	You can click "Modify" button and automatically modify it.

Call Duration Limit Settings

Now we can offer you two types of call duration limit, you can choose "Single Call Duration Limit" or "Call Duration Limitation" to control your calling time.

- **Single Call Duration Limit**

This will limit the time of each call.

Figure 3-1-11 Single Settings

▼ Call Duration Limit	
Step:	60 Second
Enable Single Call Duration Limit:	<input checked="" type="checkbox"/> ON
Single Call Duration Limitation:	1

First you need to switch "Enable" on, then you can set "Step" and "Single Call Duration Limitation" any digits you want. When you make a call by this port, it will limit your calling time within the product of

Step * Single Call Duration Limitation

And if your calling time overtops the value above, the system will hang up this call.

- **Call Duration Limitation**

This will limit your total calling time of this port.

Figure 3-1-12 Call Duration Limitation Settings

▼ Call Duration Limit	
Step:	60 Second
Enable Single Call Duration Limit:	<input type="checkbox"/> OFF
Enable Call Duration Limitation:	<input checked="" type="checkbox"/> ON
Call Duration Limitation:	10
Minimum Charging Time:	30 Second
Alarm Threshold:	2
Alarm Phone Number:	1861000100
Alarm Description:	test
Remain Time:	No Limit <input type="button" value="Reset"/>
Enable Auto Reset:	<input checked="" type="checkbox"/> ON
Auto Reset Type:	Day(1Day) ▼
Next Reset Time:	2015-04-17 14:41:02

The same algorithm with single time limitation, the total calling time of this port can't beyond the product of "Step" and "Call Duration Limitation".

If the duration of a call is less than "Minimum Charging Time", it will be not included in "Call Duration".

You can set a digit for "Alarm Threshold", when the call minutes less than this value, the gateway will send alarm info to designated phone.

You can enable your Auto Reset, then choose by day, by week, or by month.

Figure 3-1-13 Auto Reset Settings

Enable Auto Reset:	<input checked="" type="checkbox"/> ON
Auto Reset Type:	Day(1Day) ▼
Next Reset Time:	2015-04-17 14:41:02

You can save your configuration to other ports.

Figure 3-1-14 Save To Other Ports



If you have set like this, you will see many on the Web GUI, you can set whether to check.

Notice: When you do some changes, you need to Save and Apply, then “Remain Time” will show as you set.

Your calling status will show on the main interface.

Figure 3-1-15 GSM Information

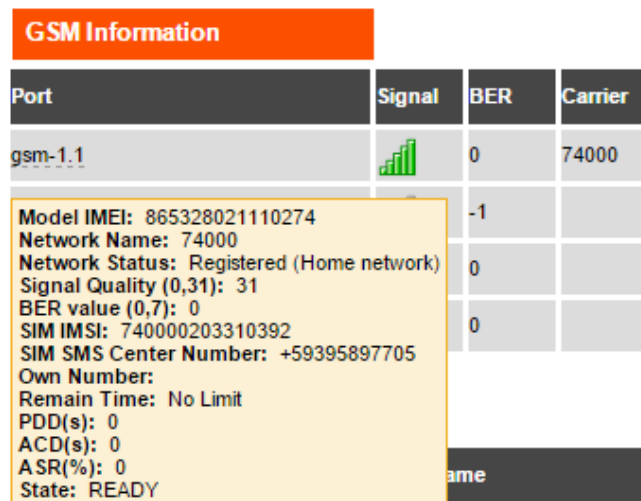

Table 3-1-2 Description of Call Duration Limit Settings

Options	Definition
Step	Step length value range is 1-120 s, step length multiplied by time of single call just said a single call duration time allowed.
Enable Single Call Duration Limit	Definite maximum call duration for single call. Example: if Time of single call set to 10, the call will be disconnected after talking 10*step seconds.
Enable Call Duration Limitation	This function is to limit the total call duration of GSM channel. The max call duration is between 1 to 65535 minutes.

Call Duration Limitation	The value of limitation single call, this value range is 1-65535. Step length multiplied by time of single call just said a single call duration time allowed.
Minimum Charging Time	A single call over this time, GSM side of the operators began to collect fees, unit for seconds.
Alarm Threshold	Define a threshold value of call minutes, while the call minutes less than this value, the gateway will send alarm information to designated phone.
Alarm Description	Alarm port information description, which will be sent to user mobile phone with alarm information.
Alarm Phone Number	Receiving alarm phone number, user will received alarm message from gateway.
Remain Time	This value is multiplied by to step length is a rest call time.
Enable Auto Reset	Automatic restore remaining talk time, that is, get total call minutes of GSM channel.
Auto Reset Type	Reset call minutes by date, by week, by month.
Next Reset Time	Defined next reset date, system will count start from that date and work as Reset Period setting

Call Forwarding

Sometimes it's not convenient for you to answer a call, if you don't want to lose some important calls, you can choose Call Forwarding. You can choose Call Forwarding Unconditional, Call Forwarding No Reply, Call Forwarding Busy or Call Forwarding on Not Reachable. If want to cancel your call forwarding settings, you can choose Cancel All.

Figure 3-2-1 Call Forwarding

Port	Select	Call Type	Call Number	Status
gsm-1.1	<input type="radio"/>	Call Forwarding Unconditional	<input type="text"/>	
	<input checked="" type="checkbox"/>	Call Forwarding No Reply	<input type="text"/>	
	<input checked="" type="checkbox"/>	Call Forwarding Busy	<input type="text"/>	
	<input type="checkbox"/>	Call Forward on Not Reachable	<input type="text"/>	
	<input type="radio"/>	Cancel All		
gsm-1.2	<input type="radio"/>	Call Forwarding Unconditional	<input type="text"/>	
	<input type="checkbox"/>	Call Forwarding No Reply	<input type="text"/>	
	<input type="checkbox"/>	Call Forwarding Busy	<input type="text"/>	
	<input type="checkbox"/>	Call Forward on Not Reachable	<input type="text"/>	
	<input type="radio"/>	Cancel All		

Notice: Don't forget to save your settings. Please first press button, then press button.

DTMF

You can do some DTMF Detection Settings if you choose “GSM -> DTMF”.

Figure 3-3-1 DTMF Detection Settings

DTMF Detection Settings	
Reference Value:	Default ▼
Relax DTMF Normal Twist:	6.31 8.00dB
Relax DTMF Reverse Twist:	3.98 5.99dB
DTMF Relative Peak Row:	6.3 7.99dB
DTMF Relative Peak Col:	6.3 7.99dB
DTMF Hits Begin:	2
DTMF Misses End:	3

Notice: If you don't have special need, you don't have to modify these settings. You can just choose “Default”.

- DTMF Normal Twist and Reverse Twist is the difference in power between the row and column energies. Normal Twist is where the Column energy is greater than the Row energy. Reverse Twist is where the Row energy is greater.
- DTMF Relative Peak Row: The value is the smaller and the detection is easier. If you lost some numbers, you can try to put the value down. The adjustment range is 0.02 at a time.
- DTMF Relative Peak Col: The value is smaller and the detection is easier. If you lost some numbers, you can try to put the value down. The adjustment range is 0.1 at a time.
- DTMF Hits Begin: Sampling matching value. You can choose 2 or 3.
- DTMF Misses End: The time interval between the two digits you input. Adjust the speed of input. The smaller value represents the shorter intervals.

Toolkit

You can get USSD information, send AT command and check number with this module. When you have a debug of the GSM module, AT command is useful.

Figure 3-4-1 Function Options

The screenshot shows the Toolkit interface. At the top, there is a 'Function:' dropdown menu with 'Get USSD' selected. Below it, an 'Action:' dropdown menu is open, showing three options: 'Get USSD', 'Send AT Command', and 'Check Number'. To the right of the 'Action:' dropdown are three buttons: 'Copy to Selected', 'Clear All', and 'Execute'. Below this is a table with four columns: 'Port', 'Input', and 'Output'. The 'Port' column has a checkbox next to each port name: gsm-1.1, gsm-1.2, gsm-1.3, and gsm-1.4. The 'Input' and 'Output' columns are empty text boxes.

Port	Input	Output
<input type="checkbox"/> gsm-1.1		
<input type="checkbox"/> gsm-1.2		
<input type="checkbox"/> gsm-1.3		
<input type="checkbox"/> gsm-1.4		

Table 3-4-1 Definition of Functions

Options	Definition
Check Number	Enter a known number (like your mobile phone) to check what number it is of the SIM card. Click "Execute", then the gateway will dial to the number you already input. It only rings for one time and hangs up at once. Not generating telephone charge during this procedure.
Get USSD	Enter a specific USSD number (For example, *142# to check your SIM card's balance. This USSD number is might be different from different carriers) to get the USSD information. The gateway will try to get by AT commands.
AT Command	To perform some specific AT commands. This is useful when you have a debug of the GSM modem. e.g. perform [AT+CSQ] to check what signal qualify it is. In AT commands, there is no difference between "a" and "A".

If you want to send AT command, first you should input your command, then select certain ports and choose "Copy to Selected", finally choose "Execute".

Figure 3-4-2 AT Command Example

Function:		Send AT Command ▾	
Action:		AT+CSQ	<input type="button" value="Copy to Selected"/> <input type="button" value="Clear All"/> <input type="button" value="Execute"/>
<input type="checkbox"/>	Port	Input	Output
<input type="checkbox"/>	gsm-1.1	AT+CSQ	+CSQ: 31,0 OK

4. SIP and Routing

SIP Endpoints

This page shows everything about your SIP, you can see status of each SIP.

Figure 4-1-1 SIP Status

Endpoint Name	Registration	Credentials	Actions
200	client	200@192.168.5.58	 
TEL1	server	301	 

Main Endpoint Settings

You can click button to add a new SIP endpoint, and if you want to modify existed endpoints, you can click  button.

There are 3 kinds of registration types for choose. You can choose Anonymous, Endpoint registers with this gateway or this gateway registers with the endpoint.

You can configure as follows:

If you set up a SIP endpoint by registration “None” to a server, then you can’t register other SIP endpoints to this server. (If you add other SIP endpoints, this will cause Out-band Routes and Trunks confused.)

Figure 4-1-2 Anonymous Registration

▼ Main Endpoint Settings

Name:	1000
User Name:	<input type="text"/> <input checked="" type="checkbox"/> Anonymous
Password:	<input type="password"/>
Registration:	None ▼
Hostname or IP Address:	172.16.0.80
Transport:	UDP ▼
NAT Traversal:	Yes ▼

For convenience, we have designed a method that you can register your SIP endpoint to your gateway, thus your gateway just work as a server.

Figure 4-1-3 Register to Gateway

▼ Main Endpoint Settings

Name:	1001
User Name:	1001 <input type="checkbox"/> Anonymous
Password: <input type="password"/>
Registration:	Endpoint registers with this gateway ▼
Hostname or IP Address:	dynamic
Transport:	UDP ▼
NAT Traversal:	Yes ▼

Also you can choose registration by “This gateway registers with the endpoint”, it’s the same with “None”, except name and password.

Figure 4-1-4 Register to Server

▼ Main Endpoint Settings

Name:	80100
User Name:	80100 <input type="checkbox"/> Anonymous
Password:
Registration:	This gateway registers with the endpoint ▼
Hostname or IP Address:	172.16.0.88
Transport:	UDP ▼
NAT Traversal:	Yes ▼

Table 4-1-1 Definition of SIP Options

Options	Definition
Name	Display name.
Username	Register name in your SIP server.
Password	Authenticating with the gateway and characters are allowed.
Registration	<p>None---Not registering;</p> <p>Endpoint registers with this gateway---When register as this type, it means the GSM gateway acts as a SIP server, and SIP endpoints register to the gateway;</p> <p>This gateway registers with the endpoint---When register as this type, it means the GSM gateway acts as a client, and the endpoint should be register to a SIP server;</p>
Hostname or IP Address	IP address or hostname of the endpoint or 'dynamic' if the endpoint has a dynamic IP address. This will require registration.
Transport	This sets the possible transport types for outgoing. Order of usage, when the respective transport protocols are enabled, is UDP, TCP, TLS. The first enabled transport type is only used for outbound messages until a Registration takes place. During the peer Registration the transport type may change to another supported type if the peer requests so.

NAT Traversal	<p>No---Use Rport if the remote side says to use it.</p> <p>Force Rport on---Force Rport to always be on.</p> <p>Yes---Force Rport to always be on and perform comedia RTP handling.</p> <p>Rport if requested and comedia---Use Rport if the remote side says to use it and perform comedia RTP handling.</p>
---------------	--

Advanced: Registration Options

Table 4-1-2 Definition of Registration Options

Options	Definition
Authentication User	A username to use only for registration.
Register Extension	When Gateway registers as a SIP user agent to a SIP proxy (provider), calls from this provider connect to this local extension.
From User	A username to identify the gateway to this endpoint.
From Domain	A domain to identify the gateway to this endpoint.
Remote Secret	A password which is only used if the gateway registers to the remote side.
Port	The port number the gateway will connect to at this endpoint.
Quality	Whether or not to check the endpoint's connection status.
Qualify Frequency	How often, in seconds, to check the endpoint's connection status.

Call Settings

Table 4-1-3 Definition of Call Options

Options	Definition
DTMF Mode	Set default DTMF Mode for sending DTMF. Default: rfc2833. Other options: 'info', SIP INFO message (application/dtmf-relay); 'Inband', Inband audio (require 64kbit codec -alaw, ulaw).
Trust Remote-Party-ID	Whether or not the Remote-Party-ID header should be trusted.
Send Remote-Party-ID	Whether or not to send the Remote-Party-ID header.
Remote Party ID Format	How to set the Remote-Party-ID header: from Remote-Party-ID or from P-Asserted-Identity.
Caller ID Presentation	Whether or not to display Caller ID.

Advanced: Signaling Settings

Table 4-1-4 Definition of Signaling Options

Options	Definition
Progress Inband	Set default DTMF Mode for sending DTMF. Default: rfc2833. Other options: 'info', SIP INFO message (application/dtmf-relay); 'inband', Inband audio (require 64kbit codec -alaw, ulaw).
Allow Overlap Dialing	Whether or not the Remote-Party-ID header should be trusted.
Append user=phone to URI	Whether or not to send the Remote-Party-ID header.
Add Q.850 Reason Headers	How to set the Remote-Party-ID header: from Remote-Party-ID or from P-Asserted-Identity.
Honor SDP Version	Whether or not to display Caller ID.

Allow Transfers	Whether or not to globally enable transfers. Choosing 'no' will disable all transfers (unless enabled in peers or users). Default is enabled.
Allow Promiscuous Redirects	Whether or not to allow 302 or REDIR to non-local SIP address. Note that promiscredir when redirects are made to the local system will cause loops since this gateway is incapable of performing a "hairpin" call.
Max Forwards	Setting for the SIP Max-Forwards header (loop prevention).
Send TRYING on REGISTER	Send a 100 Trying when the endpoint registers.
Outbound Proxy	A proxy to which the gateway will send all outbound signaling instead of sending signaling directly to endpoints.

Advanced: Timer Settings

Table 4-1-5 Definition of Timer Options

Options	Definition
Default T1 Timer	This timer is used primarily in INVITE transactions. The default for Timer T1 is 500ms or the measured run-trip time between the gateway and the device if you have qualify=yes for the device.
Call Setup Timer	If a provisional response is not received in this amount of time, the call will auto-congest. Defaults to 64 times the default T1 timer.
Session Timers	Session-Timers feature operates in the following three modes: originate, Request and run session-timers always; accept, run session-timers only when requested by other UA; refuse, do not run session timers in any case.
Minimum Session Refresh Interval	Minimum session refresh interval in seconds. Default is 90secs.
Maximum Session Refresh Interval	Maximum session refresh interval in seconds. Defaults to 1800secs.
Session Refresher	The session refresher, uac or uas. Defaults to uas.

Advanced SIP Settings

Networking

Table 4-2-1 Definition of Networking Options

Options	Definition
UDP Bind Port	Choose a port on which to listen for UDP traffic.
Enable TCP	Enable server for incoming TCP connection (default is no).
TCP Bind Port	Choose a port on which to listen for TCP traffic.
TCP Authentication Timeout	The maximum number of seconds a client has to authenticate. If the client does not authenticate before this timeout expires, the client will be disconnected. (default value is: 30 seconds).
TCP Authentication Limit	The maximum number of unauthenticated sessions that will be allowed to connect at any given time (default is:50).
Enable Hostname Lookup	Enable DNS SRV lookups on outbound calls Note: the gateway only uses the first host in SRV records Disabling DNS SRV lookups disables the ability to place SIP calls based on domain names to some other SIP users on the Internet specifying a port in a SIP peer definition or when dialing outbound calls with suppress SRV lookups for that peer or call.
Enable Internal SIP Call	Whether enable the internal SIP calls or not when you select the registration option "Endpoint registers with this gateway".
Internal SIP Call Prefix	Specify a prefix before routing the internal calls.
Local Network	Format:192.168.0.0/255.255.0.0 or 172.16.0.0./12. A list of IP address or IP ranges which are located inside a NATed network. This gateway will replace the internal IP address in SIP and SDP messages with the external IP address when a NAT exists between the gateway and other endpoints.

Local Network List	Local IP address list that you added.
Subscribe Network Change Event	Through the use of the test_stun_monitor module, the gateway has the ability to detect when the perceived external network address has changed. When the stun_monitor is installed and configured, chan_sip will renew all outbound registrations when the monitor detects any sort of network change has occurred. By default this option is enabled, but only takes effect once res_stun_monitor is configured. If res_stun_monitor is enabled and you wish to not generate all outbound registrations on a network change, use the option below to disable this feature.

Advanced: NAT Settings

Table 4-2-2 Definition of NAT Settings Options

Options	Definition
Match External Address Locally	Only substitute the externaddr or externhost setting if it matches.
Dynamic Exclude Static	Disallow all dynamic hosts from registering as any IP address used for statically defined hosts. This helps avoid the configuration error of allowing your users to register at the same address as a SIP provider.
Externally Mapped TCP Port	The externally mapped TCP port, when the gateway is behind a static NAT or PAT.
External Hostname	The external hostname (and optional TCP port) of the NAT.
Hostname Refresh Interval	How often to perform a hostname lookup. This can be useful when your NAT device lets you choose the port mapping, but the IP address is dynamic. Beware, you might suffer from service disruption when the name server resolution fails.

Start of RTP Port Range	Start of range of port numbers to be used for RTP.
End of RTP port Range	End of range of port numbers to be used for RTP.

Parsing and Compatibility

Table 4-2-3 Instruction of Parsing and Compatibility

Options	Definition
Strict RFC Interpretation	Check header tags, character conversion in URIs, and multiline headers for strict SIP compatibility(default is yes)
Send Compact Headers	Send compact SIP headers
SDP Owner	Allows you to change the username filed in the SDP owner string. This filed MUST NOT contain spaces.
Disallowed SIP Methods	The external hostname (and optional TCP port) of the NAT.
Shrink Caller ID	The shrinkcallerid function removes '(', ' ', ')', non-trailing '.', and '-' not in square brackets. For example, the caller id value 555.5555 becomes 5555555 when this option is enabled. Disabling this option results in no modification of the caller id value, which is necessary when the caller id represents something that must be preserved. By default this option is on.
Maximum Registration Expiry	Maximum allowed time of incoming registrations and subscriptions (seconds).
Minimum Registration Expiry	Minimum length of registrations/subscriptions (default 60).
Default Registration Expiry	Default length of incoming/outgoing registration.

Registration Timeout	How often, in seconds, to retry registration calls. Default 20 seconds.
Number of Registration Attempts Enter '0' for unlimited	Number of registration attempts before we give up. 0 = continue forever, hammering the other server until it accepts the registration. Default is 0 tries, continue forever.

Security

Table 4-2-4 Instruction of Security

Options	Definition
Match Auth Username	If available, match user entry using the 'username' field from the authentication line instead of the 'from' field.
Realm	Realm for digest authentication. Realms MUST be globally unique according to RFC 3261. Set this to your host name or domain name.
Use Domain as Realm	Use the domain from the SIP Domains setting as the realm. In this case, the realm will be based on the request 'to' or 'from' header and should match one of the domain. Otherwise, the configured 'realm' value will be used.
Always Auth Reject	When an incoming INVITE or REGISTER is to be rejected, for any reason, always reject with an identical response equivalent to valid username and invalid password/hash instead of letting the requester know whether there was a matching user or peer for their request. This reduces the ability of an attacker to scan for valid SIP usernames. This option is set to 'yes' by default.
Authenticate Options Requests	Enabling this option will authenticate OPTIONS requests just like INVITE requests are. By default this option is disabled.
Allow Guest Calling	Allow or reject guest calls (default is yes, to allow). If your gateway is connected to the Internet and you allow guest calls, you want to check which services you offer everyone out there, by enabling them in the default context.

Media

Table 4-2-5 Instruction of Media

Options	Definition
Premature Media	Some ISDN links send empty media frames before the call is in ringing or progress state. The SIP channel will then send 183 indicating early media which will be empty - thus users get no ring signal. Setting this to "yes" will stop any media before we have call progress (meaning the SIP channel will not send 183 Session Progress for early media). Default is 'yes'. Also make sure that the SIP peer is configured with progressinband=never. In order for 'noanswer' applications to work, you need to run the progress() application in the priority before the app.
TOS for SIP Packets	Sets type of service for SIP packets
TOS for RTP Packets	Sets type of service for RTP packets

Codec Settings

Select codecs from the list below.

Figure 4-2-1 Codec Settings

▼ Codec Settings

Codec Priority 1:	G.711 u-law ▼
Codec Priority 2:	G.711 a-law ▼
Codec Priority 3:	GSM ▼
Codec Priority 4:	G.722 ▼
Codec Priority 5:	G.723 ▼
Codec Priority 6:	G.726 ▼
Codec Priority 7:	G.729 ▼

5. Routing

Figure 5-1-1 Routing Rules

Move	Order	Rule Name	From	To	Rules	Actions
	1	SIP2GSM	Any SIP	gsm-1.1		
	2	gsm2sip	gsm-1.1	sip-200		

You are allowed to set up new routing rule by , and after setting routing rules, move rules' order by pulling up and down, click button to edit the routing and to delete it. Finally click the button to save what you set. **Rules** shows current routing rules. Otherwise you can set up unlimited routing rules.

Call Routing Rule

You can click button to set up your routings.

Figure 5-1-2 Example of set up Routing Rule

▼ Call Routing Rule

Routing Name:	<input style="width: 80%;" type="text" value="support"/>
Call Comes in From:	<input style="width: 80%;" type="text" value="200"/>
Send Call Through:	<input style="width: 80%;" type="text" value="gsm-1.2"/>

▼ Advance Routing Rule

Dial Patterns that will use this Route

(prepend))+9		[/ Callerid]	✖
-----------	-----	--	---	------------	---	---

The figure above realizes that calls from “support” SIP endpoints which you have registered will be transferred to gsm-1. When “Call Comes in From” is gsm, “prepend”, “prefix” and “match pattern” in “Advanced Routing Rule” are ineffective, and just “CallerID” option is available.

Table 5-1-1 Definition of Routing Options

Options	Definition
Routing Name	The name of this route. Should be used to describe what types of calls this route matches (for example, 'SIP2GSM' or 'GSM2SIP').
Call Comes in From	The launching point of incoming calls.
Send Call Through	The destination to receive the incoming calls.

Table 5-1-2 Description of Advanced Routing Rule

Options	Definition
Dial Patterns that will use this Route	<p>A Dial Pattern is a unique set of digits that will select this route and send the call to the designated trunks. If a dialed pattern matches this route, no subsequent routes will be tried. If Time Groups are enabled, subsequent routes will be checked for matches outside of the designated time(s).</p> <p>Rules:</p> <p>X matches any digit from 0-9</p> <p>Z matches any digit from 1-9</p> <p>N matches any digit from 2-9</p> <p>[1237-9] matches any digit in the brackets (example: 1,2,3,7,8,9)</p> <p>. wildcard: matches one or more dialed digits.</p> <p>prepend: Digits to prepend to a successful match.</p> <p>If the dialed number matches the patterns specified by the subsequent columns, then this will be prepended before sending to the trunks.</p> <p>prefix: Prefix to remove on a successful match.</p> <p>The dialed number is compared to this and the subsequent columns for a match.</p> <p>Upon a match, this prefix is removed from the dialed number before sending it to the trunks.</p>

	<p>match pattern: The dialed number will be compared against the prefix + this match pattern.</p> <p>Upon a match, the match pattern portion of the dialed number will be sent to the trunks</p> <p>Caller ID: If Caller ID is supplied, the dialed number will only match the prefix + match pattern if the Caller ID has been transmitted matches this. When extensions make outbound calls, the Caller ID will be their extension number and NOT their Outbound CID.</p> <p>The above special matching sequences can be used for Caller ID matching similar to other number matches.</p>
Set the Caller ID Name to	What caller ID name would you like to set before sending this call to the endpoint.
Set the Caller ID Number to	What caller number would you like to set before sending this call to the endpoint.
Forward Number	What destination number will you dial? This is very useful when you have a transfer call.
Failover Call Through Number	The gateway will attempt to send the call out each of these in the order you specify.

You can create various time routes and use these time conditions to limit some specific calls.

Figure 5-1-3 Time Patterns that will use this Route

If you configure like this, then from January to March, from the first day to the last day of these months, from Monday to Thursday, from 00:00 to 02:00, during this time (meet all above time conditions), all calls will follow this route. And the time will synchronize with your Sever time.

Figure 5-1-4 Time Reference

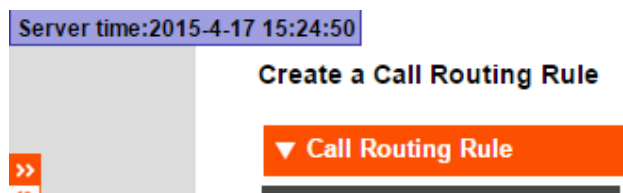

You set your caller ID name and caller number as you like before sending the call to the endpoint. You can also configure forward number when you have a transfer call.

Figure 5-1-5 Change Rules

Change Rules	
Set the Caller ID Name to	<input type="text"/>
Set the Caller ID Number to	<input type="text"/>
Forward Number	<input type="text"/>

You can add one or more “Failover Call Through Numbers”.

Figure 5-1-6 Failover Call Through Number

Failover Call Through Number	
Failover Call Through Number 1:	<input type="text" value="gsm-1.3"/> ▼
Failover Call Through Number 2:	<input type="text" value="gsm-1.4"/> ▼
<input type="button" value="Add a Failover Call Through Provider"/>	

Groups

Sometimes you want to make a call through one port, but you don’t know if it is available, so you have to check which port is free. That would be troublesome. But with our product, you don’t need to worry about it. You can combine many GSM or SIP to groups. Then if you want to make a call, it will find available port automatically.

Figure 5-2-1 Establish Group

Routing Groups																
Group Name:	<input type="text" value="ALL"/>															
Type:	<input type="text" value="GSM"/> ▼															
Policy:	<input type="text" value="Roundrobin"/> ▼															
Members	<table border="0"> <tr> <td>NO.</td> <td><input checked="" type="checkbox"/></td> <td>All</td> </tr> <tr> <td>1</td> <td><input checked="" type="checkbox"/></td> <td>gsm-1.1</td> </tr> <tr> <td>2</td> <td><input checked="" type="checkbox"/></td> <td>gsm-1.2</td> </tr> <tr> <td>3</td> <td><input checked="" type="checkbox"/></td> <td>gsm-1.3</td> </tr> <tr> <td>4</td> <td><input checked="" type="checkbox"/></td> <td>gsm-1.4</td> </tr> </table>	NO.	<input checked="" type="checkbox"/>	All	1	<input checked="" type="checkbox"/>	gsm-1.1	2	<input checked="" type="checkbox"/>	gsm-1.2	3	<input checked="" type="checkbox"/>	gsm-1.3	4	<input checked="" type="checkbox"/>	gsm-1.4
NO.	<input checked="" type="checkbox"/>	All														
1	<input checked="" type="checkbox"/>	gsm-1.1														
2	<input checked="" type="checkbox"/>	gsm-1.2														
3	<input checked="" type="checkbox"/>	gsm-1.3														
4	<input checked="" type="checkbox"/>	gsm-1.4														

MNP Settings

Mobile Number Portability allows switching between mobile phone operators without changing the mobile number. Sounds simple, but there are loads of tasks performed behind the scene at the operator end.

The URL is shown in the password string way. So please type the url in other place such a txt file, check it, then copy it to the gateway. The outgoing number in the url should be replaced by the variables $\${num}$.

Here is an example of the MNP url:

```
https://s1.bichara.com.br:8181/chkporta.php?user=832700&pwd=sdsfdg&tn=8388166902
```

The 8388166902 is the outgoing phone number, when config the MNP url, should replce it with $\${num}$. Then it turns to

```
https://s1.bichara.com.br:8181/chkporta.php?user=832700&pwd=sdsfdg&tn=${num }.
```

Figure 5-3-1 MNP Settings

MNP Settings	
MNP Check Enable:	<input checked="" type="checkbox"/> ON <input type="checkbox"/>
MNP URL:	<input type="text"/>
MNP Timeout:	<input type="text"/>
Manipulation Choice:	<input checked="" type="radio"/> Route calls after manipulation <input type="radio"/> Route calls before manipulation

6. SMS

SMS Settings

General

You can choose to enable SMS received, SMS local stored and SMS status report or not. But if you want to see your SMS outbox, you should switch SMS Status Report ON.

Figure 6-1-1 SMS Settings

Sender Options

You can change sender options here, include resend, times of resend.

Figure 6-1-2 Sender Options

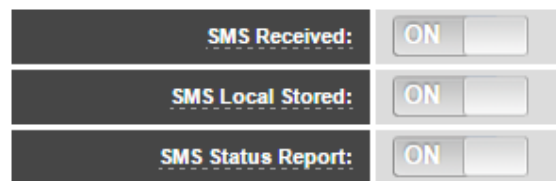

Table 6-1-1 Description of Sender Options

Options	Definition
Resend Failed Message	The times that you will attempt to resend your failed message.
Repeat Same Message	The times that you will resend the same message.
Verbose	Verbose level of sending message

SMS to E-mail

This is a tool that makes it available for you to email account to transmit the SMS to other email boxes.

Figure 6-1-3 SMS to E-mail Options

SMS to Email	
Enable:	<input type="checkbox"/> OFF <input checked="" type="checkbox"/> ON
SMTP Server:	OTHER ▼
Email Address of Sender:	example@gmail.com
Domain:	smtp.gmail.com
SMTP Port(default 25):	587
SMTP User Name:	example@gmail.com
SMTP Password:
TLS Enable:	<input checked="" type="checkbox"/> This option allows the authentication with certificates.
Destination Email Address 1:	example@gmail.com
Destination Email Address 2:	example@hotmail.com
Destination Email Address 3:	example2@hotmail.com
Title:	support
Content:	We can offer you support 24/7

Table 6-1-2 Types of E-mail Box

E-mail Box Type	SMTP Server	SMTP Port	SMTP Security Connectivity
Gmail	smtp.gmail.com	587	√
HotMail	smtp.live.com	587	√
Yahoo!	smtp.mail.yahoo.co.in	587	×
Other: 163 free e-mail	smtp.163.com	25	×

Table 6-1-3 Definition of SMS to E-mail

Options	Definition
Enable	When you choose on, the following options are available, otherwise, unavailable.
Email Address of Sender	To set the email address of an available email account. For example, example@gmail.com.
Domain	To set outgoing mail server. e.g. smtp.gmail.com
SMTP Port	To set port number of outgoing mail server. (Default is 25)
SMTP User Name	The login name of your existing email account. This option might be different from your email address. Some email client doesn't need the email postfix.
SMTP Password	The password to login your existing email.
TLS Enable	When you choose Yahoo and 163 free e-mails, this option is not available.
SMTP Server	To set outgoing mail server. e.g. mail.elastix.com
Destination Email Address1	The first email address to receive the inbox message.
Destination Email Address2	The second email address to receive the inbox message.
Destination Email Address3	The third email address to receive the inbox message.

SMS Control

Allowing endpoints to send some specific KEY WORDS and corresponding PASSWORD to operate the gateway and message is case-sensitive. In default, this function is disabled.

Figure 6-1-4 SMS Control

SMS Control	
Enable:	<input type="checkbox"/> ON <input type="checkbox"/>
Password:	<input type="text" value="123456789"/>
SMS Formats:	reboot system PASSWORD reboot asterisk PASSWORD restore config PASSWORD get info PASSWORD
SMS Inbox Auto clean:	<input type="checkbox"/> ON <input type="checkbox"/> maxsize: <input type="text" value="20MB"/>

For example, SMS control password is 123456789 which has nothing to do with the login password, you can send “get info 123456789” to the GSM module’s phone number to get your gateway’s IP information.

Table 6-1-4 Definition of SMS Control

Enable	ON(enable), OFF(disable)
Password	The password to confirm that SMS makes the gateway rebooted, shut down, restored configuration files and get info on this gateway.
SMS Format	For example, the message formats: reboot system PASSWORD: To reboot your whole gateway. The PASSWORD is referring to the PASSWORD you set up from option “PASSWORD” above. Reboot asterisk PASSWORD: To restart your gateway core. Restore configs PASSWORD: To reset the configuration files back to the default factory settings. Get info PASSWORD: To get your gateway IP address.
SMS inbox Auto clean	switch on: When the size of the SMS inbox record file reaches the max size, the system will cut a half of the file. New record will be retained. switch off: SMS record will remain, and the file size will increase gradually. default on, max size = 20 MB

SMS Sender

You can choose one or more ports to send SMS to the destination number, different numbers should be separated by symbols: '\r', '\n', space character, semicolon and comma.

Then you can see much feedback information.

Figure 6-2-1 SMS Sender Status

Port:	<input checked="" type="checkbox"/> gsm-1.1 <input type="checkbox"/> gsm-1.2 <input checked="" type="checkbox"/> gsm-1.3 <input type="checkbox"/> gsm-1.4
Flash SMS:	<input type="button" value="OFF"/>
Load numbers from text file:	<input type="button" value="Choose File"/> No file chosen
Destination Number:	<input type="text" value="091230,091231,091232,091233"/>
Message:	<input type="text" value="Hello World"/>
Action:	<input type="button" value="Send"/> <input type="button" value="Stop"/>

Total	Success	Fail
1	1	0

Message	Destination Number	Port	Repeat times	Attempt times	Result
Hello World	091230,091231,091232,091233	gsm-1.1	1	0	SUCCESS

SMS Inbox

On this page, you are allowed to scan, delete, clean up, and export each port's received SMS. Also you are allowed to check messages by port, phone number, time order and message keywords.

Figure 6-3-1 SMS Information

Port	Phone Number	Time	Message Keywords
<input type="text" value="all"/>	<input type="text"/>	<input type="text" value="2015/04/17 00:00:00"/> <input type="text" value="2015/04/17 23:59:00"/>	<input type="text"/>



Total Records: 1

<input type="checkbox"/>	Port	Phone Number	Time	Message
<input type="checkbox"/>	gsm-1.1	091230,091231,091232,091233	2015/04/17 15:15:31	get info 123456789

SMS Outbox

You will see your SMS recorder if you have enabled SMS Status Report on this page.

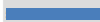
Figure 6-4-1 SMS Outbox

Port	Receiver	Time	Message
gsm-1.1		2015-04-17 16:15:42	LAN IP:192.168.0.71 WAN_IP:
gsm-1.1		2015-04-17 16:20:15	Hello World

7. Network

On “Network” page, there are five sub-pages, “LAN Settings”, “DDNS Settings”, and “Toolkit”.

LAN Settings

There are three types of LAN port IP, Factory, Static and DHCP. Factory is the default type, and it is 172.16.99.1. When you Choose LAN IPv4 type is “Factory”, this page is not editable.

A reserved IP address to access in case your gateway IP is not available. Remember to set a similar network segment with the following address of your local PC.

Figure 7-1-1 LAN Settings Interface

LAN IPv4	
Interface:	eth0
Type:	Static ▼
MAC:	A0:98:05:01:39:88
IPv4 Settings	
Address:	192.168.0.71
Netmask:	255.255.240.0
Default Gateway:	192.168.10.100
DNS Servers	
DNS Server 1:	8.8.8.8
DNS Server 2:	192.168.10.100
DNS Server 3:	
DNS Server 4:	
Reserved Access IP	
Enable:	ON <input type="checkbox"/>
Reserved Address:	192.168.99.1
Reserved Netmask:	255.255.255.0

Table 7-1-1 Definition of LAN Settings

Options	Definition
Interface	The name of network interface.
Type	The method to get IP. Factory: Getting IP address by Slot Number (System → information to check slot number). Static: manually set up your gateway IP. DHCP: automatically get IP from your local LAN.
MAC	Physical address of your network interface.
Address	The IP address of your gateway.

Network	The subnet mask of your gateway.
Default Gateway	Default gateway IP address.
Reserved Access IP	A reserved IP address to access in case your gateway IP is not available. Remember to set a similar network segment with the following address of your local PC.
Enable	A switch to enable the reserved IP address or not. ON(enabled), OFF(disabled)
Reserved Address	The reserved IP address for this gateway.
Reserved Netmask	The subnet mask of the reserved IP address.

Basically this info is from your local network service provider, and you can fill in four DNS servers.

Figure 7-1-2 DNS Interface

Table 7-1-2 Definition of DNS Settings

Options	Definition
DNS Servers	A list of DNS IP address. Basically this info is from your local network service provider.

DDNS Settings

You can enable or disable DDNS (dynamic domain name server).

Figure 7-2-1 DDNS Interface

Table 7-2-1 Definition of DDNS Settings

Options	Definition
DDNS	Enable/Disable DDNS(dynamic domain name server)
Type	Set the type of DDNS server.
Username	Your DDNS account's login name.
Password	Your DDNS account's password.
Your domain	The domain to which your web server will belong.

Toolkit

It is used to check network connectivity. Support Ping command on web GUI.

Figure 7-3-1 Network Connectivity Checking

8. Advanced

Asterisk API

When you make “Enable” switch to “ON”, this page is available.

Figure 8-1-1 API Interface

General	
Enable:	<input type="checkbox"/> ON <input type="checkbox"/>
Port:	5038
Manager	
Manager Name:	<input type="text" value="admin"/>
Manager secret:	<input type="text" value="admin"/>
Deny:	<input type="text" value="0.0.0.0/0.0.0.0"/>
Permit:	<input type="text" value="172.16.123.123/255.255.0.0&192.168.1.0"/>
Rights	
System:	read: <input checked="" type="checkbox"/> write: <input checked="" type="checkbox"/>
Call:	read: <input checked="" type="checkbox"/> write: <input checked="" type="checkbox"/>
Log:	read: <input checked="" type="checkbox"/> write: <input checked="" type="checkbox"/>
Verbose:	read: <input checked="" type="checkbox"/> write: <input checked="" type="checkbox"/>

Table 8-1-1 Definition of Asterisk API

Options	Definition
Port	Network port number
Manager Name	Name of the manager without space
Manager secret	Password for the manager. Characters: Allowed characters “-_.<>&0-9a-zA-Z”. Length:4-32 characters.
Deny	If you want to deny many hosts or networks, use char & as separator. Example: 0.0.0.0/0.0.0.0 or 192.168.1.0/255.255.255.0&10.0.0.0/255.0.0.0

Permit	If you want to permit many hosts or network, use char & as separator. Example: 0.0.0.0/0.0.0.0 or 192.168.1.0/255.255.255.0&10.0.0.0/255.0.0.0
System	General information about the system and ability to run system management commands, such as Shutdown, Restart, and Reload.
Call	Information about channels and ability to set information in a running channel.
Log	Logging information. Read-only. (Defined but not yet used.)
Verbose	Verbose information. Read-only. (Defined but not yet used.)
Command	Permission to run CLI commands. Write-only.
Agent	Information about queues and agents and ability to add queue members to a queue.
User	Permission to send and receive UserEvent.
Config	Ability to read and write configuration files.
DTMF	Receive DTMF events. Read-only.
Reporting	Ability to get information about the system.
CDR	Output of cdr, manager, if loaded. Read-only.
Dialplan	Receive NewExten and Varset events. Read-only.
Originate	Permission to originate new calls. Write-only.
All	Select all or deselect all.

Once you set like the above figure, the host 172.16.123.123/255.255.0.0 is allowed to access the gateway API. Please refer to the following figure to access the gateway API by putty.

172.16.123.123 is the gateway's IP, and 5038 is its API port.

Figure 8-1-2 Putty Access

```

172.16.123.123 - PuTTY
root@Openvox-Wireless-Gateway:~# telnet 172.16.123.123 5038
Asterisk Call Manager/1.1
action: login
username: admin
secret: admin

Response: Success
Message: Authentication accepted

Event: FullyBooted
Privilege: system,all
Status: Fully Booted

```

Asterisk CLI

In this page, you are allowed to run Asterisk commands.

Figure 8-2-1 Asterisk Command Interface

Output:

```

! Execute a shell command
agi dump html Dumps a list of AGI commands in HTML format
agi exec Add AGI command to a channel in Async AGI
agi set debug [on|off] Enable/Disable AGI debugging
agi show commands [topic] List AGI commands or specific help
aoc set debug enable cli debugging of AOC messages
cc cancel Kill a CC transaction
cc report status Reports CC stats
cdr show status Display the CDR status
cel show status Display the CEL status
channel originate Originate a call
channel redirect Redirect a call
channel request hangup Request a hangup on a given channel

```

Table 8-2-1 Definition of Asterisk API

Options	Definition
Command	Type your Asterisk CLI commands here to check or debug your gateway.

If you type “help” or “?” and execute it, the page will show you the executable commands.

Asterisk File Editor

On this page, you are allowed to edit and create configuration files.
Click the file to edit.

Figure 8-3-1 Configuration Files List

Configuration Files	
File Name	File Size
agents.conf	2136
alarmreceiver.conf	2227
asterisk.conf	247
cdr.conf	572
cdr_custom.conf	388
cdr_manager.conf	59
chan_extra.conf	56
codecs.conf	1655
dnsmgr.conf	245
dsp.conf	1520

1 2 3 4 5 ▶ 1 / 5 go

Click “New Configuration File” to create a new configuration file. After editing or creating, please reload Asterisk.

9. Logs

On the “Log Settings” page, you should set the related logs on to scan the responding logs page. For example, set “System Logs” on like the following, then you can turn to “System” page for system logs, otherwise, system logs is unavailable. And the same with other log pages.

Figure 9-1-1 System Logs Control

System Logs	
System Logs:	<input type="checkbox"/> ON <input type="checkbox"/>
Auto clean:	<input type="checkbox"/> ON <input type="checkbox"/> maxsize : 1MB ▼

Asterisk Logs	
Verbose:	<input type="checkbox"/> ON <input type="checkbox"/>
Notice:	<input type="checkbox"/> ON <input type="checkbox"/>
Warning:	<input type="checkbox"/> ON <input type="checkbox"/>
Debug:	<input type="checkbox"/> ON <input type="checkbox"/>
Error:	<input type="checkbox"/> ON <input type="checkbox"/>
DTMF:	<input type="checkbox"/> ON <input type="checkbox"/>
Auto clean:	<input type="checkbox"/> ON <input type="checkbox"/> maxsize : 100KB ▼

SIP Logs	
SIP Logs:	<input type="checkbox"/> ON <input type="checkbox"/>
Auto clean:	<input type="checkbox"/> ON <input type="checkbox"/> maxsize : 100KB ▼

AT Commands Logs	
AT Commands Logs:	<input type="checkbox"/> ON <input type="checkbox"/>
Auto clean:	<input type="checkbox"/> ON <input type="checkbox"/> maxsize : 100KB ▼

Call Detail Record	
Call Detail Record:	<input type="checkbox"/> ON <input type="checkbox"/>
Append IMEI:	<input type="checkbox"/> ON <input type="checkbox"/>
Auto clean:	<input type="checkbox"/> ON <input type="checkbox"/> maxsize : 20MB ▼

Figure 9-1-2 System Logs Output

```

System Logs
[1970/01/01 00:00:07] Auto restore configuration files
[1970/01/01 08:00:41] Power on
[1970/01/01 08:00:25] Power on
[1970/01/01 08:00:25] Power on
[1970/01/01 00:00:03] Auto restore configuration files
[1970/01/01 08:00:26] Power on
[1970/01/01 08:09:19] Restore configuration files
[1970/01/01 08:09:19] Power off
[1970/01/01 00:00:03] Auto restore configuration files
[1970/01/01 08:00:25] Power on
[1970/01/01 08:00:26] Power on
[1970/01/01 08:15:51] Restore configuration files
[1970/01/01 08:15:51] Power off
[1970/01/01 00:00:03] Auto restore configuration files
[1970/01/01 08:00:28] Power on
[1970/01/01 08:00:27] Power on
[2014/12/15 14:00:30] Power off
[1970/01/01 00:00:05] Auto update configuration files, remain a few files.
    
```

You can scan your CDR easily on web GUI, and also you can delete, clean up or export your CDR information.

Figure 9-1-4 CDR Output

Caller ID	Callee ID	From	To	Start Time	Duration	Result
<input type="text"/>	<input type="text"/>	<input type="text"/>	<input type="text"/>	from <input type="text"/> to <input type="text"/>	from <input type="text"/> to <input type="text"/>	All <input type="text"/>
Filter Clean Filter						
Total Records: 2						
Caller ID	Callee ID	From	To	Start Time	Duration	Result
<input type="checkbox"/> 301	<input type="text"/>	301	gsm-1.1(IMEI:865328021110274)	2015-04-17 18:17:43	00:00:00	NO ANSWER
<input type="checkbox"/> 301	<input type="text"/>	301	gsm-1.1(IMEI:865328021110274)	2015-04-17 18:15:45	00:00:08	ANSWERED

Recently we have made our LOGS display richer, you can see your GSM Outbound of every port clearly.

Figure 9-1-5 Time Patterns that will use this Route

GSM Outbound									
Port	All Calls	All Durations	Answered	Canceled	Busy	No Answer	No Dialtone	No Carrier	Other
gsm-1.1	2	8	1	0	0	0	0	0	1
gsm-1.2	0	0	0	0	0	0	0	0	0
gsm-1.3	0	0	0	0	0	0	0	0	0
gsm-1.4	0	0	0	0	0	0	0	0	0
Total	2	8	1	0	0	0	0	0	1

Table 9-1-1 Definition of Logs

Options	Definition
System Logs:	Whether enable or disable system log.
Auto clean: (System Logs)	switch on : when the size of log file reaches the max size, the system will cut a half of the file. New logs will be retained. switch off : logs will remain, and the file size will increase gradually. default on, max size=1MB.
Verbose:	Asterisk console verbose message switch.
Notice:	Asterisk console notice message switch.
Warning:	Asterisk console warning message switch.
Debug:	Asterisk console debug message switch.
Error:	Asterisk console error message switch.
DTMF:	Asterisk console DTMF info switch.
Auto clean: (asterisk logs)	switch on : when the size of log file reaches the max size, the system will cut a half of the file. New logs will be retained. switch off : logs will remain, and the file size will increase gradually. default on, max size=100KB.
SIP Logs:	Whether enable or disable SIP log.
Auto clean: (SIP logs)	switch on : when the size of log file reaches the max size, the system will cut a half of the file. New logs will be retained. switch off : logs will remain, and the file size will increase gradually. default on, maxsize=100KB.
Debug AT Commands Logs:	Displaying GSM module AT messages.

Auto clean: (AT logs)	switch on : when the size of log file reaches the max size, the system will cut a half of the file. New logs will be retained. switch off : logs will remain, and the file size will increase gradually. default on, max size=100KB.
Call Detail Record:	Displaying Call Detail Records for each channel.
Auto clean: (CDR logs)	switch on : when the size of log file reaches the max size, the system will cut a half of the file. New logs will be retained. switch off : logs will remain, and the file size will increase gradually. default on, max size=20MB.

Appendix Feature List

- Wireless port: GSM 850/900/1800/1900MHz
- Storage temperature: -20~70°C
- Operating temperature: 0~40°C
- Operating humidity: 10%~90%
- Power supply specifications: 12V DC/2.33A
- Maximum power: 18W

GSM

- Support Volume adjustment
- Support Gain adjustment
- Support CLID display & hide (need operators support)
- Support IMEI number automatically modify, avoid blocking
- Support PIN identification
- Support GSM frequency range: 850/900/1800/1900MHz
- Support Band binding
- Support SMS bulk transceiver, messages sent to email and SMS automatically resent
- Support USSD transceiver
- Support call transfer
- Support open API interface (AMI)

SIP Features

- Support add, modify & delete SIP trunk
- Support different SIP trunks combined into one SIP trunk Group
- Support SIP registration with domain
- Support multiple SIP registrations: Anonymous, Endpoint registers with this gateway, This gateway registers with the endpoint
- Support protocols: SIP, IAX (easily expand other protocols that Asterisk supports), TCP, UDP, RTP, TELNET, HTTP, SMTP, POP3

Routing and Number Conversion

- Support routing before number changed
- Support routing after number changed
- Support GSM→IP routing
- Support IP→GSM routing
- Support add, modify & delete routing

- Support unlimited routing rules
- Flexible routing settings

Business Control

- Permit and prohibit certain calls
- Extensible automatic callback
- Extensible speed dial
- Support customizable IVR, DISA and other applications

System Features

- Simple and convenient configuration via Web GUI
- Signal strength indicator, LED status indicator
- Support NTP time synchronization and client time synchronization
- Support DTMF: RFC2833, In-band, Info
- Working mode: stand-alone, Master, slave.
Each Board integrated independent Asterisk system would make it easier for independent operation, improve stability
- Support SSH access for background management, Asterisk CLI command operation
- Support AT command interface
- GSM ports group management
- Support PDD (Post Dialing Delay) display, ACD (Average Call Duration) display, ASR (Answer-Seizure Ratio) display and BER (Bit Error Rate) display
- Support configuration file backup and upload
- Support for custom scripts, dialplans
- Support codecs: G.711A, G.711U, G.729, G.722, G.723, G.726, GSM

Network Features

- Support DDNS
- 2*RJ45 Network port
 - ① ETH1: access Board 1 only, provide proxy access to other boards with different port numbers which can avoid IP conflict
 - ② ETH2: access different Boards with different IP addresses
- Network type: Static IP, Dynamic, PPPoE
- Support modify username and password for web login
- Support ping & traceroute command on the web

Operation Maintenance

- Support SMS remotely controlling gateway
- Support Echo cancellation, Jitter buffer
- Support gateway boards and SIM hot plug
- Reboot settings (According to the running time, specific time)
- Update Firmware: HTTP
- Support multiple detailed LOG output
- Support Restore the factory settings
- One Year Warranty

Application diagrams

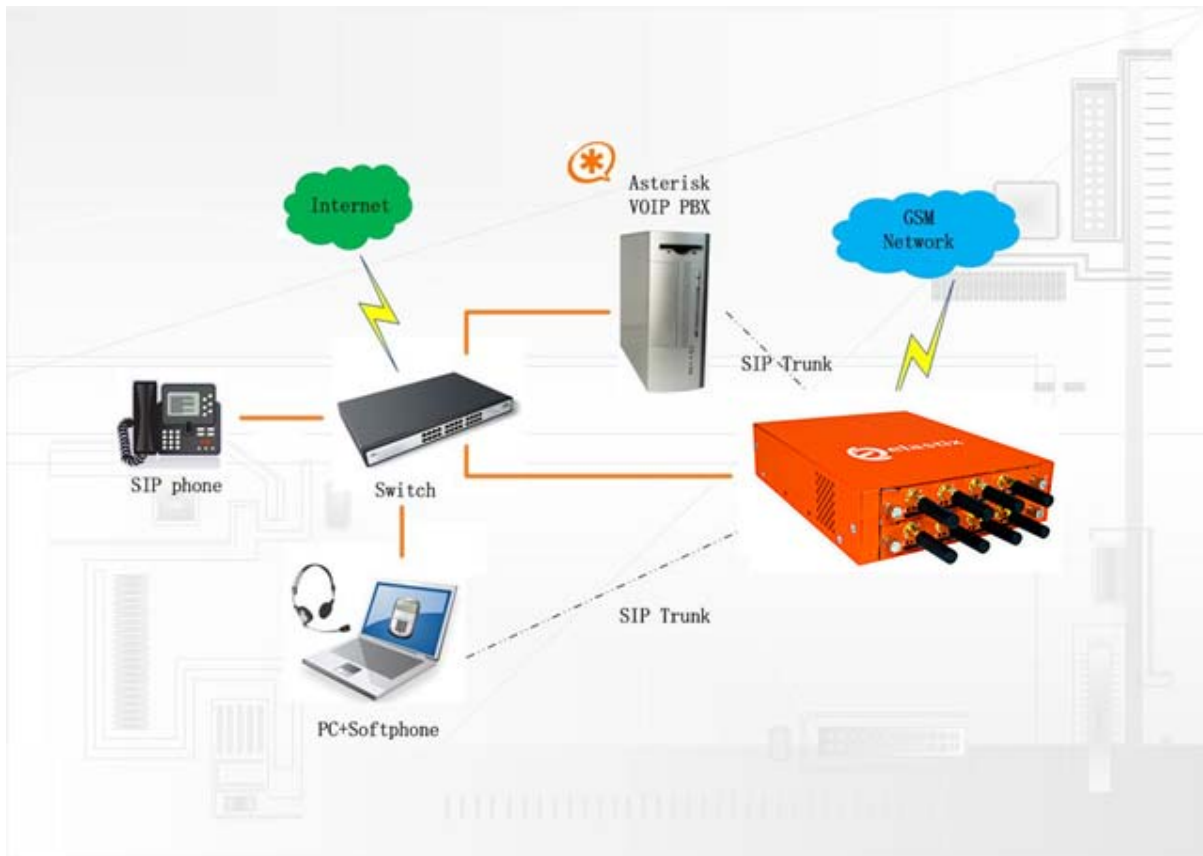

Thank You for Choosing Elastix Products!