

Joto AutoClam Press Manual

Model No.: E-HP-JAR-1515 / E-HP-JAR-1620

OPERATOR'S MANUAL



JOTOTM
Bringing images to lifeTM

Safety Instructions

For Use By Qualified Personnel Only

When using your Heat Press, basic precautions should always be followed, including the following:

Read all instructions.

Use heat press only for its intended use.

Keep the heat press dry at all times. Do not get the heat press wet to reduce the risk of electric shock. Do not store heat press in a wet or damp area.

Never pull cord to disconnect the power, grasp plug and pull to disconnect from power outlet.

Protect the power cord by keeping it away from hot surfaces. Do not allow objects to sit on top of the cord. This could cause damage to the cord and could become a fire hazard risk.

Do not operate heat press with a damaged cord or if the equipment has been damaged. Do not disassemble or attempt to repair the heat press to prevent risks to injury. Call or take it to a qualified service person for examination and repair. Incorrect assembly or repair could increase the risk of fire, electric shock, or injury to persons when the equipment is used.

Supervision is necessary for any heat press being used by or near children. Do not leave equipment unattended while connected.

Metal parts on the press can become hot. Burns may occur when touching hot metal parts. Take caution when using the heat press

To reduce the likelihood of circuit overload, It is recommended to use a dedicated circuit if possible.

Care should be taken to arrange the cord so that it cannot be pulled or tripped over.

To reduce the likelihood of circuit overload, do not operate other high voltage equipment on the same circuit.

If an extension cord is necessary, then a 20 amperage rated cord should be used. Cords rated for less amperage may overheat. Care should be taken to arrange the cord so that it cannot be pulled or tripped over.

Note: This heat press should not be set to exceed 200C. Setting the press temperature to above 200C may cause a fire hazard.

Be careful of the Auto Release feature. Press handle can injure body parts when autoreleasing. Stand clear of auto-release path.

Congratulations on your purchase of a Joto AutoClam Heat Press! In order to work professionally with the machine and start production, please make sure you read this manual carefully. Reproduction of this manual requires written consent from Joto. Errors and amendments of technical details excepted, all rights reserved. Joto is not liable for any direct or indirect damages caused by the use of this product.

Table of Contents

Safety.....	2
Introduction	3
Machine Parts Diagram	4
Setting Up Your Heat Press	5
Operating Instructions	6
Heat Press Overview	7
Maintenance	8
Joto Sublimation/Transfer Vinyl Guide	8
Circuit Diagram.....	10
Expanded View	11
Contact	12

Machine Parts Diagram

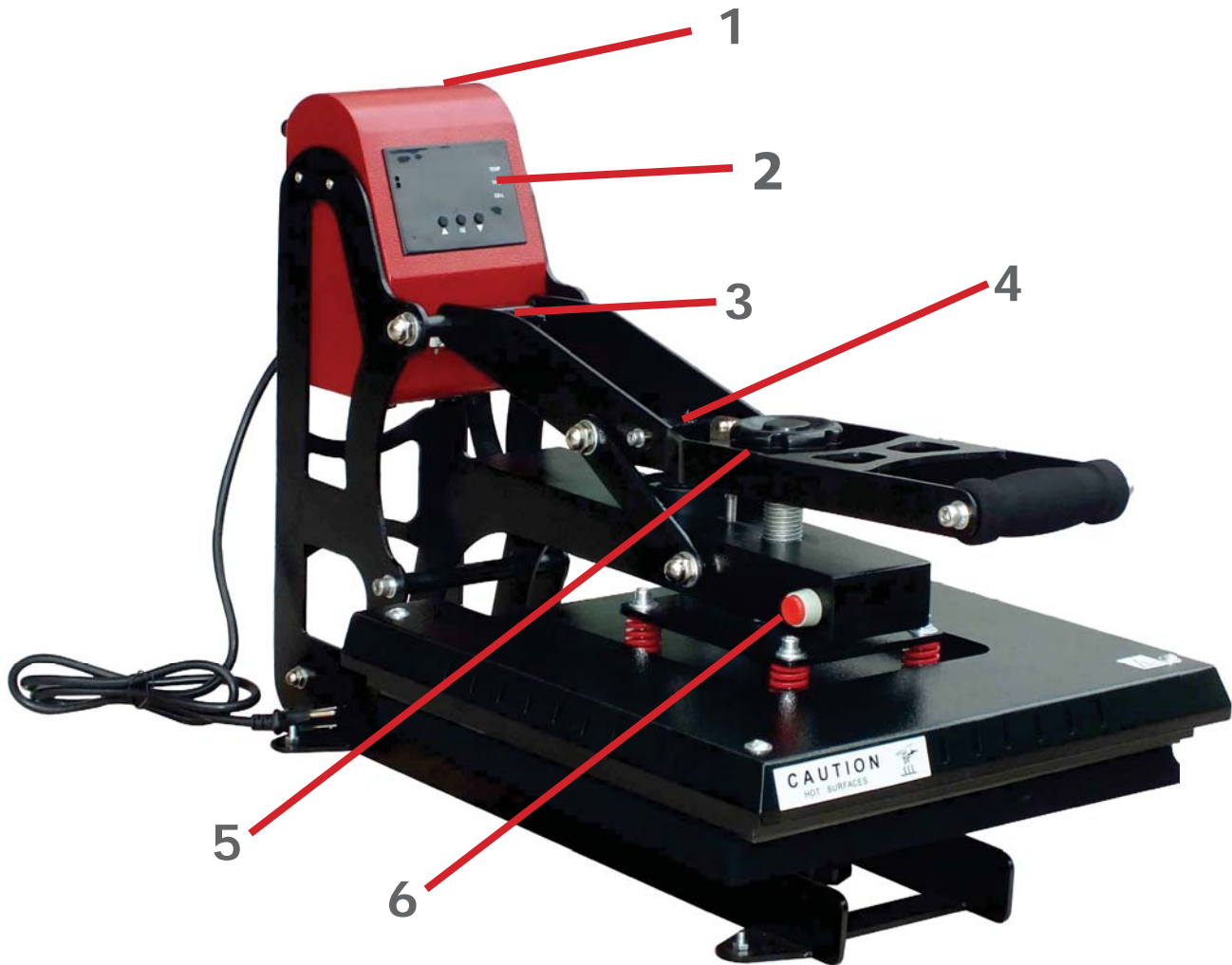

- 1.) Electrical Case
- 2.) GY-06 Digital Controller
- 3.) Limit Switch
- 4.) Electromagnetic Suck Plate
- 5.) Pressure Adjust Knob
- 6.) Emergency Stop Button
- 7.) Power Switch
- 8.) Handle Gear for Exchange Under Plate

Setting Up Your Heat Press

Turning On Your Heat Press

Turn the Main Power Switch on. The Main Power Switch is at the right side of the heat press.

Current temperature, set temperature, current time, set time will display.



How to Read The Display

- 1.) Right side PV value = Current Temperature
- 2.) Left side PV value = Current Time
- 3.) Right side SV value = Set Press Temperature
- 4.) Left side SV value = Set Press Time



Setting Press Temperature

Press OK to start. Use the up and down arrows to choose to display in °F or °C.
°F stands for Fahrenheit
°C stands for Celsius

Once selection is made, press ok to save

Green set temperature value will flash.
Use the up and down arrows to set press temperature value. Press ok to save



Note: Setting the press temperature to above 200C may cause a fire hazard.

Setting Press Time

Green Set Time Value will flash
Use the up and down arrows to change the value.

Press ok to save the value.

Wait until the current temperature is the same as the set temperature before using. The press will beep once set temperature is reached. Close and open the press to stop the beeping



Operating Instructions

Pressing a T-shirt

- 1.) Turn on the Main Power Switch
- 2.) Set the appropriate Press Temperature, and Time as per your transfer vinyl or sublimation instructions.
- 3.) Place your t-shirt on the heat press.
- 5.) Set the pressure. Press the blank shirt to ensure there is adequate pressure before placing transfer materials on top of the shirt.
Adjust the pressure knob accordingly
- 6.) Wait until current temperature is the same as the set temperature. Once the press has reached set temperature, place transfer material on the shirt. For Sublimation, place the paper with the image face down. For cuttable transfer vinyl, place the matte side with the transparent carrier backing facing the heat platen. If unsure, please refer to the instructions you received with your transfer materials.
- 7.) Once Press is closed the current time value will start counting down. Once the timer reaches the last 2 seconds before reaching 0, it will start to beep to warn you. It is recommended to stand clear of the press and let the auto-open feature work without obstruction. Once time reaches zero, the press will open.

Note: Once the press is closed, it cannot be opened manually until the timer reaches zero. In an emergency, you may press the red emergency stop button to force open the press. When pressing the red emergency stop button, the press will open immediately without warning. Keep hands on the heat press handle at all times during and after pressing the emergency stop button. Not securing the handle with your hands may cause injury.

- 8.) For most sublimation and transfer vinyl, the peel is hot. If unsure, refer to the instructions that came with your transfer materials.

Heat Press Overview



Technical Specs

Model No.:	E-HP-JAR-1515	E-HP-JAR-1620
Machine Type:	Auto Release Clam Shell	Auto Release Clam Shell
Machine Size:	748mm x 480mm x410mm	748mm x 480mm x410mm
Heat platen Size:	15" X 15"	16" X 20"
Under Plate:	Exchangeable	Exchangeable
Controller	GY-06 Digital Controller	GY-06 Digital Controller
Printable Materials:	Up to 5mm Thickness	Up to 5mm Thickness
Voltage:	120V/220V	120V/220V
Power:	1750W/1800W	1750/1800W
Time Range:	0-999 Seconds	0-999 Seconds
Maximum Temp:	491°F (225°C)	491°F (225°C)
Packing Size:	540mm x 880mm x 570mm	540mm x 880mm x 570mm
Gross Weight:	60kg	60kg

Note: This heat press should not be set to exceed 200C. Setting the press temperature to above 200C may cause a fire hazard.

Maintenance

General Maintenance

Please switch off the machine and unplug the power cord when the machine is not in use.

To protect the heat platen, do not allow any hard surface objects to be in direct contact with the platen. This includes zippers, buttons, metal sublimation items. When pressing these items, place a protective sheet between the platen and the objects.

The heat platen will cool down to the room temperature, if heat press stays un-use for more than 30 minutes.

The heat-releasing fan will automatically starts when the temperature of heat platen reaches 80 degree C (176 degree F). It helps to reduce the temperature of electrical parts and prolong the service life of them.

Please add the lubrication oil regularly on the joints. to prolong the life of your heat press. The frequency will depend on how often you use your machine.

Note: This heatpress should not be set to exceed 200C. Setting the press temperature to above 200C may cause a fire hazard.

Heat Pressing Guide

MultiCut Ultra Matte

Temperature: 320F
Time: 20 seconds
Peel: Hot

MultiCut Flock Premium

Temperature: 320F
Time: 20 seconds
Peel: Hot

MultiCut Nylon

Temperature: 345F
1st Press Time: 3 seconds
2nd Press Time: 10 seconds

MultiCut Premium

Temperature: 320F
Time: 10 seconds
Peel: Hot

MultiCut Lustre

Temperature: 310-330F
Time: 15-20 seconds
Peel: Hot to Cold

MultiCut Style

Temperature: 310-330F
Time: 15-20 seconds
Peel: Hot to Cold

Heat Pressing Guide (continued)

Sublimation Items

Sublimatable Ceramic Tiles

Temperature: 400F
Time: 360-420 seconds
Peel: Hot
Method: Substrate face down
Image face up

Porcelain Ornaments

Temperature: 400F
Time: 180-240 seconds
Peel: Hot
Method: Substrate face down
Image face up

MousePads/CanCoolers

Temperature: 400F
Time: 35-45 seconds
Peel: Hot
Method: Substrate face up
Image face down

Coasters/Fabric Puzzles

Temperature: 400F
Time: 35-45 seconds
Peel: Hot
Method: Substrate face up
Image face down

Phone cover inserts

Temperature: 360F
Time: 120 seconds
Peel: Hot
Method: Substrate face down
Image face up

Unisub Metals

Temperature: 400F
Time: 60 seconds
Peel: Hot
Method: Substrate face up
Image face down

Unisub Plastics

Temperature: 400F
Time: 75-80 seconds
Peel: Hot
Method: Substrate face up
Image face down

Unisub Wood

Temperature: 400F
Time: 75-80 seconds
Peel: Hot
Method: Substrate face up
Image face down

Unisub Plaques

Temperature: 400F
Time: 75-80 seconds
Peel: Hot
Method: Substrate face up
Image face down

Circuit Diagram

GY-06 Digital Control 110V (220V)

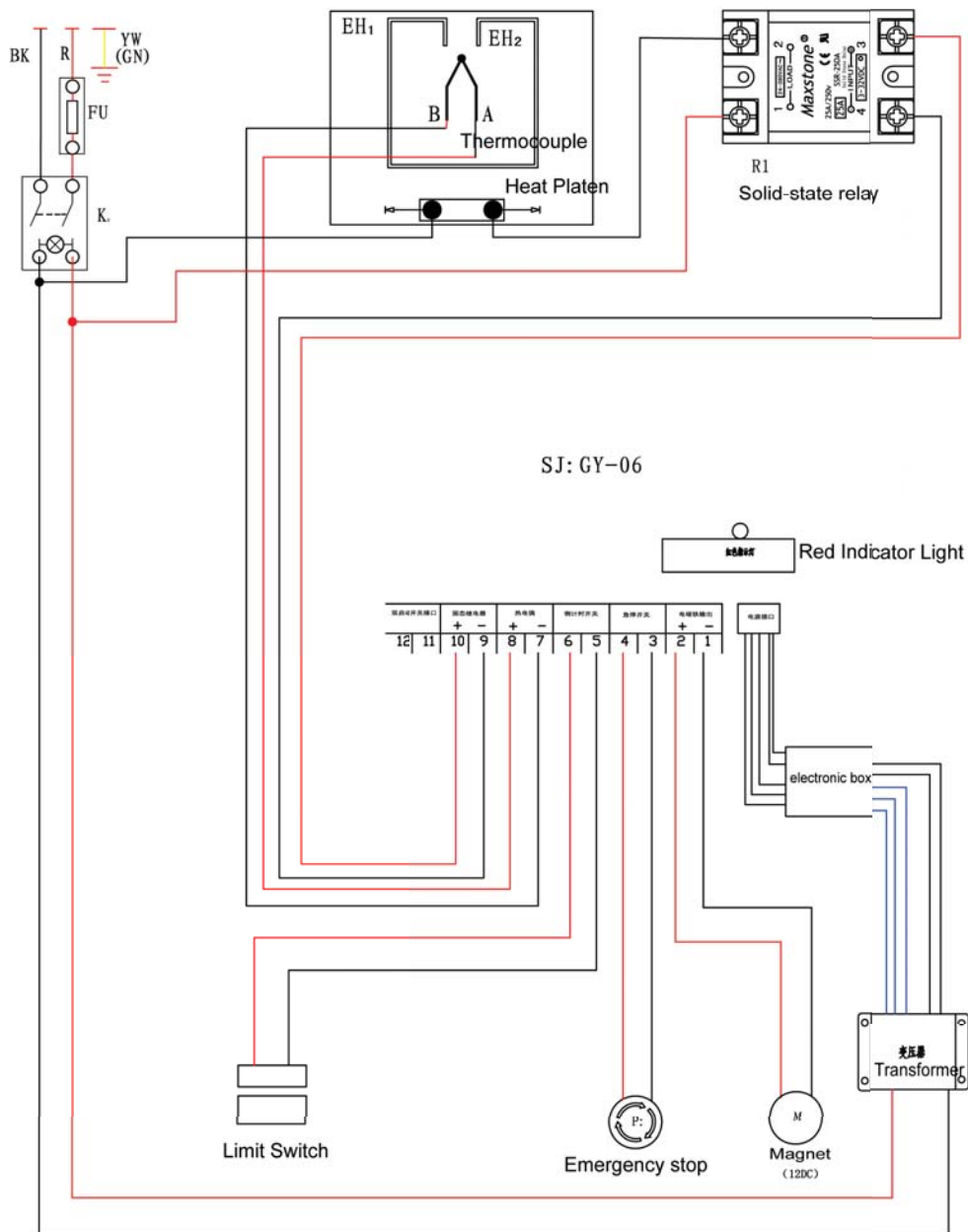

Expanded Diagram

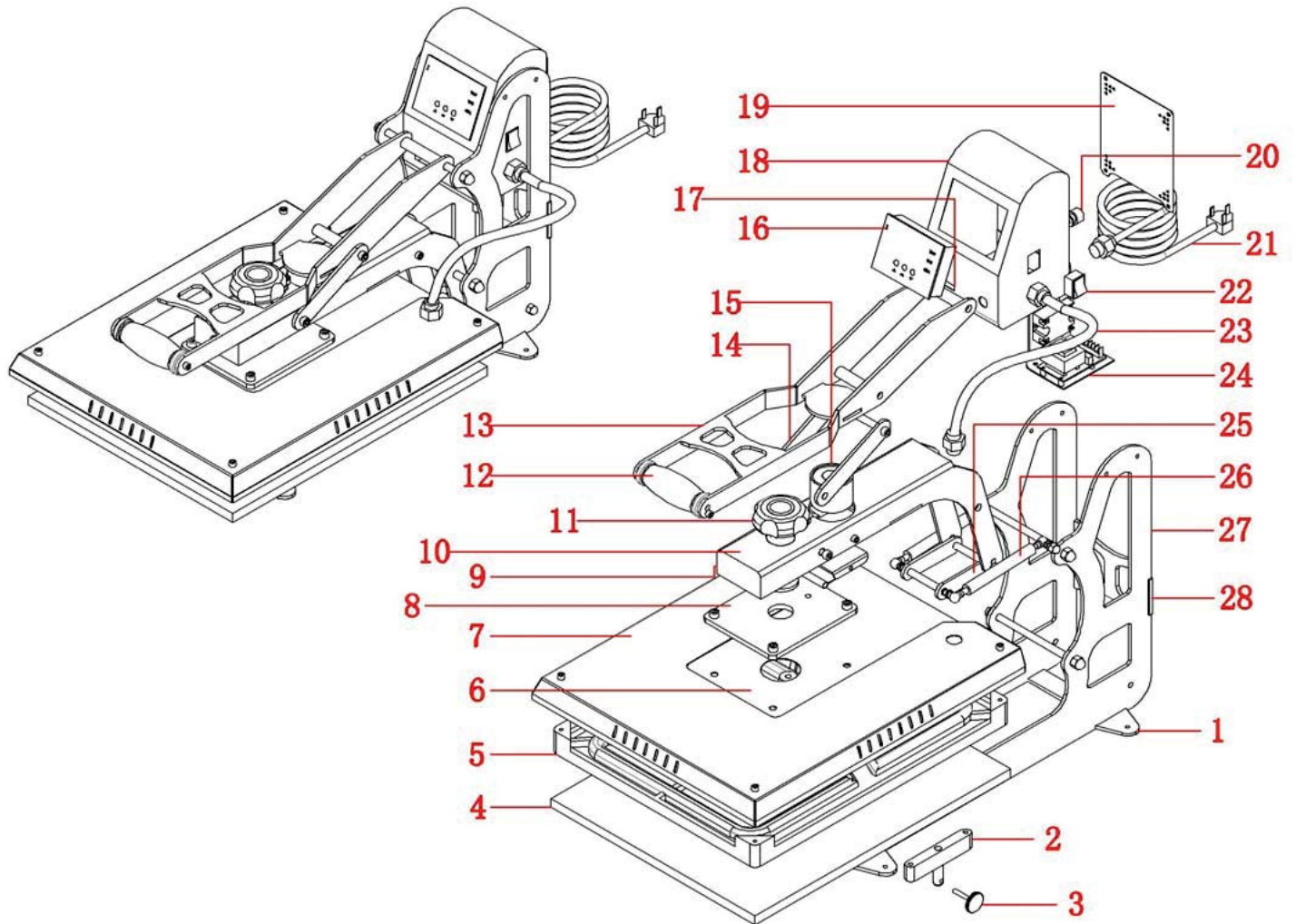

- | | | |
|--|-------------------------------|-------------------------------|
| 1.) Machine Foot | 11.) Pressure Adjust Knob | 21.) Power Cord |
| 2.) Under Plate Fitting | 12.) Handle Bar Grip | 22.) Power Switch |
| 3.) Handle Gear for Exchange Under Plate | 13.) Handle Frame | 23.) Serpentine |
| 4.) Under Plate | 14.) Handle Connect Piece | 24.) Electrical Parts Bracket |
| 5.) Heat Platen | 15.) Electromagnet | 25.) Sprint Connect Piece |
| 6.) Heat Platen Metal Cover | 16.) GY-06 Digital Controller | 26.) Gas Spring |
| 7.) Anti-scald Protect Cover | 17.) Limit Switch | 27.) Machine Frame |
| 8.) Heat Platen Adaptor Plate | 18.) Electronic Case | 28.) Welded Plate |
| 9.) Emergency Stop Button | 19.) Back Cover | |
| 10.) Davit Arm | 20.) Fuse Holder | |

JOTOTM

A red swoosh underline that starts under the 'J' and extends to the right, ending under the 'O'.

Bringing images to lifeTM

www.jotopaper.com

Tel: 1-800-565-5686

Fax: 1-800-565-55622

Coquitlam, BC | Mississauga, ON

Blaine, WA | Las Vegas, NV | Nashville TN | Akron, OH