

USER'S MANUAL

# Phoenix 98835 MOTORIZED TREADMILL

MODEL NUMBER: 98835



USER WEIGHT LIMITATION: **275lbs. (125kgs)**

TOLL FREE CUSTOMER SERVICE NUMBER: 1.888.535.8637

SERIAL NUMBER (found on frame):



## PRECAUTIONS

### Precautions:

**WARNING:** To reduce the risk of burns, fire, electric shock, or injury to persons, read the following important precautions and information before operating the treadmill. It is the responsibility of the owner to ensure that all users of this treadmill are adequately informed of all warnings and precautions.

- Use the treadmill only as described in this manual.
- Place on a level surface, with 2 meters (6 feet) of clearance behind it. Do not place the treadmill on any surface that blocks air openings. To protect the floor or carpet from damage, place a mat under the treadmill.
- When choosing a location for the treadmill make sure that the location and position permit access to a plug.
- Keep the treadmill indoors, away from moisture and dust. Do not put the treadmill in a garage or covered patio, or near water.
- Do not operate the treadmill where aerosol products are used or where oxygen is being administered.
- Keep children under the age of 12 and pets away from the treadmill at all times.
- The treadmill should not be used by persons weighing more than 275lbs. (125kgs)
- Never allow more than one person on the treadmill at a time. Wear appropriate exercise clothing when using the treadmill. Do not wear loose clothing that could become caught in the treadmill. Athletic support clothes are recommended for both men and women. Always wear athletic shoes. Never use the treadmill with bare feet, wearing only stockings, or in sandals.
- When connecting the power cord, plug the power cord into a grounded circuit. No other appliance should be on the same circuit.
- Always straddle the belt and allow it to start moving before stepping onto the belt.
- Always examine your treadmill before using to ensure all parts are in working order.
- Allow the belt to fully stop before dismounting.
- Never insert any object or body parts into any opening.
- Follow the safety information in regards to plugging in your treadmill.
- Keep the power cord away from the incline wheels and do not run the power cord underneath your treadmill. Do not operate the treadmill with a damaged or frayed power cord.
- Always unplug the treadmill before cleaning and/or servicing. Service to your treadmill should only be performed by an authorized service representative, unless authorized and/or instructed by the manufacturer. Failure to follow these instructions will void the treadmill warranty.
- Never leave the treadmill unattended while it is running.

## POWER REQUIREMENTS

### **Power Requirements:**

IMPROPER CONNECTION OF THE EQUIPMENT GROUNDING CONNECTOR CAN RESULT IN A RISK OF AN ELECTRIC SHOCK. CHECK WITH A QUALIFIED ELECTRICIAN OR SERVICE MAN IF YOU ARE IN DOUBT AS TO WHETHER THE PRODUCT IS PROPERLY GROUNDED. DO NOT MODIFY THE PLUG PROVIDED WITH THE PRODUCT, IF IT WILL NOT FIT THE OUTLET; HAVE A PROPER OUTLET INSTALLED BY A QUALIFIED ELECTRICIAN.

This treadmill can be seriously damaged by sudden voltage changes in your home's electrical power. Voltage spikes, surges and noise interference can result from weather conditions or from other appliances being turned on or off. To reduce the possibility of treadmill damage, always use a surge protector (not included) with your treadmill.

This treadmill must be grounded to reduce the risk of electrical shock. Grounding provides a path of least resistance for electric current, should the treadmill malfunction. This treadmill comes with an electrical cord having an equipment-grounding conductor and a grounding plug. Always plug the power cord into a surge protector, and plug the surge protector into an appropriate outlet that is properly installed and grounded in accordance with all local codes and ordinances.

## PREASSEMBLY

### Open the boxes:

You are now ready to open the boxes of your new equipment. Make sure to inventory all of the parts that are included in the boxes. Check the Hardware Comparison Chart for a full count of the number of parts included for this product to be assembled properly. If you are missing any parts or have any assembly questions call the manufacturer.

### Gather your tools:

Before starting the assembly of your unit, make sure that you have gathered all the necessary tools you may require to assemble the unit properly. Having all of the necessary equipment at hand will save time and make the assembly quick and hassle-free.

### Clear your work area:

Make sure that you have cleared away a large enough space to properly assemble the unit. Make sure the space is free from anything that may cause injury during assembly. After the unit is fully assembled, make sure there is a comfortable amount of free area around the unit for unobstructed operation.

### Invite a friend:

Some of the assembly steps may require heavy lifting. It is recommended that you obtain the assistance of another person when assembling this product.

### User Weight Limitation:

Please note that there is a weight limitation for this product. **If you weigh more than 275lbs (125kgs) it is not recommended that you use this product. Serious injury may occur if the user's weight exceeds the limit shown here.** This product is not intended to support users whose weight exceeds this limit.

**HARDWARE COMPARISON CHART**

**Hardware chart:**

For your convenience, we have identified the hardware used in the assembly of this product. This chart is provided to help you identify those items that may be unfamiliar to you.

NO.	DESCRIPTION	QTY.
70	M4 x 15mm Screw	17
76	M6 X 15mm Screw	2
77	M8 x 18mm Allen Bolt	6
78	M8 x 50mm Allen Bolt	2
88	Washer	6
100	M8 x 30mm Screw	2
103	M4 x 19mm Screw	2
104	8mm Spring Washer	4
A	Allen Key Tool	1
B	Screw Driver Tool	1
C	Allen Wrench Tool	1

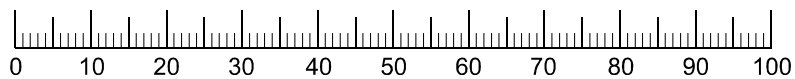
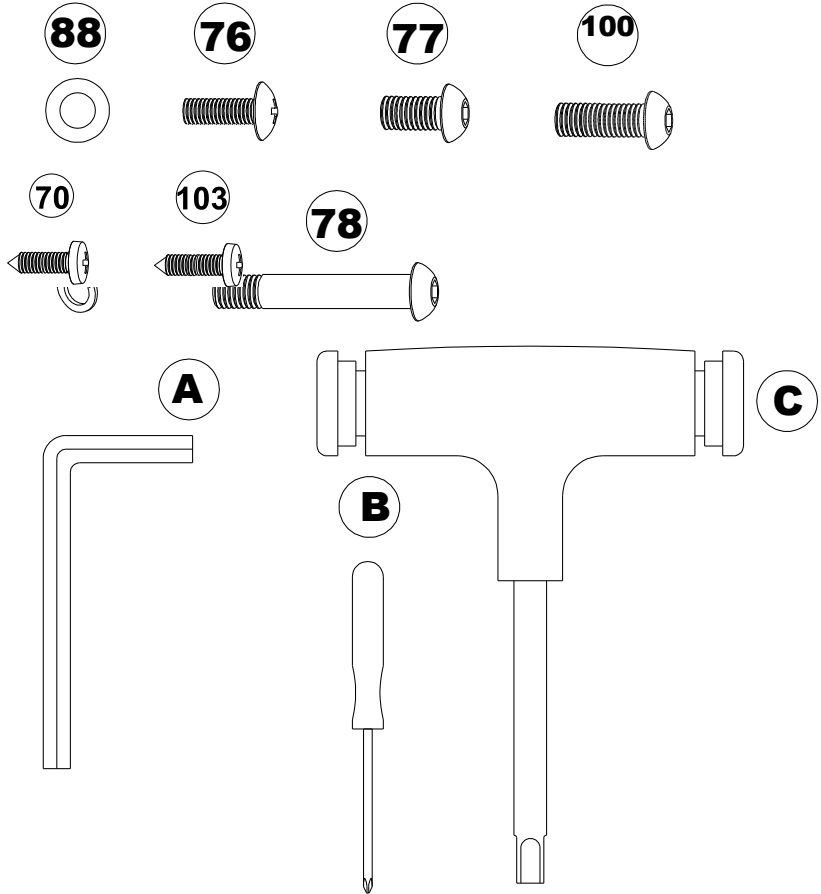

MILIMETERS

## 089 MOTORIZED TREADMILL

## PARTS LIST

NO.	DESCRIPTION	QTY.	ORDER NO.	NO.	DESCRIPTION	QTY.	ORDER NO.
1	Computer Insert	1	089-01	28	Fold Up Support Bushing	2	089-28
2	Console Housing - Upper	1	089-02	29	Fold Up Support Insert	1	089-29
3	Console Housing - Bottom	1	089-03	30	Nut	1	089-30
4	Safety Key	1	089-04	31	Spacer	1	089-31
5	EKG Pulse Sensor	2	089-05	32	Foot Up Locker	1	089-32
6	Front Handlebar	1	089-06	33	Base Frame Rubber Cushion - Rear	2	089-33
7	Handlebar Cover - Left #1	1	089-07	34	Transportation Wheel	3	089-34
8	Handlebar Cover - Left #2	1	089-08	35	Console Plate	1	089-35
9	Handlebar Cover - Right #2	1	089-09	36	Motor Hood	1	089-36
10	Handlebar Cover - Right #1	1	089-10	37	Side Rail	2	089-37
11	Handlebar Grip	2	089-11	38	Deck End Cap - Right	1	089-38
12	Handlebar End Cap	2	089-12	39	Deck End Cap - Left	1	089-39
13	EKG Pulse Wire	2	089-13	40	Motor Bottom Cover	1	089-40
14	Motion Control Sensor	2	089-14	41	Motor Hood Side Cover - Right	1	089-41
15	Upright - Left	1	089-15	42	Motor Hood Side Cover - Left	1	089-42
16	Upright - Right	1	089-16	43	Front Roller	1	089-43
17	Upright Base Cover - Left #1	1	089-17	44	Rear Roller	1	089-44
18	Upright Base Cover - Left #2	1	089-18	45	Running Belt	1	089-45
19	Upright Base Cover - Right #2	1	089-19	46	Motor Holder	1	089-46
20	Upright Base Cover - Right #1	1	089-20	47	Driving DC Motor	1	089-47
21	Upright Base Cover - Upper	2	089-21	48	Driving Belt	1	089-48
22	Base Frame	1	089-22	49	Elevation Control Board	1	089-49
23	Fold Up Support	1	089-23	50	Motor Control Board	1	089-50
24	Power Plate	1	089-24	51	Running Deck	1	089-51
25	Power Plate Plastic Frame	1	089-25	52	Side Rail Guider	6	089-52
26	Base Frame Tube End Cap - Front	2	089-26	53	Running Deck Rubber Cushion	8	089-53
27	Base Frame Tube End Cap - Rear	2	089-27	54	Elevation Support Frame	1	089-54

## 089 MOTORIZED TREADMILL

## PARTS LIST

NO.	DESCRIPTION	QTY.	ORDER NO.	NO.	DESCRIPTION	QTY.	ORDER NO.
55	Elevation Support Frame End Cap #1	2	089-55	82	M10 x 68mm Allen Bolt	1	089-82
56	Plastic Clamp - Upper	2	089-56	83	Pivot Shaft	1	089-83
57	Plastic Clamp - Bottom	2	089-57	84	Deck Wheel Bolt	2	089-84
58	Bracket	2	089-58	85	Fold Up Stopper	1	089-85
59	Elevation Support Frame End Cap #2	2	089-59	86	Elevation Support Frame Fixing Bolt	2	089-86
60	Deck Frame	1	089-60	87	6mm Washer	3	089-87
61	Elevation Motor	1	089-61	88	Washer	12	089-88
62	Elevation Motor Gear Sleeve	1	089-62	89	10mm Washer	2	089-89
63	Gas Shock	1	089-63	90	M8 Nylon Nut	8	089-90
64	Deck Wheel	2	089-64	91	M10 Nylon Nut	2	089-91
65	PU Cushion	1	089-65	92	M10 Nut	1	089-92
66	20 x 40mm Washer	2	089-66	93	N/A		089-93
67	Driving Belt Adjustment bolt	1	089-67	94	Gas Shock Fixing Spacer	2	089-94
68	M16 Nylon Nut	1	089-68	95	Base Frame Rubber Cushion - Front	4	089-95
69	Deck Rubber Cushion Bolt	8	089-69	96	Elevation Control Board Fixing Insert	6	089-96
70	M4 x 15mm Screw	29	089-70	97	Handlebar	1	089-97
71	Console Housing Screw	10	089-71	98	Running Deck Cross Brace	1	089-98
72	Plastic Fixing Insert	6	089-72	99	Running Deck Cross Brace Foam	1	089-99
73	Side Rail Guider Screw	12	089-73	100	M8 x 30mm Screw	4	089-100
74	Rubber Cushion Screw	4	089-74	101	SPRING	1	089-101
75	Roller Adjustment Bolt	3	089-75	102	TRANSPORTATION WHEEL BRACKET	1	089-102
76	M6 x 15mm Screw	4	089-76	103	M4 x 19mm Screw	2	089-103
77	M8 x 18 Allen Bolt	6	089-77	104	8mm Spring Washer	6	089-104
78	M10 x 50mm Allen Bolt	4	089-78				
79	Transportation Wheel Bolt	3	089-79				
80	Elevation Motor Fixing Bolt	1	089-80				
81	M10 x 63mm Bolt	1	089-81				

PARTS DIAGRAM

A MAJORITY OF THE PARTS SHOWN HERE HAVE BEEN PREASSEMBLED AT THE FACTORY.

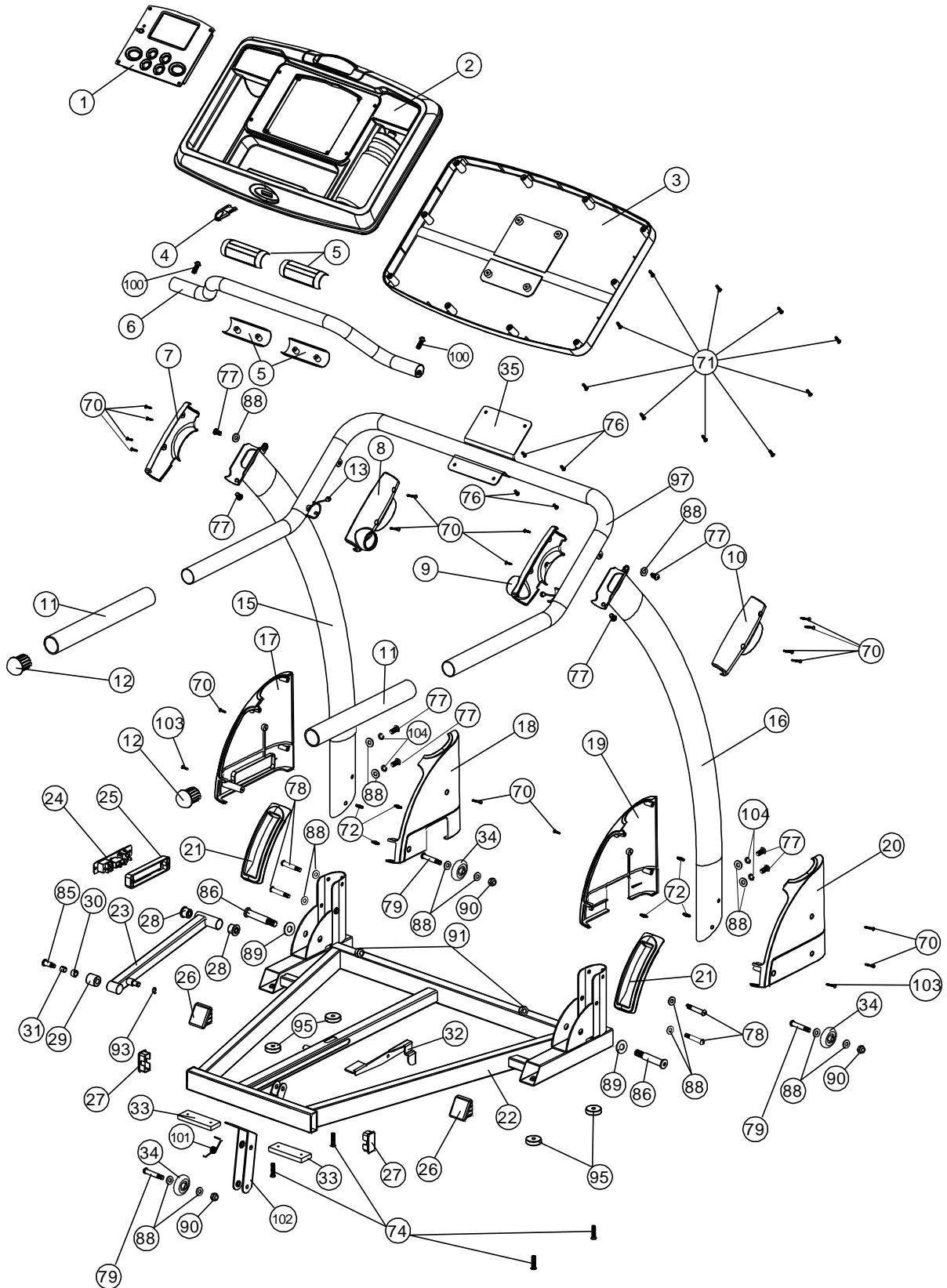



PARTS DIAGRAM

A MAJORITY OF THE PARTS SHOWN HERE HAVE BEEN PREASSEMBLED AT THE FACTORY.

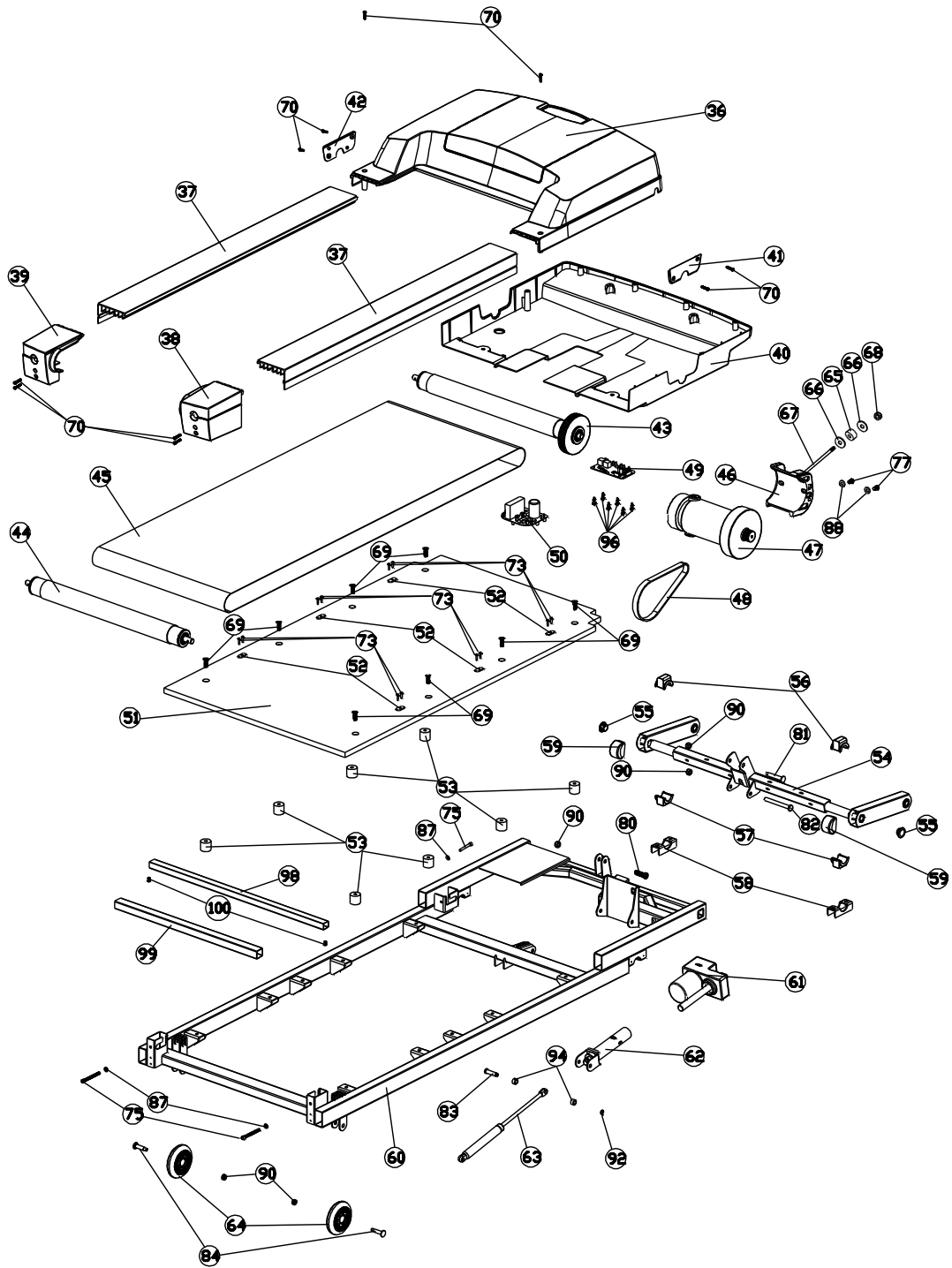

**ASSEMBLY****STEP 1:**

Remove your treadmill from the carton and place it on the floor in an open area as shown in FIG 1.

Raise the Right and Left Uprights (16 and 15) and secure with four M8 x Allen Bolt (77), four 8mm Spring Washer (104) and four Washers (88) from front of Right and Left Uprights. And attach M10 x 58mm Bolts (78) with two Washers (88) from the side of Right and Left Upright.

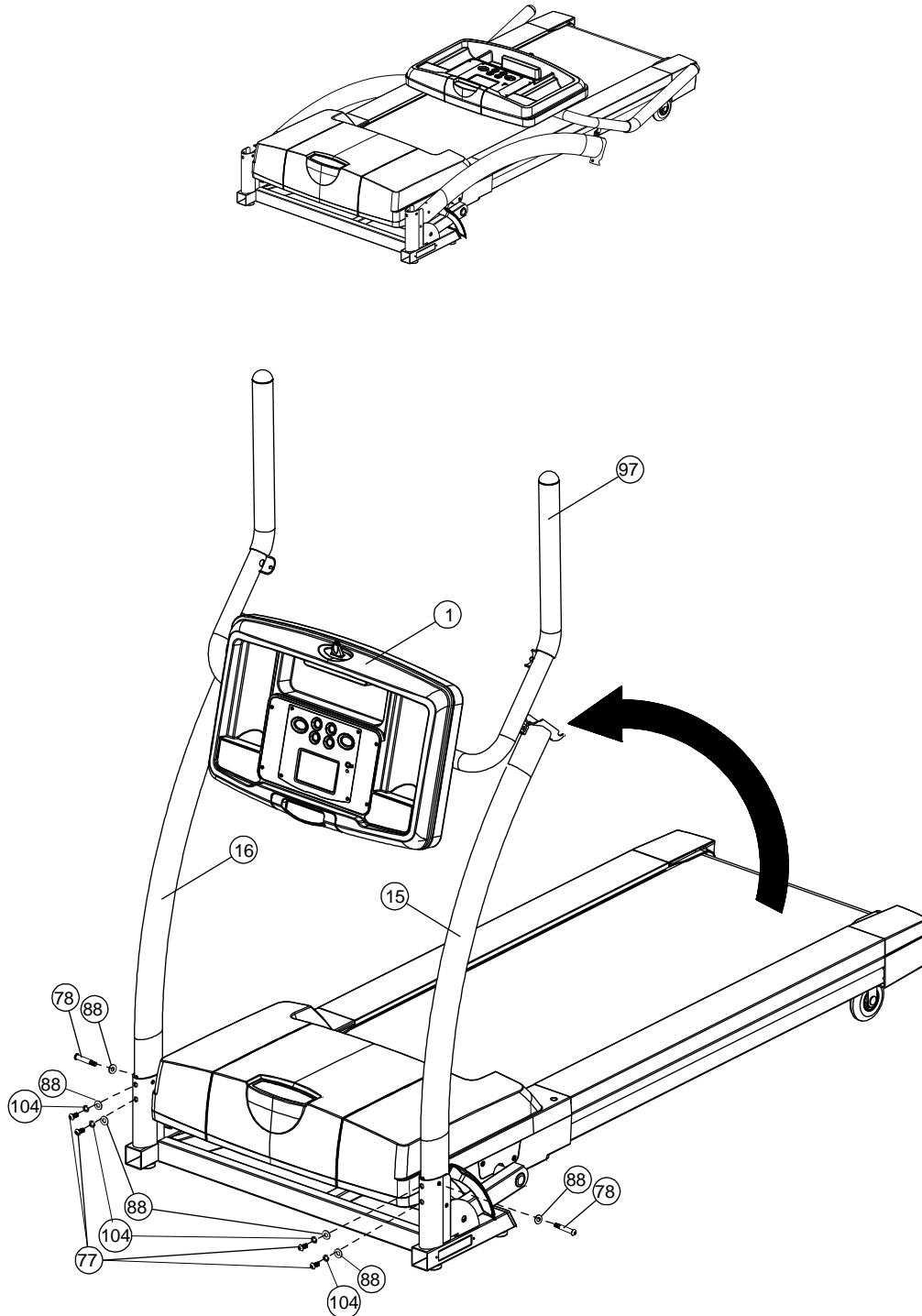
**FIG. 1**

ASSEMBLY**STEP 2:****FIG 2**

Rotate up the Handlebar (97) down as shown in FIG 2. Secure the Handlebar (97) in place using two M8 x 18 Allen Bolt (77) from underneath. Finally, fully tighten the two M8 x 18 Allen Bolt (77) at the pivot points as shown in FIG 3.

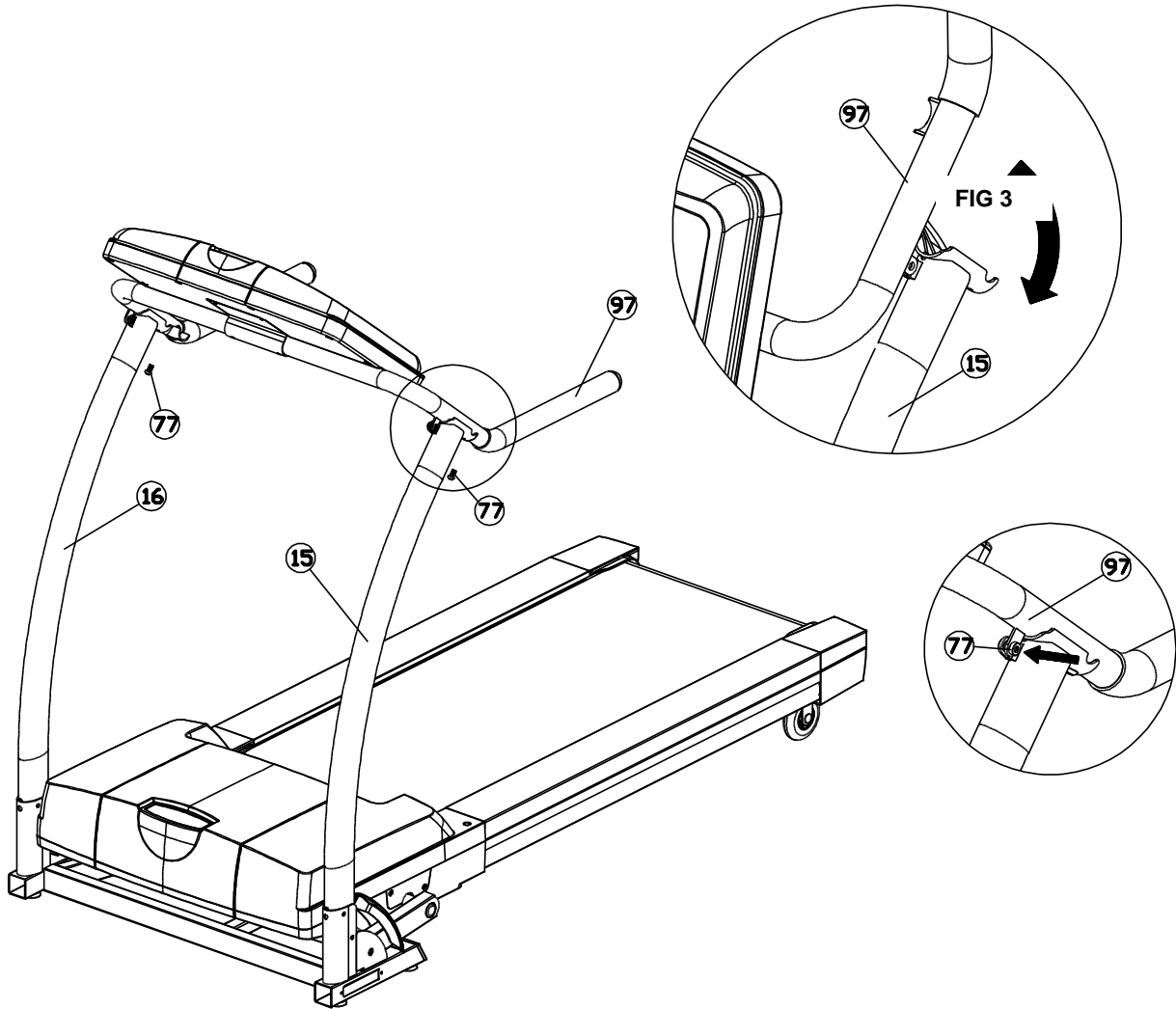

## ASSEMBLY

**STEP 3:**

Secure the Console Housing – Bottom (3) to the Console Plate (35) using two Screws M6 x 15 Screw (76).

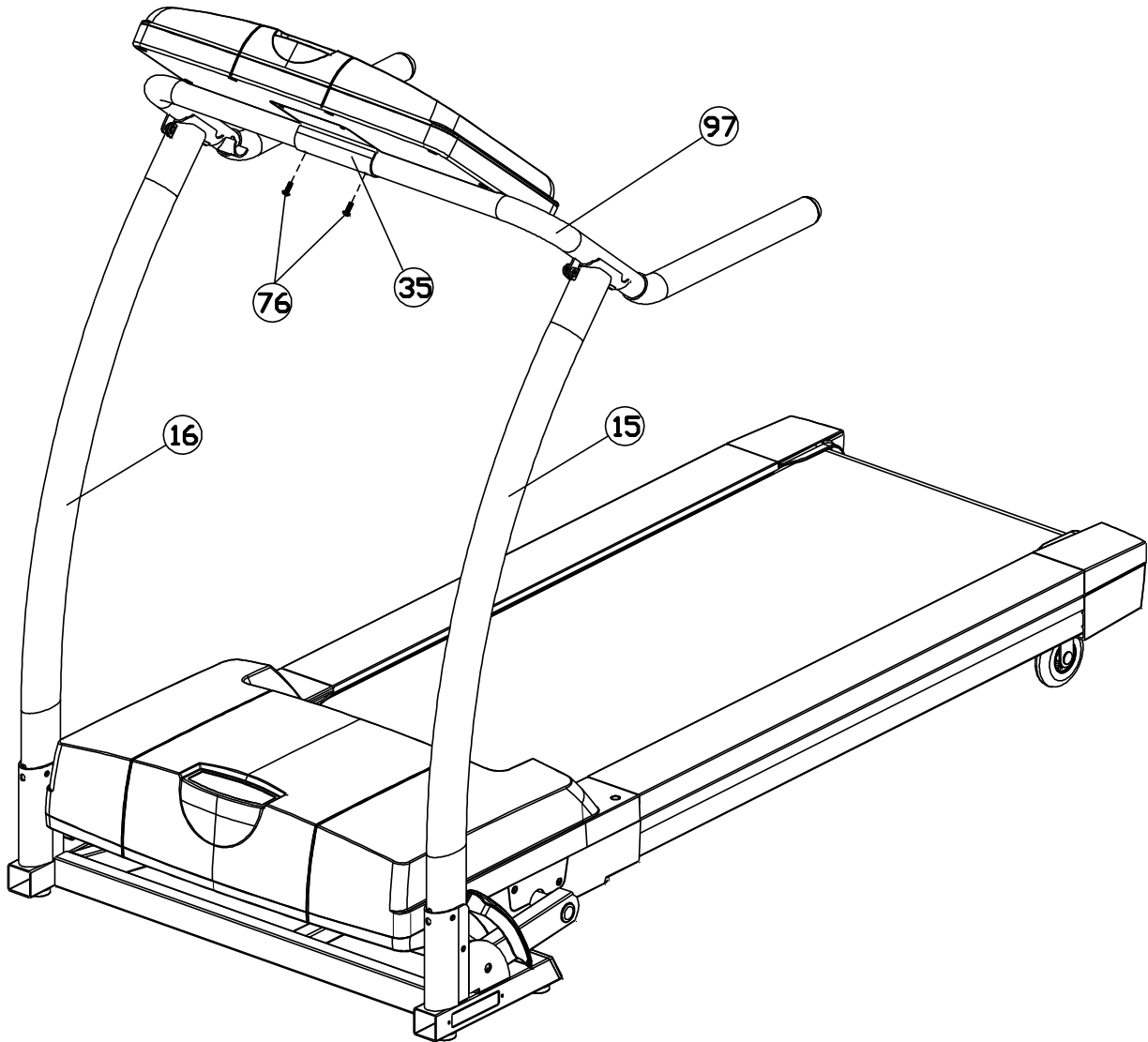

ASSEMBLY**STEP 4:**

Slide the Handlebar Cover – Left #2 (8) and Handlebar Cover – Right #2 (9) onto the Front Handlebar (6). Connect each of the EKG Pulse Wire (13) to each of the EKG Pulse Sensor (5).

Secure the Front handlebar (6) to the Handlebar (97) using two M8 x 30mm Screw (100).

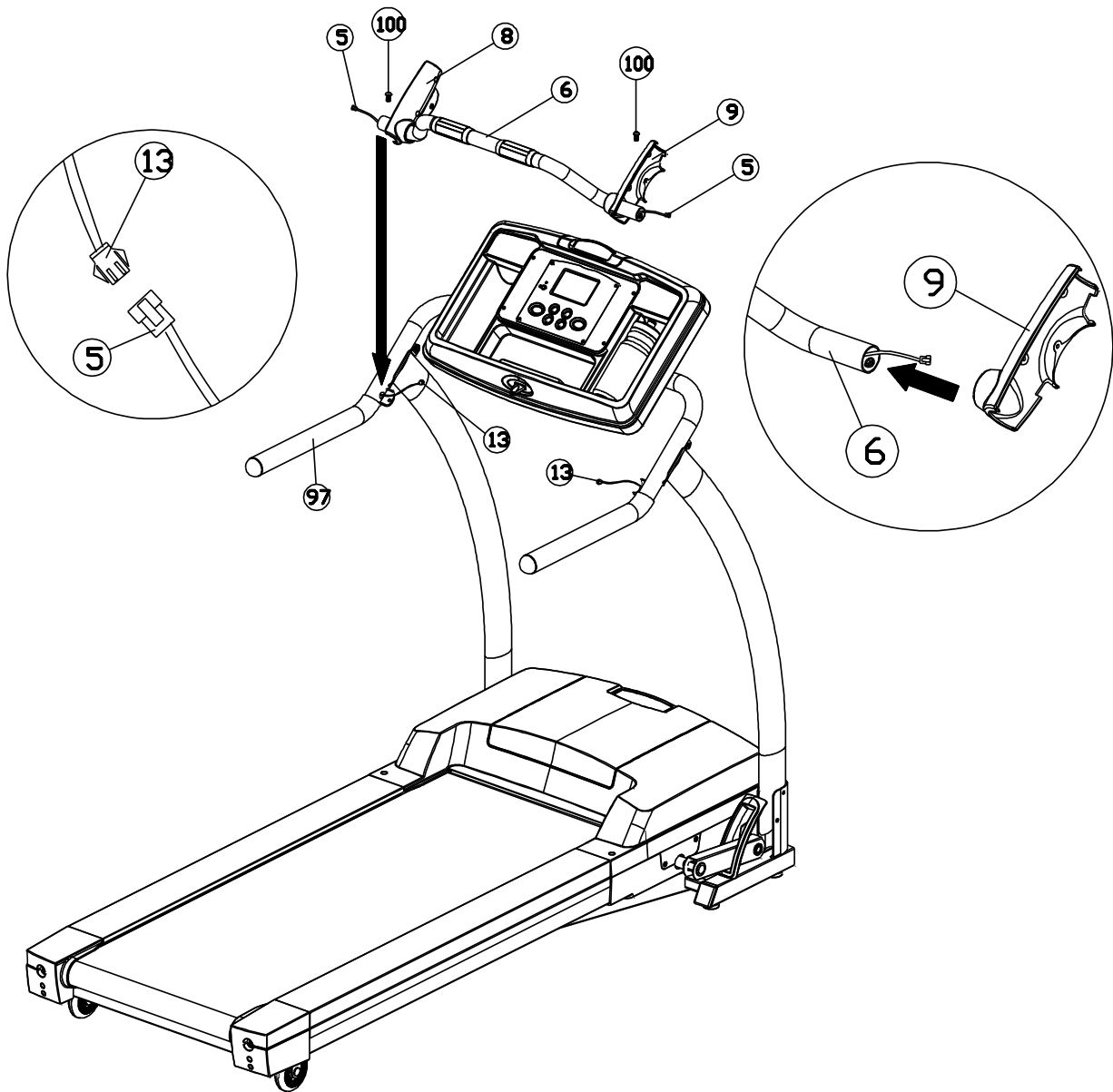

ASSEMBLY**STEP 5:**

Attach the Handlebar Cover – Left #1 (7) to the Handlebar Cover – Left #2 (8) and Left Upright (15) using six M4 x 15mm Screws (70). Attach the Handlebar Cover – Right #1 (10) to the Handlebar Cover – Right #2 (9) and Right Upright (16) using six M4 x 15mm Screws (70).

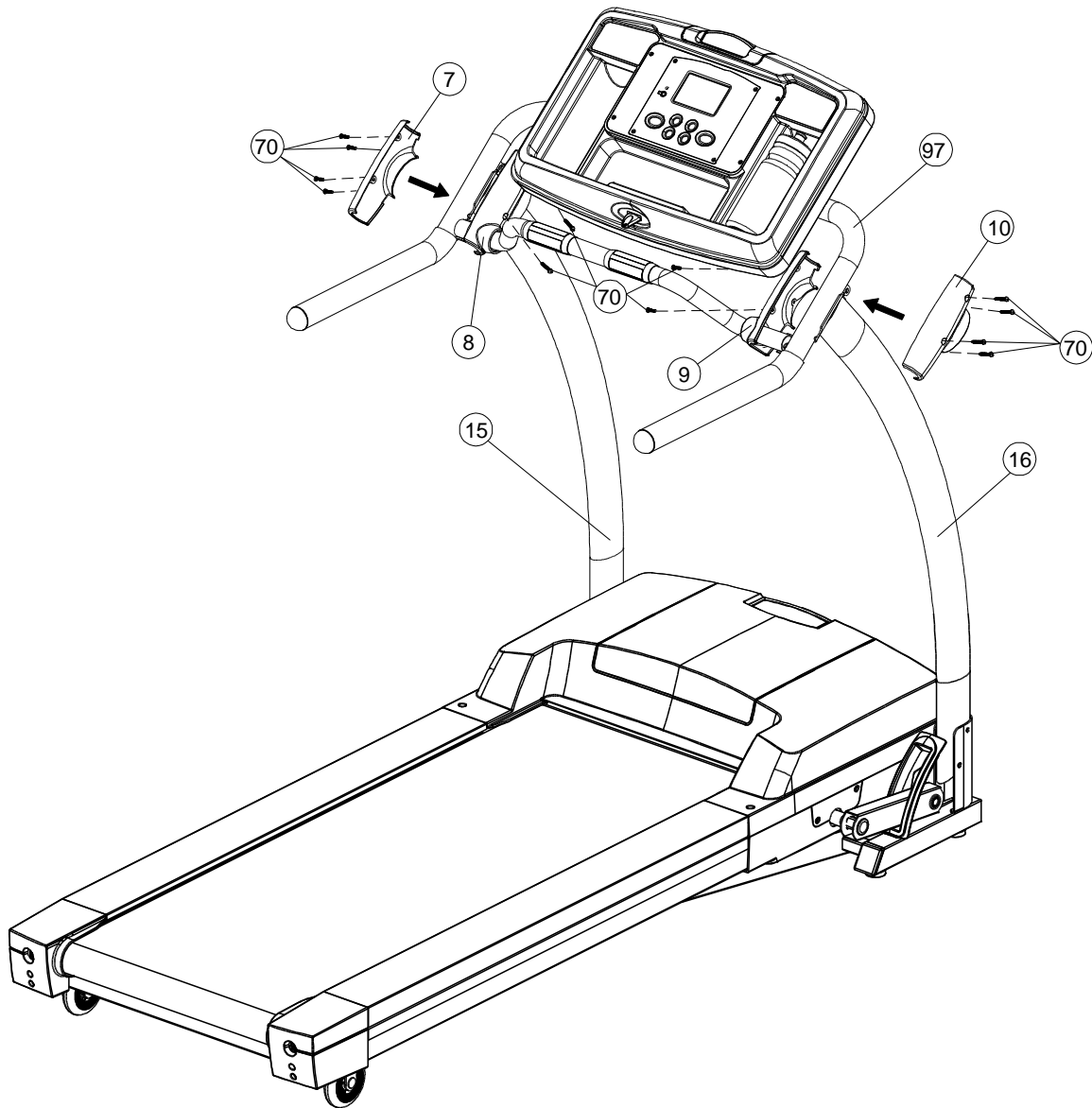

## ASSEMBLY

**STEP 6:**

Attach the Upright Base Cover – Left #2 (18) and Upright Base Cover – Left #1 (17) over the Left Upright (15). Secure using three Plastic Fixing Insert (72) and three M4 x 15mm Screw (70). Attach the Upright Base Cover – Right #2 (19) and Upright Base Cover – Right #1 (20) over the Right Upright (16). Secure using three Plastic Fixing Insert (72) and four M4 x 15mm Screw (70).

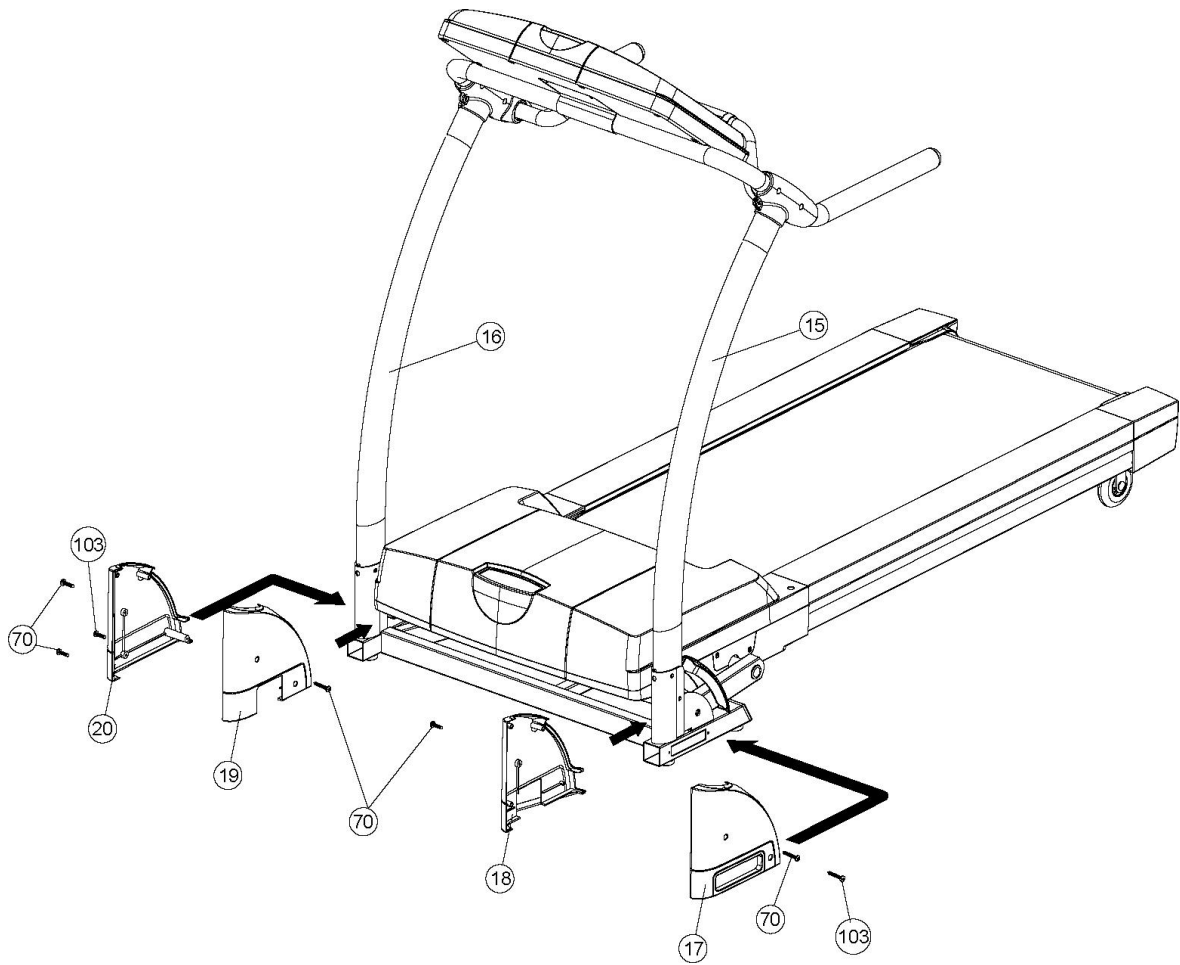

**FOLDING INSTRUCTIONS****FOLLOW THESE INSTRUCTIONS TO FOLD UP YOUR TREADMILL:**

Your treadmill can be folded up for space saving storage space. Simply lift the deck up from the rear of the treadmill and fold up until it locks in place. **TO PREVENT INJURY BE SURE YOU HAVE A FIRM HOLD WHEN RAISING THE DECK.** You will hear a “click” sound as the lock engages.

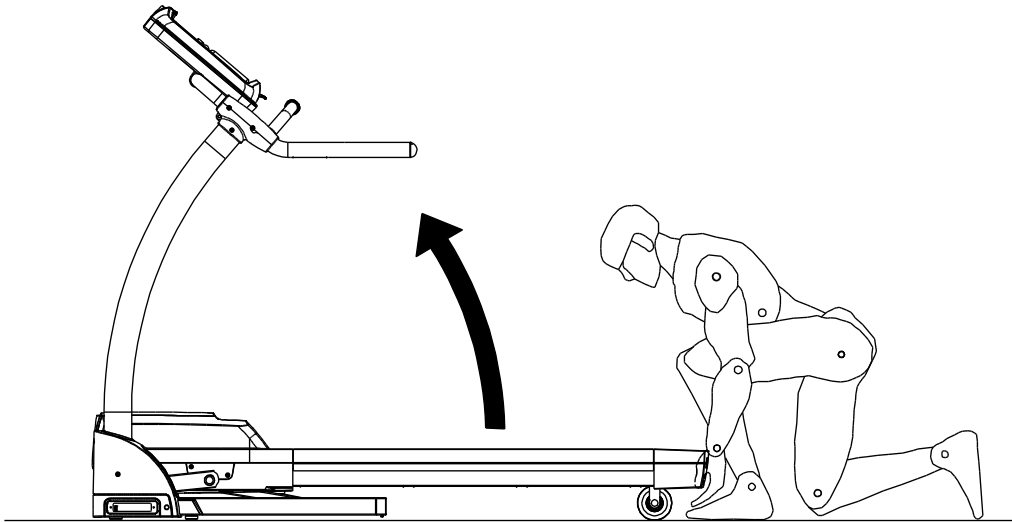

**Stand behind the treadmill and lift the deck up.**

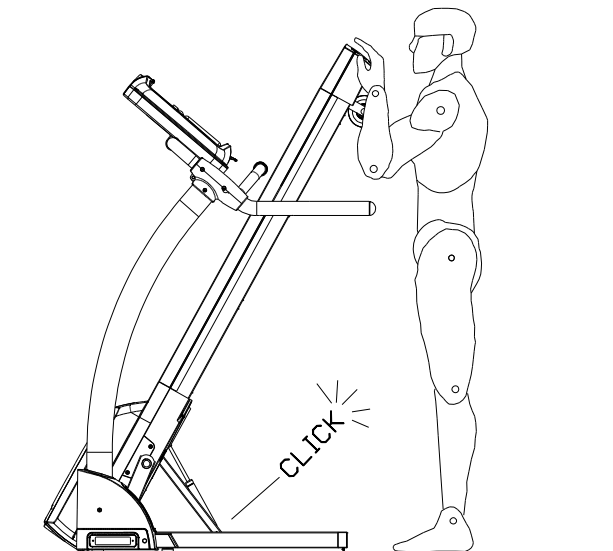

**Raise the deck up until the lock engages.**



## UNFOLDING INSTRUCTIONS

### **FOLLOW THESE INSTRUCTIONS TO UNFOLD YOUR TREADMILL:**

To unfold the treadmill for use, begin by standing behind and supporting the deck with your hands. Next release the lock with your foot by stepping on the release lever. **TO PREVENT INJURY BE SURE YOU HAVE A FIRM HOLD ON THE DECK BEFORE RELEASING THE LOCK.** Slowly lower the deck until it rests securely on the ground.

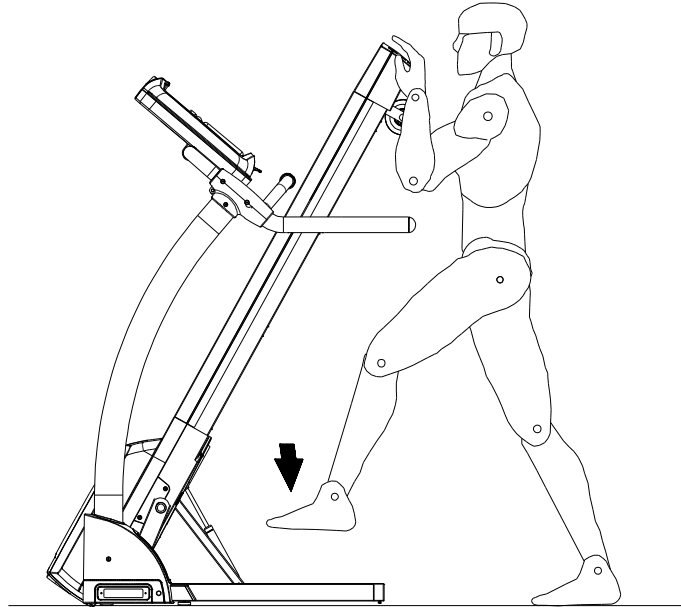

**Support the deck and release the lock with your foot.**

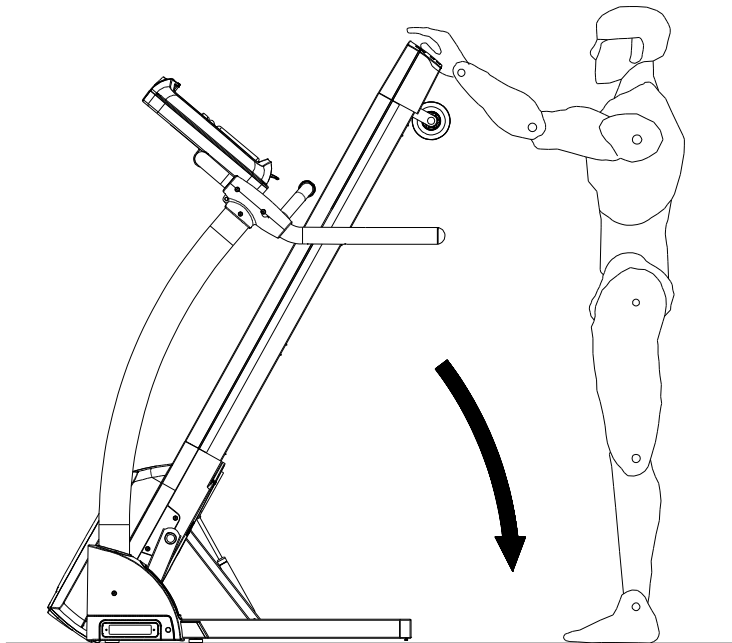

## TRANSPORT INSTRUCTIONS

### How to fold up the treadmill:

Your treadmill can be folded up for space saving storage. To do this follow the instructions here:

1. Start by first folding up the running deck as described on the FOLDING INSTRUCTIONS page in this manual. Then lift the treadmill a little bit up from the end of handlebars. You will see the Transportation Wheel Bracket spring out.

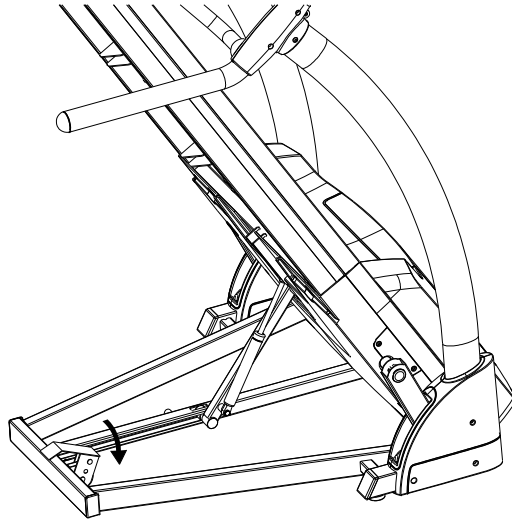

2. Lift the deck up from the rear of the treadmill and fold up until it locks in place.

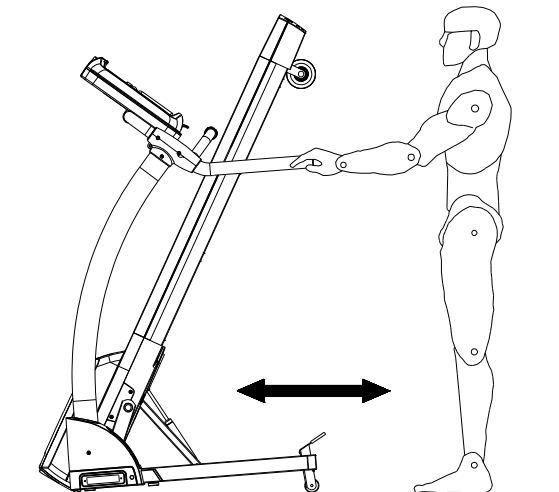

3. Once the treadmill is in place step on the Transportation Wheel Bracket to make the wheel back to place. Insert the lock pin back to Transportation Wheel Bracket. Then follow the UNFOLDING and STABILIZER ADJUSTMENT instruction pages in this manual to level the frame to the floor.

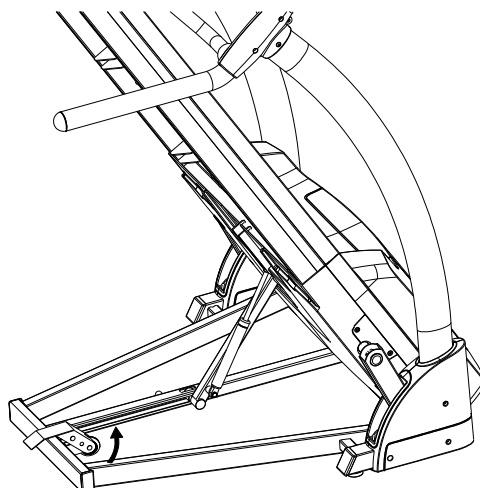

COMPUTER OPERATION

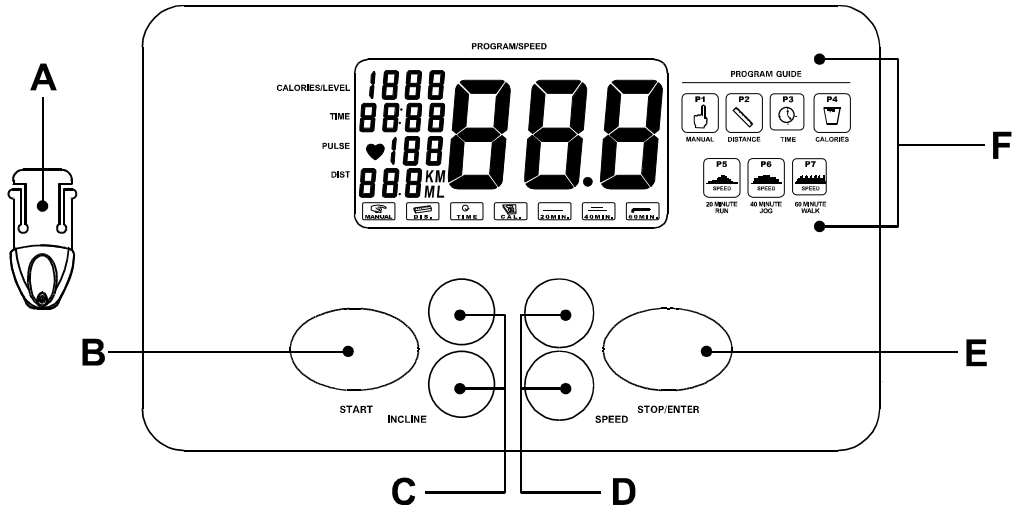

A  
B  
START Button

C  
D  
SPEED UP/DOWN Button

E  
F  
STOP/ENTER Button

Reference Guide

BUTTONS FUNCTION

**START** – Press to start exercise at initial speed 0.5MPH / 0.8KPH.

**STOP / ENTER**

- a. Press to confirm program and preset function values setting mode.
- b. Press to run setting procedure before pressing the START KEY.
- c. Press to stop exercise during workout time.

**SPEED UP**

- a. Press to increase exercise speed by 0.1MPH / KPH.

Safety Key

INCLINE UP/DOWN Buttons

## COMPUTER OPERATION

### SAFETY KEY

The safety key must be inserted into the slot on the console in order to operate the treadmill. Always insert the safety key and attach the clip to your clothing at your waist before beginning your workout. If you should encounter problems and need to stop the motor quickly, simply pull on the cord to disengage the safety key from the console. To continue operation first turn the power switch to off and set the speed controller to stop. Next turn the power switch to on and reinsert the safety key into the console.

### ENGLISH / METRIC CONVERSION

The treadmill computer display can show METRIC and ENGLISH information. This should be preset for your area by the factory. However, in case that the treadmill needs to be converted between METRIC and ENGLISH readout, please follow the procedure below:

Set the POWER SWITCH to ON. Press the START button on the computer and hold it. Insert the SAFETY KEY then release the START button. The computer will sound one short beep and the LCD will show "ML" (English) as the factory setting. Press INCLINE UP/DOWN button to switch between ML and KM (Metric) and press STOP/ENTER button to confirm the setting. The computer will sound a long beep and will return to the POWER ON mode with the new setting.

### POWER ON

Set the POWER SWITCH, located on the base frame, to ON and insert the SAFETY KEY. All LCD figures will light up with a short beep sound then display "0" except the SPEED, which will show "P1" and be blinking. The bottom program indication shows the MANUAL PROGRAM image. If there is no further operation to the computer for 3 minutes, the LCD will go off automatically. Press any button to return to the POWER ON mode.

### QUICK START

When the treadmill is in POWER ON status, press the START button to activate the QUICK START program. The speed LCD will count down 3 seconds with 3 short beep sounds then start from 0.5MPH/0.8KPH. Press the SPEED UP/DOWN button to change the speed. Press the INCLINE UP/DOWN button to elevate the treadmill. The TIME, CALORIES and DISTANCE will count up from 0.

### COMPUTER OPERATION:

After turning on the power the computer will show a full display for 2 seconds. The "P1" (manual program) will then begin blinking in the upper right corner of the LCD window. Press the INCLINE UP / DOWN buttons to select the desired program. Press the STOP/ENTER button to confirm the selected program then press the START button to start the program. Please refer to the following instructions for the different program options.

### PAUSE/STOP

During the workout, press the STOP/ENTER button once to pause the treadmill. Press the STOP/ENTER button twice to delete all the workout data and return to POWER ON status.

### PROGRAM 1 – MANUAL/QUICK START

Press the INCLINE UP / DOWN button to select the program "P1", then press the STOP/ENTER button to select the program and then press the START key to start exercising. The speed will start from 0.5 MPH / 0.8 KPH. The incline will start from level 0. Press the SPEED UP/DOWN BUTTON to adjust the speed and press the INCLINE UP/DOWN button to adjust the incline level. Time, Distance and Calories all count up from 0.

## COMPUTER OPERATION

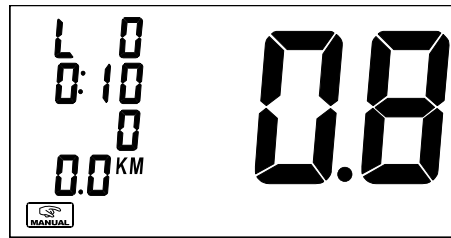
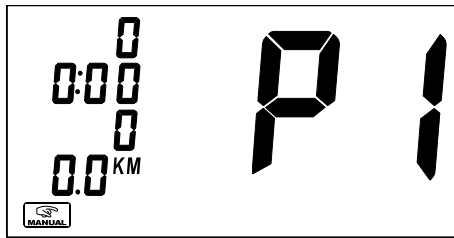
**PROGRAM 2 – TARGET DISTANCE**

Press the INCLINE UP/DOWN button until the LCD shows P2 and is blinking. The bottom program indication shows the DISTANCE PROGRAM image. Press the STOP/ENTER button to select the program. The DISTANCE digits will show 0.0 and be blinking. Press the INCLINE UP/DOWN button to adjust the target distance and press the STOP/ENTER button to confirm the target distance. Press the START button to start the program. The speed will start from 2.0 MPH / 3.2 KPH and the incline will start from level 0. Press the SPEED UP/DOWN button to adjust the speed and press the INCLINE UP/DOWN button to adjust the incline level. Time and Calories will count up from 0 and the distance will count down from the target distance.

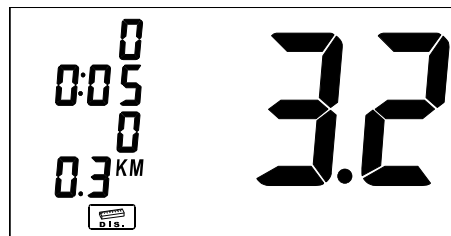
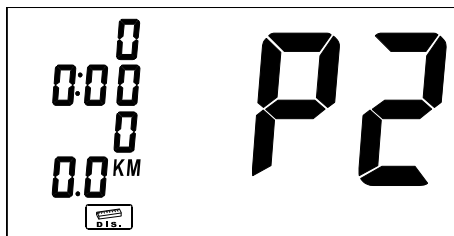
**PROGRAM 3 – TARGET TIME**

Press the INCLINE UP/DOWN button until the LCD shows P3 and is blinking. The bottom program indication will show the TIME PROGRAM image. Press the STOP/ENTER button to select the program. The TIME display digits will show 0:00 and be blinking. Press the INCLINE UP/DOWN button to adjust the target workout time and press the STOP/ENTER button to confirm the target workout time. Press the START button to start the program. The Speed will start from 2.0 MPH / 3.2 KPH and the Incline will start from level 0. Press the SPEED UP/DOWN button to adjust the speed and press the INCLINE UP/DOWN button to adjust the incline level. The Distance and Calories will count up from 0 and the Time will count down from the target workout time.

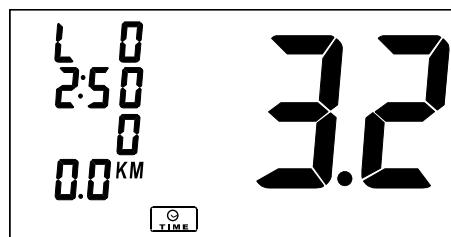
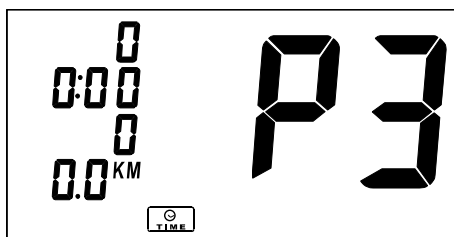

## COMPUTER OPERATION

## PROGRAM 4 – TARGET CALORIES

Press the INCLINE UP/DOWN button until the LCD shows P4 and is blinking. The bottom program indication will show the CALORIES PROGRAM image. Press the STOP/ENTER button to select the program. The CALORIES display digits will show 0 and be blinking. Press the INCLINE UP/DOWN button to adjust the target calories burned and press the STOP/ENTER button to confirm the target calories burned. Press the START button to start the program. The Speed will start from 2.0 MPH / 3.2 KPH and the Incline will start from level 0. Press the SPEED UP/DOWN button to adjust the speed and press the INCLINE UP/DOWN button to adjust the incline level. The Distance and Time will count up from 0 and the Calories will count down from the target workout time.

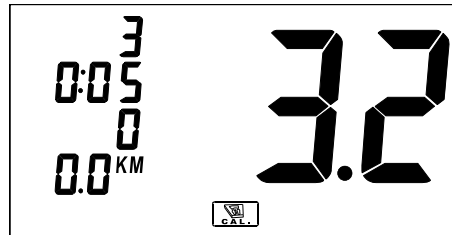
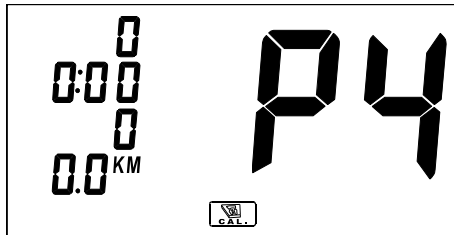

## PROGRAM 5 – 20 MINUTES RUNNING PROGRAM

Press the INCLINE UP/DOWN button until the LCD shows P5 and is blinking. The bottom program indication will show the 20 MIN. PROGRAM image. Press the STOP/ENTER button to select the program. Press the START button to start the program. The Speed will start from 2.0 MPH/3.2 KPH and the incline will start from level 0. Press the SPEED UP/DOWN button during the workout if you want to overwrite the preset speed program. Press the INCLINE UP/DOWN button to adjust the incline level. The TIME will count down from 20 minutes and DISTANCE and CALORIES will count up from 0.

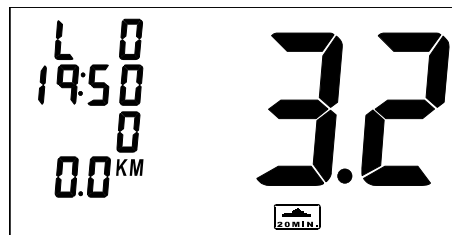
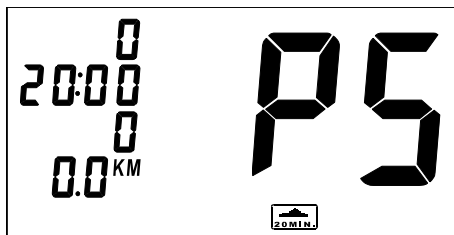

## SPEED CHART

TIME  
SPEED

MPH  
KPH

20-18

2

3.2

18-15

5

8

15-12

5.6

9

12-9

6.3

10

9-6

6.9

COMPUTER OPERATION**PROGRAM 6 – 40 MINUTES JOGGING PROGRAM**

Press the INCLINE UP/DOWN button until the LCD shows P6 and is blinking. The bottom program indication will show the 40 MIN. PROGRAM image. Press the STOP/ENTER button to select the program. Press the START button to start the program. The Speed will start from 1.9 MPH/3.0 KPH and the incline will start from level 0. Press the SPEED UP/DOWN button during the workout if you want to overwrite the preset speed program. Press the INCLINE UP/DOWN button to adjust the incline level. The TIME will count down from 40 minutes and the DISTANCE and CALORIES will count up from 0.

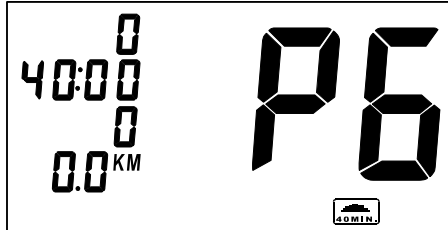
**SPEED CHART**

TIME  
SPEED

MPH  
KPH

40-37  
1.9  
3

37-34  
2.5  
4

34-31  
3.1  
5

31-28  
3.8  
6

28-24  
4.4  
7

24-16  
5  
8

16-4  
5.6  
9

4-2  
6.3  
10

2-0  
1.9  
3

## MAINTENANCE

### How to maintain your treadmill:

Proper maintenance is very important to ensure your treadmill is always in top working condition. Improper maintenance could cause damage or shorten the life of your treadmill.

- **Important:** Never use abrasives or solvents to clean the treadmill. To prevent damage to the computer, keep liquids away and keep it out of direct sunlight.
- Inspect and tighten all parts of the treadmill regularly. Replace any worn parts immediately.

### BELT ADJUSTMENT:

The running belt has been properly adjusted at the factory. However transportation, uneven flooring or other unpredicted reasons could cause the belt to shift off center resulting in the belt rubbing with the plastic side rail or end caps and possibly causing damage. To adjust the belt back to it's proper position please follow the directions below:

1. If your belt tends to walk to the right, rotate the right tension bolt clockwise. We recommend adjustments of 1/4 turn at a time, and follow with a test. If your belt continues to walk to the right, simply adjust the left belt tension bolt by turning it 1/4 turn counterclockwise, and follow with a test.
2. If your belt tends to walk to the left, rotate the left tension bolt clockwise 1/4 turn at a time, and follow with a test. If the belt continues to walk to the left, simply adjust the right tension bolt counterclockwise.
3. If your belt appears to be loose, simply tighten both bolts evenly 1/4 turn. If it appears tight, simply loosen both bolts evenly 1/4 turn.

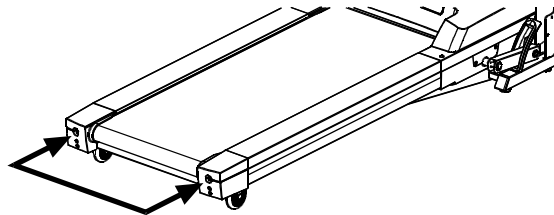

**Right and left tension bolts are located at the rear of the treadmill.**

### DECK LUBRICATION:

The walking belt has been pre-lubricated at the factory. However, it is recommended that the walking board be checked periodically for lubrication to ensure optimal treadmill performance. Your treadmill should not have to be lubricated usually within the first year or 500 hours of use.

Every 30 days or 30 hours of operation lift the sides of the walking belt and feel the top surface of the walking board as far as you can reach. If you feel signs of silicone, no further lubrication is required. If it feels dry to the touch, follow the instructions below.

Please use a non-petroleum based silicone.



## MAINTENANCE

### To apply lubricant to the walking belt:

1. Position the walking belt so that the seam is located on top and in center of the walking board.
2. Insert the spray nozzle into the spray head of the lubricant can.
3. While lifting the side of the walking belt, position the spray nozzle between the walking belt and the board approximately 15 cm (6 inches) from the front of the treadmill. Apply the silicone spray to the walking board, moving from the front of the treadmill to the rear. Repeat this on the other side of the belt. Spray approximately 4 seconds on each side.
4. Allow the silicone to "set" for 1 minute before using the treadmill.

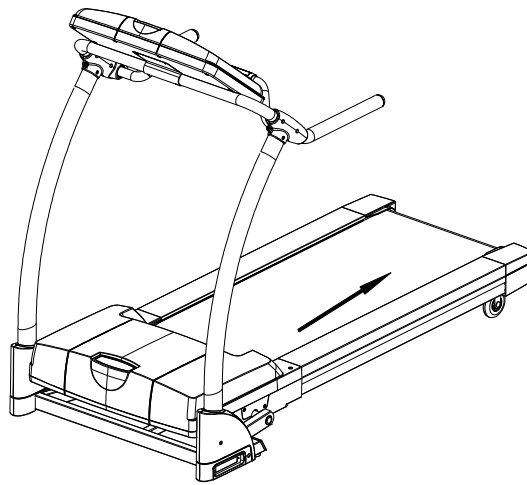

**Spray lubricant from front to back.**

### CLEANING:

Routine cleaning of your treadmill will extend the product's life.

- **Warning:** To prevent electrical shock, be sure the power to the treadmill is OFF and the power cord is unplugged from the wall electrical outlet before attempting any cleaning or maintenance.
- **Important:** Never use abrasives or solvents to clean the treadmill. To prevent damage to the computer, keep liquids away and keep it out of direct sunlight.
- **After each workout:** Wipe off the console and other treadmill surfaces with a clean, water dampened soft cloth to remove excess perspiration.
- **Weekly:** Use of a treadmill mat is recommended for ease of cleaning. Dirt from your shoes contacts the belt and eventually makes it to underneath the treadmill. Vacuum underneath treadmill once a week.

## IMPORTANT STEPS

**Warning:**

Before using this product, please consult your personal physician for a complete physical examination. Frequent and strenuous exercise should be approved by your doctor first. If any discomfort should result from your use of this product, stop exercising and consult your doctor. Proper usage of this product is essential. Please read your manual carefully before exercising.

Please keep all children away from the equipment during use and when equipment is unattended.

Always wear appropriate clothing, including athletic shoes, when exercising. Do not wear loose clothing that could become caught during exercising.

Make sure that all bolts and nuts are tightened when equipment is in use. Periodic maintenance is required on all exercise equipment to keep it in good condition.

**Before beginning:**

How you begin your exercise program depends on your physical condition. If you have been inactive for several years, or are severely overweight, you must start slowly and increase your time gradually, a few minutes per week.

Initially you may be able to exercise only for a few minutes in your target heart rate zone. However, your aerobic fitness will improve over the next six to eight weeks. Don't be discouraged if it takes longer. It's important to work at your own pace. Ultimately, you'll be able to exercise continuously for 30 minutes. And the better your aerobic fitness, the harder you will have to work to stay in your target heart rate zone. But remember these essentials:

- Contact your physician before starting a workout or training program. Have your doctor review your training and diet programs to advise you of a workout routine you should adopt.
- Begin your training program slowly with realistic goals that have been set by you and your doctor.
- Supplement your program with some type of aerobic exercise such as walking, jogging, swimming, dancing and/or bicycling. Monitor your pulse frequently. If you do not have an electronic heart rate monitor, have your physician show you the proper way to manually check your pulse by using your wrist or neck. Establish your target heart rate based on your age and condition.
- Drink plenty of fluids during the course of your routine. You must replace the water content lost from excessive exercising to avoid dehydration. Avoid drinking large amounts of cold liquids. Fluids should be at room temperature when consumed.

**TARGET HEART RATE****Finding your pulse:**

To make sure your heart is beating in its target zone, you'll need to know how to monitor your heart rate. The easiest way is to feel the pulse in the carotid artery on either side of your neck, between the windpipe and the large neck muscles. Count the number of beats in ten seconds, and then multiply that number by six. This gives you the number of beats per minute.

How fast should your heart beat during aerobic exercise? Fast enough to reach and stay in its "target zone," a range of beats per minute that is largely determined by your age and physical condition. To determine your target zone, consult the chart we have provided.

**FIND YOUR TARGET HEART RATE****HEART RATE** in beats per minute**200****180**

**MUSCLE CHART**

**Targeted muscle groups:**

The exercise routine that is performed on this product will develop primarily lower body muscle groups. These muscle groups are shown in gray color on the chart below.

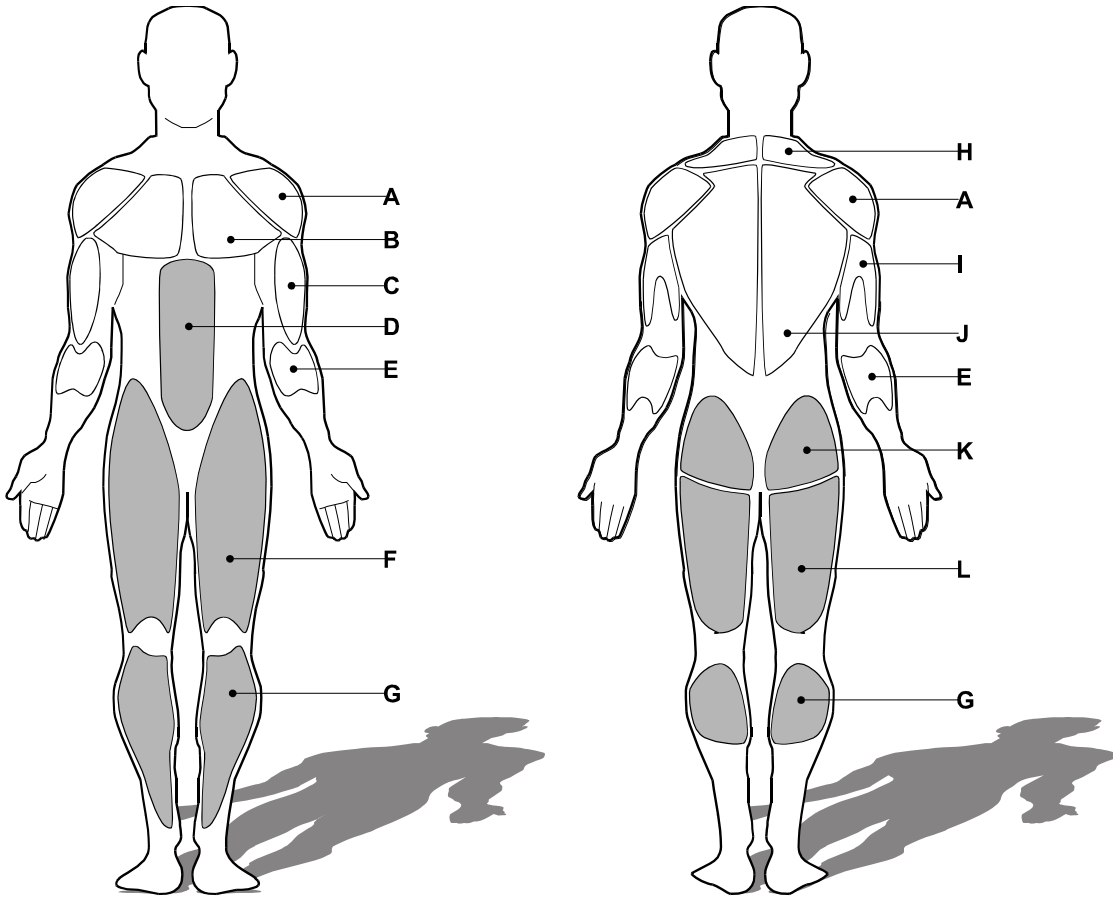

Shoulder muscles

A

Pectoral muscles

B

Bicep muscle

C

Abdominal muscles

D

Forearm muscles

E

F

G

**STRETCHING ROUTINE****Warm up and cool down:**

A successful exercise program consists of a warm-up, aerobic exercise, and a cool-down. Do the entire program at least two or three times a week, resting for a day between workouts. After several months, you can increase your workouts to four or five times per week.

Warming up is an important part of your workout, and should begin every session. It prepares your body for more strenuous exercise by heating up and stretching out your muscles, increasing your circulation and pulse rate, and delivering more oxygen to your muscles. At the end of your workout, repeat these exercises to reduce sore muscle problems. We suggest the warm-up and cool-down exercises on the following pages:

**Toe Touch:**

Slowly bend forward from your waist, letting your back and shoulders relax as you stretch toward your toes. Reach down as far as you can and hold for 15 counts.

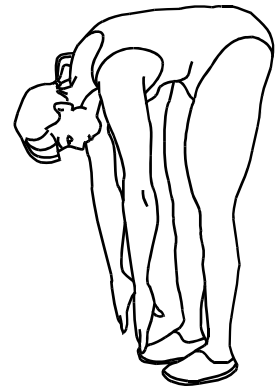
**Shoulder Lift:**

Lift your right shoulder up toward your ear for one count. Then lift your left shoulder up for one count as you lower your right shoulder.

**Head Roll:**

Rotate your head to the right for one count, feeling the stretch up the left side of your neck. Next, rotate your head back for one count, stretching your chin to the ceiling and letting your mouth open. Rotate your head to the left for one count, and finally, drop your head to your chest for one count.



**STRETCHING ROUTINE****Hamstring Stretch:**

Sit with your right leg extended. Rest the sole of your left foot against your right inner thigh. Stretch toward your toe as far as possible. Hold for 15 counts. Relax and then repeat with left leg extended.

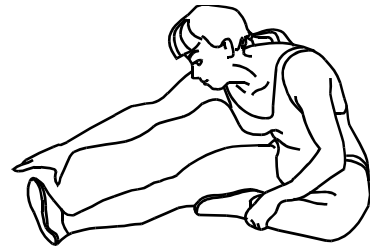
**Inner Thigh Stretch:**

Sit with the soles of your feet together with your knees pointing outward. Pull your feet as close into your groin as possible. Gently push your knees towards the floor. Hold for 15 counts.

**Side Stretch:**

Open your arms to the side and continue lifting them until they are over your head. Reach your right arm as far upward toward the ceiling as you can for one count. Feel the stretch up your right side. Repeat this action with your left arm.

**Calf-Achilles Stretch:**

Lean against a wall with your left leg in front of the right and your arms forward. Keep your right leg straight and the left foot on the floor; then bend the left leg and lean forward by moving your hips toward the wall. Hold, and then repeat on the other side for 15 counts.

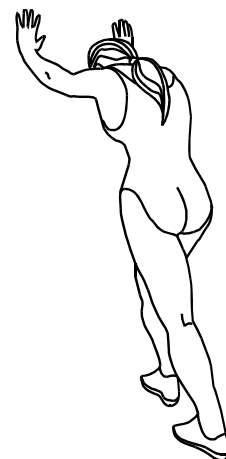

## TROUBLESHOOTING

### Troubleshooting

**NOTE:** Do not touch any internal electric wires without consulting the manufacturer.

#### **Treadmill will not start:**

1. Make sure the power cord is plugged into a surge protector, the surge protector is plugged into a properly grounded outlet and the surge protector is turned on (refer to the Power Requirements section in this manual).
2. Check the circuit breaker reset switch located on the front of the treadmill. Turn the power off, wait 5 minutes then press the rest switch.
3. Check the house electrical breaker box and the circuit breaker for the room the treadmill is located in. If it has tripped, reset or have an electrician replace the breaker in home.
4. Have an electrician check for inadequate voltage at the outlet.

#### **Treadmill loses power during use:**

1. Check the circuit breaker reset switch located on the front of the treadmill. Turn the power off, wait 5 minutes then press the rest switch.
2. Check the house electrical breaker box and the circuit breaker for the room the treadmill is located in. If it has tripped, reset or have an electrician replace the breaker in home.

#### **Treadmill walking belt slips or is not centered on rear roller:**

Refer to the Belt Adjustment section of this manual.



**PHOENIX**  
HEALTH & FITNESS INC.®

Phoenix Health & Fitness  
12169 Santa Margarita Ct.  
Rancho Cucamonga, CA 91730

Toll Free Customer Service:  
**1.888.535.8637**

Website:  
[www.phoenixhealthandfitness.com](http://www.phoenixhealthandfitness.com)