

# **CL-300 SERIES**

## **UPS**

**100-120-160-200-250-300 kVA**

**3 Phase Input - 3 Phase Output**

**USER MANUAL**





# CONTENTS

<b>I. GENERAL DESCRIPTION .....</b>	<b>1</b>
1.1 Introduction .....	1
1.2 Design Concept.....	2
1.2.1 OPERATING MODES OF UPS.....	3
1.3 Technical Specifications.....	6
<b>II. UPS INSTALLATION .....</b>	<b>7</b>
2.1 Introduction .....	7
2.2 Unpacking .....	7
2.3 Equipment Positioning .....	7
2.4 Connecting the UPS Power Cables .....	8
2.4.1 Safety Earth .....	9
2.4.2 Cable connection procedure .....	9
2.4.3 UPS Power Cable Connection Terminals .....	10
2.4.4 Battery Installation.....	12
<b>III. FRONT PANEL .....</b>	<b>15</b>
3.1 Introduction .....	15
3.2 Front Panel Menu Descriptions.....	15
3.2.1 MEASURES Menu Items .....	16
3.2.2 ALARMS Menu Items .....	16
3.2.3 INFORMATION Menu Items .....	16
3.2.4 ADJUST Menu Items .....	17
3.2.5 OPTIONS Menu Items .....	17
3.2.6 COMMAND Menu Items .....	18
3.2.7 TIME MENU ITEMS.....	19
3.2.8 SERVICE Menu Items.....	19
3.3 STATUS Messages.....	19
3.4 Shutdown messages.....	20
3.5 Fault Messages and Quick Troubleshooting .....	20
<b>IV. PARALLEL OPERATION .....</b>	<b>23</b>
4.1 Introduction .....	23
4.2 Parallel Operation Modes of CL-300P Series UPSs .....	24
4.2.1. PARALLEL mode .....	24
4.2.2. REDUNDANT mode.....	24
4.2.3. N+1 REDUNDANT mode .....	25

<b>V. OPERATING INSTRUCTIONS.....</b>	<b>28</b>
5.1 INTRODUCTION.....	28
5.2 OPERATING INSTRUCTIONS FOR A SINGLE UPS UNIT. (ONLINE OPERATION) ....	28
5.2.1 Procedure For Turning On The UPS To Supply The Load From A Complete Power-Off Condition.....	28
5.2.2 Power Off .....	28
5.2.3 Switching into Maintenance Bypass Mode.....	29
5.2.4 Switching From Maintenance Bypass Into Normal Operation .....	29
5.3 OPERATING INSTRUCTIONS FOR PARALLEL CONNECTED UPSs. ....	29
5.3.1 Procedure For Turning on the UPS (First Installation) .....	29
5.3.2 Power Off .....	30
5.3.3 Switching the Parallel UPS System into Maintenance Bypass Mode (uninterrupted transfer) .....	30
5.3.4 Switching the Parallel UPS system into Normal Operation .....	30
From a Maintenance Bypass Power down Condition. (uninterrupted transfer) .....	30
<b>VI. MAINTENANCE .....</b>	<b>31</b>
6.1 Scheduled Maintenance.....	31
6.2 Daily checks.....	31
6.3 Weekly checks .....	31
6.4 Annual maintenance .....	32
6.5 UPS Storage and transportation .....	32
<b>VII. FAULTS AND TROUBLESHOOTING .....</b>	<b>33</b>
7.1 General Procedure for Fault Checking And Troubleshooting .....	33
<b>VIII. UPS REMOTE MONITORING AND CONTROL .....</b>	<b>34</b>
8.1 Using Serial Port .....	34
8.1.1 Communication Routing Switch .....	34
8.2 Serial Communication Cable .....	35
8.3 Modem Connection .....	35
8.3.1 Hardware Configuration .....	35
8.3.2 Functioning Principle.....	35
8.3.3 Modem programming procedure .....	36
8.3.3.1 SMART Modem Programming (PC modem).....	36
8.3.4 Modem –UPS Connection Cable .....	36
8.4 Dry Contact (Interface) Connections .....	36
8.5 Remote Monitoring Panel.....	37

## SAFETY

### IMPORTANT NOTICES

1. Read instructions carefully before installing and starting the UPS
2. All warnings in the manual should be adhered to.
3. All operating instructions should be followed.
4. The unit should be supplied by a grounded outlet. Do not operate the unit without a ground source.
5. Power cord of the UPS should be routed carefully so that they are not to be walked on.
6. Please save this manual.
7. Please save or recycle the packaging materials.

### WARNING!

- Do not insert any object into ventilation holes or other openings.
- To reduce the risk of fire or electric shock, install in temperature and humidity controlled indoor area free of conductive contaminants.
- To reduce the risk of fire, replace fuses with the same type and rating when necessary.

### CAUTION!

- **Only qualified personnel should install or service UPS/batteries.**
- **Risk of electric shock, do not remove covers. No user serviceable parts inside, refer servicing to qualified service personnel.**
- The output may be energized when the unit is not connected to a mains supply.
- **Risk of electric shock! Hazardous live parts inside. This unit is energized from the battery supply even when the input AC power is disconnected.**
- To reduce the risk of electric shock, disconnect the UPS from the mains supply before installing a computer interface signal cable. Reconnect the power cord only after signaling interconnections have been made.

### CAUTION !

**Units are designed to operate on the concrete floor.**

### ABOUT THE BATTERIES

#### **CAUTION: RISK OF ELECTRIC SHOCK!**

**The battery circuit is not isolated from the mains voltage. Hazardous voltages may occur between the battery terminals and the ground!**

- A battery can present a risk of electric shock or burn from high short circuit currents. The following precautions should be taken when working on batteries :
  - \* Remove watches, rings or other metal objects.
  - \* Use tools with insulated handles.
- The batteries in this UPS are recyclable. Batteries must be disposed of according to local environmental laws. The batteries contain lead and pose a hazard to the environment and human health if not disposed of properly.
- Do not dispose of batteries in a fire. The batteries may explode. Do not open or mutilate the batteries. They contain an electrolyte which is toxic and harmful to the skin and eyes. If electrolyte comes into contact with the skin the affected area should be washed immediately.
- The internal energy source (the battery) cannot be de-energized by the user.
- When changing batteries, install the same number and same type of batteries.

## I. GENERAL DESCRIPTION

### 1.1 Introduction

CL-300P Series Uninterruptible Power Supplies are double-conversion, on-line UPS's manufactured with the latest IGBT and PWM technology, to produce an uninterruptible, microprocessor controlled pure sine wave output to critical loads.

CL-300P Series units are 3-phase in/3-phase out devices, and they are installed between a three phase critical load, and a 3-phase+N mains supply

The advantages of using CL-300P UPS:

- **Power blackout protection:**  
If the mains power fails, the UPS continues to supply the critical load using the energy stored in its batteries, keeping the load immune from power disturbances.
- **Increased power quality:**  
The UPS has its own internal voltage and frequency regulating circuits, which ensure that, its output to the critical load is maintained within close tolerances, independent of voltage and frequency variations on the mains power lines.
- **Increased noise rejection:**  
By rectifying the input AC power to DC power and then converting it back to AC (Double-Conversion) any electrical noise present on the input mains supply line is effectively isolated from the UPS output. Therefore the critical load is supplied with only clean and uninterrupted AC power.

### Basic Features :

- Microprocessor Controlled
- Double Conversion, on-line UPS
- IGBT Rectifier (PWM)
- High Input PF
- Low THDI
- IGBT Inverter (PWM)
- Sinusoidal output Waveform.
- Low output Voltage THD
- High Nonlinear Load capacity (CF 3:1)
- High Unbalanced loading capability.
- Efficiency Up to 94%
- Overload and short circuit Protection
- Overtemperature protection
- Static Bypass Switch
- Maintenance Bypass Switch
- Separate bypass input facility (split Bypass)
- Parallel Operation (Optional)
- LCD Display
- Alarm History (Up to 128 Alarms)
- Real time clock (date and time)
- Emergency Power off (EPO)
- Cold-start feature
- Dual Polarity Batteries (Internal and/or external)
- Automatic and manual Battery Test
- Automatic and manual Boost Charge
- Battery current limit adjust
- Deep discharge protection
- Remaining battery time indication
- AC input filter
- AC output filter
- Alarm relay contacts (Standard)
- RS232 communication port (Standard)
- RS485 interface (Optional)
- SNMP adapter (Optional)

- Remote monitoring Panel (Optional)
- RS232 port multiplexer (Optional)
- MODBUS adapter (Optional)
- Diagnostic and adjustment via PC.
- Input and/or output isolation transformers (optional)

**1.2 Design Concept**

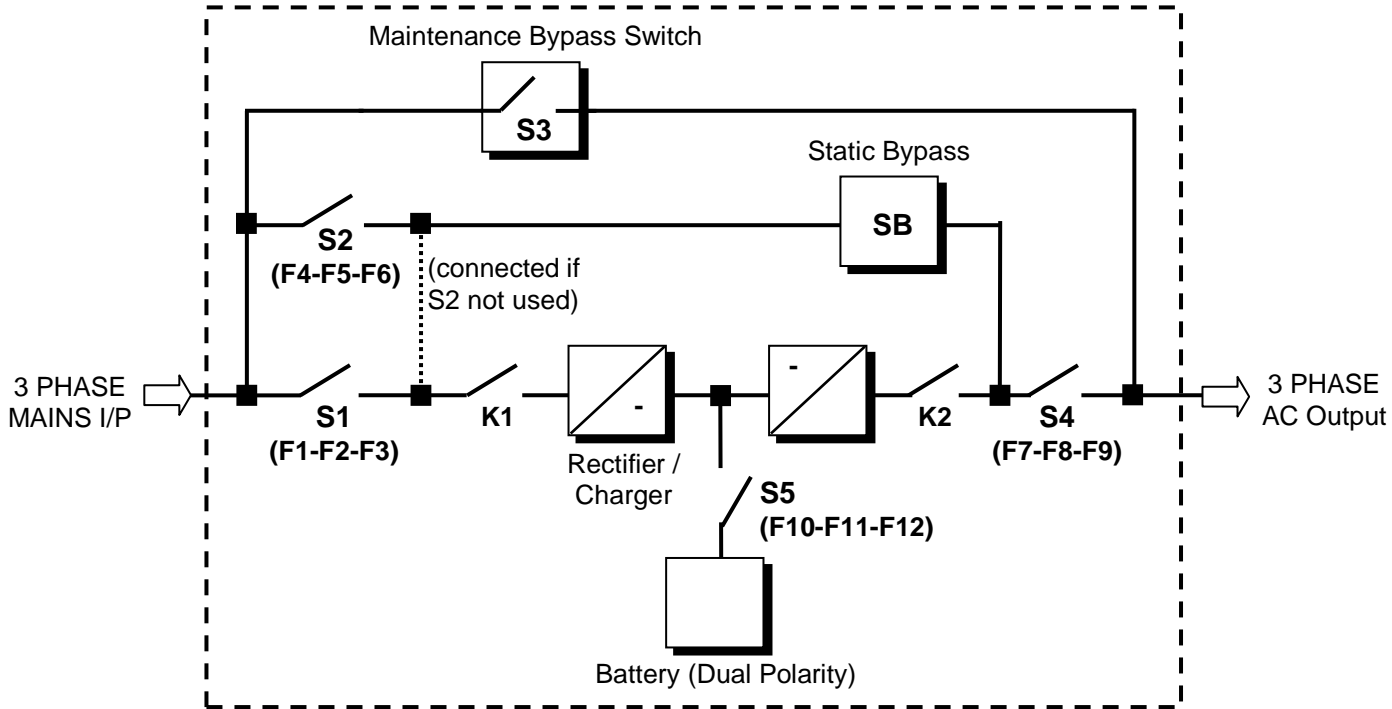

**Figure 1.1 Block Diagram Of The UPS**

- S1 (F1-F2-F3)** : Rectifier Input Switch / Fuses
- S2 (F4-F5-F6)** : Bypass Input Switch (OPTIONAL)
- S3** : Maintenance Bypass Switch
- S4 (F7-F8-F9)** : Output Switch
- S5 (F10-F11-F12)** : Battery Switch (OPTIONAL) / Fuses
- K1** : Rectifier Input Contactor
- K2** : Inverter Output Contactor

**DESCRIPTION OF BLOCKS**

**RECTIFIER:** In CL-300P Series UPSs, a PWM controlled IGBT rectifier is used to increase input power factor (PFC) and to decrease input current harmonics (THDI).

The IGBT rectifier accepts 3-phase AC input and produces a dual polarity DC voltage for both supplying the inverter and charging the batteries.

**BATTERIES:** Batteries are used as reserve DC power supply for the Inverter in case of mains failure. In CL-300P Series, batteries are connected in series with a center-tap output to obtain a dual polarity DC supply. Batteries are discharged by the inverter during mains failure. The discharged batteries are re-charged by the IGBT Rectifier on a constant current / constant voltage basis, if AC mains power is available.

**INVERTER:** It is manufactured by using the latest IGBT technology and Pulse width Modulation (PWM) technique. The Inverter converts the DC BUS voltage supplied by the IGBT Rectifier and / or the batteries into a well regulated 3-phase AC voltage with fixed voltage and frequency.

The output of the inverter is used to supply the critical loads connected to the UPS output.



**STATIC TRANSFER SWITCH (STATIC BYPASS) :** This is an electronically controlled transfer switch, which enables the critical load to be connected either to inverter output or to a by-pass power source. During normal operation, the load is supplied by the inverter output, but in case of an overload it is automatically transferred to the bypass source without any interruption.

**MAINTENANCE BYPASS SWITCH (MBS) :** This is a manually controlled mechanical switch, which is used to supply the critical load, using the bypass source, when the UPS is shut down for maintenance or troubleshooting purposes.

The load is unprotected against mains supply disturbances and black-outs when it is connected to either static or maintenance bypass supply.

**BATTERY SWITCH (OPTIONAL) :** It is connected on the battery inputs of the UPS. This switch is connected after the Battery Input Fuses and used for turning on or off the battery inputs to the UPS.

**ATTENTION : IF A BATTERY SWITCH IS NOT AVAILABLE ON THE UPS, A SEPARATE BATTERY CIRCUIT BREAKER MUST BE USED ON THE BATTERY CABINET.**

### 1.2.1 OPERATING MODES OF UPS

CL300P series UPSs are capable of operating in various different modes for maximum application flexibility. These modes are:

- **ONLINE mode:** This is the normal operation mode for a single UPS. As long as the mains supply is available and in required tolerances, the load is supplied by the well regulated inverter output and the batteries are charged at the same time. In case of mains failure, the inverter keeps supplying the load using the energy stored in the batteries.
- **ECONO mode:** This is the off-line operation mode for a single UPS. As long as the mains supply is available and in required tolerances, the load is supplied by the mains supply (bypass supply) via the Static Bypass Switch of the UPS and the batteries are charged at the same time. During that time inverter keeps running under no-load conditions and takes over the load in case of a mains supply (bypass supply) failure, without any interruption. After restoration of the mains supply the load is transferred back to bypass supply again.
- **PARALLEL, REDUNDANT and N+1 REDUNDANT modes** are used for parallel operation of two or more UPS units and will be explained in parallel operation section later in this manual.

When operating in one of the above operating modes, UPS may be in one of the following operating conditions:

#### **A. Normal Operation (If Mains supply is available):**

All fuses and power switches are closed (except the Maintenance Bypass Switch), and the load is supplied by the Inverter Output. During normal operation, the Rectifier supplies DC power to the Inverter and charges the Batteries at the same time.

#### **B. Battery Operation :**

The Batteries are connected to the Rectifier output. In case of a mains failure (mains power outage or AC input voltage out of tolerance), the Rectifier stops operating and the DC voltage necessary for the inverter operation is supplied by the batteries. Therefore the AC voltage output supplying the critical load is not interrupted, until the batteries are fully discharged. At the end of the discharging time the Inverter is turned off and it start again automatically, together with the Rectifier, when the mains power is restored, and the UPS returns o normal operation.

The Rectifier is also turned off and Inverter operates on batteries during automatic or manual battery test procedure.

#### **C. By-Pass Operation :**

If the Inverter output is overloaded or in case of a problem in the UPS, the static switch transfers the load to the bypass supply without any interruption, provided that the bypass supply is available and within the tolerated limits.

At the end of the overloading period, if the fault condition is restored, static switch transfers the critical load again to the inverter output. Note that, during operation from the bypass supply, the critical load may be effected by any possible disturbances or power failure in the bypass supply.

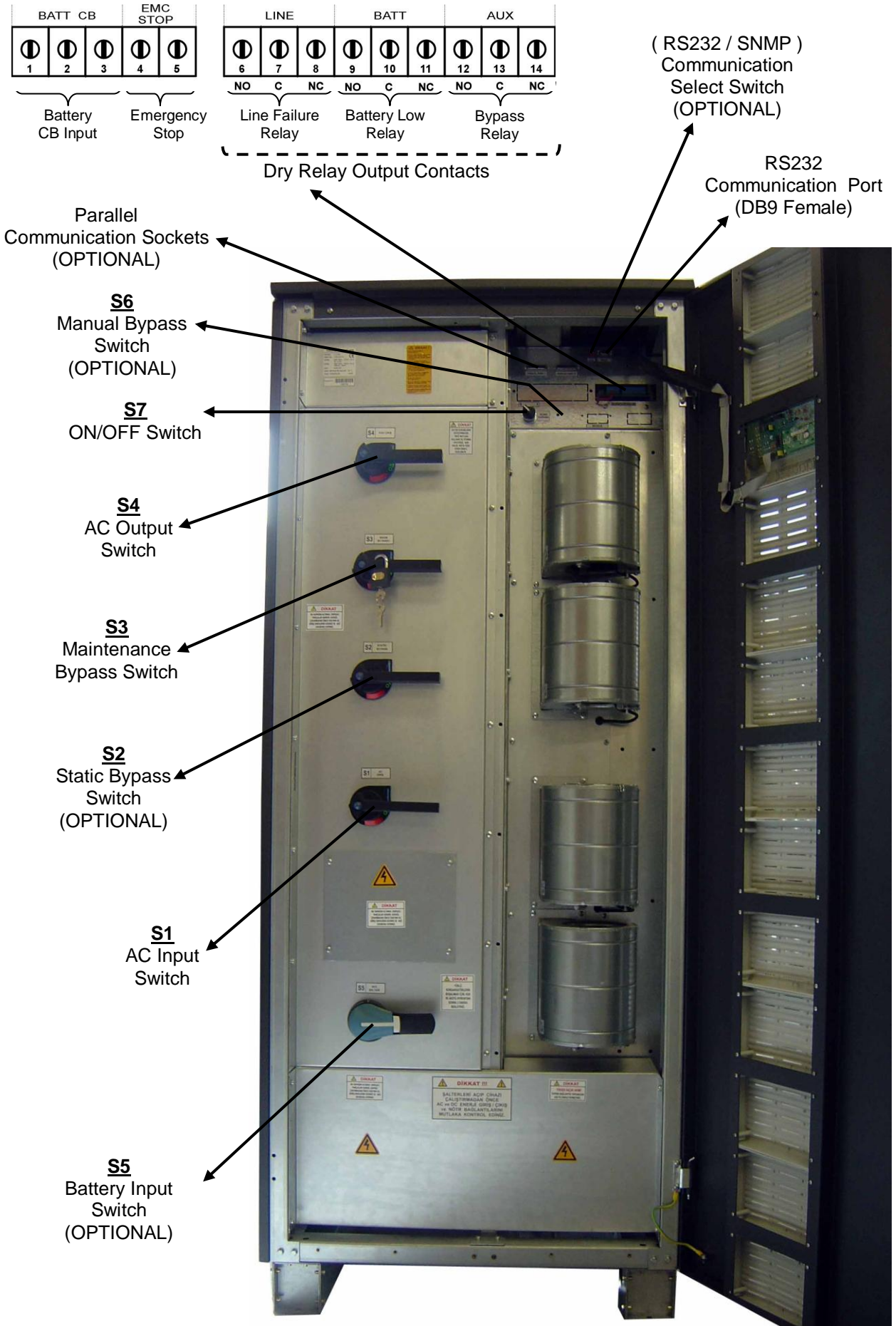

Figure 1.2 100-120-160-200 kVA Switch Configuration

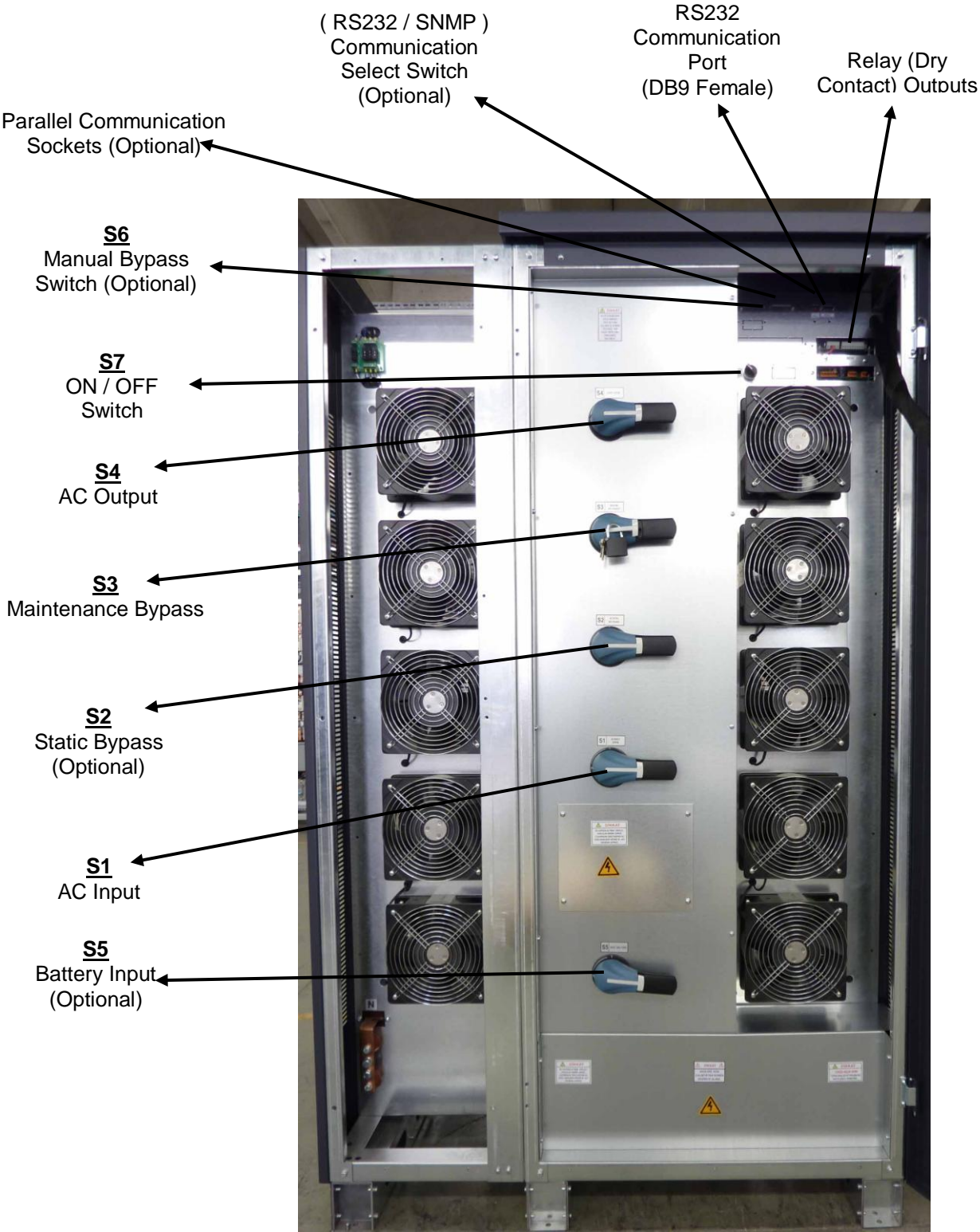

Figure 1.3b 250-300 kVA Switch Configuration

### 1.3 Technical Specifications

MODEL	CL-3100P	CL-3120P	CL-3160P	CL-3200P	CL-3250P	CL-3300P
Output (kVA)	100	120	160	200	250	300
Output (kW)	80	96	128	160	200	240
Output Power Factor	0,8					
<b>INPUT</b>						
Number of Phases	3 Phase + Neutral					
Input Voltage	220/380 Vac , 230/400Vac or 240/415Vac 3phase+N					
Input Voltage Tolerance	+20%,-25% (+15% , -30% for 240/415Vac)					
Input Power Factor (PF)	0,99 (at full load)					
Input THDI	≤ 5 % (at full load)					
Input Frequency	50Hz ± 5 %					
By-pass Voltage	220/380 Vac , 230/400Vac or 240/415Vac 3phase+N					
By-pass Frequency	50Hz					
By-pass Frequency Tolerance	± 2 %					
RFI Level	EN50091					
Split By-pass Connection	Available					
<b>OUTPUT</b>						
Number of phases	3 Phase + Neutral					
Output Voltage	220/380 Vac , 230/400Vac or 240/415Vac 3phase+N					
Output Voltage Tolerance	± 1 %					
Output Frequency	50 Hz					
Output Freq.Tolerance (line synchron)	(± 2 % )					
Output Frequency Tolerance (free running)	± 0,2 %					
Efficiency (at full linear load)	up to 94 %					
Load Crest Factor	3 : 1					
Output Voltage THD	≤ 3 %					
Overload	125% Load 10min. , 150% Load 1min.					
<b>BATTERY</b>						
Total Number	60 (2x30) pieces 12V					
Float Charge Voltage (25 <sup>0</sup> C)	± 405 Vdc					
End of Discharge Voltage	± 300 Vdc					
Battery Cabinet	External					
Battery Test	Automatic and Manual					
Boost Charge	Available					
<b>INTERFACE</b>						
RS 232 Comm. Port	Standard (Optional port multiplexer available)					
RS 485 Comm. Port	Optional					
Remote Monitoring Panel	Optional					
SNMP Adapter	Optional					
Modbus Adapter	Optional					
Alarm Relay Contacts	3x Dry Relay Contacts (Line failure, battery low, bypass)					
EPO Input	Standard					
<b>ENVIRONMENT</b>						
Operating Temperature	0 – 40 <sup>0</sup> C					
Operating Humidity	< 90% (Non-Condensing)					
Acoustic Noise	<70dB	<72dB	<75dB	<75dB	<75dB	<75dB
Dimensions (HxWxD) (mm)	1900x780x890				1900x1150x890	
Protection Class	IP20					
Weight (w/O Batteries) (approx. kgs)	350	375	425	455	576	610

## II. UPS INSTALLATION

### 2.1 Introduction

#### **WARNING!!!**

- Do not apply electrical power to the UPS equipment before the arrival of authorized service personnel.
- **The UPS equipment should be installed only by qualified service personnel.**
- The connection of the batteries and the maintenance should be done by qualified service personnel.
- Do not make any short-circuit to the battery poles. Because of high voltage and high short-circuit current, there is risk of electrical shock or burn.
- Eye protection should be worn to prevent injury from accidental electrical arcs. Remove rings, watches and all metal objects. Only use tools with insulated handles. Wear rubber gloves.

This chapter contains location installation information of the UPS and the batteries. All the establishments have their own specialties and needs. So in this part, the installation procedure is not being explained step by step. Instead, general procedure and the applications are explained for the technical personnel.

### 2.2 Unpacking

The UPS is packed and enclosed in a structural cardboard carton to protect it from damage.

- 1) **Inspect for damage that may have occurred during the shipment. If any damage is noted, call the shipper immediately and retain the shipping carton and the UPS.**
- 2) Carefully open the carton and take the UPS out.
- 3) Retain the carton and packing material for future use.

Unit package contents:

- 1) A user manual and Guarantee certificate.
- 2) Battery cabinet and/or shelf (Optional)
- 3) Battery connection cables.

### 2.3 Equipment Positioning

**ATTENTION: Units are designed to operate on the concrete floor.**

1. The equipment's installation place must be an easy serving place.
2. Install the UPS in a protected area with adequate air flow and free of excessive dust.
3. You must therefore allow for a minimum gap of 800 mm behind the unit to allow adequate air flow
4. Select a suitable place (temperature between 0°C and 40°C) and the relative humidity (%90 max)
5. It is recommended to place the equipment in an air-conditioned the room (24°C)
6. Temperature is a major factor in determining the battery life and capacity. Keep batteries away from main heat sources or main air inlets etc.
7. In case of an operating the UPS in a dusty place, clean the air with a suitable air filtration system.
8. Keep out of your equipment from explosive and flammable items.
9. Avoid direct sunlight, rain, and high humidity.

**WARNING!!! DO NOT LIFT THE BATTERY RACK OR CABINET AFTER THE BATTERIES HAVE BEEN INSTALLED.**

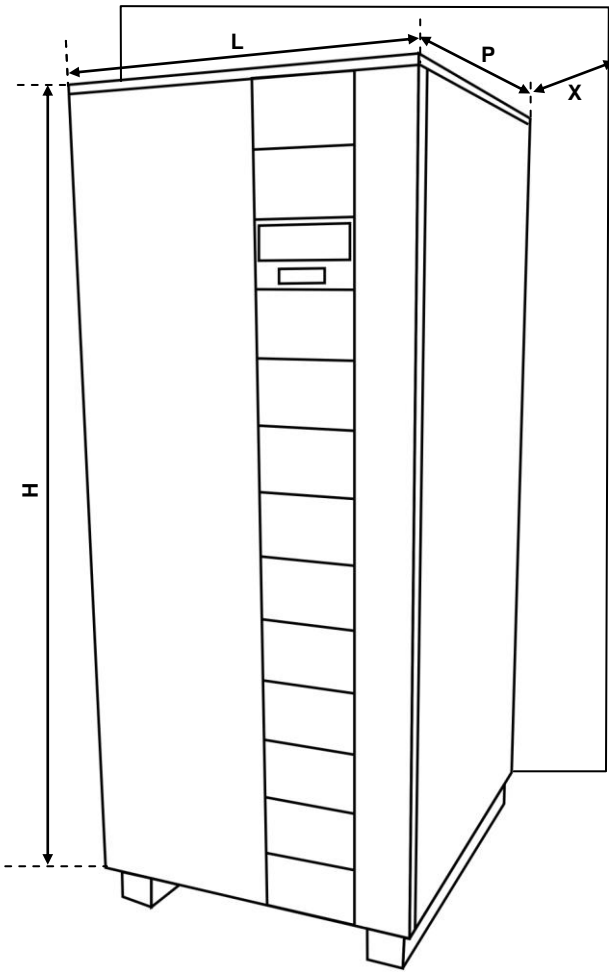

KGK (KVA)	100	120	160	200	250	300
	3 Faz Giriş / Çıkış					
G - mm	780			1150		
D - mm	890					
Y - mm	1900					
X(min.)mm	1000					

Figure 2-1 Installation Diagram

## 2.4 Connecting the UPS Power Cables

**WARNING!!!** A separate power line should be used to supply the UPS AC input. Never use the same line to supply another electrical device. Do not use any additional cable to increase the length of the UPS's input cable. It is advised to use an MCCB suitable for the input current on the UPS's input line.

**The connection of the electrical panel should be supplied by a grounded outlet.**

Otherwise, the UPS and the load connected to the output will be left ungrounded. The grounding system must be checked, and must be strengthened if required. Potential difference between ground and neutral must be less than 3V AC.

Descriptions of the UPS input output cable connection terminals are shown in figure 2.1

Recommended input line cable and fuse ratings are given in the table below.

UPS RATING (KVA)	Recommended cable size (mm <sup>2</sup> )				
	AC INPUT	Bypass INPUT / AC OUTPUT	External Battery INPUT	AC Input /AC Output Cable Terminals U-V-W-N	Battery Terminals + & -
100	50	50	50	M8 bolt	M8 bolt
120	50	50	70	M8 bolt	M8 bolt
160	70	70	70	M8 bolt	M8 bolt
200	90	90	90	M8 bolt	M8 bolt
250	120	120	120	M10 bolt	M10 bolt
300	150	150	150	M10 bolt	M10 bolt

**NOTES** : The neutral conductor should be sized for 1,5 times the output/bypass phase current. These recommendations are for guideline purposes only and are superceded by local regulations and codes of practice.

**WARNING** : **THERE ARE NO INTERNAL FUSES ON THE BYPASS INPUT AND ON THE AC OUTPUT OF THE UPS. THEREFORE, IT IS RECOMMENDED THE USE EXTERNAL FUSES OR MCCBS OF SUITABLE RATINGS BOTH ON THE AC INPUT AND OUTPUT OF THE UPS.**

### 2.4.1 Safety Earth

The safety earth cable must be connected to the earth BUSBAR and bonded to each cabinets in the system and also the earthing and neutral bonding arrangements must be in accordance with the local laws.

**ATTENTION!!!** Failure to follow adequate earthing procedures can result in electric shock hazard to personnel, or the risk of fire.

### 2.4.2 Cable connection procedure

<b>WARNING!!! All connections of the UPS must be done by qualified service personnel</b>
--

After positioning the UPS, the cables must be connected as described below:

1. Verify all switches in front of the UPS are at “0” position. (OFF)
2. Connect the 3 phase AC input coming from the mains distribution panel to the AC input terminals as shown on the label. (Figure 2.2)

**ATTENTION!!!: ENSURE CORRECT PHASE SEQUENCE.**

If there is a phase sequence error, UPS doesn't transfer the load to INVERTER output. If you can't see SYNC:OK in the INFORMATION MENU on LCD, then change the input phase sequence.

3. Connect the output of the UPS to the load distribution panel.
4. Connect the battery groups. Refer to battery installation section.

**WARNING :**

- CHECK BOTH OF THE BATTERY GROUPS FOR CORRECT POLARITY AND VOLTAGE
- DO NOT TURN ON THE BATTERY CB ON THE BATTERY CABINET OR THE BATTERY SWITCH S5 (IF EXISTS) BEFORE STARTING THE UPS

5. Connect the copper earth bus, to the safety earth of the mains distribution panel.

**NOTE :** The earth and the neutral connections must be in accordance with the local rules.

**WARNING :** NEVER TURN ON THE UNIT WITHOUT AN INPUT NEUTRAL CONNECTION (N1).



2.4.3 UPS Power Cable Connection Terminals :

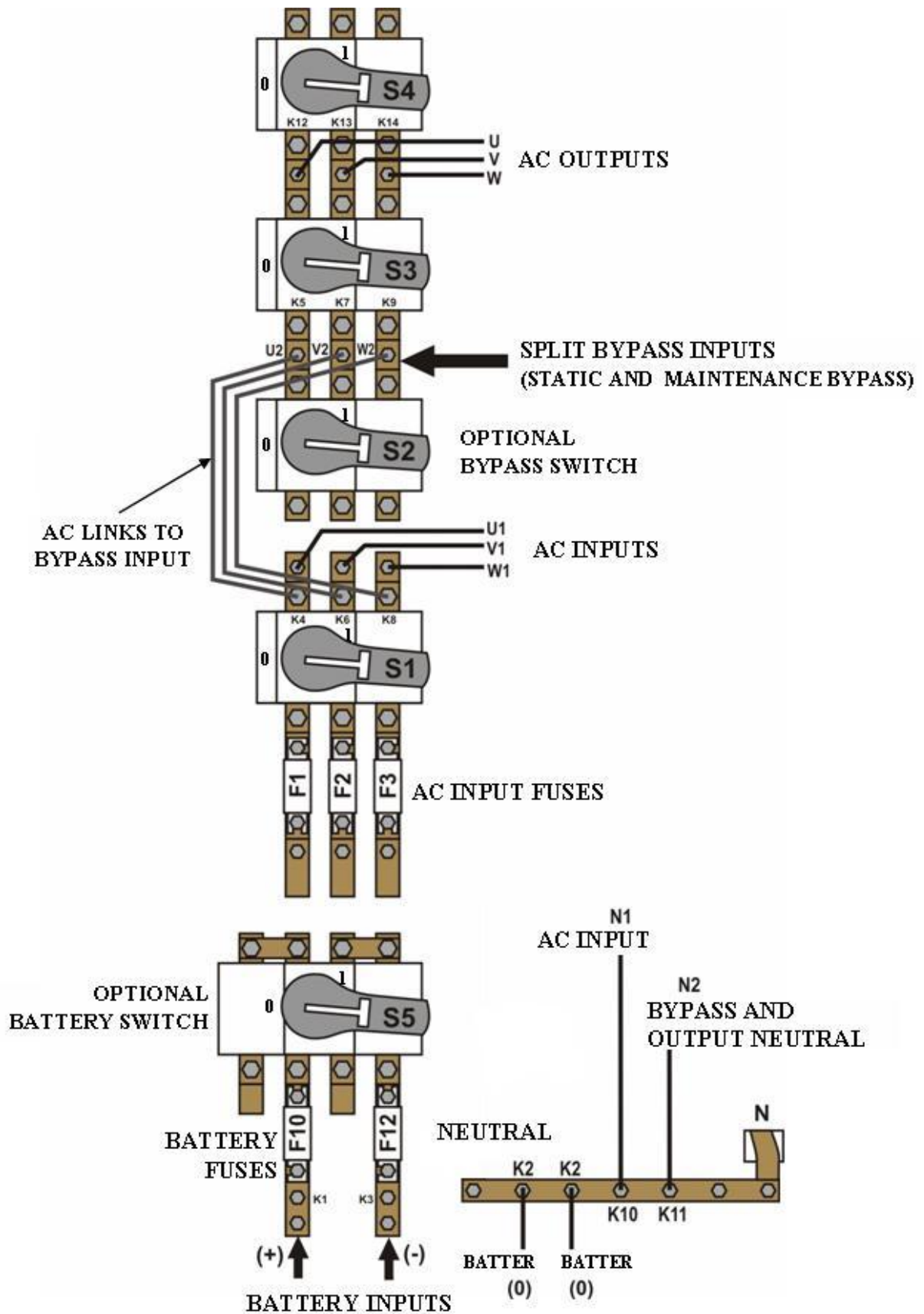

Figure 2.2.a 100-120-160-200-250-300 kVA Power Cable Connections



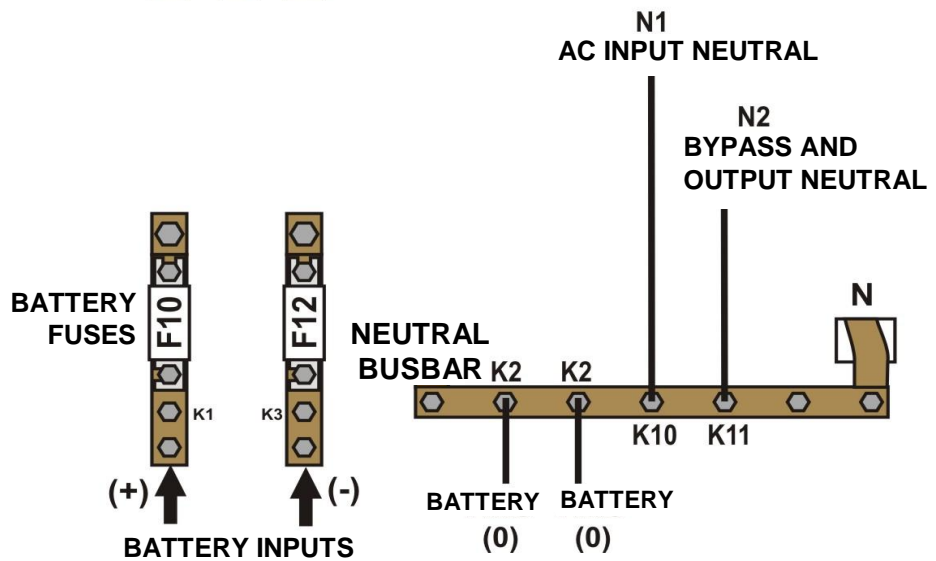
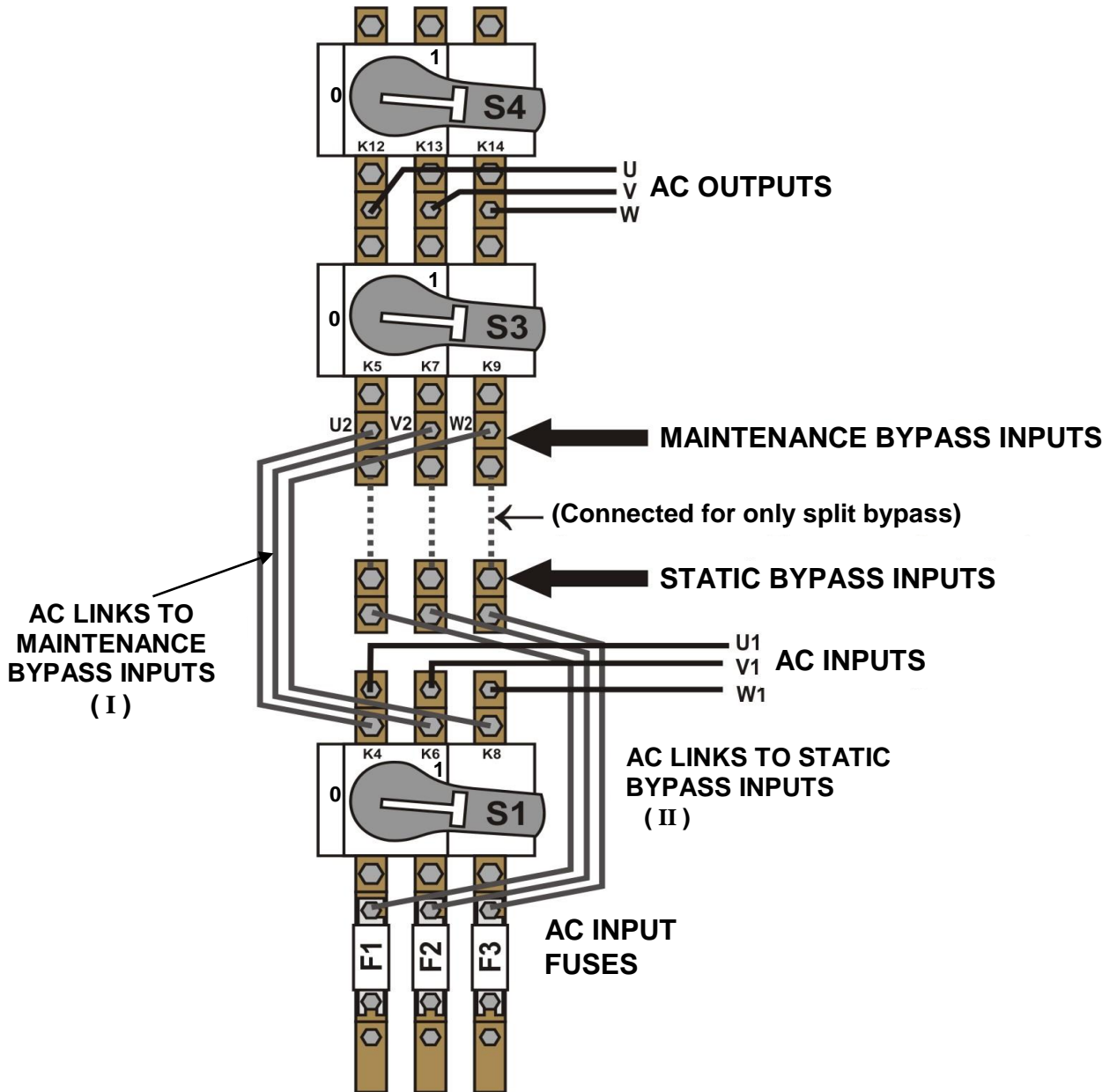

Figure 2.2.b 100-120-160-200-250-300 kVA Power Cable Connections (S5 and S2 are not available)

**NOTES :**

- As shown on the power cable connection diagram of the UPS, U1, V1 and W1 phase of the incoming 3 phase supply are used as the bypass inputs under normal conditions, if there is not a separate bypass supply (split bypass). (U1, V1, W1 and U2, V2, W2 are the same in this case)
- If there is a separate 3- phase AC supply for bypass (Split Bypass):

**IF BYPASS SWITCH S2 AVAILABLE :**

- Remove the links from AC Inputs to Bypass Inputs.
- Connect the phases of the bypass source U2, V2 and W2 to the indicated terminals for Bypass Inputs.
- Connect the Neutral (N2) of the Bypass source to K11. (Neutral Busbar)

**IF BYPASS SWITCH S2 IS NOT AVAILABLE :**

- Remove the links from AC Inputs to Maintenance Bypass Inputs ( I ).
- Remove the AC Links to Static Bypass Inputs ( II ).
- Connect Maintenance Bypass and Static Bypass Inputs to each other as shown by the dashed lines in Figure 2.2.b.
- Connect the phases of the bypass source U2, V2 and W2 to the indicated terminals. (K5, K7, K9)
- Connect the Neutral (N2) of the Bypass Sorce to K11 (Neutral Busbar)

**Note that the Neutral of the 3 phase input supply (N1) and the Neutral of the 3-phase bypass supply (N2) must always be connected together to form the Neutral of the AC output.**

**2.4.4 Battery Installation**

**WARNING !!! Be careful while connecting batteries.**

**ATTENTION !!! NEVER TURN ON THE BATTERY CB ON THE BATTERY CABINET OR THE BATTERY SWITCH (S5), BEFORE STARTING THE UPS AFTER COMPLETING AND CHECKING ALL THE POWER CONNECTIONS.**

The battery racks used for the UPS units should be sited and assembled in accordance with the battery manufacturer's recommendations. In general, batteries require a well-ventilated, clean and dry environment at reasonable temperatures to obtain efficient battery operation.

In general a minimum space of 10 mm must be left on all vertical sides of the battery block. A minimum clearance of 20 mm should be allowed between the cell surface and any walls. All metal racks and cabinets must be earthed.

1. Unpack each battery and check its terminal voltage. Any battery with terminal voltage less than 10,5V must be charged before installation.
2. Please check the battery connecting hardware and documents. (cables, trays, connection diagrams)
3. Please locate suitable number of batteries on each rack, according to the battery installation and connection diagram given with the unit.
4. Start locating the batteries from top to the bottom on the racks.

5. Be careful about the connection between the racks and polarities.
6. After interconnecting the batteries as shown in Figure 2.3 connect "+", "0" and "-" leads of the batteries to the battery input terminals on the UPS. Be careful to connect the batteries correctly and do not turn on (S5) before checking all connections and before starting the UPS. In CL-300P Series UPS, 60 blocks of batteries are connected in series, in such a way that they form two strings of batteries with opposite polarity; with a center tap connection to the NEUTRAL (N1-N2) internally.

**NOTE THAT SEPARATE CABLES FROM EACH BATTERY GROUP SHOULD BE CONNECTED TO K2 TERMINALS ON THE NEUTRAL BUSBAR TO FORM THE MIDPOINT CONNECTION.**

**WARNING!!! NEVER TURN ON THE BATTERY CB ON THE BATTERY CABINET OR S5 (IF EXISTS) WITHOUT CENTER POINT CONNECTION TO NEUTRAL BUSBAR.**

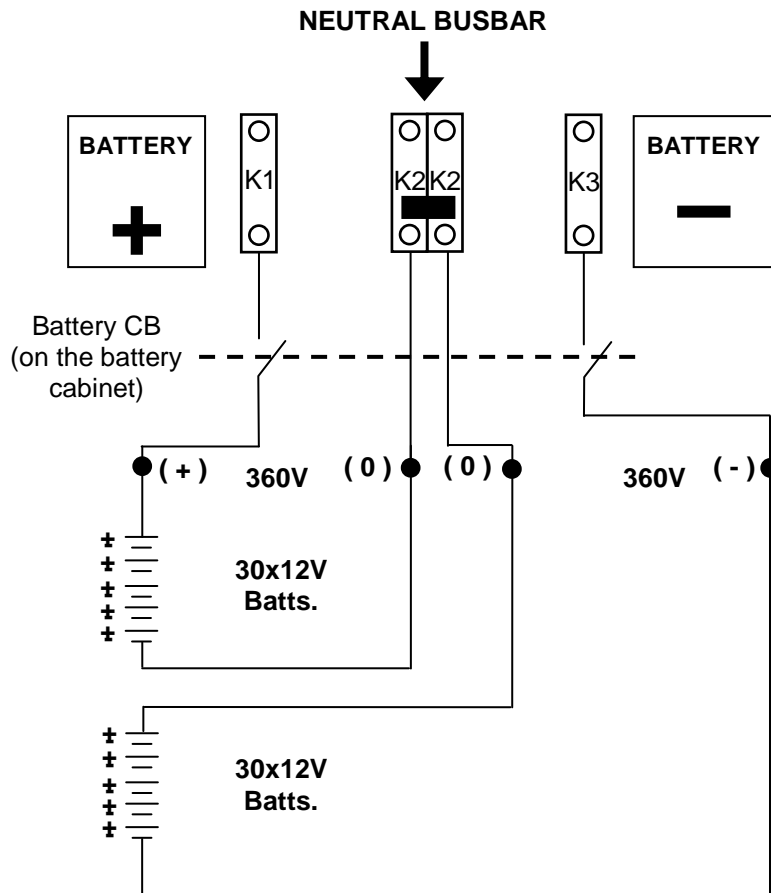

**Figure 2.3** Battery Connections (60x12V)

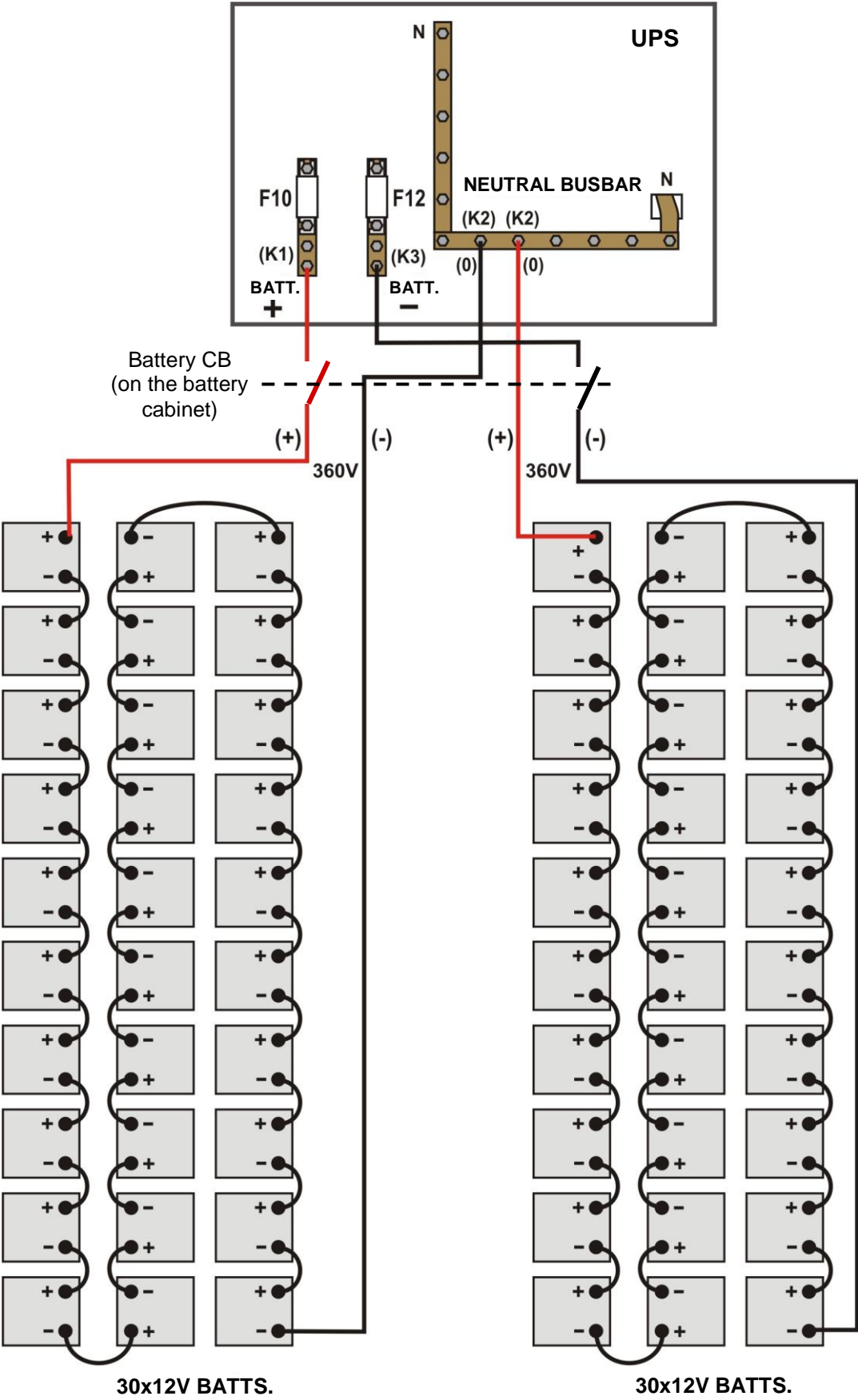
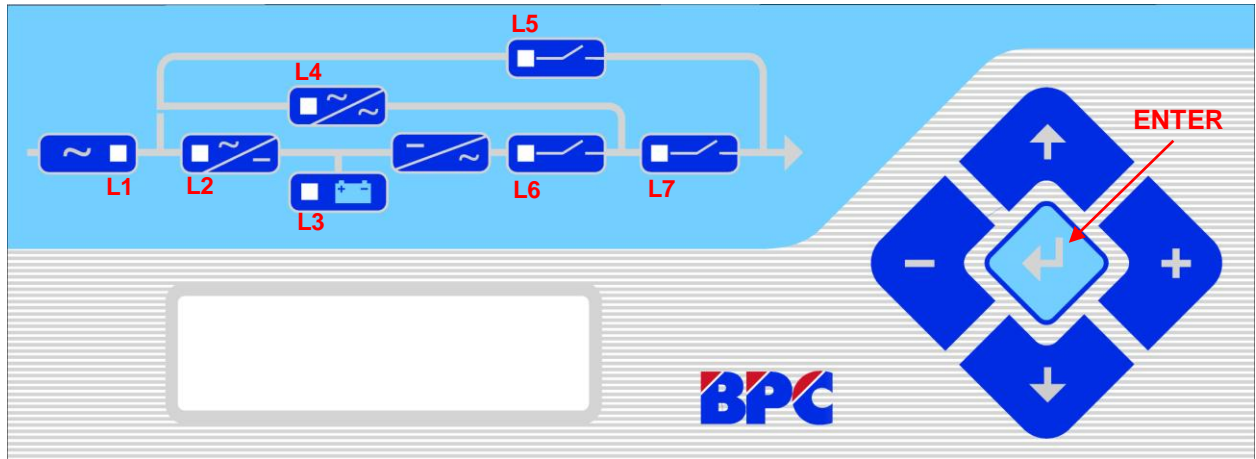

Figure 2.4 CL300P 100-120-160-200-250-300 KVA Battery Connections

### III. FRONT PANEL

#### 3.1 Introduction

The front panel of UPS, consisting of a 2 lines alphanumeric display, 7 status lamps, plus 5 function keys, allows the complete monitoring of the UPS status. The mimic flow diagram helps to comprehend the operating status of the UPS. By using the function keys operator can moves on menus and change some parameters.



**Figure 3. Operator control and indicator panel**

- L1 : If lamp is lit mains is okay
- L2 : If lamp is lit the rectifier is operating
- L3 : If lamp is lit UPS is operating on batteries
- L4 : If lamp is lit static bypass is active and load is supplied by the bypass source.
- L5 : If lamp is lit mechanical bypass switch is on
- L6 : If lamp is lit inverter supplies the load
- L7 : If lamp is lit the output switch is "ON".

There are 5 function keys on front panel. These are ENTER (↵), UP (↑), DOWN (↓), PLUS (+) and MINUS (-). UP and DOWN keys help moving on menus, PLUS and MINUS keys select options, ENTER key means the selected option or menu is valid.

#### 3.2 Front Panel Menu Descriptions

By using the buttons on the front panel, you can move on main menu functions. You can enter the submenus of the item seen on the LCD panel (MEASURES, ALARMS, INFORMATION etc.) and navigate within it by using (↓), (↑) and ENTER keys.

The Main Menu items are listed below. You can choose any requested menu using (↑) and (↓) keys. By pressing ENTER key, you can choose that menu and you can reach all submenu items using (↑) and (↓) keys again. At the end of submenus of each MENU, an <ENTER> EXIT message is seen, and if you press ENTER, you exit from the selected menu and go back to the beginning of the Main Menu.

Main Menu items	Function
<b>STATUS MENU</b>	The status message which shows the UPS status
<b>MEASURES MENU</b>	→ Enter "go to Measures submenu"
<b>ALARMS MENU</b>	→ Enter "go to Alarms submenu"
<b>INFORMATION MENU</b>	→ Enter "go to Information submenu"
<b>ADJUST MENU</b>	→ Enter "go to adjust submenu"
<b>OPTIONS MENU</b>	→ Enter "go to options submenu"
<b>COMMAND MENU</b>	→ Enter "go to Command submenu"
<b>TIME MENU</b>	→ Enter "go to Time and date submenu"
<b>SERVICE MENU</b>	→ Enter "go to service submenu"
<b>Go to STATUS MENU</b>	

### 3.2.1 MEASURES Menu Items

In this menu you can see all measured values. Use (↑) and (↓) keys for moving on submenu items.

	Submenu item	Function
1	LD%: 060 074 080	Output load percentage
2	OPV: 220 221 220	Output voltages
3	FREQU: 50.0 Hz	Output frequency
4	IPV: 240 235 220	Input voltages
5	BYP: 230 232 231	Bypass source voltages
6	IPI: 022 010 030	Input currents (amperes)
7	+BATT: 405 V 000 A	“+” Battery voltage and charge / discharge current
	-BATT: 405 V 000 A	“-” Battery voltage and charge / discharge current
8	TEMP: 030 c	Cabinet inside temperature
9	BATT.CAPACI:068%	Battery charge level
10	ENTER <EXIT>	→ Enter (↓) exit from menu
	Go to STATUS MENU	

### 3.2.2 ALARMS Menu Items

In this menu you can see recorded log events and valid alarms

	Submenu item	Function
1	UPS STATUS	Alarm status at that instant
2	000>311201 23:15	Monitoring past alarms : The first 3 digit number indicates the event number. 000 numbered event is the last event. Date ddmmyy time:hh:mm On the second line of LCD PANEL you can see all recorded alarms. Use PLUS and MINUS keys for moving on events.
3	ENTER CLEAR LOG	→ Enter (↓) clear log event records After you cleared events you see EMPTY LOG message.
4	PARR.ERR.NR : 017	Parallel control board fault number. (if the parallel board is installed) 0 means that there is no error on parallel board
5	ENTER <EXIT>	→ Enter (↓) exit from submenu
	Go to STATUS MENU	

### 3.2.3 INFORMATION Menu Items

This menu gives information about the UPS.

	Submenu item	Function
1	SYNC :OK COMM :OK	If the UPS is operating in synchron to mains SYNC:OK ,if not synchron SYNC:- If communication is active COMM:OK ,if not active COMM:--
2	POWER: 120000 VA	The maximum power rating of the UPS
3	VERSION : B12	Shows the UPS control software version.
4	FREQUENCY : PLL	Frequency generation mode PLL :phase locked loop is generating the frequency SLAVE : in parallel system master is generating the frequency
5	NOM.FRQ: 50 Hertz	Nominal output frequency
6	MODEL: CL310	Model name of the UPS
7	ENTER <EXIT>	→ Enter (↓) exit from submenu
	Go to STATUS MENU	

### 3.2.4 ADJUST Menu Items:

Only service personnel can use this menu ,the incorrect use of this menu can cause damage to the UPS.

	Submenu item	Function
1	<b>PASSWORD : XXX</b>	Service password input (-) key 100, UP key 10, (+) key 1 changes after you write the password on screen press ENTER key ,if the password is wrong the is no action. If the password is okay a beep sounds and you see ADJUST MODE at the second line.
2	<b>ENTER &lt;EXIT&gt;</b>	→ Enter (↵) exit from submenu
	<b>Go to STATUS MENU</b>	

### 3.2.5 OPTIONS Menu Items

In this menu the user can set some important parameters for UPS operation..

	Submenu item	Function
1	<b>MODE: ONLINE</b>	By using (+) and (-) keys you can move on 5 different operation modes. <b>ONLINE</b> : stand alone mode <b>PARALLEL</b> : 2 UPS in symmetric parallel operation <b>N+1 REDUNDANT</b> : 2 or more UPS in N+1 redundant parallel mode <b>REDUNDANT</b> : 2 UPS in redundant parallel mode. <b>ECONO</b> : Off-line mode. → press ENTER for 3 seconds and the selection is valid
2	<b>UPS No : 001</b>	By using PLUS and MINUS keys you can change number 0 to 3. In parallel operation select different number for each UPS. If you select the same number DUBL UPS NUMBER message tells the fault. → press ENTER for 3 seconds and the selection is valid
3	<b>REMOTE :ENABLE</b>	By using PLUS and MINUS keys you can change enable and disable options. <b>Enable</b> : remote battery test, shutdown and bypass functions are enabled <b>disable</b> : these functions are disabled → press ENTER for 3 seconds and the selection is valid
4	<b>RESTART:ON/OFF</b>	By using PLUS and MINUS keys you can change on and off options. <b>ON</b> : during mains failure, at the end of battery discharge UPS shutdowns, and after mains is restored UPS starts again. (battery trip out is on every time) <b>OFF</b> : after mains restoration UPS doesn't start by itself again. (You must turn off and then turn on the UPS) (battery trip out is off) → press ENTER for 3 seconds and then the selection is valid
5	<b>RELAY:BATT.LOW /COMMON</b>	By using (+) key the function of the RL3 Relay on the interface board can be selected between Battery Low or Common Alarm.
6	<b>BATTERY TEST:ON/OFF</b>	By using PLUS and MINUS keys you can change on and off options. Used to enable or disable automatic battery test.
7	<b>ENTER &lt;EXIT&gt;</b>	→ Enter (↵) exit from submenu
	<b>Go to STATUS MENU</b>	

### 3.2.6 COMMAND Menu Items

This menu is used to give various commands, to the UPS or to perform some tests on it. .

	Submenu items	Function
1	<b>SOUND : ON/OFF</b>	Used for turning on/off the audible alarm. If you press ENTER key the option will change (push ON, push OFF) If the OFF option is selected, audible alarm is turned off but in case of a new alarm, UPS changes the option to ON state.
2	<b>ENTER B.TEST&gt;405</b>	If you press enter for 3 seconds battery test starts and lasts for 15 seconds. If battery test fails <b>A6 BATT FAULT</b> message is shown on panel and this message stays until you press ENTER key for 3 seconds. The value on the right indicates the battery voltage during battery test. Starting time of battery test is recorded to log event menu. If the test is performed successfully you can see only <b>BATTERY TEST</b> message on log records. If the test is unsuccessful a <b>BATT.FAULT</b> message will also be recorded. On the bottom line of LCD, <b>BAT FAULT</b> message will stay, and the user will be warned audibly every 15 seconds until this message is cleared by pressing the ENTER key for 3 seconds.
3	<b>ENTER &lt;BYPASS&gt;</b>	If you press ENTER key for 3 the load is transferred to bypass. If the load is on bypass, in this submenu you see <b>ENTER&lt;INVERTER&gt;</b> message at this position. If you press ENTER key for 3 seconds UPS transfers the load on inverter this time. In parallel modes this function is disabled and you see <b>BYP.FUNC.DISABLE</b> message on this submenu item.
4	<b>ENTER:MODEM INIT</b>	If you press ENTER key the connected modem of RS232 port is installed UPS sends AT command set to modem for installation. If the function is completed you must hear a beep sound. At the end of this function modem is ready to answer dial up connection.
5	<b>ENTER &lt;BOOST&gt;</b>	If you press ENTER key for 3 seconds boost charge starts. The given time for boost charge is 10 hours. At the end of this time UPS stops boost charging. If the boost charge is active this submenu item changes to <b>STOP BOOST&gt; 005H</b> message. 005H indicating that boost charge has lasted for 5 hours. If the number is 10, boost charge stops. If you press ENTER key before this time boost charge stops immediately. Boost charge starting and boost charge end times are recorded in log event menu. If boost is active UPS beeps every 15 seconds
6	<b>SIMULATION OFF</b>	The purpose of this submenu is to check dry contact connections. Normally to check line failure contact you must turn off mains power. This is not necessary with this utility. 3 options are available. <b>SIMULATION OFF</b> simulation mode is off <b>SIM: LINE FAILURE</b> if you press ENTER key for 3 seconds, the line failure relay on the interface board is energized. <b>SIM: LIN.F+BT.LOW</b> if you press enter key for 3 seconds line failure and battery low relays are energized. <b>SIM: BYPASS</b> if you press ENTER key for 3 seconds bypass relay is energized. This way, you can check dry contact connections
7	<b>ENTER &lt;EXIT&gt;</b>	→ Enter (↵) exit from submenu
	<b>Go to STATUS MENU</b>	



### 3.2.7 TIME MENU ITEMS

You can see date and time of RTC (real time clock) on UPS. And you can adjust date and time.

	Submenu item	Function
1	TIME : 23 :15	time
2	DATE : 11-10-2006	date
3	SET HOURS: 11	(+) and (-) adjust hours (0-23)
4	SET MINS : 38	(+) and (-) adjust minutes (0-59)
5	SET DAY : 21	(+) and (-) adjust day (1-31)
6	SET MONTH : 06	(+) and (-) adjust month(1-12)
7	SET YEAR : 2006	(+) and (-) adjust year (2000-2099)
8	ENTER <UPDATE>	→ Enter update new date and time
9	ENTER <EXIT>	→ Enter (↵) exit from submenu
	Go to STATUS MENU	

### 3.2.8 SERVICE Menu Items:

	Submenu item	Function
1	HOURMTR: 00027	Total operation time of the UPS
2	MAX.LOAD:095%	Recorded max. load
3	TO B. TEST: 008Hr	Time until next automatic battery test.
4	ENTER <EXIT>	→ Enter (↵) Exit from submenu
	Go to STATUS MENU	

### 3.3 STATUS Messages

This message group simply shows the UPS STATUS on the upper line of LCD PANEL.

**RECTIFIER START !** : UPS started the rectifier  
**INVERTER START !** : UPS started the inverter  
**MAINT SWITCH ON !** : Maintenance bypass switch is on  
**MANUEL BYPASS !** : Load is transferred to mains manually  
**STATUS ALARM !** : Alarm status  
**STATUS NORMAL !** : UPS is operating normally.  
**EMERGENCY STOP !** : External emergency signal is detected.  
**WAITING SYNC !** : Inverter started and waiting for synchronization  
**STATUS FAULT !** : Fault status  
**STATUS WARNING !** : Warning message is valid on LCD panel  
**CLOSE BATT.CB !** : UPS is waiting for battery CB to be closed  
**INV. OUT FAILURE!** : The UPS gave four successive "INV. BALANCE" error.

#### **RECTIFIER START :**

At start up the UPS controller board checks for input voltage, frequency, battery voltage for starting, if these parameters are normal, it starts up.

#### **INVERTER START :**

If the inverter stops by any reason, controller board tries to restart the inverter. Each time the inverter is started, this message appears on the first line of LCD PANEL

#### **MAINT SWITCH ON:**

Maintenance bypass switch is connected from bypass input to the output of UPS directly .If the maintenance bypass switch is on (1 position) controller stops the inverter against any accidental short circuits between mains voltage and inverter output. If the user turns off the maintenance bypass switch, inverter starts again.

#### **EMERGENCY STOP :**

If an external EPO switch is installed to system (connected to interface board), it is possible to stop all UPS parts (rectifier, static bypass, inverter, etc...). After pressing EPO switch, the rectifier and inverter are turned off and the power to the critical load is turned off. To start again, turn off the ON/OFF switch and turn it on again.

#### **FAULT STATUS:**

In some cases controller checks events but can not find solutions, in this case controller decide to stop the system. For restarting the user must turn off the ON/OFF switch and turn it on again.

**WARNING STATUS:**

Some events recorded to log event file stays on LCD PANEL but UPS continues to work, these messages named as warning messages, user can clear this messages by pressing ENTER key for 3 seconds.

These are:

- A20 Boost charge alert
- A6 Charge fault
- A18 Batt capacity low

**3.4 Shutdown messages:**

CL-300P series UPS can operate interactive with the operating system. You can send commands to UPS from operating system by using some softwares .UPS takes these commands and produces some messages listed below:

- WAITING SHUTDOWN** : Shutdown command is performed by the operating system and UPS is waiting for a certain delay for shutdown.
- UPS SHUTDOWN** : UPS is in shutdown status
- WAITING RESTART** : UPS is shutdown but it is waiting for a certain delay for restart
- PAR.SHUTDOWN** : In parallel systems the other UPS sends shutdown command and UPS is in shutdown status.
- CANCEL SHUTDOWN** : Shutdown command is cancelled.

Only operating system or a PC computer can send these commands.

If the shutdown command is performed during line failure UPS shutdowns and if the mains is okay UPS starts again automatically.

**3.5 Fault Messages and Quick Troubleshooting :**

All alarms contained in CL-300P UPS control software are listed in the following table.

ALARM	DESCRIPTION
<b>A1 BYPASS FAILURE</b> <b>Possible Causes:</b>	Bypass system failure Bypass components may be faulty, call service.
<b>A2 INVERTER FAILURE</b> <b>Possible Causes:</b>	Inverter digital start system is failed Internal failure. Call service.
<b>A3 3 OVERTEMP</b> <b>Possible Causes:</b>	Overtemperature in UPS repeated 3 times in the last 30 mins. 1) Check for UPS air inlets and outlets for any blocking by dust etc. 2) Fan failure 3) Bad UPS location 4) Check for Overload
<b>A4 OUT FAILURE</b>	UPS output voltage is out of tolerance for 3 times in the last 30 mins. Internal failure. Call service.
<b>A5 BATT AUT END</b>	Batteries are completely discharged; wait for restoration of electric power input. This message occurs only at the end of a battery operation during line failure.
<b>A6 CHARGER FAULT</b>	Rectifier could not produce DC bus voltage.
<b>A7 BATTERY LOW</b> <b>Possible Causes:</b>	Battery voltage is low. (either positive or negative) 1) UPS operation for long time when line out 2) Charger system failure
<b>A8 OUTPUT HIGH</b> <b>Possible Causes:</b>	Inverter output voltage is higher than the max. tolerated value. Inverter is stopped. 1) Inverter failure

ALARM	DESCRIPTION
<b>A9 OVERLOAD</b> <b>Possible Causes:</b>	UPS loaded more than 100% of nominal power rating. This state is may be continous or temporary. When this alarm is continous check the loads connected to the UPS output.
<b>A10 LINE FAILURE</b> <b>Possible Causes:</b>	Line failure. 1) Mains may be off. 2) Check all three input phases. 3) Check UPS input fuses.
<b>A11 HIGH TEMPER</b>	Overtemperature 1) Overload for inverter 2) Excessive ambient temperature. 3) Fan failure or dirty air inlets 4) Bad UPS location (not enough ventilation)
<b>A12 OVERCURRENT</b>	Inverter output system failure 1) Internal overcurrent 2) Output short circuit. 3) UPS failure. Call the service.
<b>A13 OUTPUT LOW</b>	Inverter output voltage is lower than the min tolerated value. Inverter is stopped.
<b>A14 BATTERY HIGH</b>	Battery voltage is higher than max. tolerated value for batteries. (either positive or negative battery groups)
<b>A15 FUSE FAILURE</b>	Blown fuse(s). (not used in this power range)
<b>A16 BYP INPUT BAD</b>	During transfer to bypass, Voltage or frequency value of bypass source is incorrect and the UPS turns off the load power. During normal (inverter) operation some times you can see this message due to fluctuations in bypass supply. During bypass if the bypass protection option is "ON" and if the bypass source is out of tolerance UPS switches off the static bypass for load protection.
<b>A17 BATT CB OPEN</b>	Battery circuit breaker is off ,batteries are not connected to UPS At start up If the mains is okay you can start operation having this message active. At start up during line failure UPS waits for the battery CB to be turned on and then starts.
<b>A18 BATT.CAPA.LOW</b>	If the battery charge level is low this message indicates that charge period is not completed yet. If mains failure occurs during this message, battery operation time may be unexpectedly short. UPS gives beep sound every 15 sec
<b>A19 BATT FAULT</b> <b>Possible Causes:</b>	Battery test aborted. And batteries are not OKAY UPS gives beep sound every 15 sec You can clear this message by pressing the ENTER key for 3 seconds. 1) Rectifier fault 2) Damaged battery cells 3) Poor battery connections
<b>A20 BOOST CHARGE</b>	Boost charge is active. At the end of the boost charging time UPS stops the boost charge. UPS gives beep sound every 15 sec
<b>A23 MODE FAILURE</b>	In parallel system, the operation mode of the UPS is different from the others.
<b>A24 P.FAILURE 17</b>	Parallel controller board failure
<b>A25 P.FAILURE 18</b>	Parallel controller board failure
<b>A26 P.FAILURE 19</b>	Parallel controller board failure
<b>A27 P.FAILURE 20</b>	Parallel controller board failure

ALARM	DESCRIPTION
A28 P.FAILURE 21	Parallel controller board failure
A29 P.TEST MODE	Parallel controller is in test mode
A30 P FAILURE 23	Parallel controller board failure
A31 DUBL UPS NR. Possible Causes:	Same UPS number is used for two UPS in the parallel system. 1) Change number(s) in OPTIONS Menu.
A39 PSP FAILURE1	Control Power supply fault.
A40 CANT FIND PR	One of parallel modes is selected but there is no parallel control board on UPS Change mode from OPTIONS Menu.
A41 P.BAL.FAILURE	In parallel operation current sharing is not okay
A42 BATTERY TEST	Performing battery test
A43 P.SYNC.FAIL	In parallel system SLAVE UPS is not synchronized to MASTER UPS
A44 BT.OPERATION Possible Causes:	UPS is operating on batteries 1) AC line voltage is not available or out of tolerated voltage limits. 2) Distribution problems or blown fuse(s)
A45 MAINS OK	After mains failure, mains voltage restored again. This message appears on screen for 15 seconds after mains restoration.
A46 BOOST CH.END	Boost charging period has been completed, normal float charging conditions are valid.
A47 CANNOT START	Inverter can not start because of an internal fault.
A52 MANUA. BYPASS	Load transferred to bypass supply from COMMAND MENU
A64 INV. BALANCE	DC balance problem at the Inverter output. Call service.
A65 MAINS HIGH	AC Input Voltage above the tolerated value

Additional Alarm codes for Parallel Operation (Optional).

ALARM	DESCRIPTION
P05 P.SYNC. ALARM	In parallel system SLAVE UPS is not synchronized to MASTER UPS
P07 P.BAL. ALARM	In parallel operation current sharing is not okay (temporary)
P10 P.CLK ALARM	There is an interruption or false status on parallel synchron signal between 2 UPS (temporary)
P16 MODE FAILURE	SLAVE ups search for the same operating mode with MASTER ups, if they are different this message is seen on LCD panel. Change the operation mode of SLAVE ups from OPTIONS MENU. Don't forget to press ENTER key for 3 seconds Turn off the SLAVE ups and turn on again.
P17 RS485 ALARM	There is an interruption or false status in parallel communication between the UPSs
P19 DATA CABLE	Data connection cable between parallel UPS is not OK (bad connection or cable mismatch)
P20 ONLY ONLINE	There is an online UPS in parallel system, please change the operation mode
P21 PLUG IN DIG.	The digital connection cable between parallel UPSs is unplugged
P23 PSP FAILURE 2	Parallel controller board isolated power supply is out
P24 DUBL UPS NR.	Same UPS number is used in parallel system. Change from OPTIONS MENU
P25 NO CLOCK	During power up the synchron clock signal is lost by slave UPS

## IV. PARALLEL OPERATION

### 4.1 Introduction

Two (or more) identical CL-300P series UPSs can be interconnected for parallel operation. The main purposes for parallel use of CL-300P series UPSs are:

- Redundancy for Increased Reliability
- Power Increase

Although recent UPS designs are perfect and have high MTBF figures, a second (or more) UPS can be used in parallel with the first one, for supplying the critical load in case of any possible failure of the first UPS. In such an application the faulty UPS is isolated automatically from the parallel system and the other UPS (or UPSs) continues to supply the critical load. Use of Redundant UPSs in parallel, therefore, provides increased reliability for the critical load connected to the parallel system output.

If power demand increases in a certain UPS application exceeding the power rating of an already installed stand-alone UPS, a second (or more) UPS of the same model and power rating can be added in parallel to the existing UPS to increase the output power capacity.

Schematic diagram of parallel connection of two CL-300P series UPS units is shown in Figure 4.1

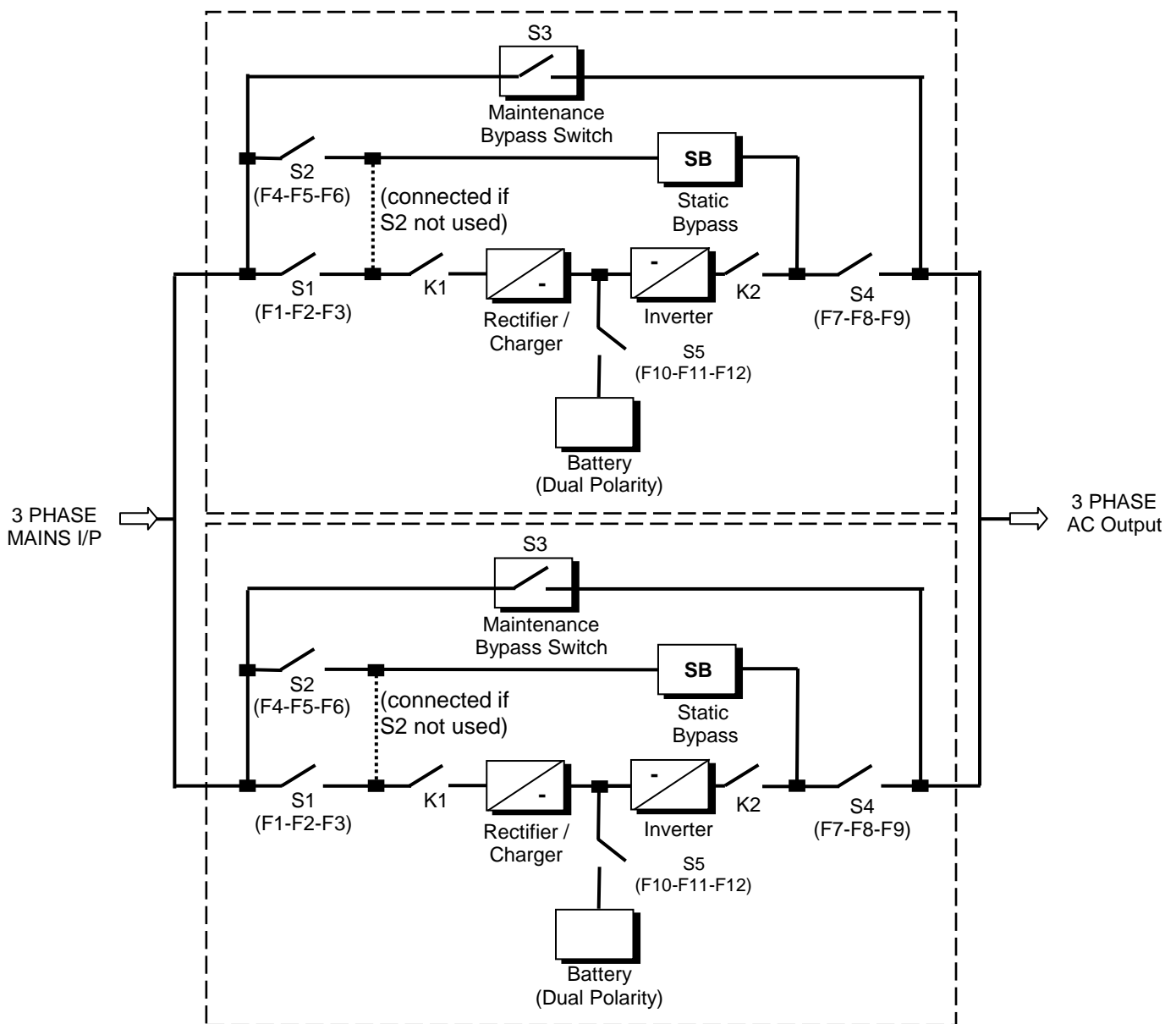

**Figure 4.1** Parallel Connection of two UPSs

The AC inputs of all UPSs in the parallel system are connected to the same mains, and all the AC outputs are connected to each other. Each UPS has its own battery group. The critical load is connected to the common output of the parallel system. There are also some signal cable connections between the UPS units necessary for parallel operation, and will be described later.

## 4.2 Parallel Operation Modes of CL-300P Series UPSs

**NOTE :** Parallel operation hardware (parallel controller boards and some other accessories) are not installed in a standard CL-300P series UPS, but parallel operation option is available and can easily be added to all UPSs.

Parallel operation is possible in one of the three modes:

- 1) PARALLEL operation (power increase)
- 2) REDUNDANT parallel operation
- 3) N+1 REDUNDANT parallel operation

### NOTES:

- 1- The preferred mode for parallel operation can be selected using OPTIONS MENU.
- 2- For parallel operation, each UPS must be assigned a unique UPS No again using OPTIONS MENU.

### 4.2.1. PARALLEL mode

This mode should be selected for increasing the available UPS power capacity. **If this mode is selected for parallel UPS operation, the total VA rating of the parallel system is the sum of the VA ratings of all the UPSs connected in parallel.** The output load is equally shared by each UPS in the parallel system. Mains power is used as the spare energy supply (BYPASS).

In case of a failure in one of the UPSs, the Static Bypass Switches of all UPSs are turned on and the load is transferred totally to the spare energy supply (usually mains voltage) without any interruption. If the fault is cleared and if everything returns to normal operating conditions, the Inverters of all UPSs in the parallel system resume the load together at the same time.

The output load of the parallel system is shared equally by each UPS, both during Inverter or Bypass operation.

If this mode is active, you will see "PARALLEL MODE/MS" on the LCD panel of one of the UPSs, and you will see "PARALLEL MODE/SL" on the LCD panels of all the other UPSs connected in the parallel system (MS meaning Master and SL meaning Slave).

In PARALLEL mode, the Static Bypass Switches of all the UPSs in the parallel system act (turns on or off) simultaneously. During normal PARALLEL operation, the load is shared equally by the inverter outputs of each UPS provided that the output switches of all UPS units are turned on. In case of a failure in one of the UPS units or if the output switch of one of the units is turned off, the static bypass switches of all the parallel units are turned on simultaneously and the critical load is transferred to the bypass supply without any interruption.

**In other words, during operation in PARALLEL mode, the parallel UPS system behaves like a single (stand-alone) UPS with a higher power rating.**

### 4.2.2. REDUNDANT mode

This mode is used for operation of two (or more) UPS units connected in parallel, for increased reliability. If this mode is selected, the load is shared equally by each UPS available in the parallel system, during normal operation.

In case of failure of one (or more) of the UPSs, the faulty UPS is isolated from the parallel system and the critical load is still supplied by the remaining UPSs. If the faulty UPS returns to normal operation, it joins the parallel system again and starts sharing the load.

**In REDUNDANT parallel mode, the total VA rating of the parallel system is equal to the VA rating of a single UPS used in the system.** Only after all the UPS units in the system fail and are isolated from the system, the critical load is transferred to Bypass supply without interruption.

If this mode is active, you will see "REDUNDT. MODE/MS" on the LCD panel of one of the UPS units, and you will see "REDUNDT. MODE/SL" on the LCD panels of all the other UPS units connected in the parallel system.

As explained above, higher degree of reliability for supplying a critical load can be obtained by choosing REDUNDANT mode for parallel operation and using as many as possible parallel connected UPSs.

**4.2.3. N+1 REDUNDANT mode**

This mode is used for operation of at least three (2+1 configuration) UPS units connected in parallel for increased reliability. If this mode is selected, the load is shared equally by each UPS available in the parallel system (N+1 numbers of UPS units), during normal operation.

In case of a failure of any one of the UPS units, the faulty UPS is isolated from the parallel system and the critical load is supplied by the remaining N number of UPSs. If any one of those UPS units fails too, then the critical load is transferred to bypass supply via the static bypass switches of the parallel connected UPSs. If the faulty UPS returns to normal operation, it joins the parallel system again and starts sharing the load.

**In N+1 REDUNDANT parallel mode, the total VA rating of the parallel system is equal to the VA rating of a single UPS multiplied by N.**

If this mode is active, you will see "N+1 REDUNDANT/MS" on the LCD panel of one of the UPS units, and you will see "N+1 REDUNDANT/SL" on the LCD panels of all the other UPS units connected in the parallel system.

More detailed diagrams for two (or more) CL-300P series UPSs connected in parallel are given in Figures 4.2 and 4.3

**Figure 4.2** CL300P Series Parallel UPS Signal Cable Connections

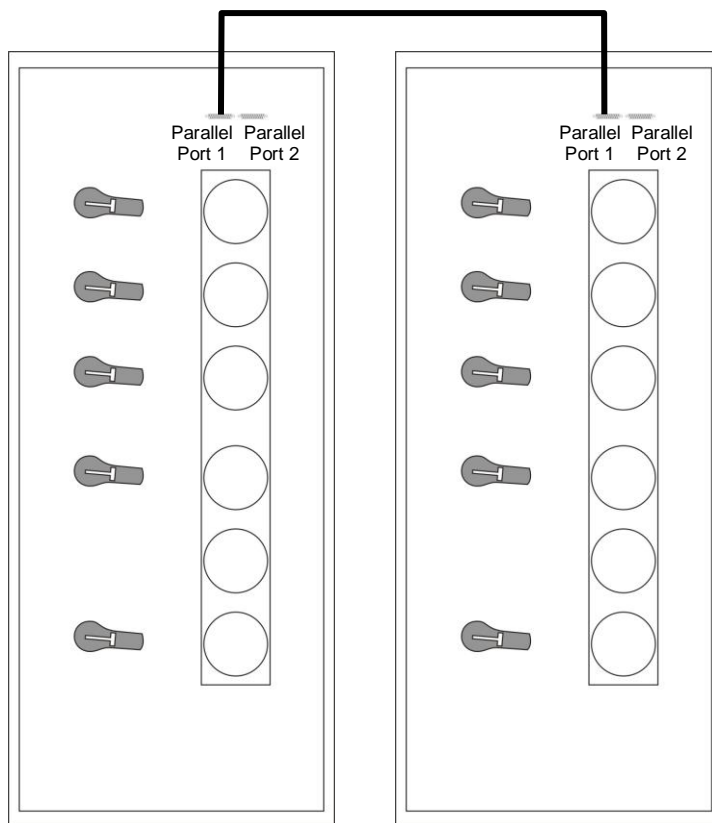

**Figure 4.2.a** 2 units in parallel

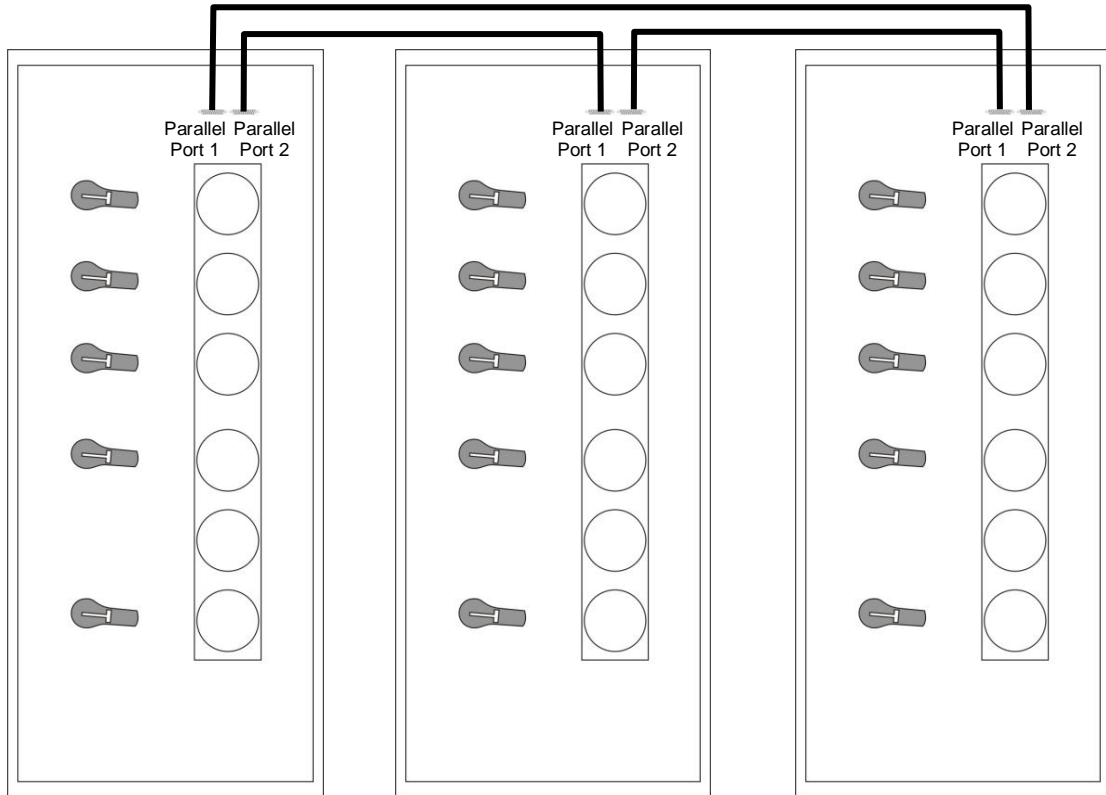

**Figure 4.2.b** 3 units in parallel

**Note:** One purpose-built signal cable (DB25) is provided for each UPS unit in the parallel system. Parallel signal cables are interconnected between the UPS units to form a loop, as shown in figure 4.2, for having higher reliability against any possible signal cable failures.

After completing the parallel connection of all the UPS units as shown in Figures 4.2 and 4.3, turn on each UPS unit one by one and select the operation mode and assign a UPS No, using OPTIONS MENU.

All the units must be set for the **same operation mode** and must have a **different UPS number**.

**CAUTION !!!** You must never set the operation modes of parallel connected UPS units to "ONLINE", otherwise serious damage may occur in UPSs.



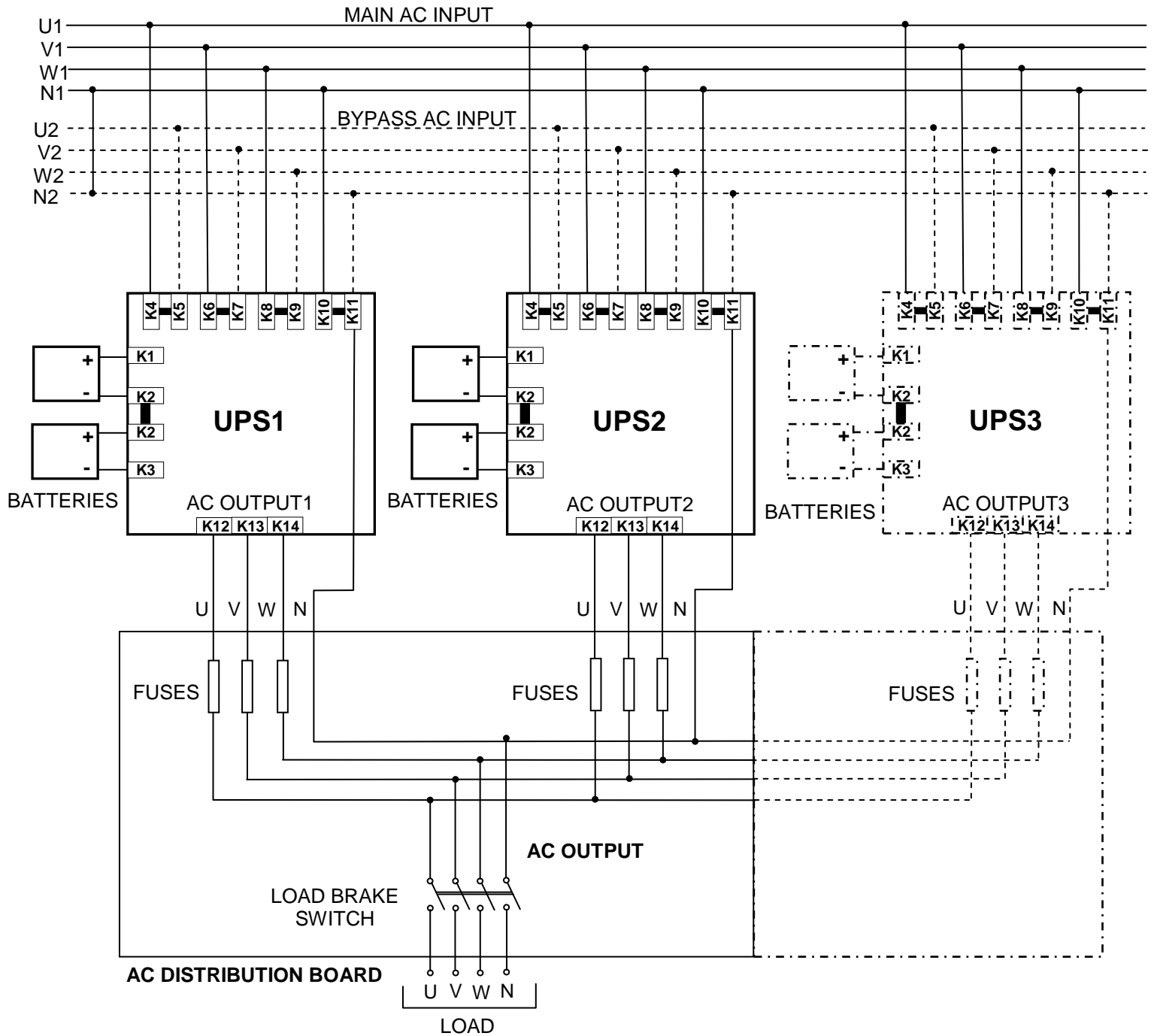

Figure 4.3 CL300P Series Parallel UPS Power Connections

**Note:** As seen in the figure, the outputs of parallel UPS units should be connected to each other using an AC distribution board.

**ATTENTION!!!** The cables from each UPS output to the distribution board must be of the same size and length for proper load sharing during parallel operation.

## V. OPERATING INSTRUCTIONS

### 5.1 INTRODUCTION

After completing the installation of the unit, and connecting all the power cables with all switches and fuses in "OFF" position,

1. Check the battery polarities.
  - K1 : + V (+360V Nominal, +405V under float charge)
  - K2 - K2 (NEUTRAL BUSBAR) : 0 Volts (connected to the midpoint of the 60 blocks battery string)
  - K3 : - V (-360V Nominal, -405V under float charge)
2. Check the 3 phase AC input and neutral connections. (Phase sequence is important)

**NOTE THAT SEPARATE CABLES FROM EACH BATTERY GROUP SHOULD BE CONNECTED TO K2 TERMINALS ON THE NEUTRAL BUSBAR TO FORM THE MIDPOINT CONNECTION!**

**WARNING!!! The UPS must never be turned on without input neutral connection.**

3. Check the output (load) connections.

### 5.2 OPERATING INSTRUCTIONS FOR A SINGLE UPS UNIT. (ONLINE OPERATION)

#### 5.2.1 Procedure For Turning On The UPS To Supply The Load From A Complete Power-Off Condition

1. Turn on S1 (AC Input)
2. Turn on S2 (Bypass)
3. Turn on S4 (AC Output)

**ATTENTION!!! AS SOON AS YOU TURN ON ON/OFF SWITCH (S7), BYPASS VOLTAGE WILL APPEAR THE OUTPUT TERMINALS.**

4. Turn on S7 (ON/OFF Switch), LCD panel will start running. "RECTIFIER START" message will appear on the front panel.
5. When "INVERTER START" appears on the front panel turn on S5 (Battery) into "1" position.

After a few seconds, the BYPASS led L4 (red) will turn off and the INVERTER led L6 (green) will turn on. The UPS is ready for uninterrupted operation when "STATUS NORMAL/ONLINE MODE" message appears on the front panel.

#### 5.2.2 Power Off

After turning off all the loads connected to UPS output:

1. Turn off S4 (AC Output) into "0" position.
2. Turn off S7 (ON/OFF Switch) into "0" position.
3. Turn off S5 (Battery) into "0" position.
4. Turn off S2 (Bypass) into "0" position.
5. Turn off S1 (AC Input) into "0" position.

This is a complete power off condition and both RECTIFIER and INVERTER are not operating in this case.

### 5.2.3 Switching into Maintenance Bypass Mode

1. Use “DOWN” button to choose COMMAND MENU and press ENTER. Use “DOWN” button again to reach ENTER <BYPASS> message. Press ENTER, the UPS will switch into bypass mode. “MANUAL BYPASS” and “A52 MANUA. BYPASS” messages will appear on the screen.
2. Remove the padlock on S3 (Maintenance Bypass Switch) and turn it on into “1” position.
3. Turn off S7, S5, S1, S2 and S4.

Now there is bypass voltage directly on the load, note that there is no AC or DC power in the UPS for maintenance and servicing purposes.

### 5.2.4 Switching From Maintenance Bypass Into Normal Operation

1. Turn on S1 (AC Input)
2. Turn on S2 (Bypass)
3. Turn on S4 (AC Output)
4. Turn on S7 (ON/OFF Switch), LCD panel will start running. “RECTIFIER START” message will appear on the front panel. After the rectifier is started, the inverter will not start and the message MAINT. SW. ON will be seen on the panel instead of INVERTER START.
5. Turn off S3 (Maintenance Bypass Switch) and lock again. The inverter will start automatically.
6. Turn on S5 (Battery).

Now, the UPS is ready for normal operation.

## 5.3 OPERATING INSTRUCTIONS FOR PARALLEL CONNECTED UPSs.

### 5.3.1 Procedure For Turning on the UPS (First Installation)

With all the switches (S1, S2, S3, S4 and S5) in “OFF” (“0”) position and with S6 (static bypass switch) in “NORMAL” position.

**Note:** S6 is the Manual Bypass Switch used in parallel connected UPSs. In parallel UPSs, the “ENTER <BYPASS>” item in the COMMAND menu is disabled and static bypass function is controlled by S6.

Turn on the parallel connected UPS units as follows:

1. Make sure that all signal and power connections have been completed properly according to the diagrams and instructions given before.
2. Turn on S1 (AC Input)
3. Turn on S2 (Bypass)

**ATTENTION!!! NEVER TURN ON S4 (AC Output) BEFORE COMPLETING MODE SELECTION PROCEDURE FOR ALL UPS UNITS.**

4. Turn on S7 (ON/OFF switch) LCD panel starts running and following messages appears on the panel.
  - “RECTIFIER START”
  - “INVERTER START”
5. Using UP-DOWN keys on the front panel, select “OPTIONS MENU” on LCD and press “ENTER”.
 

When you see MODE:\_display, select one of the following parallel operation modes suitable for your application, using “+” and “-“ keys.

  - PARALLEL
  - N+1 REDUNDANT
  - REDUNDANT

After selecting one of the parallel modes, press “ENTER”

6. Again using UP-DOWN and “+”, “-“ keys in the OPTIONS MENU enter a number (0 to 3) for each UPS.

7. Turn off S7 (ON-OFF) and after a few seconds turn it on again. UPS will start running again.
8. When "INVERTER START" message appears on the front panel turn on S5 (Battery) into "1".  
Perform the same procedure given above for all UPS units. **Make sure that all the units have the same operating mode but different UPS numbers.**
9. Turn on S4 (AC Output) switches of all UPSs one by one. Now the parallel UPS system is ready to supply the critical load.

### 5.3.2 Power Off

After turning off all the loads connected to the Parallel UPS System output, apply the following procedure to **all the UPS units** in the parallel system.

1. Turn off S4 (AC Output) into "0" position.
2. Turn off S7 (ON/OFF Switch) into "0" position.
3. Turn off S5 (Battery) into "0" position.
4. Turn off S2 (Bypass) into "0" position.
5. Turn off S1 (AC Input) into "0" position.

This is a complete power off condition and both RECTIFIER and INVERTER are not operating in this case.

### 5.3.3 Switching the Parallel UPS System into Maintenance Bypass Mode (uninterrupted transfer)

1. Switch S6 (static bypass switch for parallel UPSs) of either one of the UPS units into "STATIC BYPASS" position.
2. See that the red-coloured by-pass LEDs (L4) on the front panels of all UPSs are turned on. (Static Bypass Operation)
3. Turn on S3 switches (maintenance bypass) of all UPSs in the parallel system.
4. Turn off S4 switches (AC Output) of all UPS units.
5. Turn off S1 (AC Input) and S2 (Bypass) switches of all UPSs.
6. Turn off S5 (Battery) switches of all the UPS units in the parallel system.

Now all the UPS units which are connected in parallel are completely turned off and the load is supplied by the common Bypass supply via the Maintenance Bypass Switches of all the UPSs.

### 5.3.4 Switching the Parallel UPS system into Normal Operation From a Maintenance Bypass Power Down Condition. (uninterrupted transfer)

**With the S6 switches (static bypass) of at least one of the UPSs, in "STATIC BYPASS" position, turn on all the units as follows:**

1. Turn on S1 (AC Input) switches into "1" position.
2. Turn on S2 (Bypass) switches into "1" position.
3. Turn on S4 (AC Output) switches into "1" position.
4. Turn on S7 (ON-OFF) switches into "1" position.
5. When "MAINT SWITCH ON" message appears on LCD, turn off S3 (Maintenance bypass) switches of all UPSs.
6. Turn on S5 (Battery) into "1" position.
7. Bring S6 (static bypass) switches of all UPS units back to "NORMAL" position.

## VI. MAINTENANCE

**WARNING!!!** DO NOT OPEN the covers of the UPS because there are no user serviceable parts inside. DO NOT TOUCH battery leads. There is high voltage even if the UPS is off. Therefore no one should open the covers of the UPS except authorized service personnel. Otherwise, serious injuries may occur.

### 6.1 Scheduled Maintenance

Some semiconductor devices inside the UPS do not require any maintenance. Cooling fans are the only moving parts. If the environment is clean and cool enough, the scheduled maintenance requirements will be at minimum level. On the other hand, periodic checks and maintenance based on well prepared documents will increase the performance of the UPS and prevent some unimportant faults to become serious ones.

**The equipment has been designed to require minimum maintenance effort. The user should follow the instructions below.**

### 6.2 Daily checks

Check the UPS everyday and be careful about the following:

1. Check the operator control panel. Verify that all LEDs and parameter measurements are normal and there is no alarm message on the indicator panel.
2. Check if the device is overheated.
3. Check the cooling fans' operations.
4. Check if there is any sensible change in the noise level of the equipment.
5. Check if there is any stoppage on the ventilation path. If so, clean the dust using a vacuum cleaner.
6. Make sure that there is nothing placed on the UPS.

### 6.3 Weekly checks

1. Record the results on the indicator panel.
2. Measure and record voltages on each phase.
3. Measure and record currents on the output of the UPS.
4. Check batteries status by performing a manual battery test. Use a dry humid gland to clean the cover of the UPS.

Record the observations if possible. Check if there is any difference with the previous records (observations). If the last recorded values are significantly different from previous records, please check if the load has been changed, and if so please record the type, size, and position of this load. These information will be very valuable in helping the service personal in determining any possible errors.

If there is significant change in the parameter values without any reason please immediately call the qualified service personnel.

## 6.4 Annual maintenance

To get reliable and efficient performance from the UPS, please call the qualified service personal at least once a year.

## 6.5 UPS Storage and transportation

1. Check the batteries charge by performing manual battery test before storage. If the charge is not enough then charge the batteries at least for 12 hours.
2. Qualified service personal should disconnect the electrical connections.
3. Batteries should be charged every six months during storage period.
4. Keep the UPS and batteries in dry and cool place.  
UPS ideal storage temp.: 0 °C ~ 40 °C max.  
Battery ideal storage temp.: 10 °C ~ 35 °C max.
5. The UPS must be placed on a suitable palette for transportation purposes.



## VII. FAULTS AND TROUBLESHOOTING

### 7.1 General Procedure For Fault Checking And Troubleshooting

UPS contains complicated electronic control circuits. In order to locate any fault occurring circuits, an advanced knowledge about the circuitry and its operation principles must be known. The aim of this section is to give the knowledge required at the first intervention.

There is no practical way to locate any possible fault. Most of the faults do not occur as a performance decrement. Generally, the UPS operates normally or switches into by-pass mode. But in order to determine any change in load or the system the parameters must be recorded regularly as mentioned previously.

Generally, the output voltage can deviate %2 from the predefined values. If values differ more than this percentage then reasons must be investigated.

The following general structure must be systematically followed while trying to indicate the error:

**Fault determination:** First step is to record the messages, indicator panel LEDs, operating parameter values and last status of switches. This must be done before

**Fixing interventions:** After recording all indications, check the meaning of the fault and alarm messages using “The operator control indicator panel”. If anything related, follow the related procedure.

**Reporting the fault:** Service personal must clearly report the work done. Hence, if any other error occurs there will be enough information to fix it.

## VIII. UPS REMOTE MONITORING AND CONTROL

Following external connections are available for CL-300P series UPSs.

- Communication by serial port connection.
- Dry contact (interface board) connections.
- Remote monitoring panel.

### 8.1 Using Serial Port

A standard Serial (RS232) communication port is installed to all CL-300P series UPS. By using this port user can get all information about the UPS. All measured parameters and alarms can be monitored via this port. This port is interactive and some commands for UPS operation are available. These commands are listed below.

- Switch to BYPASS
- Switch to INVERTER
- SOUND on/off
- Adjust UPS time and date
- Start SIMULATION mode
- Quick BATTERY TEST
- BATTERY TEST until battery low alarm
- CANCEL battery test
- Turn off UPS output voltage immediately (SHUTDOWN)
- Turn off UPS output voltage after delay (WAITING SHUTDOWN)
- Turn off UPS output voltage (SHUTDOWN) and turn on UPS output voltage (WAITING RESTART)
- CANCEL SHUTDOWN
- RENAME UPS

UPS will give response to these commands only if the **REMOTE: ENABLE** option is selected from **OPTIONS MENU**.

Apply your local distributor, for information on available software for monitoring and controlling the UPS.



Figure 8.

#### 8.1.1 Communication Routing Switch:

RS232 Communication of the UPS can be routed either to an internal (e.g ML100 port multiplexer, MD1 MODBUS adapter, SNMP unit etc.) or to an external device.

There are two sets of DIP switch positions:

	1	2	3	4
INTERNAL (e.g. SNMP)	ON	OFF	ON	OFF
RS232 (EXTERNAL)	OFF	ON	OFF	ON



In “RS232” position of DIP switches, RS232 communication with an external device is performed through the standard DB9 socket shown above. If DIP switches are in “INTERNAL” position, communication through the standard socket is turned off and routed to an internally connected device. For example, if an ML100 Port Multiplexer has been installed in the UPS, standard DB9 socket is not used for RS232 communication, instead, the two ports, COM1 and COM2 on the ML100 can be used for external communication simultaneously.

## 8.2 Serial Communication Cable

The maximum length for RS232 communication cable should be 25 meters. Cable connector pin configuration is as follows:

UPS side	PC side
9 Tx	2 Rx
7 Gnd	5 Gnd
6 Rx	3 Tx

For remote panel and UPS connection the same pin configuration is valid.

## 8.3 Modem Connection

A CL-300P Series UPS can be controlled through a normal telephone line by means of a remote operator connected through a PC with modem device, who performs a phone call to the UPS connected number. So the operator can see all parameters and control the UPS (if permitted from OPTIONS MENU).

### 8.3.1 Hardware Configuration

All requirements for modem connection are as follows:

- PC with modem
- WINDOWS 98
- Available UPS control software (T-MON)
- NULL modem which is connected to UPS

In order to perform this function a PC with UPS control software and an external or internal modem device connected to telephone line are needed.

A NULL modem device, configured according to NULL and auto answer modes, when installed in the UPS and, once programmed, following a telephone call of the PC-embedded modem, will connect the UPS to the telephone line.

### 8.3.2 Functioning Principle

The remote operator, by means of a PC and a modem device and using the remote connection function of the control software, calls the UPS through the number to which this is connected.

The NULL modem device, connected to the UPS, will answer the call and convert the data coming from UPS's serial port on to the telephone line. This way all measurements and controls allowed by the RS232 serial port can be carried out.

### 8.3.3 Modem programming procedure

Smart modem (SM) is the one connected to PC, and NULL Modem (NM) is the one connected to the UPS. Standard Hayes AT programming language is the suitable language for modems. In usual applications a modem which uses AT command set should be selected.

#### 8.3.3.1 SMART Modem Programming (PC modem)

The connected modem to PC (smart modem) will be programmed from UPS control software (T-Mon) automatically.

```
B0 E1 F1 M1 Q0 V1 X3
BAUD = 2400          PARITY = N    WORDLEN = 8
DIAL = TONE          (TONE which can be programmed)
```

```
&A3 &B1 &C1 &D0 &H1 &I0 &K1 &M4
&N0 &R2 &S0 &T5 &Y1
```

#### 8.3.4 Modem –UPS Connection Cable

The connection cable between NULL modem and UPS is configured as follows:

UPS DB9 female	MODEM DB25 male
6	3
7	7
9	2

### 8.4 Dry Contact (Interface) Connections

Some important events of the UPS can be monitored or controlled by these connections. There is a relay for each event, which is located on the interface board. The NC-C-N0 contacts of each Relay are available at the Interface Board output terminals.

These events are:

- LINE FAILURE
- BATTERY LOW
- LOAD ON BYPASS
- BATTERY CB input
- BATTERY CB output
- EMERGENCY STOP input

**ATTENTION: Max. 42VAC or 60VDC voltage should be applied to the dry contact outputs.**

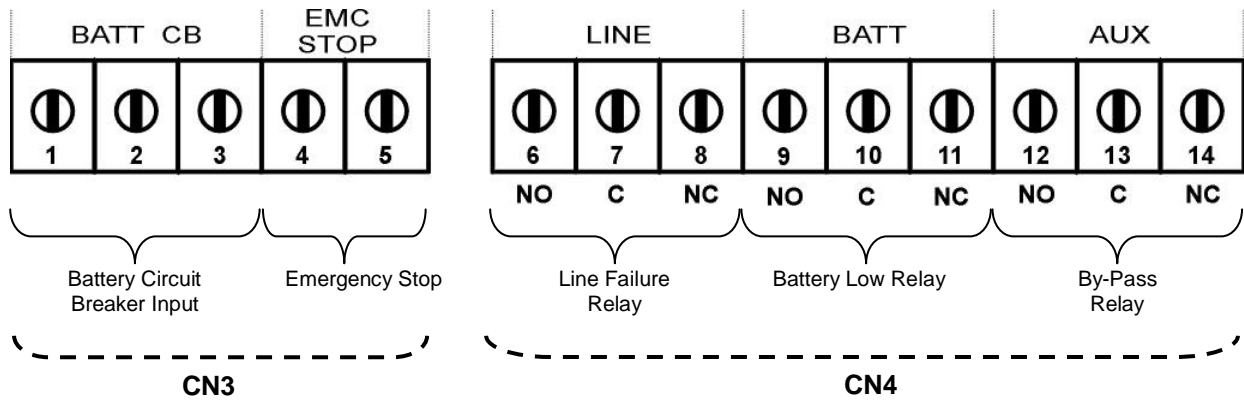

**NOTE:** Emergency stop terminals (4 and 5) should be short circuited by an external EPO switch to apply an EMERGENCY POWER OFF to the UPS (No output voltage).

Line Failure, Battery Low and Bypass relays are normally de-energized and they are energized only in case of an alarm. The behavior of these relays can be reversed by the user. (i.e. all relays are energized normally and de-energized in case of alarm)

### 8.5 Remote Monitoring Panel

Remote monitoring panel can be extended to 400 meters away from UPS. Up to 25 meters there is no need for extra hardware, and RS232 communication is okay. But if the distance is longer than 25 meters additional RS485 hardware is needed.

Up to 5 remote monitoring panels can be used in the system.

AGKK7045 08/2011