

GOODKIT

www.goodkit.com.au

ALL-IN-ONE PORTABLE & RECHARGEABLE SOLAR POWER PACK

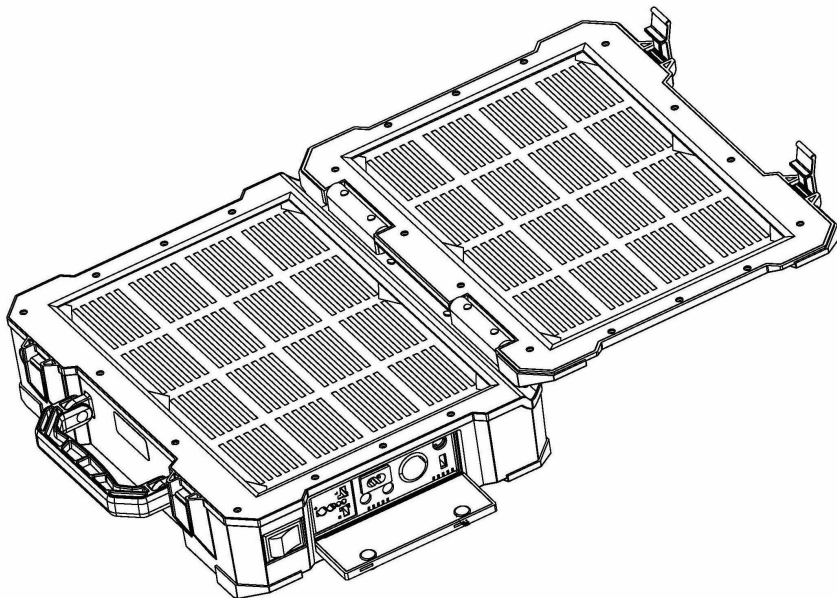

USER MANUAL

Model: VX16

Please read these instructions carefully
and keep for future reference

CONTENT

IMPORTANT SAFETY INSTRUCTION.....	3
INTRODUCTION.....	4
WHAT'S IN THE BOX?	4
PRODUCT DIAGRAM	5
CHARGING / DISCHARGING INTERFACE	5
FEATURES	6
SPECIFICATION	6
OPERATION INSTRUCTION	7
CHARGING YOUR VX16	8
POWERING / CHARGING YOUR DEVICES	9
LED LIGHT	10
MAINTENANCE AND CARE	10
CAUTIONS	10
WARRANTY INFORMATION	11

IMPORTANT SAFETY INSTRUCTION

RISK OF ELECTRIC SHOCK, DO NOT REMOVE THE COVER.

To reduce the risk of electric shock, do not remove the cover. No user serviceable parts inside this unit. Refer servicing to a qualified technician.



The lightning flash with the arrowhead symbol, within an equilateral triangle, is intended to alert the user to the presence of un-insulated 'dangerous voltage' within the products in-closure, that may be of sufficient magnitude to constitute a risk of electric shock.



The exclamation point within an equilateral triangle, is intended to alert the user to the presence of important operating and maintenance (servicing) instruction in the literature accompanying the appliance.

CAUTION: always read and observe all warnings and instructions given in the instruction manual and those marked on the unit.

Read these instructions carefully and keep them in a safe place.

Do not use this appliance near water.

Clean only with a soft dry cloth.

Only use attachments/accessories specified by the manufacturer.

Unplug this unit during lightning storms or when not in use.

Refer all servicing to a qualified service personnel. Servicing is required when the appliance is damaged in anyway.

No object filled with liquids such as vases shall be placed on the appliance.

Do not place naked flame sources such as candles on the appliance.

Make sure all electrical connections are properly made in accordance with the manufacturer's instructions. Switch off and unplug from the mains before changing any connections.

Make sure the mains cord is routed so that it is not likely to be walked on, or subjected to water and heat. Should the power cord need replacing, it must be replaced with a cord of the same type by a qualified technician.

Do not obstruct the vents with such things as newspapers, table cloths, curtains and so on.

Do not operate the appliance if you are in doubt about it working normally, or if it is damaged in any way. Make sure there is adequate ventilation space around the appliance, at least 10 cm at the sides and on the top.

Always unplug from the mains when not in use.

The mains plug should not be obstructed and remain readily accessible during intended use.

The rating markings are located on the base of the unit.

Do not place this equipment in a confined space such as a book case or similar, it must remain in well ventilated conditions. The ventilation should not be impeded by covering the ventilation openings with items such as newspaper, table-clothes curtains etc.

WARNING: Please refer the information on exterior bottom enclosure for electrical and safety information before installing or operating the apparatus.

WARNING: While charging/discharging with power cords, do not expose this apparatus to rain or moisture. The apparatus shall not be exposed to dripping or splashing or objects filled with liquids, such as vases shall not be placed on the apparatus.

WARNING: The battery (battery or batteries or battery pack) shall not be exposed to excessive heat such as direct sunshine, fire or the like.

WARNING: The mains switch is used as the disconnect device, so the disconnect device shall remain readily operable.

INTRODUCTION

Congratulations on the purchase of your VX16, the All-In-One Portable & Rechargeable Solar Power Pack. The VX16 combines leading-edge technology in mono-crystalline photovoltaic and electronics into one portable device to provide you with the best that technology has to offer for your portable charging needs.

- Please read the User's Guide prior to using your VX16.
- Failure to follow the instructions can result in irreparable damage to the device.
- Please keep this User's Guide for future reference.

WHAT'S IN THE BOX?

- a - Good Kit VX16 - Solar Power Pack
- b - AC 220V charging cable
- c - DC 12V charging cable



PRODUCT DIAGRAM

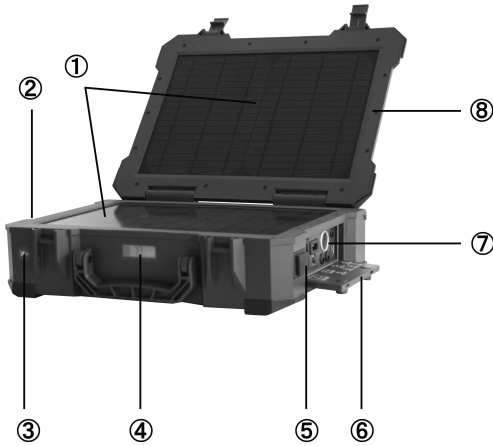

- ① Solar panels
- ② 3W LED bulb
- ③ 3W LED ON/OFF switch
- ④ LCD screen
- ⑤ Master switch
- ⑥ Waterproof safety door
- ⑦ Charging & Discharging interface
- ⑧ Weatherproof rugged construction

CHARGING / DISCHARGING INTERFACE

- Ⓐ AC 220V OUTPUT
- Ⓑ AC 220V INPUT
- Ⓒ DC 12V CAR SOCKET
- Ⓓ DC ON/OFF
- Ⓔ DC 5V USB
- Ⓕ DC 12V OUTPUT (5.5X2.5mm)
- Ⓖ DC 12V OUTPUT (5.5X2.5mm)
- Ⓗ DC 12V~23V INPUT
- Ⓘ AC ON/OFF

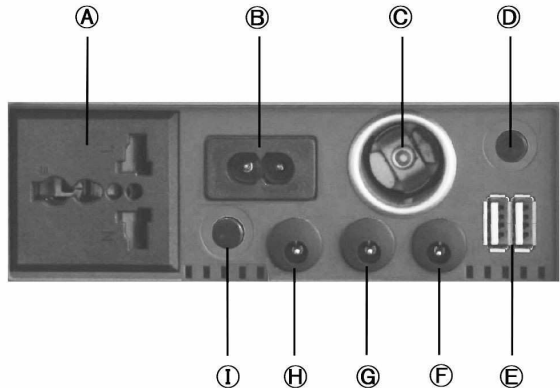

FEATURES

Self-contained portable & rechargeable solar power pack for travel, outdoor activities and emergency/disaster preparedness.

Folding up to a briefcase, your VX16 is lightweight & self-contained with impact-resistant & IP65 waterproof design, the VX16 is a rugged portable & rechargeable solar power source that can convert virtually unlimited supply of solar energy to power many modern technologies and also provide power storage for later use when needed.

AC output for powering/charging multiple devices up to 150W, such as small appliances, lamps, electric fans or TV, 12V car electronics, laptops, tablets, cell phones & other portable gadgets simultaneously.

Charging the built-in 16Ah Lithium Polymer battery indoor or outdoor from:

- 20 watt monocrystalline solar panel
- AC 220V wall socket using power cord included
- DC 12V car cigarette lighter socket using power cord included
- Additional external solar panels not included

Ingress Protection rating IP65 meaning totally protected against dust ingress and protected against low pressure water jets from any direction. Limited ingress permitted.

Universal AC 220V socket that accepts British, NEMA USA, European plug and Australian power plugs.

Built-in super-bright 3 watt white LED bulb with 2 selectable modes, flashlight or SOS beacon light.







Back-lit LCD display with battery strength, input, output and operation status indicators.

SPECIFICATION

Model No.	Good Kit VX16
Waterproof	IP65
Solar panels (Mono-crystalline)	2x10W 14V
Inverter (Pure Sine Wave)	150W AC 220V
Battery (Lithium Polymer)	12V 16Ah
Controller	12V 5A
LED	3W Lighting with SOS feature
Outputs	Universal AC 220V - 1 pc DC 12V (5.5X2.5mm) - 2 pcs DC 12V Car socket - 1pc DC 5V/2A USB - 2 pcs
Inputs	AC 220V - 1 pc DC 12-23V/4A - 1 pc
Dimensions	397*316*106mm
Weight	5.8kg

OPERATION INSTRUCTION

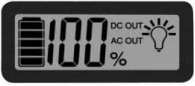
Your VX16 features a blue back-lit LCD status indicator.

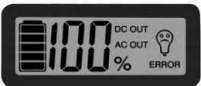
LCD Display	Working state
	POWER OFF
	POWER ON
	AC OUTPUT ON
	DC OUTPUT ON
	AC&DC OUTPUT ON
	AC ERROR
	DC ERROR
	AC&DC ERROR

There are three ways to charge your VX16.

SOLAR CHARGING

The VX16 can be charged by using the power of the Sun. Open your VX16 and for best results, place it in direct sunlight. The battery capacity on ④ LCD display will start going up. Make sure ① the solar panel can get as much sunlight as possible.

You can add additional solar panels (Max.50W) by connecting them through ⑨ DC 12V~23V INPUT connector and putting them under direct sunlight, to charge the VX16 faster (not included).

After the ④ LCD display shows the battery 100% full please close the VX16 and / or disconnect additional solar panels to protect the battery.

The 16Ah internal backup battery will take about 16 hours to fully charge.

In cloudy conditions, VX16 may take approximately 2 times longer to charge than the above mentioned times, but this is depending on the time of year, density of cloud etc.

If charging from behind the glass, it will increase the time needed to charge, sometimes up to three times longer than if outside.

AC CHARGING

The VX16 can be charged by any standard AC 220V wall outlet using the included (b) AC charging cable. Connect (b) charging cable to VX16 in to ⑥ the AC 220V INPUT and plug the other end into any standard AC wall outlet to begin charging. The battery capacity on ④ LCD display will start going up. After ④ the LCD display shows the battery 100% full disconnect the charging cable to protect the battery.

The 16Ah internal backup battery will take about 3 hours to fully charge.

DC CHARGING

Your VX16 can be charged by car DC 12V cigarette socket using the included (c) DC charging cable.

Connect (c) charging cable to VX16 in to the ⑨ DC 12V-23V INPUT and plug the other end into DC 12V car cigarette socket to begin charging. The battery capacity on ④ LCD display will start going up.

After the ④ LCD display shows the battery 100% full, disconnect the charging cable to protect the battery.

The 16Ah internal backup battery will take about 3 hours to fully charge.

Approx. Charging Time

Approx. charging time	Battery capacity	12V 16Ah
Charging method		
AC Charging		3 hours
DC Charging		3,5 - 6 hours
20W solar charge		16 + hours

POWERING / CHARGING YOUR DEVICES

Turn ⑤ the master switch ON.

To use AC press the ① AC ON/OFF button to turn it ON.

Connect AC 220V device to ④ AC 220V OUTPUT socket, make sure the load power is no bigger than 150W. Recommended continuous power load is 120W. Simply plug in your device in to ④ AC 220V OUTPUT socket. After finishing powering/charging, disconnect the device from the VX16 and press the ① AC ON/OFF button to turn off the AC power.

To use DC press the ② DC ON/OFF button to turn it ON.

Connect DC 12V device to ③ or ⑥ or ⑦ DC 12V OUTPUT socket, make sure the load power is no bigger than 60W.

After finishing powering/charging, disconnect the device from the VX16 and press the ② DC ON/OFF button to turn off the DC power.

⑤ The Universal USB power ports allows you to charge mobile devices such as iPod®, iPhone®, iPad®, Zune®, Samsung® and other devices which require special proprietary OEM cables. Simply connect your OEM USB cable to your device and to the VX16 as described in the steps above.

You can use AC & DC power at the same time, but make sure the load power does not exceed the limits.

Sample Items VX16 Can Power On a Full Charge

Sample Items	Power Load	Quantity	Cumulative Daily Working Hours	Daily Power Consumption	Continued Working days
CFL Bulb	15W	2	4	120Wh	1.3 Days
LED bulb	3W	4	4	48Wh	3.3 Days
LCD TV(22 inch)	25W	1	3	75Wh	2.1 Days
Small laptop	30W	1	2	60Wh	2.7 Days
Inkjet printer	30W	1	0.5	15Wh	10.7 Days
Tablet	10W	1	5	50Wh	3.2 Days
Fan	15W	1	4	60Wh	2.6 Days
Radio	3W	1	6	18Wh	9 Days
Cell phone	2.5W	2	8	40Wh	4 Days
Hand vacuum	80W	1	2	160Wh	1 Day
Satellite Phone	12W	1	2	24Wh	6.7 Days
GPS	4W	1	4	16Wh	10 Days

Multiple Items Can Be Powered Simultaneously

LED LIGHT

The VX16 is equipped with a side-loaded ② LED light. It can be used as a torch, reading light, emergency backup light, for camping and more. Simply press the ③ LED switch to turn ON the light. Press it again to switch ON the SOS mode. By pressing it third time the LED light will be turned OFF.

When battery fully charged, continues working time of LED light is approx. 53 hours.

Avoid direct eye contact with the LED light during operation. Prolonged exposure to a high-intensity light source may cause eye damage.

MAINTENANCE AND CARE

Wipe the exterior surface with a damp cloth and dry thoroughly with a soft dry cloth prior to use.

Do not use abrasive or volatile cleaning compounds.

For the best results, please ensure that the solar cell is free from any dust or debris that may impede direct sunlight exposure.

For long term storage, ensure the unit is placed in a cool dry indoor location.

Recharge your VX16 every 3 months when not in use.

CAUTIONS

Check the voltage of your device before connecting with your VX16.

Do not use any AC devices above 150W to prevent damage to the inverter contained within your VX16.

Do not use any DC devices above 60W to prevent damage to the VX16.

Keep in a safe place free from dust, liquid and extreme temperatures.

Do not store and operate VX16 outside of the following temperature range: from -5°C to 45 °C.

Keep out of reach of small children.

When not in use, please disconnect from power sources.

Do not drop or apply excessive pressure to the solar panels.

Do not use sharp objects near the solar panels to avoid damage.

Do not attempt to repair the unit, always contact technical support if you experience any faults.



This unit contains a Li-Polymer 12V 16Ah battery.

Do not dispose of this product in your household waste. Contact your local authority for details of local recycling schemes. Batteries should not be disposed of in household waste. Batteries should be taken to appropriate disposal points or alternatively contact your local authority for details on disposal schemes.

WARRANTY INFORMATION

Your Good Kit product is supplied with a 12 month warranty from the date of purchase against defects in material and workmanship under normal use and service. Should your product prove defective within 1 year from the date of purchase, return the device product, freight prepaid along with a copy of the proof of purchase and an explanation of the claim to Good Kit.

Good Kit does not accept liability for any 3rd party damage how so ever caused or any costs associated with the return of faulty products.

Under this warranty Good Kit will replace or repair any parts found to be defective due to manufacturers defect. This warranty extends only to personal use and does not extend to any product that has been used for commercial use, rental use, or use which is not intended. There are no warranties other than that expressly set forth herein. This warranty is not transferable.

Good Kit is not responsible in any way for damages, losses, or inconveniences cost by equipment failure or by user negligence, abuse, or use in not accordance with the "User Manual" or any other additional safety, use, or warnings included in the product materials.

Further, Good Kit is not liable for incidental, data loss, or consequential damages of any nature resulting from the use of this product and any liability shall not exceed the purchase price of the product.

These warranty conditions in no way affect your statutory rights. A full set of Good Kit warranty conditions and terms and conditions are available on request.

For questions or warranty related inquiries, please contact us at: support@goodkit.com.au

