

# **HD IR Waterproof Fixed Network Camera**

## **User's Manual**

Model No. K-EW114L03E

K-EW114L06E

K-EW114L08E

## **Welcome**

Thank you for purchasing our network camera!

This user's manual is designed to be a reference tool for your system.

Please read the following safeguard and warnings carefully before you use this series product!

Please keep this user's manual well for future reference!

# Important Safeguards and Warnings

## 1 . Electrical safety

All installation and operation here should conform to your local electrical safety codes.

The power shall conform to the requirement in the SELV (Safety Extra Low Voltage) and the Limited power source is rated DC12V in the IEC60950-1. (Refer to general introduction)

**Please note: Do not connect two power supplying sources to the device at the same time; it may result in device damage!**

We assume no liability or responsibility for all the fires or electrical shock caused by improper handling or installation.

We are not liable for any problems caused by unauthorized modification or attempted repair.

## 2 . Transportation security

Heavy stress, violent vibration or water splash are not allowed during transportation, storage and installation.

## 3 . Installation

Do not apply power to the camera before completing installation.

Please install the proper power cut-off device during the installation connection.

Always follow the instruction guide the manufacturer recommended.

## 4 . Qualified engineers needed

All the examination and repair work should be done by the qualified service engineers.

We are not liable for any problems caused by unauthorized modifications or attempted repair.

## 5 . Environment

This series network camera should be installed in a cool, dry place away from direct sunlight, inflammable, explosive substances and etc.

Please keep it away from the electromagnetic radiation object and environment.

Please make sure the CCD (CMOS) component is out of the radiation of the laser beam device.

Otherwise it may result in CCD (CMOS) optical component damage.

Please keep the sound ventilation.

Thunder-proof device is recommended to be adopted to better prevent thunder.

## 6. Daily Maintenance

Please shut down the device and then unplug the power cable before you begin daily maintenance work.

Do not touch the CCD (CMOS) optic component. You can use the blower to clean the dust on the lens surface.

Always use the dry soft cloth to clean the device. If there is too much dust, please use the water to dilute the mild detergent first and then use it to clean the device. Finally use the dry cloth to clean the device.

Please put the dustproof cap to protect the CCD (CMOS) component when you do not use the camera. Dome enclosure is the optical component, do not touch the enclosure when you are installing the device or clean the enclosure when you are doing maintenance work. Please use professional optical clean method to clean the enclosure. Improper enclosure clean method (such as use cloth) may result in poor IR effect of camera with IR function.

## 7. Accessories

Be sure to use all the accessories recommended by manufacturer.

Before installation, please open the package and check all the components are included.

Contact your local retailer ASAP if something is broken in your package.

Accessory Name	Amount
Network Camera Unit	1
Quick Start Guide	1
Installation Accessories Bag	1
CD	1
Important Safety Instructions	1

# Table of Contents

1	General Introduction .....	1
1.1	Overview .....	1
1.2	Features .....	1
1.3	Specifications .....	2
2	Structure .....	4
2.1	Multiple-function Combination Cable .....	4
2.2	Framework and Dimension .....	5
3	Device Installation .....	6
4	Quick Configuration Tool .....	8
4.1	Overview .....	8
4.2	Operation .....	8
5	Web Operation .....	10
5.1	Network Connection .....	10
5.2	Login and Main Interface .....	10
6	FAQ .....	12

# 1 General Introduction

## 1.1 Overview

This series network camera integrates the traditional camera and network video technology. It adopts video data collection, transmission together. It can connect to the network directly without any auxiliary device.

This series network camera uses standard H.264 video compression technology, which maximally guarantees the video quality.

It supports the IR night vision function. In the night environments, the device can use the IR light to highlight the object which is suitable for the surveillance function in the low illumination environments. The waterproof design conforms to the IP 66 level. It has the sound waterproof function suitable for use in the outdoor environments.

It can be used alone or used in a network area. When it is used lonely, you can connect it to the network and then use a network client-end. Due to its multiple functions and various uses, this series network camera is widely used in many environments such office, bank, road monitor and etc.

## 1.2 Features

<b>User Management</b>	<ul style="list-style-type: none"><li>● Different user rights for each group, one user belongs to one group.</li><li>● The user right shall not exceed the group right.</li></ul>
<b>Storage Function</b>	<ul style="list-style-type: none"><li>● Support central server backup function in accordance with your configuration and setup in alarm or schedule setting</li><li>● Support record via Web and the recorded file are storage in the client-end PC.</li><li>● Support network storage function such as FTP.</li></ul>
<b>Data Transmission</b>	<ul style="list-style-type: none"><li>● Data transmission via PoE.</li></ul>
<b>Network Monitor</b>	<ul style="list-style-type: none"><li>● It supports one-channel video data transmit to network terminal and then decode. Delaying time is within 270ms (network bandwidth support needed)</li><li>● Max supports 20 connections and output bandwidth is 32Mbps. System refuses new connection request once it exceeds the bandwidth threshold.</li><li>● Adopt the following video transmission protocol: HTTP, TCP, UDP, MULTICAST, RTP/RTCP, RTSP and etc.</li><li>● Support web access.</li></ul>
<b>Network Management</b>	<ul style="list-style-type: none"><li>● Realize network camera configuration and management via Ethernet.</li><li>● Support device management via web or client-end.</li><li>● Support various protocols.</li></ul>
<b>Power</b>	<ul style="list-style-type: none"><li>● External power adapter DC 12V.</li><li>● Support PoE. (Please refer to specifications.)</li></ul> <p><b>Warning!</b> <b>Do not connect these two power supplying sources to the device at the same time; it may result in device damage!</b></p>
<b>Assistant Function</b>	<ul style="list-style-type: none"><li>● Log function</li><li>● Support VMD.</li><li>● Support system resource information and running status real-time display.</li><li>● Day/Night mode auto switch.</li><li>● Support picture parameter setup such as electronic shutter and gain setup.</li><li>● Backlight compensation: screen auto split to realize backlight compensation to adjust the bright.</li></ul>

	<ul style="list-style-type: none"> <li>● Support digital WDR.</li> <li>● Support video watermark function to avoid vicious video modification.</li> <li>● Built-in IR light. Support IR night vision.</li> <li>● The enclosure conforms to the IP 66 protection. Has the waterproof function</li> <li>● Support dual bit streams, ACF.</li> </ul>
--	---

### 1.3 Specifications

Please refer to the following sheet for network camera performance specification.

Parameter		Model	K-EW114L03E	K-EW114L06E	K-EW114L08E
System	Main Processor	High performance DSP			
	OS	Embedded LINUX			
	System Resources	Support real-time network, local record, and remote operation at the same time.			
	User Interface	Remote operation interface such as WEB, Mobile-EMS, EMS			
	System Status	Bit stream statistics, log, and software version.			
Video Parameter	Image Sensor Pixel	1/3 " CMOS			
		1280(H) × 960(V)			
	Day/Night Mode	Support day/night switch			
	Gain Control	Manual/Auto			
	White Balance	Manual/Auto			
	BLC	On/Off			
	Exposure Mode	Auto/Low noise/Low motion blur/Manual It ranges from 1/3 to 1/100000.			
	Video Compression Standard	H264/MJPEG			
	Video Frame Rate	Stream(1)(1280*960@30fps), Stream(2)(704*480@30fps)			
	Video Bit Rate	H.264: 32Kbps-8192Kbps. MJPEG is adjustable and bit rate is adjustable. Support customized setup.			
	Video Flip	Support mirror. Support flip function.			
	Snapshot	Max 1f/s snapshot. File extension name is JPEG.			
	Privacy Mask	Supports max 4 privacy mask zones			
	Video Setup	Support parameter setup such as bright, contrast.			
	Video Information	Channel title, time title, VMD, camera masking.			
Lens	3.6mm Fixed focus	6mm Fixed focus	8mm Fixed focus		
Lens Interface	M12. Lens is the default accessories				
Video	VMD	396 (18*22) detection zones; sensitivity level ranges from 0 to 100; area threshold ranges from 0 to 100. Activation event: video storage, image snapshot, log, email function and etc			

Backup and Record	Record Priority	Manual>video detect>schedule
	Storage Management	Network storage
Network	Wire Network	1-channel wire Ethernet port, 10/100 Base-T Ethernet
	Network Protocol	IPv4/IPv6, HTTP, HTTPS, SSL, TCP/IP, UDP, UPnP, ICMP, IGMP, SNMP, RTSP, RTP, SMTP, NTP, DHCP, DNS, PPPOE, DDNS, FTP, IP Filter, QoS, Bonjour
	Remote Operation	Monitor, system setup, file download, log information, maintenance , upgrade and etc
	Restore Default Setup	Reset button
	IR light	IR light 30M.
General Parameter	Power	DC 12V power and PoE. <b>Warning !</b> <b>Do not connect these two power supplying sources to the device at the same time; it may result in device damage!</b>
	Power Consumption	DC12V 420mA PoE DC48V 110mA
	Working Temperature	-20°C~+60°C
	Working Humidify	≤95%
	Dimensions(mm)	70×66×160
	Weight	500g (Excluding box)
	Installation	Bracket installation



## 2 Structure

### 2.1 Multiple-function Combination Cable

You can refer to the following figure for multiple-function combination cable information. See Figure 2-1.

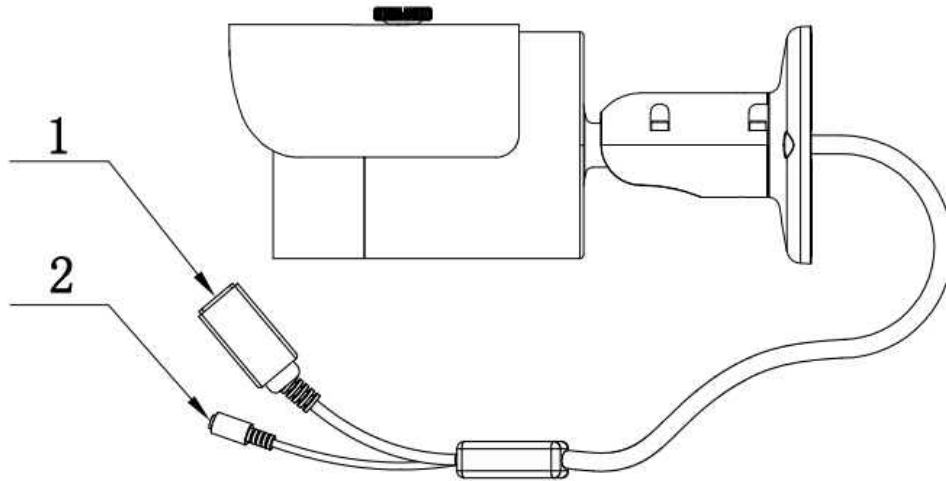

Figure 2-1 Multiple-function combination cable

No.	Port Name	Function	Connection	Note
1.	LAN	Network port	Ethernet	Connect to standard Ethernet cable.
2	DC12V	Power input port		Power input port. Input DC 12V.

## 2.2 Framework and Dimension

Please refer to the following two figures for dimension information. The unit is mm. See Figure 2-2 and Figure 2-3.

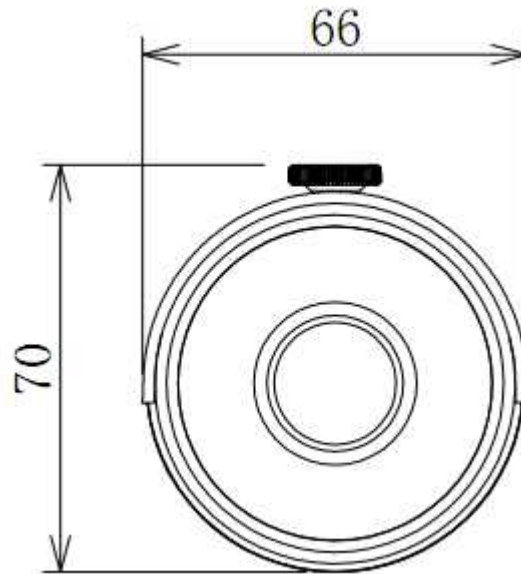

Figure 2-2 Dimension illustration 1

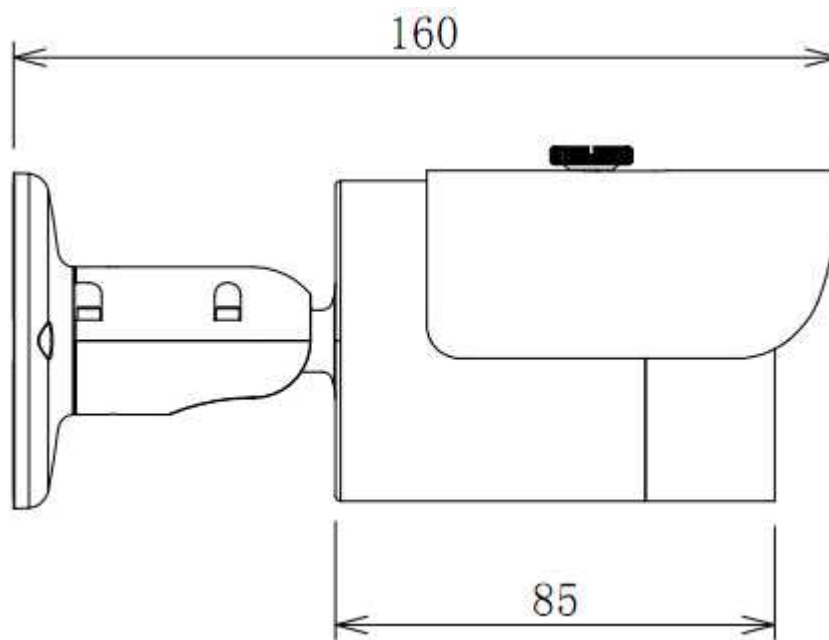

Figure 2-3 Dimension illustration 2

### 3 Device Installation

#### Important

- Make sure that the installation area is strong enough to hold the product, such as a concrete ceiling.
- Install the camera in the foundation area of the architecture or where sufficient strength is assured.
- If a wall or ceiling board such as plasterboard is too weak to support the total weight, the area shall be sufficiently reinforced.

Please see Figure 3-1 and Figure 3-2.

#### Step 1

Stick installation sticker to designated surface where you will install the device (wall or ceiling).

#### Step 2

Affix the installation template label (accessory) to the ceiling or wall, and use a pen to mark the positions of the screws and cable mounting hole in the ceiling or wall. Remove the installation template label and attach the camera with 3 screws (locally procured).

#### Step 3

Plug external wiring of the device properly.

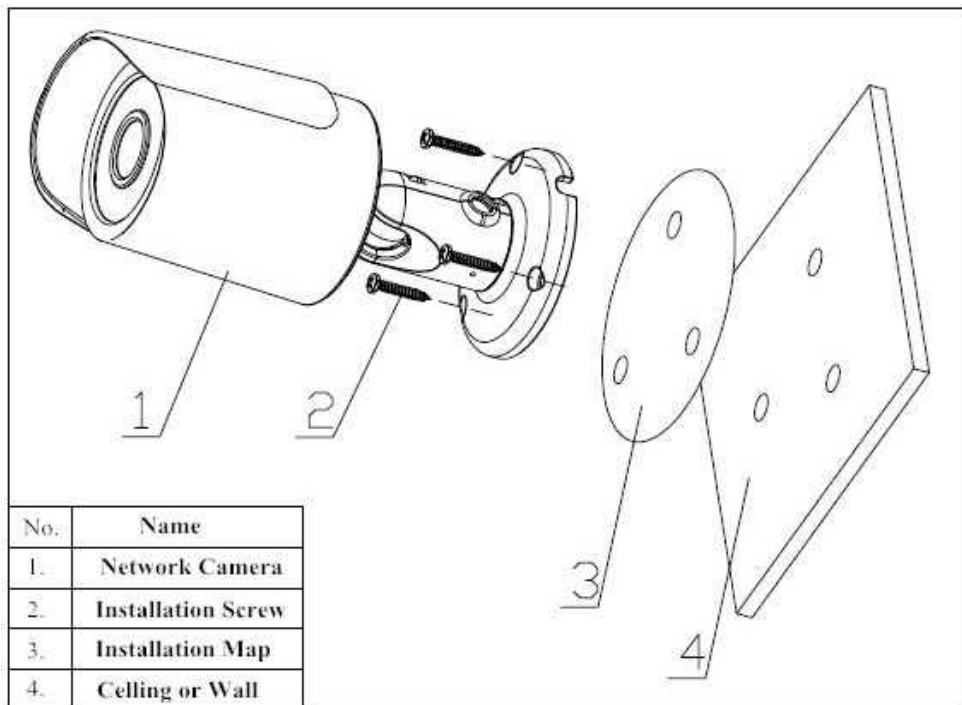

Figure 3-1 Device installation 1

#### Step 4

Use Philip's head screw (in accessories bag) to loosen adjusting screw.

#### Step 5

Adjust the device in all possible directions, and set its monitoring direction.

#### Step 6

Use Philip's head screw to tighten the screws

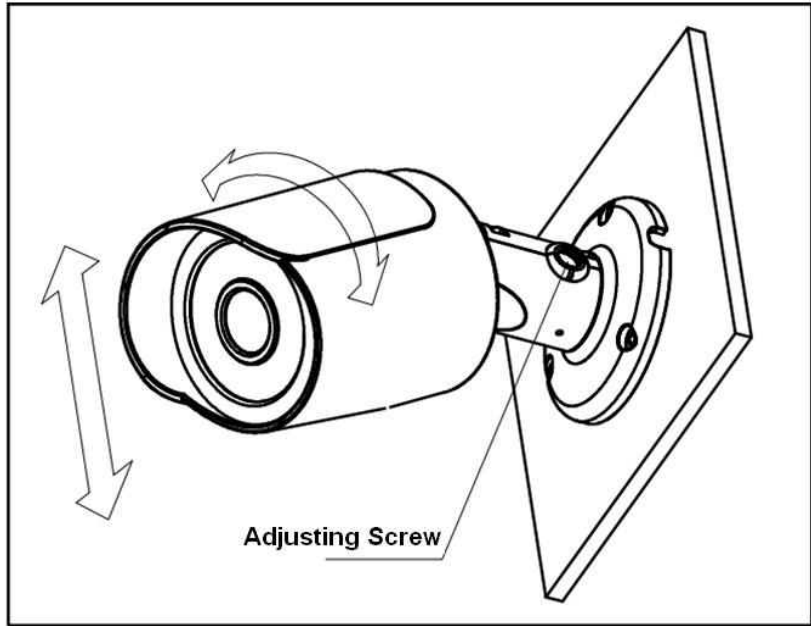

Figure 3-2 Device installation 2

## 4 Quick Configuration Tool

### 4.1 Overview

Quick configuration tool can search current IP address, modify IP address. At the same time, you can use it to upgrade the device.

Please note the tool only applies to the IP addresses in the same segment.

### 4.2 Operation

Double click the “ConfigTools.exe” icon, you can see an interface is shown as in Figure 4-1.

In the device list interface, you can view device IP address, port number, subnet mask, default gateway, MAC address and etc.

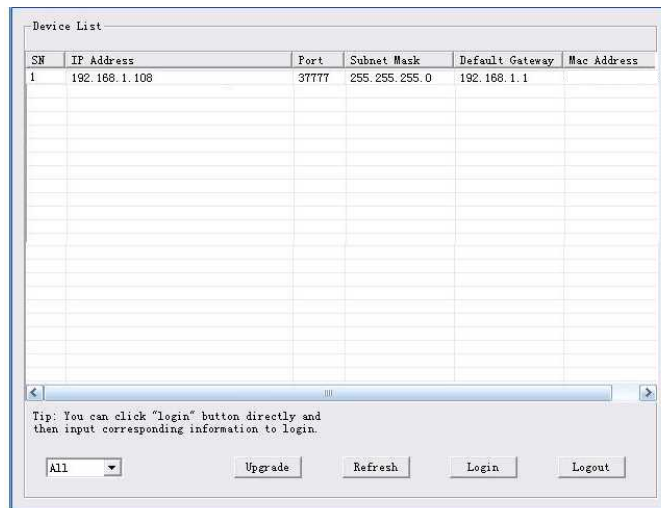

Figure 4-1 Search interface 1

Select one IP address and then right click mouse, you can see an interface is shown as in Figure 4-2. Select the “Open Device Web” item; you can go to the corresponding web login interface.

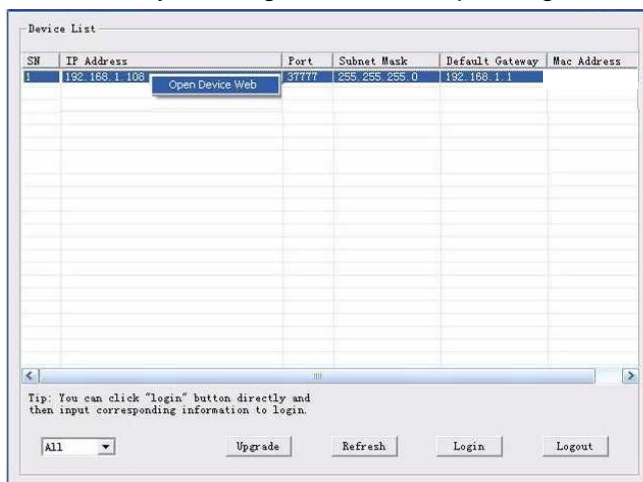

Figure 4-2 Search interface 2

If you want to modify the device IP address without logging in the device web interface, you can go to the configuration tool main interface to set.

In the configuration tool search interface (Figure 4-1), please select a device IP address and then double click it to open the login interface. Or you can select an IP address and then click the Login button to go to the login interface. See Figure 4-3.

In Figure 4-3, you can view device IP address, user name, password and port. Please modify the corresponding information to login.

Please note the port information here shall be identical with the port value you set in TCP port in Web Network interface. Otherwise, you cannot login the device.

If you are using device background upgrade port 3800 to login, other setups are all invalid.

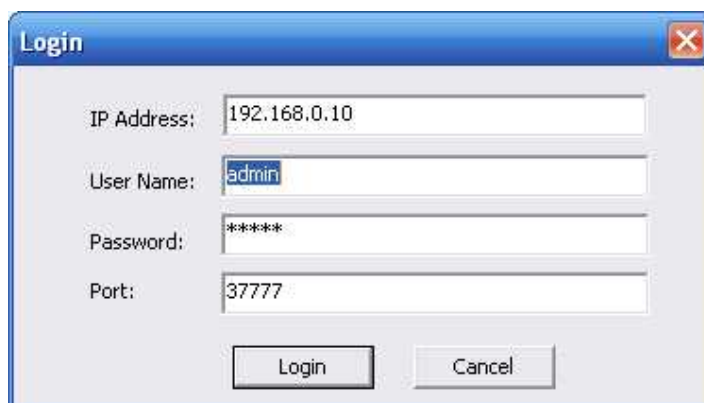

Figure 4-3 Login prompt

After you logged in, the configuration tool main interface is shown as below. See Figure 4-4.

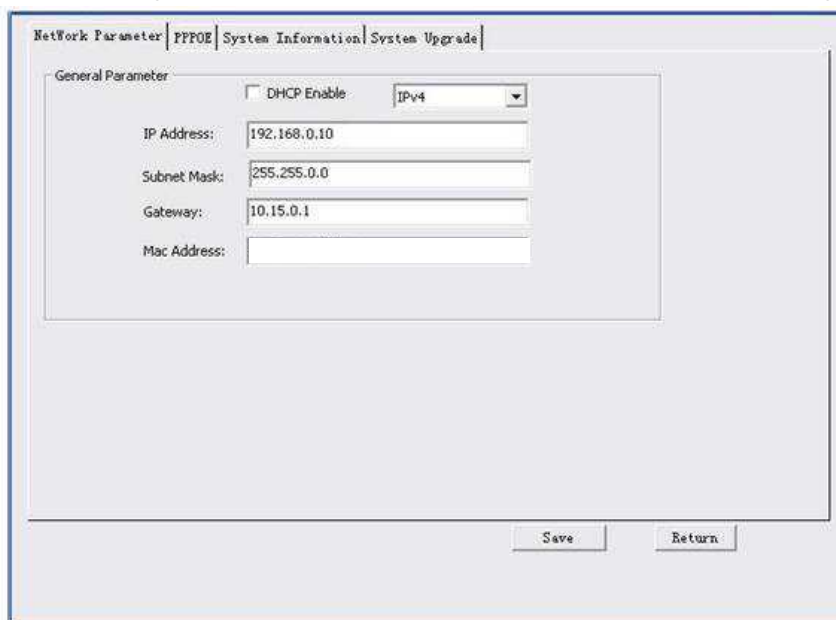

Figure 4-4 Main interface

**For detailed information and operation instruction of the quick configuration tool, please refer to the *Quick Configuration Tool User's Manual* included in the resources CD.**

## 5 Web Operation

This series network camera products support the Web access and management via PC. Web includes several modules: Monitor channel preview, system configuration, alarm and etc.

### 5.1 Network Connection

Please follow the steps listed below for network connection.

- Make sure the network camera has connected to the network properly.
- Please set the IP address, subnet mask and gateway of the PC and the network camera respectively. Network camera default IP address is 192.168.0.10. Subnet mask is 255.255.255.0. Gateway is 192.168.0.1
- Use order ping `***.***.***.***`(\* network camera address) to check connection is OK or not.

### 5.2 Login and Main Interface

Open IE and input network camera address in the address bar. See Figure 5- 1.

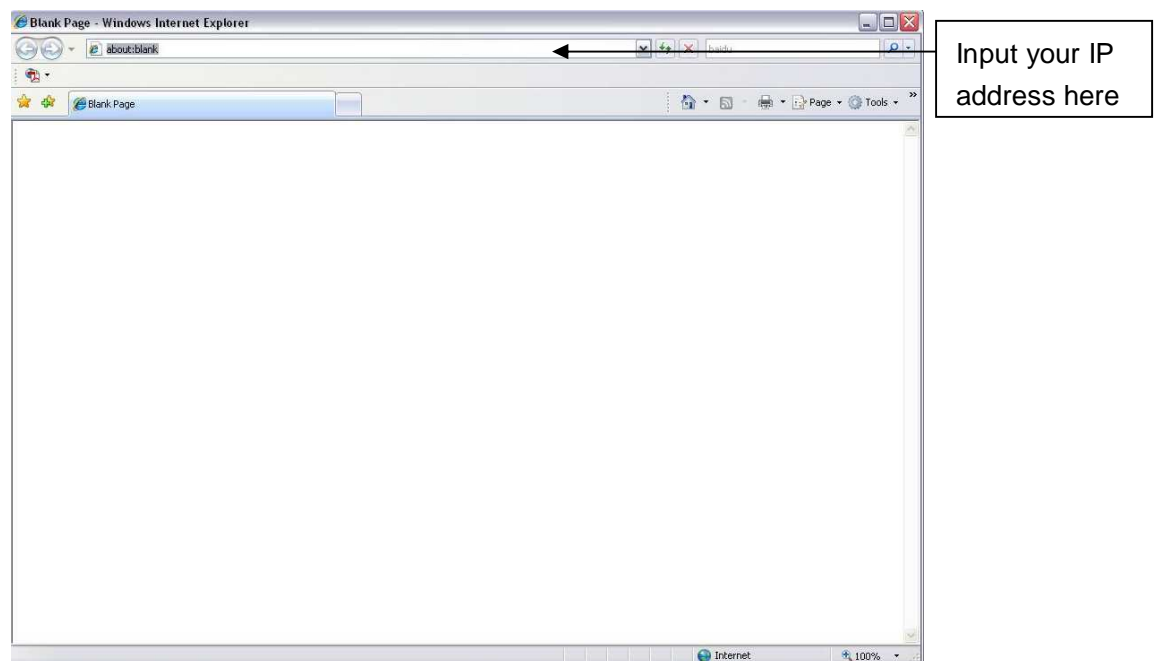

Figure 5- 1 IP address

The login interface is shown as below. See Figure 5- 2.

Please input your user name and password.

Default ID is admin and PWD is 12345.

**Note: For security reasons, please modify your password after you first login.**

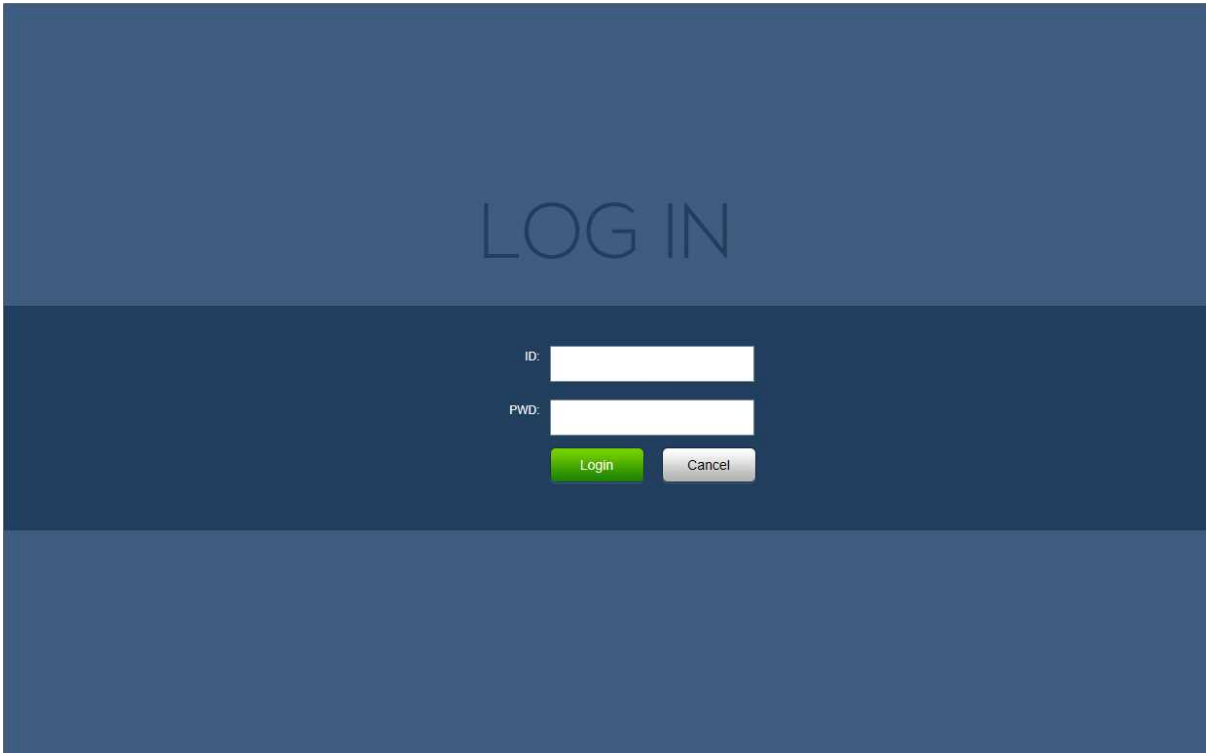

Figure 5- 2 Web login

If it is your first time to log in, system pops up warning information to ask you whether install web plug-in or not after you logged in for one minute. For detailed plug-in installation, please refer to the Web Operation Manual included in the resource CD.

After you logged in, you can see the main window.

Please refer to the Web Operation Manual included in the resource CD for detailed operation instruction.



## 6 FAQ

Bug	
I can not boot up the device or operate properly.	Please click RESET button for at least five seconds to restore factory default setup.
The water leakage occurred.	<p>The unauthorized front or rear cap remove many result in water leakage.</p> <p>The glass front cap has sustained heavy push or strike.</p> <p>The waterproof plug of the rear cap becomes loosen.</p>
IR video is poor.	<p>Do not use the proper supplying power. The IR light can not turn on completely.</p> <p>The object is out of the IR distance range of current device.</p> <p>IR-CUT does not turn to the night mode. The photosensitive chip of the front-end can not sense the IR light.</p>
I can not upgrade the device via network.	When network upgrade operation failed, you can use port 3800 to continue upgrade.
I can not login the client-end or the WEB.	<p>The ActiveX control is blocked.</p> <p>The display card version shall be dx8.1 or higher.</p> <p>Network connection error occurred.</p> <p>Invalid network setup.</p> <p>Invalid ID or PWD.</p>
I can not play the download file.	<p>There is no player.</p> <p>There is no DX8.1 or higher.</p> <p>For the MEDIA PLAYER, there shall be Div X503Bundle.exe plugin if you play the .AVI file.</p> <p>For Windows XP user, you need to install the plugin DivX503Bundle.exe and ffdsho-2004 1012.exe.</p>
To guarantee setup update	After you modified the important setup, please reboot the device via the software to make sure the setup has been updated to the storage medium.
Power adapter	<p>The general power adapter can work ranging from 0 to 40 . The device may result in unstable power supply when the temperature exceeds the working temperature.</p> <p>Please replace an industry-level power adapter if you are using in the harsh environments.</p>

**Note**

- **This user's manual is for reference only. Slight difference may be found in user interface.**
- **All the designs and software here are subject to change without prior written notice.**
- **All trademarks and registered trademarks mentioned are the properties of their respective owners.**
- **If there is any uncertainty or controversy, please refer to the final explanation of us.**