

# LIFEBREATH<sup>®</sup>

## AIR HANDLER

# OPERATION, SIZING AND INSTALLATION MANUAL

NOW WITH  
**FIVE YEAR WARRANTY**  
ON PARTS AND ACCESSORIES

### For Models:

AH40DHW  
AH60DHW  
AH40BHW  
AH60BHW  
AH80BHW



TO BE COMPLETED BY CONTRACTOR AFTER INSTALLATION

\_\_\_\_\_

Installing Contractor

\_\_\_\_\_

Telephone / Contact

\_\_\_\_\_

Serial Number

\_\_\_\_\_

Installation Date

\_\_\_\_\_

Model



**\* LEAVE FOR HOMEOWNER**

NOTE: Due to ongoing research and product development, specifications, ratings and dimensions are subject to change without notice.



# Table of Contents

|   |         |
|---|---------|
| <i>Introduction</i> .....                 | 3       |
| <i>Description and Purpose</i> .....      | 4       |
| <i>Combo System Basic Principle</i> ..... | 5       |
| <i>Specifications</i> .....               | 12 - 16 |
| <i>Installation</i> .....                 | 17      |
| <i>Plumbing</i> .....                     | 18      |
| <i>Electrical</i> .....                   | 19      |
| <i>Optional Dehumidistat</i> .....        | 20      |
| <i>Start Up Procedure</i> .....           | 21      |
| <i>Operation</i> .....                    | 22      |
| <i>Troubleshooting</i> .....              | 23      |
| <i>System Commissioning</i> .....         | 24      |
| <i>Work Sheets</i> .....                  | 25 - 30 |

# Introduction

Congratulations on your selection of the LIFE BREATH Air Handler. This is a very advanced unit that combines the outstanding efficiency and economy of the water heater/airhandler concept.

***With the addition of LIFE BREATH Turbulent Flow Precipitator (TFP) Air Cleaner (optional) you will have the ultimate in comfort and healthy indoor air quality.***

You will notice that the heated air in your home feels more comfortable than air heated by a conventional furnace. One reason for this is that LIFE BREATH's hydronically heated air is uniform and temperate... no short blasts of hot air or hot and cold temperature spikes. In this regard, the air flowing from your hot air vents will not feel as hot to the touch as air from a conventional furnace.

With a high efficiency, adequately sized hot water heater/boiler, you will always have plenty of hot water for showers and baths, washing dishes and clothes, and all other normal domestic hot water needs. If there is an unusually high demand for hot water, such as filling a large hot tub, than all you need to do is allow more time for the task so the water heater/boiler can keep up to its job of providing hot water for the heating system as well as other household uses.

Once it is correctly installed, safety will never be an issue with your LIFE BREATH Air Handler. No flames, fumes or flue gases to be concerned about. Your domestic hot water heater/boiler now provides the heat source for your air handler.

This Operating and Installation Guide will help you learn about your LIFE BREATH Air Handler quickly and easily. The table of contents will show you where to find information on every feature of this unit along with easy to understand operating instructions. If, however, you do encounter a question that is not covered in this Guide you should call the LIFE BREATH dealer who installed your air handler. Chances are that he will be able to give you a satisfactory answer but if he is unable to do so then we invite you to contact us directly.

*Nutech Brands Inc.*

# Description and Purpose

## IMPORTANT NOTE

The purpose of this manual is to act as an installation guide only for the LIFE BREATH Air Handler. Manufacturers' instructions for other components, such as the water heater/boiler, must be followed.

All national and local code requirements must be met when installing a LIFE BREATH Air Handler. Be sure to consult the proper authorities.

*Note: Temperatures greater than 130 °F (54°C) pose a serious risk of scalding individuals running domestic hot water for potable use.*

This appliance complies with IAS Canada Inc. Requirement CR95-003, Additional Requirements for Fan Coil Units for use with Potable Water Heaters.

All piping and components connected to this appliance shall be suitable for use with potable water.

Toxic chemicals, such as used for boiler treatment, shall not be introduced into the potable water heater system.

When using this system, and water for space heating, is required to be at a higher temperature than for other uses, an anti-scald valve shall be used to ensure water for other uses is reduced in temperature to minimize a scald hazard potential.

Combining two or more end uses such as space heating and the heating of domestic hot water in a

single system has the potential to increase efficiency and reduce overall capital costs. However, the proper design, installation, and commissioning of these systems is critical if these advantages are to be realized.

This manual provides a guideline of good engineering practice in the design, installation and commissioning of Integrated Combo Systems. The guidelines in the manual are designed for residential forced warm air Integrated Combo Systems which utilize domestic water heaters or boilers and the LIFE BREATH furnace. Heating and cooling loads shall be calculated in accordance with recognized Residential Heat Loss and Heat

Gain Calculation methods. Duct design shall comply with recognized Residential Air System Design methods. This manual provides worksheets to be used for the purpose of sizing residential water heaters and the combo furnace.

# Combo System Basic Principles

## Closed/Open Combo System

From the aspect of delivery of domestic hot water and space heating, the Open and Closed systems operate the same. A system becomes closed when a backflow prevention valve or check valve is installed in the cold water piping upstream of the water heater. A backflow prevention valve will prevent the pressure created when water is heated in the water heater, from being relieved into the cold water system.

Therefore, an expansion tank (or equivalent device) may be installed as part of any closed system. The operations of the valve and expansion tank are discussed later in this section of this manual.

*Note: Water systems that incorporate a pressure tank (well systems) are normally open systems.*

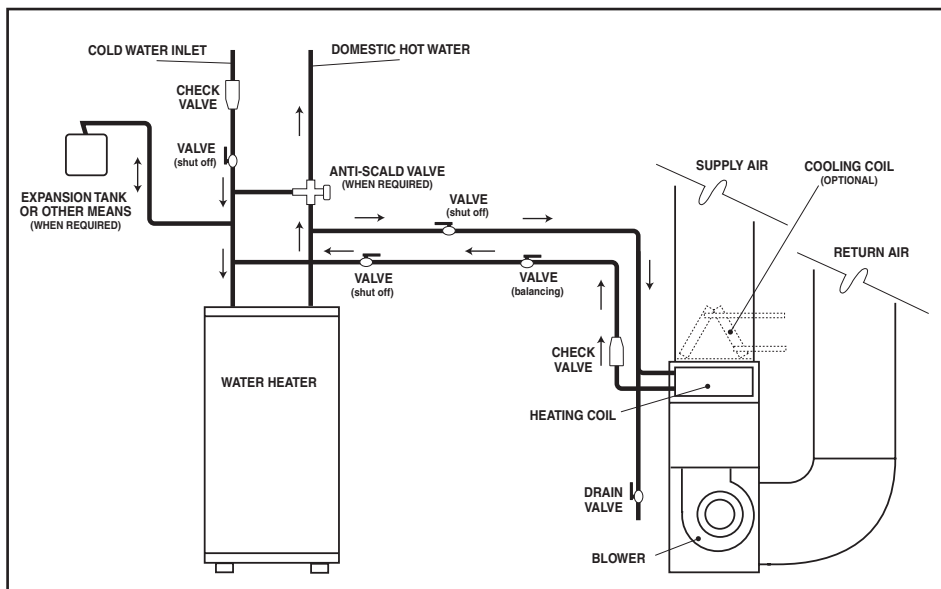

**SCHEMATIC SYSTEM DIAGRAM (Closed Loop System)**

**SCHEMATIC SYSTEM DIAGRAM (Open System)**

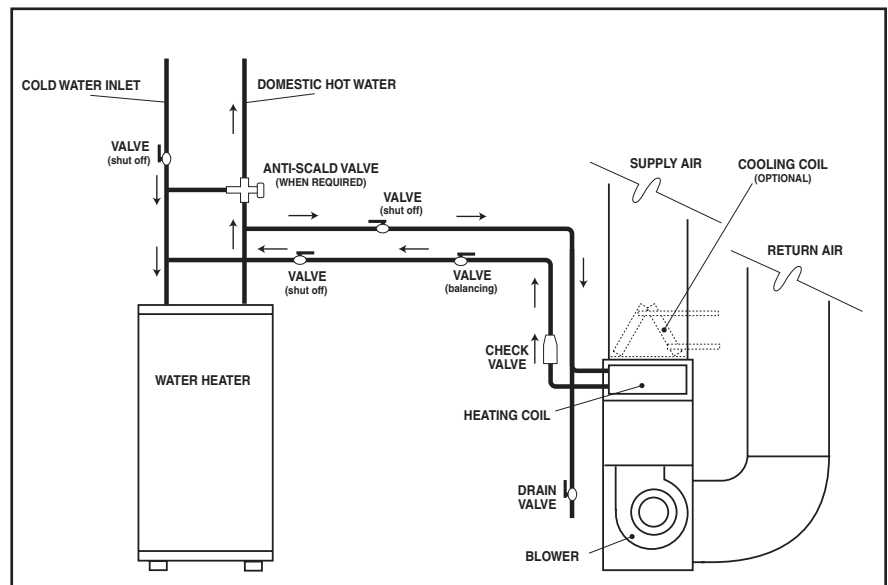

*Note: Plumbing components and system configuration may vary from diagram portrayed. Refer to local codes, local bylaws and installation manuals supplied with water heater before starting any installation work.*

## Call for Space Heating Only Operation

When the thermostat calls for heat, the circulation pump is activated and hot water is drawn from the top of the water heater through the air handler, and then returned to the water heater. There should be at least a 20°F (11°C) temperature drop between the hot water supplied to the air handler and the returning water temperature. If the temperature drop is less than 20°F (11°C) two things may happen:

1. Mixing of warm return water with the hot water within the water heater (no tank stratification), which will result in a lower hot water supply temperature.
2. A water heater thermostat temperature differential (between on and off) is approximately 18°F (10°C). Therefore, if the return water is not cool enough, it may not activate the water heater thermostat, which causes the burner to operate. All of the water in the water heater will be cooled before the burner begins to operate. This may cause large swings in the delivered hot water temperature, causing poor space heating performance, fluctuating domestic water temperatures and effectively reducing the supply of domestic hot water.

## Call for Domestic Hot Water and Space Heating Operation

When both return water from the space heating loop and new cold water (replacing domestic water being used) enters the water heater, the mixed entering water is cool enough to activate the thermostat quickly. In this situation, the water heater must be capable of satisfying the combined need for hot water (domestic hot water and space heating) at the same time.

## Air System

A circulation fan draws cool house air at approx. 70°F (21°C) from the return ductwork, forces it through the water coil where it is heated, and then distributes it to the various rooms of the house through the supply ductwork.

## Water Piping

The Piping and fittings used to connect the water heater and air handler must be sized to handle the volume of hot water required by the air handler within the pressure limitations of the circulation pump. All piping, fittings solders, and fluxes must be acceptable for use with domestic hot water.

*Note: Chemicals (such as boiler system additives) cannot be added to the system because water passing through the heating loop re-enters the domestic water systems.*

## Circulation Pump

The circulation pump is factory installed within the air handler. The water flow rate will vary depending on the pumps performance and the head pressure (resistance) of the complete heating loop system.

## Manual Valves

There are a number of manual valves required for the system to operate properly and safely. These valves are used as shut off valves, drain valves and throttling valves. They can be globe, gate, ball or balancing type valves.

The **globe valve** can be used as a shut off, drain or throttling valve. Even in the open position, the valve is fairly restrictive to flow. It has a much greater equivalent length (resistance) than the other types of valves.

The **gate valve** can be used as a shut off or drain valve. When in the open position, there is very little resistance to flow. Gate valves have a greater susceptibility to chatter (noise) and

malfunction with age. Gate valves tend to be less expensive than the other type of valves.

The **ball valve** can be used as a shut off or drain valve but not a throttling (balancing) valve. When in the open position, a full bore ball valve has very little resistance to flow, and these valves tend to be both the least expensive and the least susceptible to seizing over time. Do not use reduced bore ball valves as they are very restrictive to water flow.

The **balancing valve** can be used as a throttling valve. It can make small flow changes easily and has lower resistance than a globe valve. This valve will be considerable more expensive.

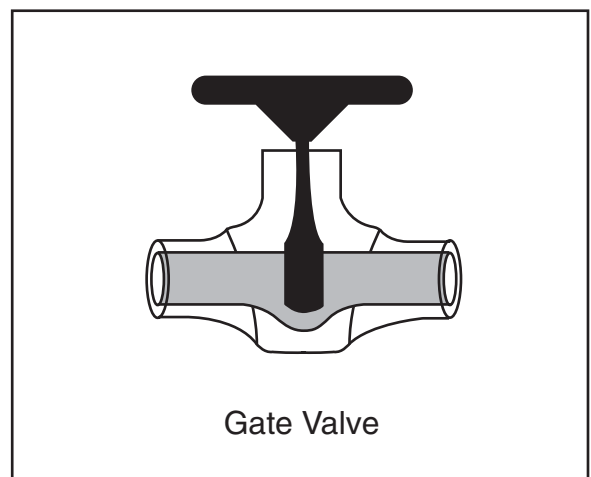
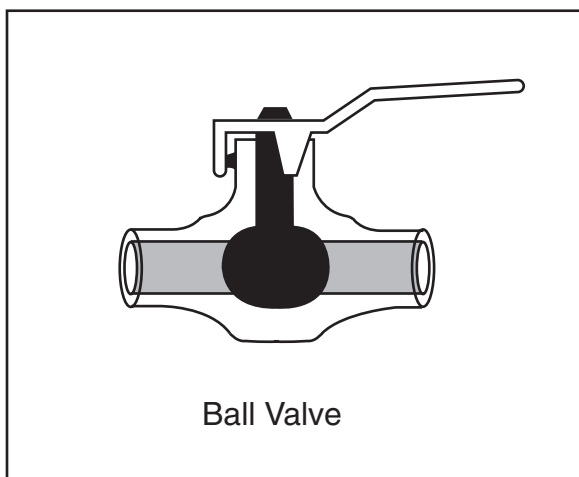
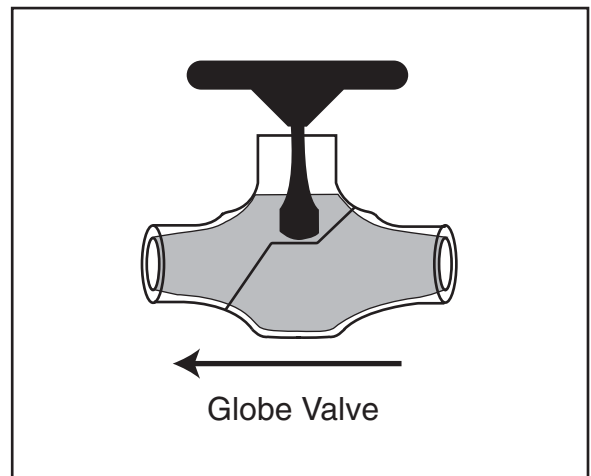
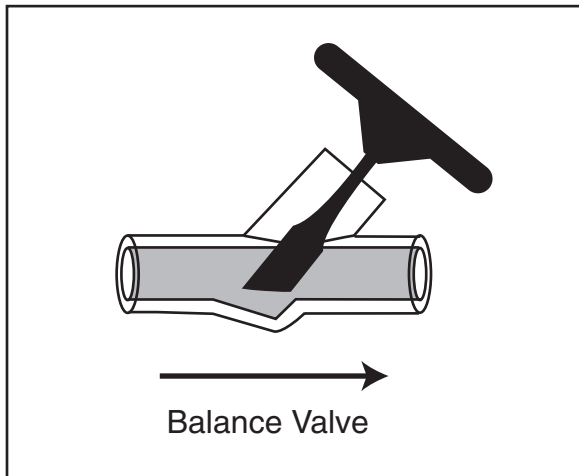

## Shut Off Valves

There are 3 shut off valves required for an integrated combo system as follows:

- One valve (a) on the cold water side of the water heater upstream of the heating loop connection. This valve has the ability to isolate the hot water (domestic and space heating) from the household cold water supply. This valve is required on every water heater whether or not the water heater is used for space heating.
- One valve (b) on the hot water supply side of the heating loop, downstream of its connection to the domestic water.
- One valve (c) on the return side of the heating loop upstream of its connection to the domestic cold water.

The two valves in the heating loop allow the heating loop to be isolated for service or repair.

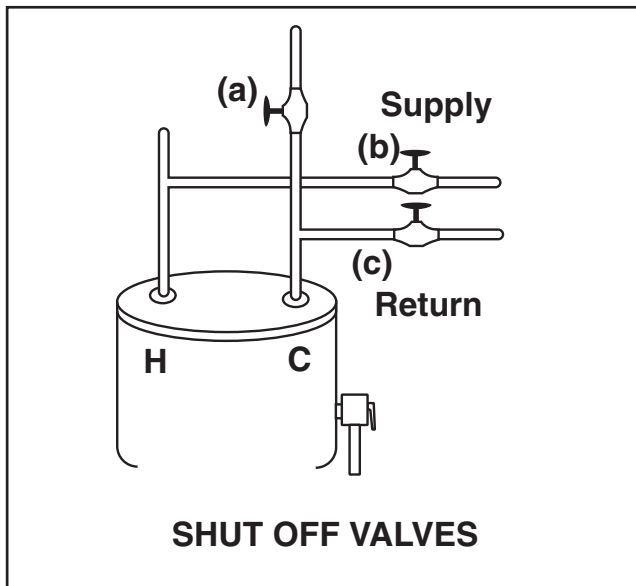

## Drain Valve

A drain valve is required to allow the heating loop to be drained for service or repair and to remove air from the heating loop when commissioning a

system. The drain valve should be near the low point of the return piping system upstream of the shut off valve and is preferred to be near the water heater.

## Throttling Valve

The throttling (balancing) valve is used to reduce the water flow rate and thereby increase the water temperature drop. This is done to ensure proper activation of the water heater thermostat. This valve should be a globe or balancing valve.

## Check Valves

A spring loaded check valve is required in the heating loop to help minimize thermo-siphoning of hot water throughout the heating loop when heating is not called for and cold water back flowing through the heating loop when domestic hot water is used. The valve will have a water flow direction arrow marked on its exterior surface and must be installed with that arrow pointing downstream.

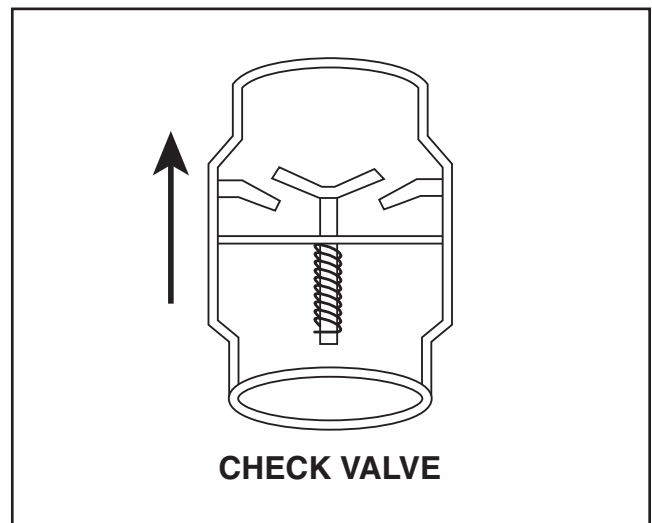

*\* Check valves should always be installed in a vertical rise with the flow of water shown.*



## Expansion Tanks

Expansion tanks are only required for “Closed Systems”. The expansion tank has an air bladder, which will contract to relieve pressure in the system. Pressure is created in the closed system when water is heated in the water heater. Expansion tanks should always be connected to the cold water piping between the water heater shut off valve and the cold water inlet to the water heater. Follow manufacturers instructions for sizing and installation.

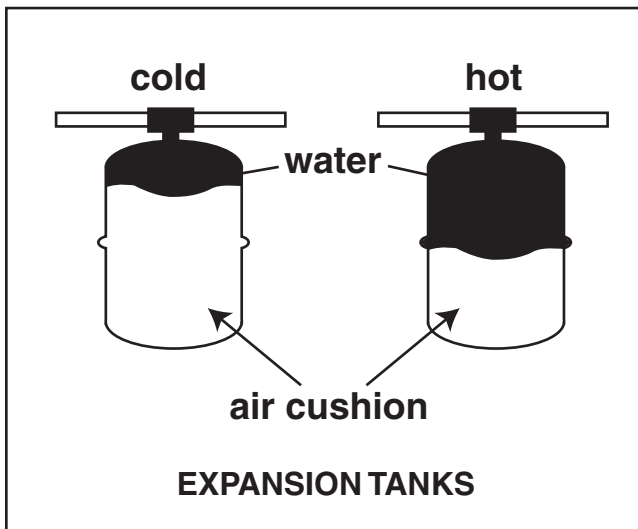

## Anti-Scald Valve

An anti-scald valve is required when the water heater thermostat is set above 140°F (60°C). Also, an anti-scald valve may be required for all installations by the “authority having jurisdiction”. The valve is placed in the hot water supply piping from the water heater downstream of the heating loop connection and upstream of any domestic hot water connection.

The purpose of the valve is to limit the maximum temperature available for domestic hot water by mixing hot water from the water heater with cold water from the municipal supply.

The Anti-Scald valve must be thermostatically controlled and approved to the ASSE standard No. 1016 and 1017 for use as an anti-scald device.

*Note: There are a number of pressure balancing valves and mixing valves on the market which are not certified as a anti-scalding device.*

| <b>Time to Scald</b><br>(1st degree burns) |             |
|--|-------------|
| <b>Temperature</b>                         | <b>Time</b> |
| 120°F                                      | 8 min.      |
| 130°F                                      | 20 sec.     |
| 140°F                                      | 3 sec.      |
| 160°F                                      | <1 sec.     |

## Off Season Circulation Controls

(Models with a ‘T’ in the model number)

Although the UCG (Unified Canadian Guideline) does not require these controls, a few building codes and municipal by-laws do. They are used to provide periodic circulation of water through the space heating loop during the summer and other periods of infrequent use. The concern is that water which remains stationary in the heating loop during the summer may be less than desirable as domestic hot water when it is returned to the water heater at system startup in the fall.

## Thermostats

There are two thermostats controlling every combo system, the water heater thermostat controlling the hot water temperature and the room thermostat controlling the room air temperature.

## Water Heater Thermostat

The water heater thermostat is set by the installing contractor to provide the required temperature at the hot water outlet of the water heater. It is important that a warning label be placed near the water heater thermostat telling the homeowner not to change the thermostat setting. The label is included with the furnace.

## Room Thermostat

The room thermostat controls both the water circulation pump and the air circulation fan. It should be on a centrally located, inside wall away from any source of heat such as diffusers, appliances and direct sunlight.

## Energy Saving Room Thermostat

A set back thermostat or “smart stat” can be used with a combo system, but care must be taken in the timing of the temperature changes. The timing of morning warm up should be early enough that the desired air temperature has been reached before the people begin to use domestic hot water. The highest demand for space heating is during the morning warm up and the highest demand for domestic hot water is during morning showers. Even if the water heater is properly sized, it may not be able to meet this combined load. Therefore, large set backs should be avoided.

## Air Handler Output Capacity

There are four factors that will significantly affect the heating output of the air handler.

They are:

- Hot water supply temperature (EWT)
- Hot water flow rate (GPM)
- Air Handler return air temperature
- Air Handler air flow rate (CFM)

The hot water inlet temperature is typically 140°F (60°C). If this temperature must be increased

to achieve higher outputs from the furnace an anti-scald valve must be used to prevent domestic hot water temperatures above 140°F (60°C). The manufacturer of the Hot Water Tank should be consulted for temperatures higher than 140°F.

## Hot Water Flow Rate

The hot water entering the water coil is the source of heat to the air handler. The effect of changing the amount of water entering the coil is the same as changing the water temperature. As water flow is reduced, the output of the air handler and the air temperature rise will both be lowered.

## Air Handler Return Air Temperature

The return air temperature entering the air handler is approx. 60°F (33°C) below the hot water inlet temperature. If the return air temperature entering the air handler is reduced, more heat transfer will occur and the output of the air handler will increase.

## Air Handler Air Flow Rate

The air entering the air handler can only be warmed by the temperature difference between the hot water and the cool air. As the volume (CFM (L/s)) of air is reduced, the amount of heat which can be transferred is also reduced.

## Air Handler Temperature Rise

In a fuel fired furnace, the combustion gases can be 1000°F (538°C) above the return air temperature. These units typically have a temperature rise from 50°F (10°C) to 90°F (32°C) and therefore delivers air at the diffuser at 120°F (49°C) to 160°F (71°C).

With an Integrated Combo System, the hot water temperature is approx. 130°F (54°C) which is 60°F (15.5°C) above the return air temperature. These units typically have a temperature rise of 35°F (2°C) to 40°F (4°C) and therefore would deliver air at the diffuser at approximately 105°F (40.5°C) to 110°F (43°C).

## Design vs. Field Conditions

The factors discussed above become very important to consumer comfort. Even small differences between design parameters and actual field conditions can impact greatly on output capacity. Therefore, it is important to do a thorough and complete commissioning of the integrated combo system to ensure the design parameters are met.

## Water System Pressures

Within the water system of an Integrated Combo system, there are three terms that the designer/installer must understand. These are head pressure, water flow rate, and pressure drop.

### Head Pressure

Head pressure is the pressure created by the circulation pump to push water through the piping system. It is this pressure which is used to overcome the resistance to water flow (friction) caused by the water pipe and fittings. It is similar in concept to the external static pressure in an air duct system. Head pressure is measured in feet or water (millimeters of water).

*Note: Although the water in the combo system is pressurized by the domestic water system the pump is required to create water flow in the heating loop. The domestic water system applies the same pressure to the supply and return sides of heating loop.*

*Note: The vertical height of the heating loop does not impact on the head pressure as the pressure required to push the water up the vertical height is offset by the weight of the water in the vertical drop on the other side of the heating loop.*

### Flow Rate

Flow rate is the amount of water flowing in the system. It is directly related to the head pressure and the resistance to flow. Flow rate is measured in gallons per minute (liters per minute).

### Pressure Drop (PD)

Pressure drop (PD) is the reduction in total pressure caused by components added to a piping system such as coils, valves, and fittings. The measurement of pressure drop is the difference in pressure on the inlet side of the component and the outlet side. Pressure drop is measured in feet of water (millimeters of water).

When connecting the water lines for heating loop (air handler) to the domestic water system, the pipes should be connected with a “tee” to the side of a vertical domestic water pipe or the bottom of a horizontal domestic water pipe. This is to help prevent air from entering the heating loop. The connections should be as near as practical to the water heater.

# Specifications

# Model AH40DHW

**Filters** 1" pleated in return plenum side.

**Case** Prepainted galvanized steel for superior corrosion resistance.

### AH40DHW OUTPUT (MBH)

| CFM @ .5" WG  | AH40DHW OUTPUT (MBH) |      |      |      |      |      |      |      |      |       |       |       |       |       |       |       |       |       |
|---------------|----------------------|------|------|------|------|------|------|------|------|-------|-------|-------|-------|-------|-------|-------|-------|-------|
|               | 40.7                 | 47.7 | 54.8 | 61.9 | 69.0 | 76.2 | 83.3 | 90.4 | 97.5 | 104.6 | 111.7 | 118.8 | 125.9 | 133.0 | 140.1 | 147.2 | 154.3 | 161.4 |
| 890           | 40.7                 | 47.7 | 54.8 | 61.9 | 69.0 | 76.2 | 83.3 | 90.4 | 97.5 | 104.6 | 111.7 | 118.8 | 125.9 | 133.0 | 140.1 | 147.2 | 154.3 | 161.4 |
| 790           | 38.0                 | 44.5 | 51.0 | 57.6 | 64.3 | 70.9 | 77.5 | 84.1 | 90.7 | 97.3  | 103.9 | 110.5 | 117.1 | 123.7 | 130.3 | 136.9 | 143.5 | 150.1 |
| 740           | 36.5                 | 42.7 | 49.0 | 55.3 | 61.7 | 68.0 | 74.3 | 80.6 | 86.9 | 93.2  | 99.5  | 105.8 | 112.1 | 118.4 | 124.7 | 131.0 | 137.3 | 143.6 |
| 660           | 33.8                 | 39.6 | 45.5 | 51.3 | 57.2 | 63.0 | 68.8 | 74.6 | 80.4 | 86.2  | 92.0  | 97.8  | 103.6 | 109.4 | 115.2 | 121.0 | 126.8 | 132.6 |
| CFM @ .25" WG | 1030                 | 44.0 | 51.7 | 59.3 | 67.0 | 74.8 | 82.5 | 90.2 | 97.9 | 105.6 | 113.3 | 121.0 | 128.7 | 136.4 | 144.1 | 151.8 | 159.5 | 167.2 |
|               | 900                  | 41.0 | 48.0 | 55.1 | 62.3 | 69.4 | 76.6 | 83.7 | 90.8 | 97.9  | 105.0 | 112.1 | 119.2 | 126.3 | 133.4 | 140.5 | 147.6 | 154.7 |
|               | 825                  | 38.9 | 46.7 | 52.4 | 59.2 | 66.0 | 72.8 | 79.6 | 86.4 | 93.2  | 100.0 | 106.8 | 113.6 | 120.4 | 127.2 | 134.0 | 140.8 | 147.6 |
|               | 740                  | 36.5 | 42.7 | 49.0 | 55.3 | 61.7 | 68.0 | 74.3 | 80.6 | 86.9  | 93.2  | 99.5  | 105.8 | 112.1 | 118.4 | 124.7 | 131.0 | 137.3 |
| Water Temp.   | 130                  | 140  | 150  | 160  | 170  | 180  | 130  | 140  | 150  | 160   | 170   | 180   | 130   | 140   | 150   | 160   | 170   | 180   |

3 GPM
4 GPM
5 GPM

## Dimensions & Clearances

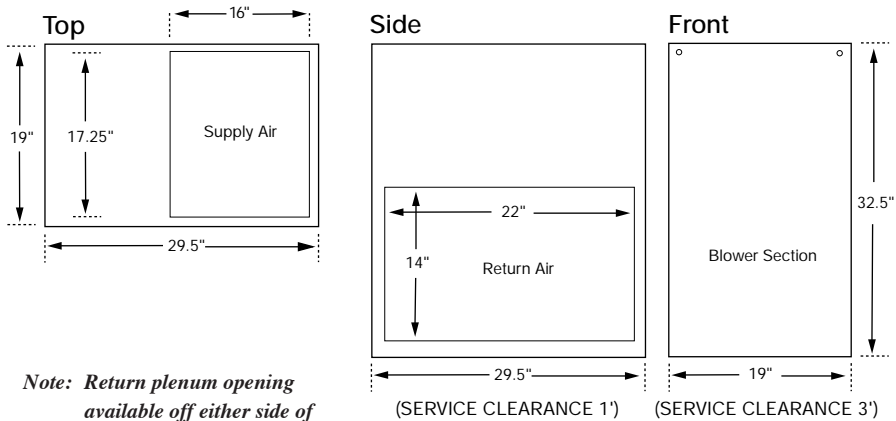

*Note: Return plenum opening available off either side of cabinet. All units conform to CSA and UL Standards*

| Model                                    | AH40DHW                         |
|--|---------------------------------|
| Voltage                                  | 120 VAC 60 Hz                   |
| Hp                                       | 1/3                             |
| Amps (total)                             | 7                               |
| Water Connections                        | 1/2" Copper Soldered Connection |
| Airflow (High)<br>.25 in wg<br>.5 in. wg | 1030 CFM<br>890 CFM             |
| Net Weight                               | 111 lbs.                        |
| Shipping Weight                          | 130 lbs.                        |

## Warranty

Units carry a five year replacement parts warranty on all components.

# Specifications

# Model AH60DHW

**Filters** 1" pleated in return plenum side.

**Case** Prepainted galvanized steel for superior corrosion resistance.

### AH60DHW OUTPUT (MBH)

| CFM @ 25" WG | CFM @ 5" WG |      |      |      |      |       |      |      |      |      |       |       |      |      |      |      |       |       |
|--------------|-------------|------|------|------|------|-------|------|------|------|------|-------|-------|------|------|------|------|-------|-------|
|              | 130         | 140  | 150  | 160  | 170  | 180   | 130  | 140  | 150  | 160  | 170   | 180   | 130  | 140  | 150  | 160  | 170   | 180   |
| 1180         | 51.4        | 60.2 | 69.0 | 77.9 | 86.8 | 95.8  | 56.3 | 65.9 | 75.6 | 85.3 | 95.0  | 104.8 | 59.4 | 69.5 | 79.7 | 89.9 | 100.1 | 110.3 |
| 1120         | 50.0        | 58.7 | 67.2 | 75.9 | 84.5 | 93.2  | 54.5 | 63.9 | 73.2 | 82.6 | 92.0  | 101.5 | 57.4 | 67.1 | 76.9 | 86.8 | 96.6  | 106.5 |
| 890          | 43.9        | 51.4 | 60.0 | 66.5 | 74.1 | 81.7  | 46.9 | 54.9 | 62.9 | 70.9 | 79.0  | 87.1  | 48.7 | 56.9 | 65.3 | 73.5 | 81.8  | 90.2  |
| 675          | 36.6        | 42.8 | 49.0 | 55.3 | 61.5 | 67.8  | 38.2 | 44.7 | 51.2 | 57.7 | 64.2  | 70.7  | 37.3 | 43.7 | 50.0 | 56.4 | 62.8  | 69.2  |
| 1350         | 54.7        | 64.2 | 73.6 | 83.1 | 92.6 | 102.1 | 60.8 | 71.2 | 81.7 | 92.2 | 102.7 | 113.3 | 64.7 | 75.8 | 86.8 | 98.0 | 109.2 | 120.4 |
| 1275         | 53.3        | 62.5 | 71.7 | 80.9 | 90.2 | 99.5  | 58.9 | 69.0 | 79.1 | 89.3 | 99.5  | 109.7 | 62.4 | 73.1 | 83.8 | 94.5 | 105.3 | 116.5 |
| 940          | 45.4        | 53.2 | 60.9 | 68.8 | 76.6 | 84.5  | 48.7 | 57.0 | 65.3 | 73.7 | 82.1  | 90.4  | 50.7 | 59.3 | 67.9 | 76.6 | 85.3  | 94.0  |
| 730          | 38.6        | 45.2 | 51.8 | 58.4 | 65.0 | 71.7  | 40.6 | 47.5 | 54.4 | 61.3 | 68.3  | 75.2  | 41.8 | 48.8 | 55.9 | 63.0 | 70.1  | 77.2  |
| Water Temp.  | 130         | 140  | 150  | 160  | 170  | 180   | 130  | 140  | 150  | 160  | 170   | 180   | 130  | 140  | 150  | 160  | 170   | 180   |

3 GPM
4 GPM
5 GPM

## Dimensions & Clearances

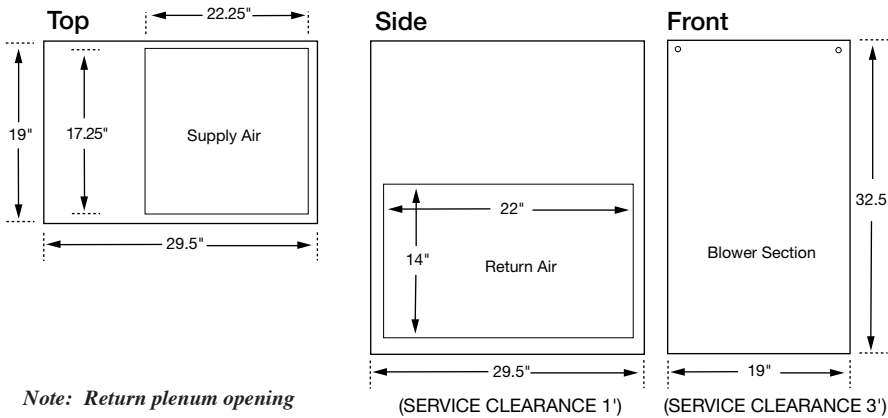

*Note: Return plenum opening available off either side of cabinet. All units conform to CSA and UL Standards*

| Model AH60DHW                            |                                 |
|--|---------------------------------|
| Voltage                                  | 120 VAC 60 Hz                   |
| Hp                                       | 1/2                             |
| Amps (total)                             | 8.7                             |
| Water Connections                        | 3/4" Copper Soldered Connection |
| Airflow (High)<br>.25 in wg<br>.5 in. wg | 1350 CFM<br>1180 CFM            |
| Net Weight                               | 121 lbs.                        |
| Shipping Weight                          | 140 lbs.                        |

## Warranty

Units carry a five year replacement parts warranty on all components.

# Specifications

# Model AH40BHW

**Filters** 1" pleated in return plenum side.

**Case** Prepainted galvanized steel for superior corrosion resistance.

**AH40BHW Output (MBH)**

| CFM @ .25" WG | Water Temp. |      |      |      |      |      |      |      |      |      |      |      |      |      |      |      |      |      |
|---------------|-------------|------|------|------|------|------|------|------|------|------|------|------|------|------|------|------|------|------|
|               | 130         | 140  | 150  | 160  | 170  | 180  | 130  | 140  | 150  | 160  | 170  | 180  | 130  | 140  | 150  | 160  | 170  | 180  |
| 1075          | 27.5        | 32.3 | 37.0 | 41.6 | 46.6 | 51.1 | 29.0 | 34.1 | 39.1 | 44.2 | 49.3 | 54.2 | 30.5 | 35.4 | 40.8 | 45.9 | 51.1 | 56.5 |
| 1040          | 27.3        | 31.9 | 36.4 | 41.0 | 45.8 | 50.4 | 28.7 | 33.6 | 38.4 | 43.4 | 48.5 | 53.3 | 29.8 | 35.0 | 40.1 | 45.1 | 50.2 | 55.2 |
| 975           | 26.3        | 30.8 | 35.3 | 39.8 | 44.1 | 48.8 | 27.7 | 32.8 | 37.3 | 42.0 | 46.9 | 51.6 | 28.8 | 33.8 | 38.4 | 43.5 | 48.3 | 53.3 |
| 880           | 25.0        | 29.2 | 33.5 | 38.0 | 42.2 | 46.5 | 26.4 | 31.0 | 35.4 | 39.9 | 44.5 | 49.1 | 27.4 | 32.0 | 36.6 | 41.3 | 45.9 | 50.5 |
| 1280          | 29.8        | 35.0 | 40.0 | 45.1 | 50.3 | 55.8 | 31.8 | 37.3 | 42.8 | 48.3 | 53.9 | 59.4 | 33.4 | 38.9 | 44.8 | 50.6 | 56.2 | 62.2 |
| 1200          | 28.9        | 33.9 | 38.8 | 43.8 | 48.9 | 53.9 | 30.9 | 36.1 | 41.4 | 46.8 | 52.1 | 57.4 | 32.2 | 37.7 | 43.2 | 48.7 | 54.2 | 59.8 |
| 1000          | 26.5        | 31.1 | 35.6 | 40.2 | 44.8 | 49.4 | 28.2 | 33.0 | 37.8 | 42.6 | 47.4 | 52.3 | 29.2 | 34.2 | 39.2 | 44.2 | 49.2 | 54.2 |
| 1020          | 26.8        | 31.4 | 36.2 | 40.7 | 45.3 | 50.0 | 28.3 | 33.1 | 37.9 | 42.9 | 47.8 | 52.8 | 29.4 | 34.6 | 39.6 | 44.7 | 49.8 | 54.9 |

3 GPM
4 GPM
5 GPM

## Dimensions & Clearances

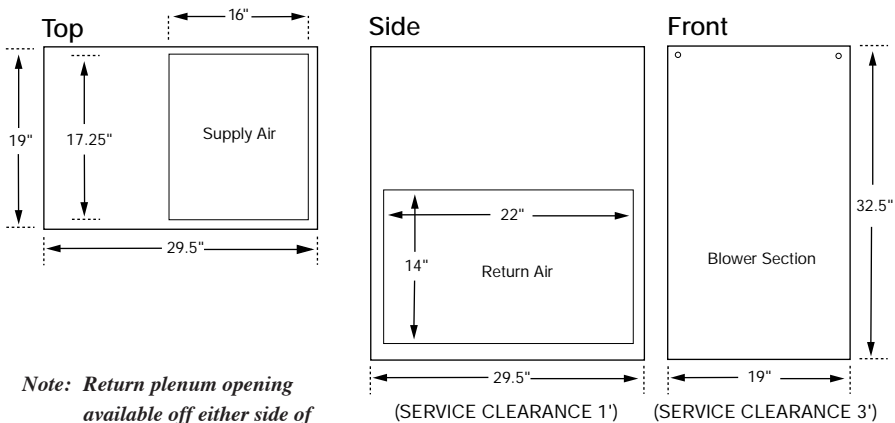

*Note: Return plenum opening available off either side of cabinet. All units conform to CSA and UL Standards*

| Model             | AH40BHW                            |
|-------------------|------------------------------------|
| Voltage           | 120 VAC 60 Hz                      |
| Hp                | 1/3                                |
| Amps (total)      | 7                                  |
| Water Connections | 1/2" Copper Soldered Connection    |
| Airflow (High)    | 1280 CFM<br>.25 in. wg<br>1075 CFM |
| Net Weight        | 111 lbs.                           |
| Shipping Weight   | 130 lbs.                           |

## Warranty

Units carry a five year replacement parts warranty on all components.

# Specifications

# Model AH60BHW

**Filters** 1" pleated in return plenum side.

**Case** Prepainted galvanized steel for superior corrosion resistance.

**AH60BHW Output (MBH)**

| CFM @ .5" WG  | AH60BHW Output (MBH) |      |      |      |      |      |      |      |             |      |      |      |      |      |      |      |      |      |      |     |     |
|---------------|----------------------|------|------|------|------|------|------|------|-------------|------|------|------|------|------|------|------|------|------|------|-----|-----|
|               | 1220                 | 1175 | 1022 | 705  | 1402 | 1357 | 1090 | 731  | Water Temp. | 130  | 140  | 150  | 160  | 170  | 180  | 130  | 140  | 150  | 160  | 170 | 180 |
|               | 32.9                 | 38.5 | 44.2 | 49.8 | 55.4 | 61.1 | 35.2 | 41.2 | 47.2        | 53.2 | 59.2 | 65.3 | 36.7 | 43.0 | 49.2 | 55.4 | 61.7 | 68.0 |      |     |     |
|               | 32.8                 | 37.8 | 43.3 | 48.9 | 54.4 | 60.0 | 34.5 | 40.4 | 46.2        | 52.1 | 58.0 | 63.9 | 36.0 | 42.0 | 48.1 | 54.3 | 60.4 | 66.5 |      |     |     |
|               | 30.2                 | 35.3 | 40.4 | 45.6 | 50.8 | 55.9 | 32.0 | 37.5 | 42.9        | 48.4 | 53.8 | 59.3 | 33.3 | 38.9 | 44.5 | 50.2 | 55.8 | 61.5 |      |     |     |
|               | 24.7                 | 28.9 | 33.1 | 37.3 | 41.5 | 45.7 | 25.9 | 30.2 | 34.6        | 39.0 | 43.4 | 47.8 | 26.6 | 31.1 | 35.6 | 40.1 | 44.6 | 49.1 |      |     |     |
| CFM @ .25" WG | 1402                 | 35.1 | 41.0 | 47.0 | 53.1 | 59.1 | 65.1 | 37.7 | 44.1        | 50.6 | 57.0 | 63.5 | 70.0 | 39.5 | 46.2 | 52.9 | 59.7 | 66.4 | 73.2 |     |     |
|               | 1357                 | 34.6 | 40.4 | 46.4 | 52.3 | 58.2 | 64.2 | 37.1 | 43.4        | 49.8 | 56.1 | 62.5 | 68.9 | 38.8 | 45.4 | 52.0 | 58.7 | 65.3 | 71.9 |     |     |
|               | 1090                 | 31.2 | 36.5 | 41.8 | 47.1 | 52.4 | 57.8 | 33.2 | 38.8        | 44.4 | 50.1 | 55.8 | 61.4 | 34.5 | 40.3 | 46.2 | 52.0 | 57.9 | 63.8 |     |     |
|               | 731                  | 25.5 | 29.5 | 33.8 | 38.1 | 42.4 | 46.7 | 26.4 | 30.9        | 35.4 | 39.9 | 44.4 | 48.9 | 27.2 | 31.8 | 36.4 | 41.0 | 45.6 | 50.2 |     |     |
|               |                      |      |      |      |      |      |      |      |             |      |      |      |      |      |      |      |      |      |      |     |     |
|               |                      |      |      |      |      |      |      |      |             |      |      |      |      |      |      |      |      |      |      |     |     |
|               |                      |      |      |      |      |      |      |      |             |      |      |      |      |      |      |      |      |      |      |     |     |

3 GPM
4 GPM
5 GPM

## Dimensions & Clearances

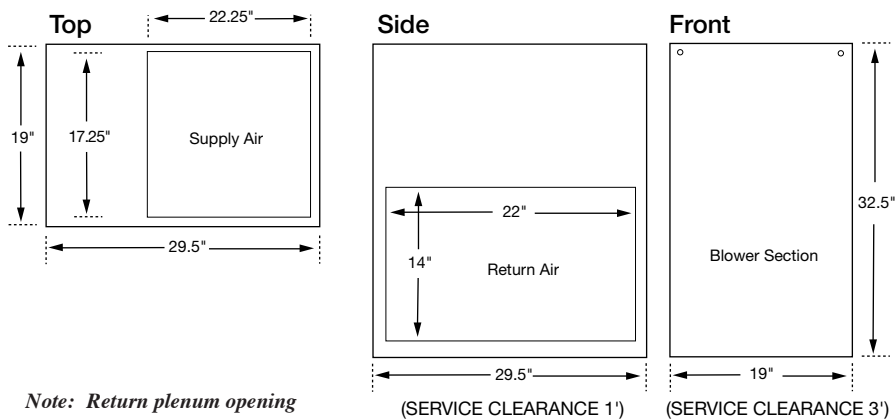

*Note: Return plenum opening available off either side of cabinet. All units conform to CSA and UL Standards*

| Model AH60BHW     |                                 |
|-------------------|---------------------------------|
| Voltage           | 120 VAC 60 Hz                   |
| Hp                | 1/2                             |
| Amps (total)      | 8.7                             |
| Water Connections | 1/2" Copper Soldered Connection |
| Airflow (High)    | .25 in wg<br>.5 in. wg          |
|                   | 1402 CFM<br>1220 CFM            |
| Net Weight        | 121 lbs.                        |
| Shipping Weight   | 140 lbs.                        |

## Warranty

Units carry a five year replacement parts warranty on all components.

# Specifications

# Model AH80BHW

**Filters** 1" pleated in return plenum side.

**Case** Prepainted galvanized steel for superior corrosion resistance.

|               |      | AH80BHW Output (MBH) |      |      |      |      |      |       |      |      |      |      |      |       |      |      |      |      |      |
|---------------|------|----------------------|------|------|------|------|------|-------|------|------|------|------|------|-------|------|------|------|------|------|
| CFM @ .5" WG  | 1639 | 37.5                 | 43.9 | 50.3 | 56.8 | 63.3 | 69.7 | 40.7  | 47.6 | 54.5 | 61.5 | 68.5 | 75.5 | 42.8  | 50.0 | 57.3 | 64.6 | 71.9 | 79.3 |
|               | 1618 | 37.3                 | 43.7 | 50.0 | 56.5 | 62.9 | 69.3 | 40.4  | 47.2 | 54.2 | 61.1 | 68.0 | 75.0 | 42.5  | 49.7 | 56.9 | 64.2 | 71.5 | 78.7 |
|               | 1575 | 36.9                 | 43.2 | 49.5 | 55.8 | 62.2 | 68.6 | 39.9  | 46.7 | 53.5 | 60.3 | 67.2 | 74.0 | 41.9  | 49.0 | 56.1 | 63.3 | 70.5 | 77.7 |
| CFM @ .25" WG | 1967 | 40.4                 | 47.3 | 54.2 | 61.1 | 68.1 | 75.1 | 44.1  | 51.6 | 59.2 | 66.7 | 74.3 | 81.9 | 46.7  | 54.6 | 62.5 | 70.5 | 78.5 | 86.6 |
|               | 1868 | 39.6                 | 46.3 | 53.1 | 59.9 | 66.7 | 73.6 | 43.1  | 50.5 | 55.8 | 65.2 | 72.7 | 80.1 | 45.5  | 53.3 | 61.1 | 68.8 | 76.7 | 84.5 |
|               | 1728 | 38.3                 | 44.9 | 51.4 | 58.1 | 64.7 | 71.3 | 41.6  | 48.7 | 55.9 | 63.0 | 70.2 | 77.3 | 43.9  | 51.3 | 58.8 | 66.3 | 73.8 | 81.4 |
| Water Temp.   |      | 130                  | 140  | 150  | 160  | 170  | 180  | 130   | 140  | 150  | 160  | 170  | 180  | 130   | 140  | 150  | 160  | 170  | 180  |
|               |      | 3 GPM                |      |      |      |      |      | 4 GPM |      |      |      |      |      | 5 GPM |      |      |      |      |      |

## Dimensions & Clearances

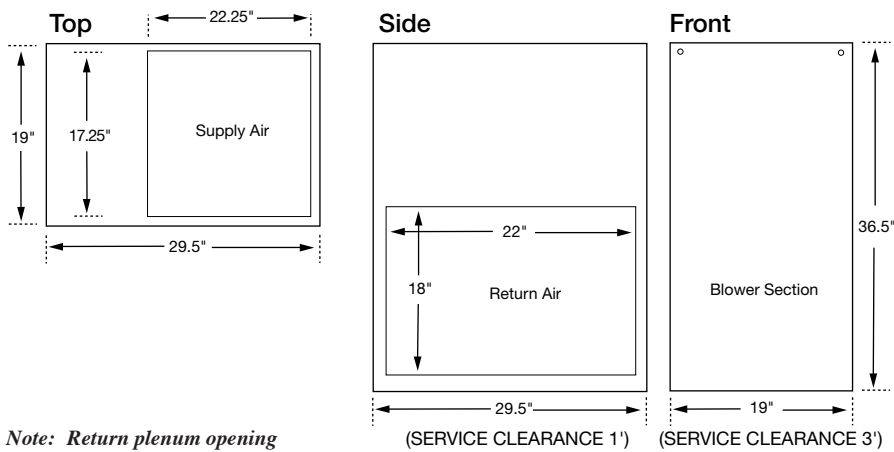

| Model             | AH80BHW                         |
|-------------------|---------------------------------|
| Voltage           | 120 VAC 60 Hz                   |
| Hp                | 1/2                             |
| Amps (total)      | 8.7                             |
| Water Connections | 1/2" Copper Soldered Connection |
| Airflow (High)    | .25 in wg<br>.5 in. wg          |
|                   | 1967 CFM<br>1639 CFM            |
| Net Weight        | 135 lbs.                        |
| Shipping Weight   | 155 lbs.                        |

*Note: Return plenum opening available off either side of cabinet. All units conform to CSA and UL Standards*

## Warranty

Units carry a five year replacement parts warranty on all components.



# Installation

The purpose of this manual is to give the contractor guidelines for installing the LIFE BREATH Air Handler. All national and local codes relating to this type of equipment must be followed.

## Locating The Unit

The Air Handler is designed to be installed vertically, in a conditioned space, **where the surrounding temperature does not fall below 50°F (10°C)**. Attic installations are not recommended. Typically the unit is installed in a mechanical area of the basement, or other partitioned mechanical room, elsewhere in the home.

Sufficient clearance around the unit is required for service of the filter and components. As a rule, this unit should be installed adjacent to the hot water heater. If this is not possible, or if the piping layout is complex, the total head pressure on the pump should be calculated.

## Duct Connections

To accommodate various installations, the Air Handler has knockouts for the return air plenum on both sides of the cabinet. Special care and attention should be given to determining which knockouts are to be removed.

Penetrations from sheet metal screws used to fasten the ductwork to the cabinet of the unit should only be placed into the duct flange provided. This is to avoid contact and damage of the heating/air conditioning coils and internal wiring.

## Ducting

The duct sizing for the furnace section can be determined using HRAI Residential Air System Design Manual, SMACNA, or any other industry-recognized manuals.

*Note: "Combo units" normally deliver air at approx. 110°F (43°C), and therefore may require larger than normal ductwork. When installing the Air Handler as a replacement unit on a retrofit application, always calculate the size of duct that is there.*

Any ductwork running through unconditioned space must be sealed properly and insulated to prevent heat loss. All local codes must be followed in determining the amount of insulation needed.

## Piping

The hot water piping between the hot water tank and the Air Handler should be new copper type, and should not be treated with chemicals, sealant or anything else, that will interfere with the purity of the potable water. Only non-lead, low temperature solder is permitted for sealing copper joints. The copper soldered pipe size for each model is:

|       |         |              |
|-------|---------|--------------|
| Model | AH40DHW | 1/2" nominal |
|       | AH60DHW | 3/4" nominal |
|       | AH40BHW | 1/2" nominal |
|       | AH60BHW | 1/2" nominal |
|       | AH80BHW | 1/2" nominal |

Where possible the length of pipe should not exceed 200' total equivalent length. Any piping running through unconditioned space must be insulated to prevent heat loss, and possible freezing of the line. Stickers indicating direction of flow, **(Supply to furnace, and Return to water heater)** are labeled on the outside of the cabinet. Do not reverse these lines, as this will cause the unit to malfunction.

For piping conventional water heaters or boilers, connections to and from the Air Handler to the heater should be made at the point where the pipes leave the heater vertically. A "T" fitting used in each vertical line, with the Air Handler piping connected to the horizontal side of this fitting, will work best in avoiding air locks in the circulation pump of the furnace.

*\*Note: Remove all shipping packaging and discard.*

# Plumbing

In order to improve serviceability of our products, the check valve is included with our manual kit for field installation between the air-handler and hot water source.

The check valve should be installed in a vertical run of pipe with the flow of water in an upward direction.

An arrow on the check valve indicates its correct orientation and must match the direction of water flow.

This will allow for ease of service to remove any installation debris or service required due to extended hard water conditions.

*Note: Take care during soldering to avoid debris or solder from lodging in the check valve.*

*Note: It is critical to follow the piping configuration shown. Maintain a minimum distance of 12" above the CAF/AH. This will minimize thermal siphoning in the combo system.*

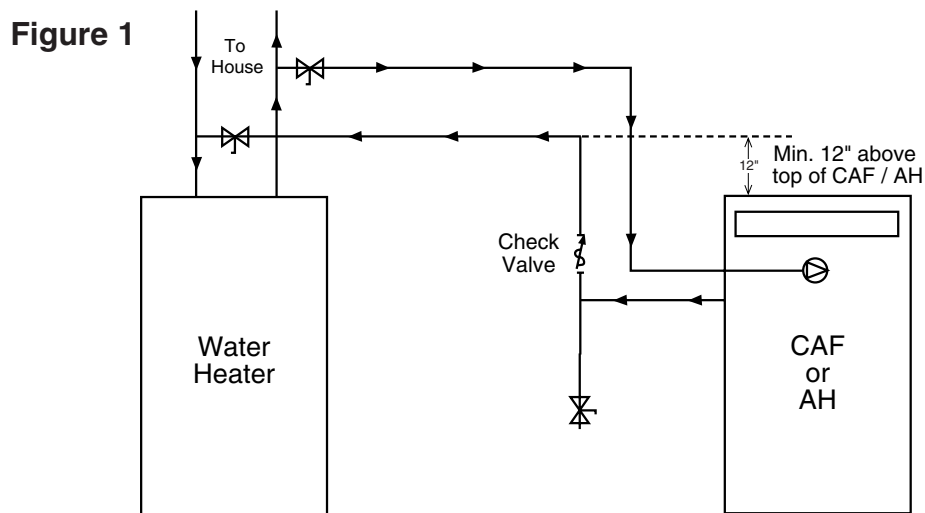

**Figure 2**

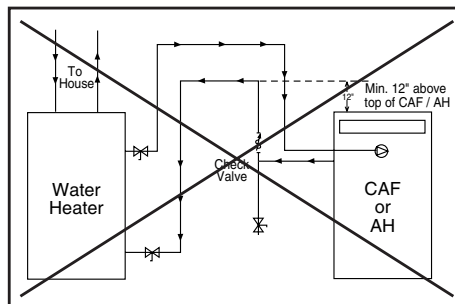

*\* It should be noted that problems have been observed when using the side tappings on certain water heaters; therefore, it is strongly recommended to use the top water tappings as indicated in Figure 1 to minimize thermal siphoning and related issues.*

*For further information, please contact Technical Support (519) 457-1904.*

# Electrical

The Air Handler operates at 120V, singles phase and draws anywhere from 2-8.7 amps, depending on fan speed.

The low voltage thermostat (not provided) connects to the R & W terminals for heating and the R & Y & C terminals when calling for cooling.

Caution should be used if installing a setback thermostat to control the system. If the thermostat is set back too far, and, for example, is set to call for a lot of heat when you get out of bed, at which time showering and general water use is at its peak, then the hot water heater may not keep up.

## Air Handler - Wiring Diagram

- R - W = Heat
- R - G = Fan Only (optional dehumidistat)
- G - R - Y - C = A/C

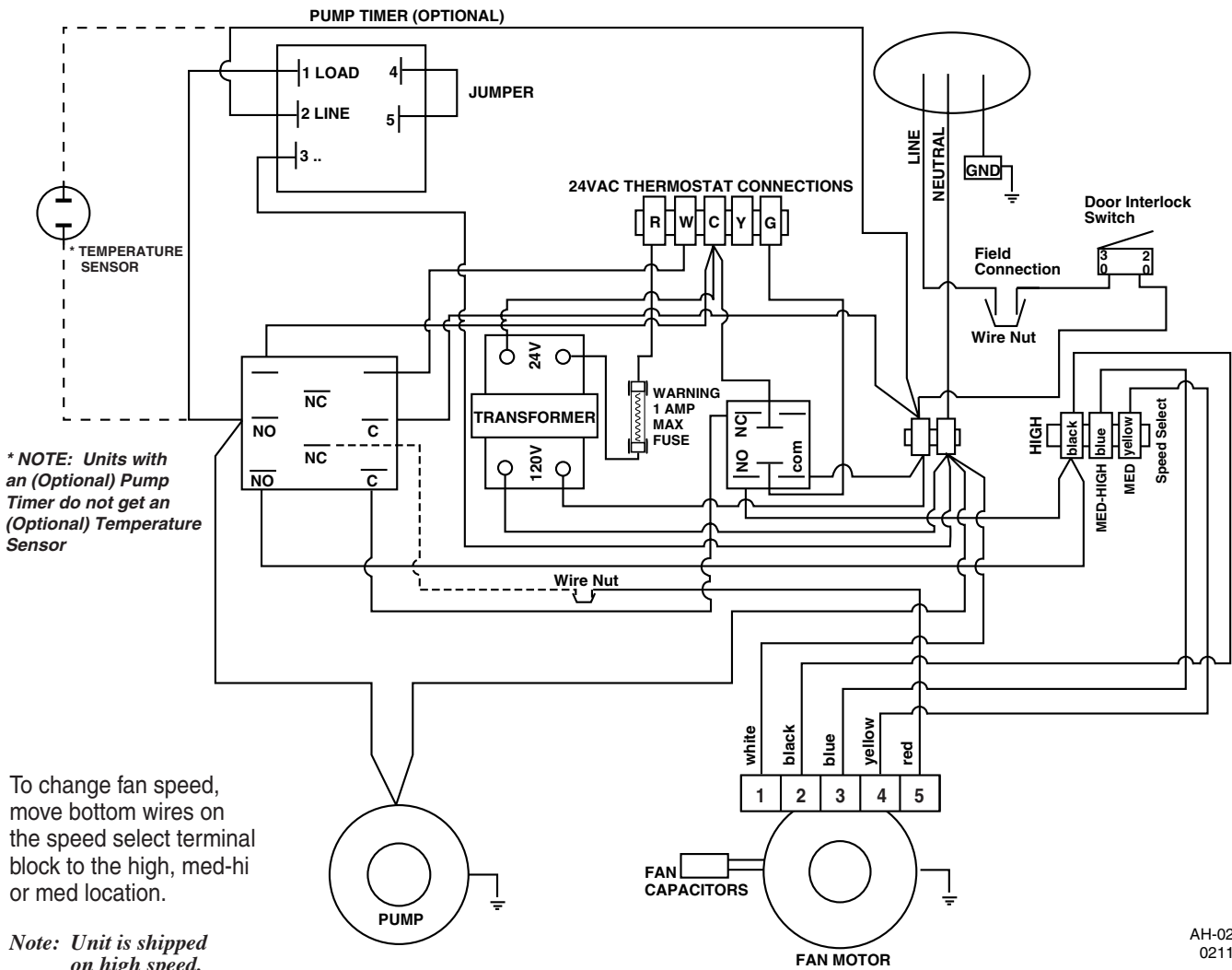

AH-02  
0211

# Optional Dehumidistat

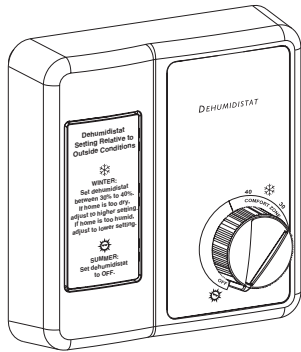

Part # 99-130W

An optional dehumidistat can be connected to the furnace to help eliminate excessive moisture during the heating season. When the dehumidistat senses moisture in excess of the control setpoint, the blower will be overridden into high speed. This will increase the ventilation airflow and create a dehumidification affect. Typical settings are between 30-40 during the winter and OFF for all other seasons.

The dehumidistat will connect to R&G terminals on the furnace.

**Note: Do not use dehumidistat for hot southern climates.**

**When using a Dehumidistat or Interface Relay to initiate high speed blower operation on a furnace, certain thermostats will initiate the outdoor cooling condenser when R and G are closed.**

Use this wiring configuration to stop the Dehumidistat from initializing the condenser unit. This problem can occur at the thermostat because the **Y** terminal is connected to the **G** terminal internal to the stat. When **R** and **G** are closed at the furnace (by dehumidistat or relay) 24 Volts is sent to **G** at thermostat. 24 Volts is then sent through **Y** which will initiate outdoor condenser. The relay will isolate this problem.

**NOTE: This problem does not occur with all thermostats, therefore it is important to fully commission the installation to determine if this relay configuration is required.**

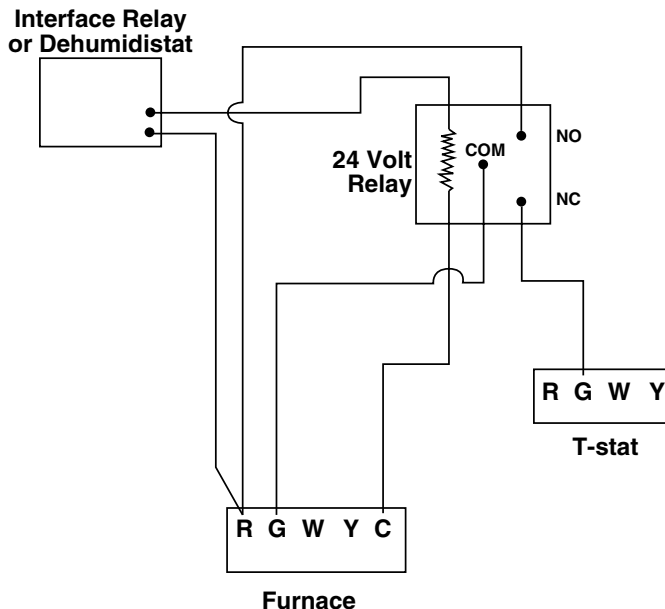

# Start-Up Procedure

In order for any appliance to work properly it must be set up and tested by a knowledgeable technician.

## The following conditions must be met prior to start-up

1. Ensure that connecting water lines are purged and free of debris  
*Caution: solder or other debris may cause the furnace pump or check valve to malfunction*
2. Blower wheel rotates freely inside its housing
3. Wiring connections are tight
4. All duct and pipe connections are sealed
5. Check that all packaging is removed
6. Front access door is on tight.
7. Fan speed selection:  
**Heating/Cooling** - factory setting is at high speed and can be changed in the electrical box to medium-high or medium if required.

## Once all of the necessary connections have been made, the Air Handler Start-Up Procedure is as follows:

1. Close shut-off valves separating the Air Handler from the water heater/boiler.
2. Set up water heater/boiler according to manufacturer's instructions.
3. Purge air from unit. To do so, open the supply shut-off valve to the furnace. Attach a garden hose to drain valve, and drain water until you get a continuous flow. Close the drain valve and purge the pump. To purge the air from the pump, turn the large screw on the face of the pump counterclockwise until water leaks out, then tighten. Open the supply shut-off valve.
4. Turn on power supply to Air Handler. **Caution: blower will start to operate.**
5. Switch the room thermostat to heat. The thermostat should be set higher than the current room temperature in order to energize the pump and commence the heating cycle. (If the pump does not start, or the Air Handler is not producing heat, refer to the Troubleshooting Section in this manual.
6. Set room thermostat at desired temperature setting.

# Operation

## Heating/Cooling

When the room thermostat calls for heat from the water heater, it activates a circulation pump located inside the Air Handler. This pump delivers hot water through the furnace coil and back to the water tank/boiler. Simultaneously, the furnace blower switches on to high speed and will start circulating air across the coil, which picks up heat and delivers it to the rest of your home.

Once the thermostat's temperature is reached, the pump will shut off, and the blower will return to its pre-set speed or off.

*Note: When the furnace blower is left running on low speed, the air in the home circulates continuously. When the heat is called for, the blower will automatically switch to a higher speed. After the required hot air has been delivered, the blower will switch back to low speed.*

When the thermostat calls for cooling (optional A coil and condensing unit required) the furnace blower activates to high speed and the outdoor condenser unit is energized. After the thermostat temperature is reached, the condensing unit will shut off, and the blower will return to its continuous setting. Continuous low speed can be selected by a qualified electrician.

## Optional Circulation Timer Models

Some models are equipped with a circulation timer. It is normal operation for these models to automatically run the circulation pump for a short period of time intermittently.

## Continuous Low Speed Hook Up

Continuous low speed can be selected by connecting the red wire from the blower to the N/C contact on the relay as indicated on the wiring diagram.

# Troubleshooting

## Lack of heat

1. Check that the room thermostat is set to the desired temperature.
2. Confirm the units have power and the shut-off valves are open.
3. Ensure there is power to the unit and that the pump is working. If the pump is not working properly, it may be stuck. Disconnect power and remove screw in center face of the pump. Using a screwdriver, turn the pump shaft several times to free it from sticking. Replace center-screw and re-connect power. If pump still fails to start, it may require replacement.
4. Confirm that the hot water heater is working and that hot water is entering the Air Handler.
5. Verify that the airflow in and out of the system matches designed specs. If airflow is low, check for blockage in the filter or some other obstruction.
6. Make sure your water heater is sized large enough for heat load of house and for domestic hot water use.
7. Air may still be in the water lines. If so, re-purge the system according to the start up procedure.
8. Confirm that the inlet and outlet pipe connections are not reversed.
9. Ensure that there are no other restrictions in the water lines, such as faulty valves or debris.

## Pump is noisy

Pumps can become noisy when air remaining in the lines interfere with their operation. If this occurs, re-purge the system as indicated in the Start-Up Procedure.

## During cooling cycle, hot water circulates through the coil

If the check valve inside the cabinet is stuck in the open position, hot water may infiltrate the heating coil. This occurs when the hot pipes are not capped-off during installation or service and foreign debris enters the piping. This debris can settle under the check valve seat and permit hot water to flow into the coil. The problem can be corrected by repeatedly flushing the heating loop until it is clean.

# System Commissioning

This section of the manual is designed to be used with the “Commissioning of Integrated Combo System” worksheet. The worksheet is designed to guide you through the start-up process in a logical, step by step method which should minimize the work and time involved in having the system meet the designed parameters.

The following conditions are assumed:

- The air filter is in place
- All supply diffusers and return grilles are fully open and unrestrictive
- Hot water is available to the furnace
- The drain valve for the heating loop is closed
- The shut off valves for the heating loop are

fully open

- The throttling valve for the heating loop (if applicable), is fully opened
- Electrical power is available at the furnace
- The return air temperature from the house is approximately 70°F (21°C)

## Water Pump Performance Specifications

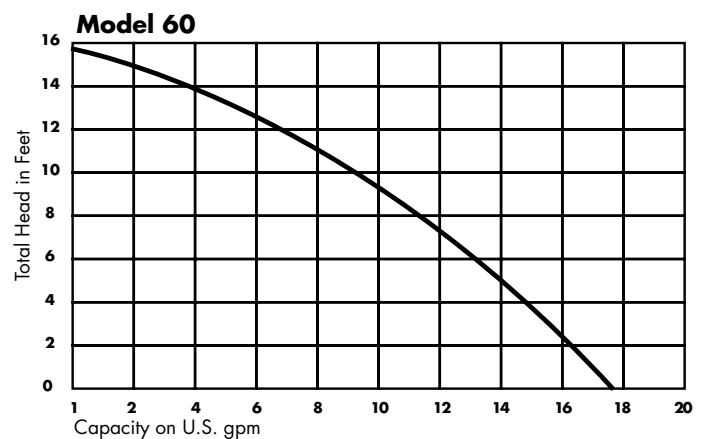
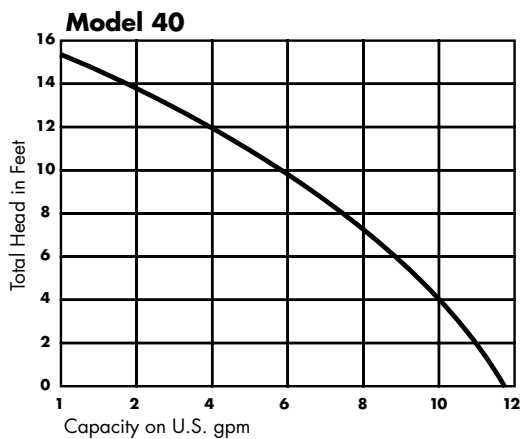



# WORKSHEET FOR INTEGRATED COMBO SYSTEM DESIGN



*Training Courses and Forms  
are available from  
HRAI Skill Tech Academy  
1-800-267-2231*

Designer/Signature: \_\_\_\_\_

Phone ( ) \_\_\_\_\_ Fax ( ) \_\_\_\_\_ Date: D \_\_\_\_ M \_\_\_\_ Y \_\_\_\_

|   |   |
|---|---|
| <p><b>Submitted For: (Owner)</b></p> <p>Name _____</p> <p>Address _____</p> <p>City _____ Prov. _____</p> <p>Postal Code _____</p> <p>Phone ( ) _____ Fax ( ) _____</p> | <p><b>By: (Contractor)</b></p> <p>Name _____</p> <p>Address _____</p> <p>City _____ Prov. _____</p> <p>Postal Code _____</p> <p>Phone ( ) _____ Fax ( ) _____</p> |
|---|---|

| DESIGNED EQUIPMENT              |  | DESIGNED EQUIPMENT (Cooling) |  |
|---------------------------------|--|------------------------------|--|
| Back Flow Prevention Valve      |  | Central Air Conditioner      |  |
| Expansion Tank                  |  | Heat Pump                    |  |
| Anti-scald Valve                |  | <b>VENTILATION SYSTEM</b>    |  |
| Throttle Valve                  |  | HRV                          |  |
| Off Season Circulation Controls |  | ERV                          |  |
| Other                           |  | Other                        |  |

## Part A - DESIGN LOAD SPECIFICATIONS

|                                 |                                 |
|---------------------------------|---------------------------------|
| A.1 Total Heat Loss _____ Btu/h | A.2 Total Heat Gain _____ Btu/h |
|---------------------------------|---------------------------------|

## Part B - EQUIPMENT SELECTION (Air Handler and Cooling)

|   |  |
|---|--|
| <p><b>AIR HANDLER:</b><br/>                 Make: <i>LIFEBREATH</i> Model: _____</p> <p>B.1 Heating Output _____ Btu/h<br/> <i>(110% - 140% of A.1)</i></p> <p>B.2 Equipment External Static Pressure _____ ins. W.C.<br/> <i>(from specs)</i></p> <p>B.3 Heating Air Flow Rate _____ cfm</p> <p>B.4 Circulation Fan Speed (Heating) _____ speed</p> <p>B.5 Return Air Temperature _____ °F</p> <p>B.6 Air Handler Temperature Rise _____ °F<br/> <i>[B.1 ÷ (1.08 x B.3)]</i></p> <p>B.7 Supply Air Temperature _____ °F<br/> <i>(B.5 + B.6)</i></p> <p>B.8 Water Supply Rate _____ US GPM<br/> <i>(from specs)</i></p> | <p>B.9 Water Supply Temperature _____ °F</p> <p>B.10 Water Temperature Drop _____ °F (min. 20°F)<br/> <i>[B.1 ÷ (500.4 x B.8)]</i></p> <p>B.11 Water Return Temperature _____ °F<br/> <i>(B.9 - B.10)</i></p> <p><b>COOLING EQUIPMENT:</b></p> <p>B.12 Cooling Output _____ (Btu/h) _____ tons<br/> <i>(80% - 125% of A.2)</i></p> <p>B.13 Manufacturers Flow Rate/Ton _____ (cfm/ton)</p> <p>B.14 Cooling Air Flow Rate _____ cfm</p> <p>B.15 Circulation Fan Speed (Cooling) _____ speed</p> |
|---|--|

## Part C - EQUIPMENT SELECTION (Water Heater)

|   |  |
|---|--|
| <p><b>DOMESTIC HOT WATER REQUIREMENTS:</b></p> <p>C.1 Minimum Storage Capacity _____ USG<br/> <i>(from page 27, Method A)</i></p> <p style="text-align: center;"><b>or</b></p> <p>C.2 Minimum First Hour Rating _____ USG<br/> <i>(from page 27, Method B)</i></p> <p><b>SPACE HEATING REQUIREMENTS:</b></p> <p>C.3 Minimum Effective Water Heater Output _____ Btu/h<br/> <i>(B.1 x 1.2)</i></p> | <p><b>SELECTED WATER HEATER:</b><br/>                 Make: _____ Model: _____</p> <p>C.4 Storage Capacity _____ USG</p> <p><i>Note: Complete C.5 and C.6 only if C.2 was completed.</i></p> <p>C.5 Recovery _____ USG</p> <p>C.6 First Hour Rating _____ USG<br/> <i>(.85 x (C.4 + C.5)) (min. C.2)</i></p> <p>C.7 Energy Factor (ef) _____</p> <p>C.8 Burner Input _____ Btu/h</p> <p>C.9 Recovery Efficiency _____ %</p> <p>C.10 Effective Water Heater Output _____ Btu/h<br/> <i>(C.8 x C.9 ÷ 100) (min. C.3)</i></p> |
|---|--|

### METHOD A - (domestic hot water usage for C.1)

**TABLE A 1 (NATURAL GAS AND PROPANE)\***

| No. of Bathrooms        | 1 to 1.5 |    |    | 2 to 2.5 |    |    |    | 3 to 3.5 |    |    |    |
|-------------------------|----------|----|----|----------|----|----|----|----------|----|----|----|
| No. of Bedrooms         | 1**      | 2  | 3  | 2        | 3  | 4  | 5  | 3        | 4  | 5  | 6  |
| Nominal Tank Size (USG) | 30       | 40 | 50 | 50       | 50 | 50 | 60 | 50       | 60 | 60 | 75 |

**TABLE A 2 (OIL)\***

| No. of Bathrooms        | 1 to 1.5 |    |    | 2 to 2.5 |    |    |    | 3 to 3.5 |    |    |    |
|-------------------------|----------|----|----|----------|----|----|----|----------|----|----|----|
| No. of Bedrooms         | 1**      | 2  | 3  | 2        | 3  | 4  | 5  | 3        | 4  | 5  | 6  |
| Nominal Tank Size (USG) | 32       | 32 | 32 | 32       | 32 | 50 | 50 | 32       | 50 | 50 | 50 |

\* *Not suitable for luxury or high volume applications*

\*\* *If laundry is ensuite for a one bedroom dwelling, increase tank size to 40 USG*

### METHOD B - (domestic hot water usage for C.2)

| Activity                             | Average Volume per usage - USG |                | X | Times used in Peak Hour | = | Peak hr Usage - USG |
|--------------------------------------|--------------------------------|----------------|---|-------------------------|---|---------------------|
| Shower                               | Hi-Flow (old)                  | Low-Flow (new) |   |                         |   |                     |
| 5 min.                               | 15                             | 4              | X |                         | = |                     |
| 10 min.                              | 30                             | 7              | X |                         | = |                     |
| 15 min.                              | 43                             | 11             | X |                         | = |                     |
| Bath Tub 1/2 full                    | 21                             |                | X |                         | = |                     |
| Whirl Pool (60% tub cap.)            | from manufacturer              |                | X |                         | = |                     |
| Personal Use                         | 3                              |                | X |                         | = |                     |
| Shampooing Hair                      | 5                              |                | X |                         | = |                     |
| Clothes Washer hot/warm              | 40                             |                | X |                         | = |                     |
| warm/warm                            | 27                             |                | X |                         | = |                     |
| warm/cold                            | 20                             |                | X |                         | = |                     |
| Hand Dish Washing                    | 4                              |                | X |                         | = |                     |
| Automatic Dish Washer                | 18                             |                | X |                         | = |                     |
| Food Preparation                     | 6                              |                | X |                         | = |                     |
| Other                                |                                |                | X |                         | = |                     |
| <b>TOTAL</b> (min. first hr. rating) |                                |                |   | (transfer to C.2)       | = |                     |

## PART D - PROVING REQUIRED WATER FLOW

|  |   |       |          |         |   |    |          |       |   |       |         |       |   |       |         |       |   |       |         |       |   |       |         |       |   |       |         |       |   |       |         |                          |  |  |       |                        |  |  |       |   |  |
|--|---|-------|----------|---------|---|----|----------|-------|---|-------|---------|-------|---|-------|---------|-------|---|-------|---------|-------|---|-------|---------|-------|---|-------|---------|-------|---|-------|---------|--------------------------|--|--|-------|------------------------|--|--|-------|---|--|
| <b>D.1 Effective Length Calculation</b><br><table style="width: 100%; border-collapse: collapse;"> <tr> <td style="text-align: center;">Fitting</td> <td style="text-align: center;">#</td> <td style="text-align: center;">EL</td> <td style="text-align: center;">Total EL</td> </tr> <tr> <td>_____</td> <td style="text-align: center;">x</td> <td>_____</td> <td>= _____</td> </tr> <tr> <td>_____</td> <td style="text-align: center;">x</td> <td>_____</td> <td>= _____</td> </tr> <tr> <td>_____</td> <td style="text-align: center;">x</td> <td>_____</td> <td>= _____</td> </tr> <tr> <td>_____</td> <td style="text-align: center;">x</td> <td>_____</td> <td>= _____</td> </tr> <tr> <td>_____</td> <td style="text-align: center;">x</td> <td>_____</td> <td>= _____</td> </tr> <tr> <td>_____</td> <td style="text-align: center;">x</td> <td>_____</td> <td>= _____</td> </tr> <tr> <td>Measured (Actual) Length</td> <td></td> <td></td> <td>_____</td> </tr> <tr> <td>Total Effective Length</td> <td></td> <td></td> <td>_____</td> </tr> </table> |   |       |          | Fitting | # | EL | Total EL | _____ | x | _____ | = _____ | _____ | x | _____ | = _____ | _____ | x | _____ | = _____ | _____ | x | _____ | = _____ | _____ | x | _____ | = _____ | _____ | x | _____ | = _____ | Measured (Actual) Length |  |  | _____ | Total Effective Length |  |  | _____ | <b>PUMP:</b><br>D.2 Water Flow Rate _____ US GPM<br>D.3 Max. Head Press. at Water Flow _____ ft of head<br><i>(from specs)</i><br>D.4 Pressure Drop of Water Coil _____ <b>5</b> ft of head<br>D.5 Available Head Press. _____ ft of head<br><i>(D.3 - D.4)</i><br>D.6 Total Effective Length _____ eff. ft<br><i>(from D.1)</i><br>D.7 Head Loss /100 ft _____ per 100 ft<br><i>(D.5 x 100 ÷ D.6)</i><br>D.8 Pipe Diameter _____ in.<br><i>(Table D 2)</i> |  |
| Fitting  | # | EL    | Total EL |         |   |    |          |       |   |       |         |       |   |       |         |       |   |       |         |       |   |       |         |       |   |       |         |       |   |       |         |                          |  |  |       |                        |  |  |       |   |  |
| _____  | x | _____ | = _____  |         |   |    |          |       |   |       |         |       |   |       |         |       |   |       |         |       |   |       |         |       |   |       |         |       |   |       |         |                          |  |  |       |                        |  |  |       |   |  |
| _____  | x | _____ | = _____  |         |   |    |          |       |   |       |         |       |   |       |         |       |   |       |         |       |   |       |         |       |   |       |         |       |   |       |         |                          |  |  |       |                        |  |  |       |   |  |
| _____  | x | _____ | = _____  |         |   |    |          |       |   |       |         |       |   |       |         |       |   |       |         |       |   |       |         |       |   |       |         |       |   |       |         |                          |  |  |       |                        |  |  |       |   |  |
| _____  | x | _____ | = _____  |         |   |    |          |       |   |       |         |       |   |       |         |       |   |       |         |       |   |       |         |       |   |       |         |       |   |       |         |                          |  |  |       |                        |  |  |       |   |  |
| _____  | x | _____ | = _____  |         |   |    |          |       |   |       |         |       |   |       |         |       |   |       |         |       |   |       |         |       |   |       |         |       |   |       |         |                          |  |  |       |                        |  |  |       |   |  |
| _____  | x | _____ | = _____  |         |   |    |          |       |   |       |         |       |   |       |         |       |   |       |         |       |   |       |         |       |   |       |         |       |   |       |         |                          |  |  |       |                        |  |  |       |   |  |
| Measured (Actual) Length   |   |       | _____    |         |   |    |          |       |   |       |         |       |   |       |         |       |   |       |         |       |   |       |         |       |   |       |         |       |   |       |         |                          |  |  |       |                        |  |  |       |   |  |
| Total Effective Length   |   |       | _____    |         |   |    |          |       |   |       |         |       |   |       |         |       |   |       |         |       |   |       |         |       |   |       |         |       |   |       |         |                          |  |  |       |                        |  |  |       |   |  |

**TABLE D 1 EQUIVALENT LENGTHS FOR COPPER PIPE FITTINGS (straight pipe in feet)**

| FITTING                  | EQUIVALENT LENGTH | FITTING                         | EQUIVALENT LENGTH |
|--------------------------|-------------------|---------------------------------|-------------------|
| Gate / Ball Valve (open) | 1                 | long sweep 90° elbow            | 2                 |
| Globe Valve (open)       | 23                | 45° elbow                       | 1                 |
| Angle Valve (open)       | 12                | 180° close return               | 6                 |
| Check Valve (open)       | 6                 | standard tee (straight through) | 2                 |
| Balance Valve            | 18                | standard tee (90° turn)         | 5                 |
| Standard Elbow           | 3                 | contraction or enlargement      | 2                 |

**TABLE D 2 HEAD LOSS PER 100 FEET OF EQUIVALENT LENGTH**

|               | 1/2" inside diameter  | 5/8" inside diameter  | 3/4" inside diameter  | 1" inside diameter     |
|---------------|-----------------------|-----------------------|-----------------------|------------------------|
| FLOW (US GPM) | HEAD LOSS (FT./100FT) | HEAD LOSS (FT./100FT) | HEAD LOSS (FT./100FT) | HEAD LOSS (FT./100FT.) |
| 1             | 3                     | 2                     | 1                     | *                      |
| 1.5           | 6                     | 4                     | 1                     | *                      |
| 2             | 9                     | 7                     | 2                     | *                      |
| 2.5           | 14                    | 9                     | 3                     | *                      |
| 3             | 19                    | 13                    | 4                     | 1                      |
| 3.5           | 25                    | 17                    | 5                     | 1                      |
| 4             | 32                    | 22                    | 6                     | 1                      |
| 4.5           | 39                    | 27                    | 7                     | 2                      |
| 5             | *                     | 33                    | 9                     | 2                      |
| 6             | *                     | 45                    | 12                    | 3                      |
| 7             | *                     | *                     | 16                    | 4                      |
| 8             | *                     | *                     | 21                    | 5                      |
| 9             | *                     | *                     | 26                    | 6                      |
| 10            | *                     | *                     | 31                    | 8                      |

## COMMISSIONING OF INTEGRATED COMBO SYSTEM



*Training Courses and Forms  
are available from  
HRAI Skill Tech Academy  
1-800-267-2231*

Designer/Signature: \_\_\_\_\_

Phone ( ) \_\_\_\_\_ Fax ( ) \_\_\_\_\_ Date: D \_\_\_\_ M \_\_\_\_ Y \_\_\_\_

**Submitted For: (Owner)**

Name \_\_\_\_\_

Address \_\_\_\_\_

City \_\_\_\_\_ Prov. \_\_\_\_\_

Postal Code \_\_\_\_\_

Phone ( ) \_\_\_\_\_ Fax ( ) \_\_\_\_\_

**By: (Contractor)**

Name \_\_\_\_\_

Address \_\_\_\_\_

City \_\_\_\_\_ Prov. \_\_\_\_\_

Postal Code \_\_\_\_\_

Phone ( ) \_\_\_\_\_ Fax ( ) \_\_\_\_\_

### INSTALLED EQUIPMENT

|                                       |  |                                 |  |
|---------------------------------------|--|---------------------------------|--|
| Water Heater make & model as designed |  | Throttling Valve                |  |
| Air Handler make & model as designed  |  | Anti-scalding Valve             |  |
| Cooling Unit make & model as designed |  | Back Flow Prevention Valve      |  |
| Filter type and size as designed      |  | Expansion Tank                  |  |
| 2 shut off valves for heating loop    |  | Off Season Circulation Controls |  |
| Check Valve                           |  | Other                           |  |
| Drain Valve                           |  |                                 |  |

### Part E - SYSTEM START UP

|  |  |
|--|--|
| E.1 Fill Water Heater with water <span style="float: right;"><input type="checkbox"/></span>             | E.5 Start Air Handler <span style="float: right;"><input type="checkbox"/></span>                |
| E.2 Set Water Heater at designed temperature <span style="float: right;"><input type="checkbox"/></span> | E.6 Check Circulation Pump Operation <span style="float: right;"><input type="checkbox"/></span> |
| E.3 Fill Heating Loop with water <span style="float: right;"><input type="checkbox"/></span>             | E.7 Check Circulation Fan Operation <span style="float: right;"><input type="checkbox"/></span>  |
| E.4 Purge Circulation Pump <span style="float: right;"><input type="checkbox"/></span>                   | E.8 Label Water Heater <span style="float: right;"><input type="checkbox"/></span>               |

### Part F - SYSTEM COMMISSIONING

**Design Information:** (Information for this section can be found on the "Worksheet for Integrated Combo System Design" part B)

Total Heat Loss \_\_\_\_\_ Btu/h      Air Handler: output \_\_\_\_\_ Btu/h      Eff. Water Heater output \_\_\_\_\_ Btu/h  
 Air Handler ESP: \_\_\_\_\_ ins. W.C.      Air Flow rate: \_\_\_\_\_ CFM      Fan speed \_\_\_\_\_  
 Supply Water temp.: \_\_\_\_\_ °F      Return Water temp.: \_\_\_\_\_ °F      Supply Air temp.: \_\_\_\_\_ °F      Return Air temp.: \_\_\_\_\_ °F

|   |   |
|---|---|
| F.1 Supply Water Temp. _____ °F<br><i>(measured)</i>                            | F.6 Required Supply Air Temperature _____ °F<br><i>(F.4 + F.5)</i>                  |
| F.2 Air Handler Output at F.1 Condition _____ Btu/h                             | F.7 Returned Water Temperature _____ °F<br><i>(measured)</i>                        |
| F.3 Air Handler Operating CFM _____ CFM<br><i>(from specs)</i>                  | F.8 Water Temperature Difference _____ °F (min. 20°F)<br><i>(F.1 - F.7)</i>         |
| F.4 Return Air Temperature _____ °F<br><i>(measured)</i>                        | F.9 Actual Supply Air Temperature _____ °F<br><i>(measured)</i>                     |
| F.5 Required Air Temperature Difference _____ °F<br><i>(F.2 ÷ (F.3 x 1.08))</i> | F.10 Anti-Scald Valve (if present) Outlet Temperature _____ °F<br><i>(measured)</i> |





511 McCormick Blvd.  
London, Ontario N5W 4C8  
T (519) 457-1904  
F (519) 457-1676  
Email: [nutech@lifebreath.com](mailto:nutech@lifebreath.com)

270 Regency Ridge, Suite 210  
Dayton, Ohio 45459  
T (937) 439-6676  
F (937) 439-6685  
Website: [www.lifebreath.com](http://www.lifebreath.com)

**ISO  
9001**  
REGISTERED