

E421/E421F E422/E422F FRYERS



INSTALLATION, SERVICING and USER INSTRUCTIONS

IMPORTANT

The installer must ensure that the installation of the appliance is in conformity with these instructions and National Regulations in force at the time of installation.

Particular attention **MUST** be paid to -

BS7671 IEE Wiring Regulations

Electricity at Work Regulations

Health And Safety At Work Act

Fire Precautions Act

This appliance has been CE-marked on the basis of compliance with the Low Voltage and EMC directives for the voltages stated on the data plate.

WARNING -THIS APPLIANCE MUST BE EARTHED

On completion of the installation these instructions should be left with the Engineer-in-Charge for reference during servicing. Further to this, The Users Instructions should be handed over to the User, having had a demonstration of the operation and cleaning of the appliance.

IT IS MOST IMPORTANT THAT THESE INSTRUCTIONS BE CONSULTED BEFORE INSTALLING AND COMMISSIONING THIS APPLIANCE. FAILURE TO COMPLY WITH THE SPECIFIED PROCEDURES MAY RESULT IN DAMAGE OR THE NEED FOR A SERVICE CALL.

PREVENTATIVE MAINTENANCE CONTRACT

In order to obtain maximum performance from this unit we would recommend that a Maintenance Contract be arranged with SERVICELINE. Visits may then be made at agreed intervals to carry out adjustments and repairs. A quotation will be given upon request to the SERVICELINE contact numbers below.



WEEE Directive Registration No. WEE/DC0059TT/PRO

At end of unit life, dispose of appliance and any replacement parts in a safe manner, via a licenced waste handler. Units are designed to be dismantled easily and recycling of all material is encouraged whenever practicable.

Falcon Foodservice Equipment

HEAD OFFICE AND WORKS

Wallace View, Hillfoots Road, Stirling. FK9 5PY. Scotland.

SERVICELINE CONTACT

Phone: 01438 363 000

Fax: 01438 369 900

T100798 Ref. 6

IMPORTANT INFORMATION

Warranty Policy Shortlist

Warranty does not cover :-

- Correcting faults caused by incorrect installation of a product.
- Where an engineer cannot gain access to a site or a product.
- Repeat commission visits.
- Replacement of any parts where damage has been caused by misuse.
- Engineer waiting time will be chargeable.
- Routine maintenance and cleaning.
- Gas conversions i.e. Natural to Propane gas.
- Descaling of water products and cleaning of water sensors where softeners/ conditioners are not fitted, or are fitted and not maintained.
- Blocked drains
- Independent steam generation systems.
- Gas, water and electrical supply external to unit.
- Light bulbs
- Re-installing vacuum in kettle jackets.
- Replacement of grill burner ceramics when damage has been clearly caused by misuse.
- Where an engineer finds no fault with a product that has been reported faulty.
- Re-setting or adjustment of thermostats when unit is operating to specification.
- Cleaning and unblocking of fryer filter systems due to customer misuse.
- Lubrication and adjustment of door catches.
- Cleaning and Maintenance
 - Cleaning of burner jets
 - Poor combustion caused by lack of cleaning
 - Lubrication of moving parts
 - Lubrication of gas cocks
 - Cleaning/adjustment of pilots
 - Correction of gas pressure to appliance.
 - Renewing of electric cable ends.
 - Replacement of fuses
 - Corrosion caused by use of chemical cleaners.

SECTION 1 - INSTALLATION

UNLESS OTHERWISE STATED, PARTS WHICH HAVE BEEN PROTECTED BY THE MANUFACTURER ARE NOT TO BE ADJUSTED BY THE INSTALLER.

Please ensure that any plastic coatings are removed prior to use. Before operation, the pan requires to be thoroughly cleaned and dried.

Discolouration of heated parts is caused by factory testing to ensure a satisfactory unit. It does not affect quality or performance.

1.1 MODEL NUMBERS, NETT WEIGHTS and DIMENSIONS

Model	Width (mm)	Depth (mm)	Height (mm)	Weight (kg)
E421 / E422	400	800	880	72
E421F / E422F	400	800	880	83

1.2 SITING

The unit must be installed on a firm level floor in a well-lit draught free position. The fryer should not be installed in a position where the possibility of sideways tipping is likely when force is applied. The means of restraint may be the manner of installation, such as connection to a battery of appliances or installing the fryer in an alcove, or by separate means, such as adequate ties.

1.2.1 Anti-tipping Bracket

An anti-tipping mechanism is also available as an accessory. If fitted, the brackets must be installed to locate the fryer in the correct position relative to any walls as detailed below. Fixing holes are provided in fryer base to accommodate the bracket. Details of fitting can be found in Figure 1 below. The retaining chain has a quick release eyelet. Attach securely to fixing point and secure bracket to floor after alignment with bracket attached to the fryer. Adjust bracket to slide below floor bracket.

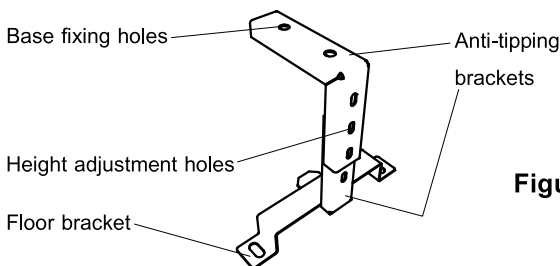

Figure 1

Figure 1 - Anti-tipping Bracket

1.2.2 Clearances

The unit requires a clearance of at least 100mm to the rear between unit and any combustible wall.

A minimum vertical clearance of 750mm should be allowed between top edge of flue outlet and any overlying combustible surface.

Important

If fryer is to be installed with other appliances then the instructions for each unit should be consulted to determine the necessary clearance to any combustible wall or overlying surface.

Some appliances require greater clearance distances than others. The largest clearance will therefore determine overall distance for a complete suite of adjoining appliances.

1.3 VENTILATION

The appliance ventilation requirements should be in line with national and local regulations.

For multiple installations, requirements should be added together. Installations should be made in accordance with local and/or national regulations applying at the time.

A competent engineer must be used for any installation work.

1.4 ELECTRICAL SUPPLY

The unit is supplied with a 2 metre, 5-core cord for connection to a 400V 3N~ supply incorporating a suitable isolating switch.

Phase Loading

L1: 29A, L2: 29A, L3: 29A

1.5 CABLE SUPPLY

A cable conforming to code designation 0245 IEC 57 (eg. H07RH-F5G4) must be used for connection to a 400V 3N~ supply incorporating a suitable isolating switch.

SECTION 2 - ASSEMBLY and COMMISSIONING

The electrical cable must be connected in accordance with the various regulations listed on the cover of this manual.

2.1 ASSEMBLY

- a) Unpack appliance
- b) Unpack fryer baskets and accessories.
- c) Place element guard and baskets in pan.
- d) Level appliance and fit all service protection kits. (*Anti-tilt kit, if ordered as accessory*).

2.2 CONNECTION TO AN ELECTRICAL SUPPLY

The supply cable must be connected to a suitable isolator switch as follows:

Phase 1: Brown, Phase 2: Black, Phase 3: Grey

Neutral: Blue, Earth: Green/Yellow

2.3 STARTING UP

2.3.1 E421F Fryer Control Panel (See Figure 2)

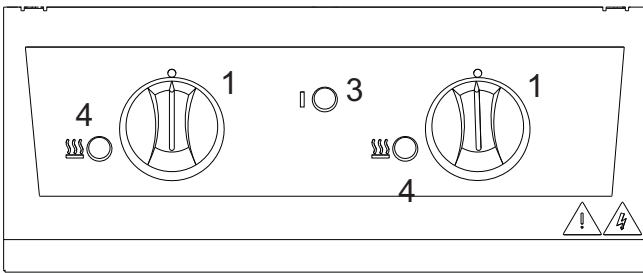

Figure 2 – E421F Control Panel

1. ON/OFF and Temperature Control Knob

Temperature Selection (140 - 190°C). (*Unit is off when in position indicated*).

2. Fat Melt Position

Feature for slow pulsed heating of solid fats.

3. Power on indicator.

4. Heat Demand Indicator (*Amber*)

illuminates when elements are on. Goes out when desired temperature is reached.

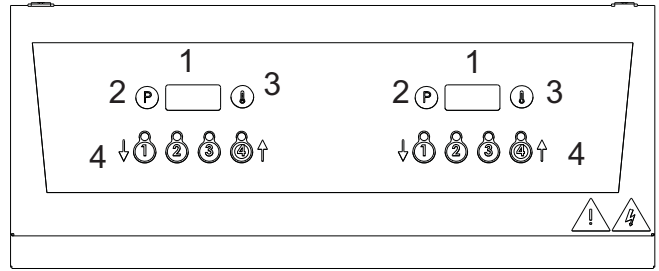

2.3.2 E422F Fryer Control Panel (See Figure 3)

Figure 3 – E422F Control Panel

1. Four Digit LED Display

Displays Set temp, Actual temp, cook time remaining and also used for programming purposes.

2. Program Button

Used to enter timer programme mode (*to change each of the 4 pre-set timer select channels*). (See Section 6).

3. Temperature Button

Used to view Actual/Set temperature and also to enter Set temperature mode (See Section 6).

4. Timer Keys (1 – 4)

Used to start/cancel pre set cook times. Buttons 1 & 4 also used to change times or temperatures when in either set mode (See Section 6).

5. Heat demand LED indicator

Illuminates when thermostat demands heat, i.e. oil temperature is more than 2°C below programmed set temperature. Will extinguish when desired setting is reached.

2.4 PRE-COMMISSIONING CHECK

2.4.1 Checking Controller Operation

To check operation of controls, refer to Using The Controller - Section 6.2.1.

2.4.2 E421F & E422F - Additional Controls (See Figure 4)

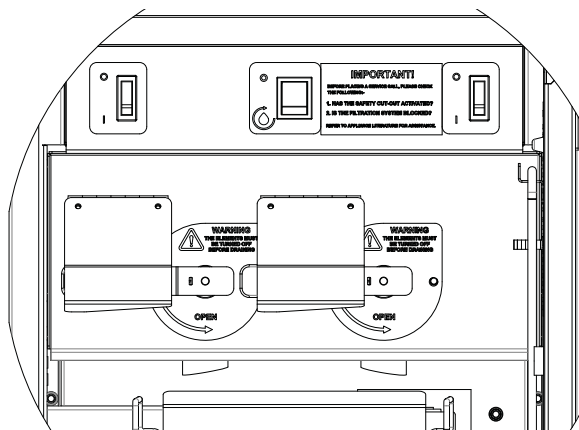

Figure 4 – E421F & E422F - Additional Controls

The following additional controls are located behind cabinet door.

Fryer Pan ON/OFF Switches

Both pans are controlled by individual on/off switches that cut power to appliance. Ensure both switches are off. These are located as detailed in Figure 4.

2.4.3 E421F & E422F - Additional Controls (See Figure 4)

Filtration Control

Filtration switch is located on centre of panel, behind cabinet door.

Ensure oil return pipe is located in quick-release valve housing.

Switch OFF appropriate on/off switch.

Switch ON filtration pump switch and allow oil to return into pan.

Close drain valve when oil is filtered and allow pan to fill.

Switch off filtration pump switch.

Temperature Safety Limiter Reset Button - 2 off

Located on rear of element box, below black dust cap, refer to Figure 5.

Figure 5

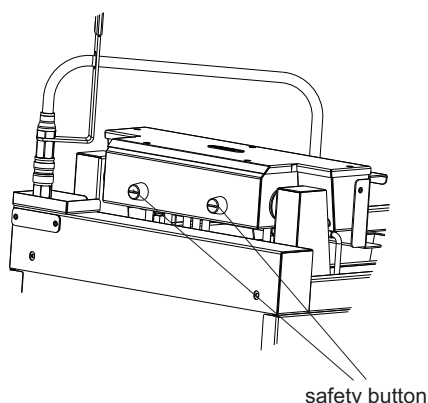

2.5 TEMPERATURE LIMIT THERMOSTAT

The unit is equipped with additional temperature limit thermostats, independent of the main controller.

In the case of operating thermostat failure, allowing oil temperature to rise above predetermined legislation safe zone (230°C), limit device will activate and cut power to controller and elements.

To re-set temperature limit thermostat: (Refer to Figure 5)

E421F and E422F Models

- Turn appropriate fryer pan ON/OFF switch to OFF position.
- Allow oil to cool below 150°C
- To reset limit thermostat, remove black dust cap located at element box rear. Push reset button using a blunt instrument. (*i.e. a pen*) and replace cap.
- Turn fryer ON/OFF switch to ON position.
- Reselect temperature.
- If limit thermostat reactivates carry out fault finding on temperature control circuitry.

2.6 INSTRUCTION TO INSTALLER

After installing and commissioning appliance, please hand Instructions to user or purchaser and ensure that the person(s) responsible understands the instructions to correctly operate and clean unit in a safe manner.

Emphasis should be given to safe operation and use of drain valve and oil bucket. Oil bucket should not be overfilled to allow safe movement. Oil should be allowed to cool before any manual handling.

Note: The oil container may be heavy. Drain small amounts at a time if necessary, before lifting container. Manual handling regulations should be observed.

SECTION 3 - SERVICING AND CONVERSION

BEFORE ATTEMPTING ANY SERVICING, TURN OFF THE ELECTRICAL SUPPLY. TAKE STEPS TO ENSURE THAT THESE CANNOT BE INADVERTENTLY TURNED ON.

AFTER ANY MAINTENANCE TASK, CHECK THE APPLIANCE TO ENSURE THAT IT PERFORMS SAFELY AND CORRECTLY AS DESCRIBED IN SECTION 2.4.

3.1 INTEGRAL COMPONENTS

The following parts must be checked and serviced regularly:

1. Oil ingress to electrical components.
2. Visual inspection of components and fryer pan.
3. Temperature limit thermostat calibration.

3.2 ACCESS PROCEDURES

Before removal of any fryer components:

- a) Ensure appliance electrical supply has been shut off and cannot be accidentally turned back on.
- b) Allow oil to cool before any operation that requires pan to be drained.
- c) Only use parts specified by the manufacturer.
- d) All components replaced MUST be fully checked after fitting to ensure safe operation.
- e) A full pre-commissioning check as detailed in Section 2.4 should be carried out.

3.3 ELEMENTS

- a) Remove five fixings from element box top and release element cables.
- b) Tilt element box and rest in upright position.
- c) Remove four fixings from element mounting plate.
- d) Remove element and seal.
- e) Replace in reverse order.

3.4 TEMPERATURE CONTROLLERS

- a) Remove control panel by undoing fixings at top and bottom. Unplug control panel.
- b) Disconnect electrics loom and remove fixings to enable controller to be removed.
- c) Carefully replace in reverse order.

3.5 MAINS ON and HEAT DEMAND NEONS

- a) Remove control panel by undoing fixings at top and bottom of control panel and unplug control panel.
- b) Remove electrical connections from neon. Undo neon retention nut.
- c) Carefully replace in reverse order.

3.6 DRAIN VALVE

- a) Ensure fry pot is empty. Refer to Section 8.
- b) Remove nut from handle and lift handle off.
- c) Remove front panel fasteners.
- d) Disconnect wiring, noting all connections.
- e) Remove front panel to access drain valve.
- f) Undo drain pipe. Use appropriate size of spanner to remove drain valve.
- g) Replace in reverse order and check for oil leaks.

3.7 TEMPERATURE LIMIT THERMOSTAT

- a) Remove element box cover plate.
- b) Lift elements and secure in raised position.
- c) Undo phial retention nut.
- d) Release phial from retaining clip.
- e) Disconnect phial wire plug and cut off plug.
- f) Pull down phial to remove.
- g) Carefully replace in reverse order. Check for any oil leaks and that thermostat calibration is within specification.

SECTION 4 - SPARES

When ordering spare parts, always quote appliance type and serial number. This information will be found on the data plate.

Manual control

Electronic controller

Element

Contactors

Solid State Relay

Operating thermostat

Safety thermostat

SECTION 5 - CRITICAL DIMENSIONS

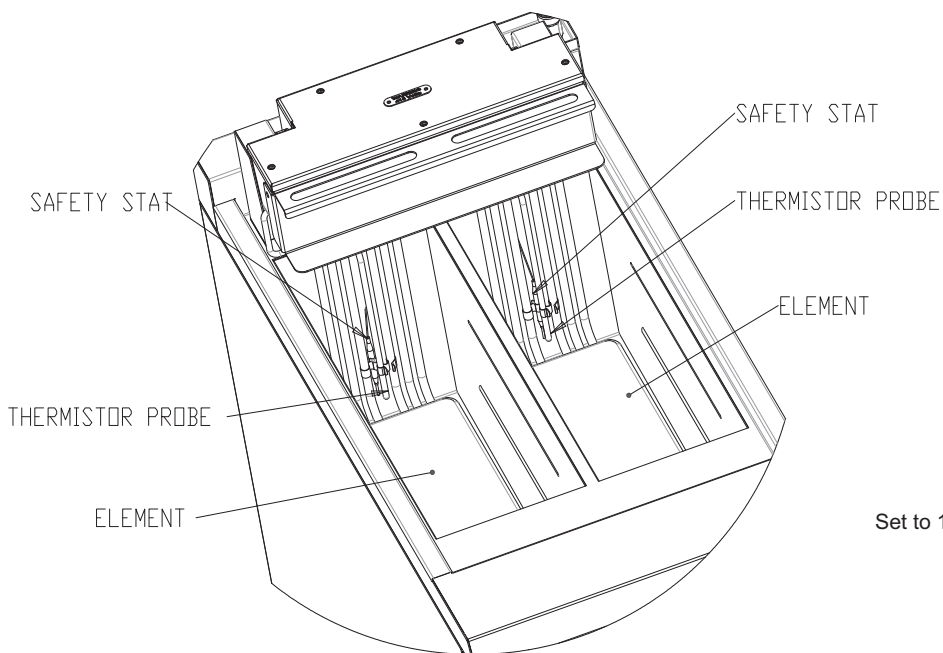

Timer Pump Settings

Set for 230V

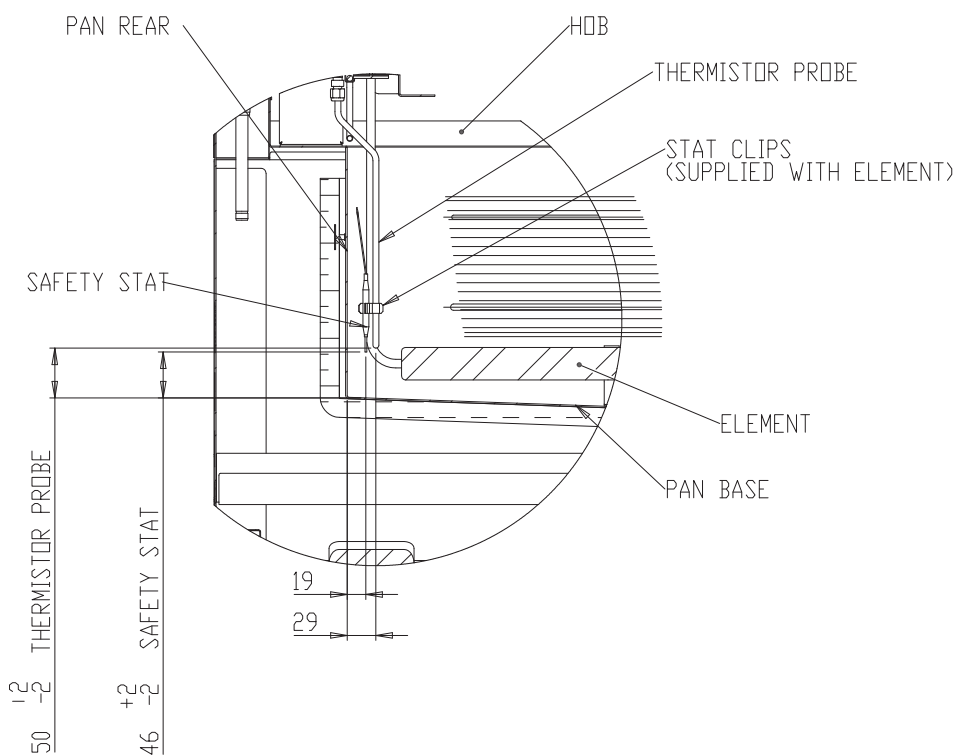
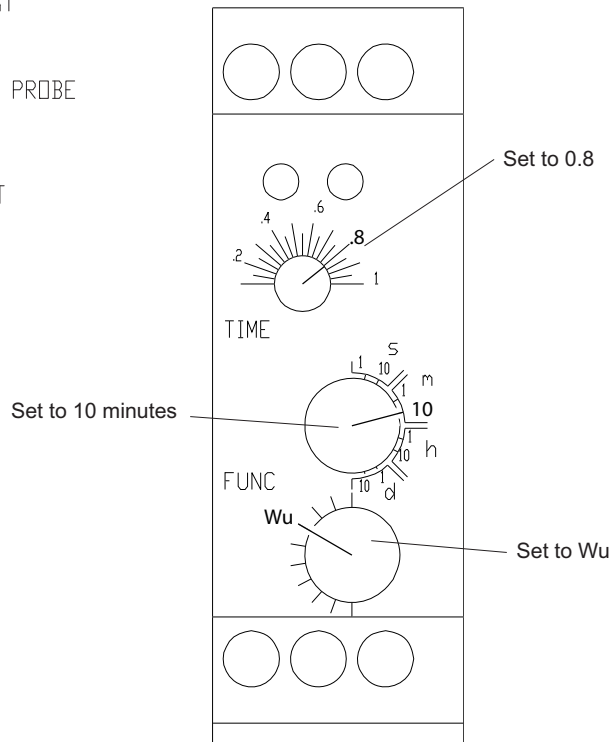

SECTION 6 - OPERATING INSTRUCTIONS

The fryers are of twin pan type and the following units are covered by this manual.

E421 - Manual control model.

E422 - Four product key electronic control model.

E421F - Manual control model with built-in filtration.

E422F - Four product key electronic control model with built-in filtration.

USE OF OIL / SHORTENING/SOLIDS (COOKING MEDIUM)

As these are highly flammable when in their liquid state, caution should always be taken when using cooking medium.

Recommendation

PPE's (*Personal Protective Equipment*) should be used when cleaning or handling medium within this fryer.

Medium should not be overheated as this will increase the risk of fire.

Note: Fryer is fitted with a thermal safety device. This will stop heating of medium if the medium becomes overheated.

This appliance will always fail safe.

Note: NEVER leave a working unit unattended.

Medium must always be maintained within fry pot.

Cold Medium - when filling with cold medium (*see Figure 6*), DO NOT FILL MEDIUM PAST - **MIN** - LEVEL MARK (*Maximum Cold Fill Mark*).

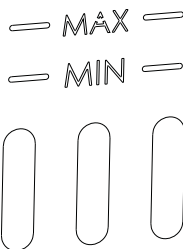

Figure 6

- **MIN - Level Mark:** Medium should NEVER be allowed to drop below this mark. Should medium drop below this mark, top up immediately or switch fryer OFF.

Hot Medium and Topping Up Medium

DO NOT FILL MEDIUM PAST - **MAX** - LEVEL MARK (*Maximum Hot Fill Mark*). (*See Figure 6*).

Medium and Foodstuffs

As foodstuffs increase volume within fry pot - follow these rules:

NEVER ADD WATER TO FRYER MEDIUM!

WARNING

No attempt must be made to operate appliance during a power supply failure.

Please ensure that any plastic coated items are removed prior to use. Before operation, pan requires to be thoroughly cleaned and dried.

Discolouration of heated parts is caused by factory testing to ensure unit is satisfactory. It will not affect quality or performance.

All Models

An electronic thermostat with temperature probe is fitted. The operating thermostat automatically controls oil temperature. The temperature limit thermostat ensures that the oil will not reach a dangerous temperature level.

If limit thermostat should activate during operation, an investigation to determine the reason must be carried out by a qualified technician.

6.1 APPLIANCE CONTROLS

Refer to Sections 2.4.1, 2.4.2 and 2.4.3 for controls layout and description.

6.2 OPERATION

Safety Precautions

The installer must fit an isolator switch on unit electrical supply.

The user MUST be familiar with location and operation of isolator switch for shutting off electrical supply in event of an emergency.

6.2.1 Frypot Filling Instructions

Remove lid (*if fitted*) and baskets and set these aside. Ensure pan is clean and completely dry. Ensure also that drain valve is closed. Pour clean, cold oil to - **MIN** - pan level mark on element guard/basket support grid.

Both Models (E421F/E422F)

- a) Press appropriate ON/OFF pan switch ON (I).
- b) Refer to individual unit info below.
- (i) **E421F only** - Turn knob to select temperature.
- (ii) **E422F only** - Is factory preset for a temperature of 180°C (See Section 6.3.1 for instructions on how to change set temperature).
- e) Refer to individual unit info below.
- (i) **E421F** - Heat demand indicator will illuminate.
- (ii) **E422F only** – Display will illuminate with figures **8888** for 2 seconds, **CTT** for 2 secs, **r 06** for 2 seconds and then displays **Louu**. Heat demand LED will illuminate.

6.2.2 Fryer maximum basket loading (Both models)

Pre-blanching chilled fries– **2 x 1.5kg baskets**.

Frozen fries – **2 x 1.2kg baskets**.

6.2.3 Using the Controller

E421F Models Only - Manually Operated

When unit has been switched on as detailed in Section 6.2.1 above, fryer may be operated as follows.

Oil temperature will be governed by controller to desired set temperature, selected by user on control knob.

E422F Models only – Programmable

When unit is lit as detailed in Section 6.2.1 lighting instructions above, fryer may be operated as follows:-

NOTES:

- 1) The oil temperature will be governed by controller at a factory preset temperature of 180°C. See Section 6.3.1 for details of how to change set temperature.
- 2) When actual temperature is within 10°C of set point, display indicates **redy**. See Section 7.3 for details of how to display actual or set temperature.
- 3) Before carrying out any cooking operations, controller should be set up for particular application of use (e.g. up to four timer programmes, product frying temperature, °C/°F). This can all be carried out using the following guide in Section 6.3.2.

Operating the Controller:

- a) **To start a timing cycle:** Press any product key (1 to 4) to start a timing cycle. If key is programmed, correct time will display and will immediately start to count down. LED above key will flash. DONE will display when cook cycle ends and alarm will sound. If DONE is displayed immediately and alarm sounds, key has not been programmed See Section 6.3.2 for programming details.
- b) **To stop a timing cycle:** Press and hold an active product key for 3 seconds, or press key 3 times within 2 seconds.
- c) Respond to a **DONE** alarm: Cancel signal by pressing same product key used to start timing cycle.
- d) **Multiple timing cycles:** If a second or third product key is pressed while first is still active, shortest time remaining key is displayed and only LED above key flashes, other(s) remain constantly lit. Once shortest time programme ends and is accepted, next shortest is displayed and LED above flashes. **Note:** All product key timers will count down although not displayed until shorter one ends.
- e) **Action Alarms (Shake, etc.):** If control is programmed for action alarm, this will signal at a pre-set time during timing cycle. The signal, a dual-rhythm beeping, will last 5 seconds and then self-cancel. The display will flash action alarm time and will continue counting towards **0:00**.
- f) **Viewing Actual / Set Temperatures:** Press temperature key once to display “**Axxx**” where xxx is actual temperature (°C or °F depending on controller programming, see Section 6.3.1). Press temperature key again within 5 seconds to display “**Pxxx**” where xxx is programmed set temperature controller (°C or °F depending on how controller is programmed – See Section 6.3.1). If temperature key is not pressed again within 5 seconds, display returns to idle or timer mode.

6.3 PROGRAMMING THE E422F

Display Descriptions

Louu

Controller is in operating mode. Actual vat temperature is more than 10°C below programmed vat temperature.

rEdy

Controller is in operating mode. Actual vat temperature is within proper cooking temperature range. The vat is ready to start a cook cycle.

HI

Controller is in operating mode. Actual vat temperature is more than 10°C above programmed vat temperature.

Prob

Control probe is either open circuited or short circuited. Display will be accompanied by an audible alarm if shorted. Check or replace probe.

2:30

The control is in operating mode and a cook cycle is in progress.

done

The control is in operating mode and a cook cycle has been completed. Display will be accompanied by a pulsing audible alarm.

6.3.1 Programming temperature set point and temperature scale. (Factory set for 180°C, range available is 30°C to 190°C)

- Press and hold temperature key for 3 seconds. **“Prog”** will be displayed. Then press DOWN (key 1) or UP (key 4) key.
- The display will show either **“°C”** or **“°F”** (degrees celsius or degrees fahrenheit). Once desired temperature scale is displayed, press temperature key to accept/enter.
- Display will now alternate between **“Sett”** and **“XXXZ”** (where X denotes temperature and Z indicates temperature scale).
- Adjust temperature using DOWN (key 1) and UP (key 4) keys. The longer key is pressed, the faster temperature scrolls.
- When desired temperature has been reached, press temperature key to accept/enter.
- To exit temperature programming, press temperature key again.

6.3.2 Programming a Product Cycle Time and Action Alarm

- Press and hold **P** key for 3 seconds. **“Prog”** will be displayed. **Note:** Programming mode will exit automatically if no keys are pressed within 2 minutes.
- Select a product key to program (1 to 4). The display will alternate between **“ti-z”** and **“X:XX”** where **z** is the number of key pressed and **X:XX** is set time in minutes and seconds.
- Adjust the time up or down using the **DOWN** (key 1) and the **UP** (key 4) keys. The longer key is held, the faster time will scroll.
- When set time is reached, press **P** key to accept/enter.
- The display will now alternate between **“PrEz”** and **“X:XX”** where **z** is number of key pressed and **X:XX** is action alarm time in minutes and seconds.
NOTE: The time entered here is time action required before end of total cycle time entered above. If NO action time is required, leave at **“0:00”**. Adjust time as c) above.
- Once desired time is reached, press **P** key to accept/enter.
- “Prog”** will again be displayed and another product key can be selected for programming. Repeat above steps. When no more keys are required to be programmed and **“Prog”** is displayed, press **P** key to exit programming mode and return to idle mode.

SECTION 7 - CHANGING THE OIL

Warning

After filtering, wait 30 seconds before removing bucket.

When draining, ensure that oil has time to strain through strainer basket. Heavily unfiltered oil may overflow.

Warning

If oil is not emptied on a regular basis or if oil is left in receptacle, it may solidify and overflow or spill on to the kitchen floor to create a hazard.

7.1 STARTING THE FILTRATION PROCESS

- Turn unit off at appropriate ON/OFF pan switch and allow oil to cool below 170°C (or if cold, heat to minimum temperature of 60°C). Open cabinet door and pull filter bucket forward.

2. Ensure bucket is clean and emptied of all oil and debris. Refer to Section 8 for details of how to clean filter components.
3. Ensure strainer and microfilter are clean and dry.
4. With strainer and microfilter in position, slide bucket back on to runner cradle and back into fryer to engage with pump.

Please Note

Warning

Do not handle filter components or adjacent surfaces when pump is operating.

Components will remain hot for a period after filtering. Allow to cool. Use of PPE's is recommended.

7.1.1 E421F and E422F Models

Note: With cabinet door open, filter pump switch is in centre of control panel. (Refer to Figure 4).

1. Ensure appropriate appliance pan on/off switch is in OFF position.
 2. Allow oil to cool for approximately 15 - 20 minutes.
 3. Position bucket and filters and ensure these are clean and dry.
 4. Open drain valve.
 5. Allow oil to drain from pan.
 6. Remove element guard from pan.
 7. Raise elements with the aid of element lifting tool.
- Please note: Elements and guard may still be hot!**
8. Remove any fringed debris from pan.
 9. Lower elements.
 10. Activate oil pump by means of filter pump switch to return oil to pan.
 11. Leave to cycle for a few minutes before closing drain valve.
 12. Allow pan to fill with oil.
 13. Once oil has been returned to pan, switch oil pump off by means of filter pump switch.
 14. Replace element guard.
 15. Top up oil to correct level.

SECTION 8 - CLEANING and MAINTENANCE

RECOMMENDATION

Personal protective equipment (*PPE's*) should be used when cleaning or handling medium within this appliance.

WARNING - NEVER PUMP WATER THROUGH THE FILTRATION PUMP AT ANY TIME!

Warning

The fryer is supplied with castors at rear and should be connected to supply piping by means of a connector for moveable appliances. An anti-tipping restraint can be attached to unit and, if so, this must be disconnected before fryer is moved. Ensure restraint is re-connected when unit is returned to original position.

Moving the unit with hot or cold oil in fry pot can be dangerous to the operator. Scalding could occur. Spilled oil or fat on a kitchen floor could cause slipping accidents and any such deposit should be cleaned up straight away.

To prevent any such hazard, DO NOT move fryer until all liquid has been drained from fry pot.

The following procedure should be undertaken, AT LEAST DAILY.

IMPORTANT: Disconnect electrical supply before any cleaning is undertaken.

Warning

Oil must be allowed to cool to a safe temperature before draining. Do not overfill draining receptacle.

THE APPLIANCE MUST NOT BE CLEANED WITH A JET OF WATER OR BE STEAM CLEANED. DO NOT USE ACID OR HALOGEN-BASED (*e.g. chlorine*) DESCALING LIQUIDS, FLAMMABLE LIQUIDS, CLEANING AIDS OR CLEANING POWDERS.

Stainless Steel Surfaces

It should be noted that certain scouring pads including nylon types, could easily mark stainless steel. Care should be exercised during cleaning process.

When rubbing stainless steel with a cloth, always rub along in grain direction.

8.1 CLEANING THE APPLIANCE

1. Carry out actions as detailed in Section 8.
2. Switch unit off and drain oil from appropriate pan.
3. Remove baskets and element guard. Soak these components in hot soapy water.
4. Raise elements using tool provided (*located behind unit door*). Rest elements on rear support bar.
5. With drain valve open, remove any traces of debris from fry pot using a clean, damp cloth.

NOTE: Care should be taken not to damage sensors that are secured to elements.

6. Remove strainer and microfilter, soak these in hot soapy water.
7. Wash, rinse and dry removed items thoroughly. Set these aside.
8. Close drain valve.
9. Fill fry pot 3/4 full with hot water.
10. Clean pan using a soft, clean cloth and hot soapy water, rub away any stubborn staining with a scouring pad and suitable detergent.
11. Open drain valve. Allow water to drain into bucket below.
12. Use clean water to rinse fry pot and dry thoroughly.
13. Close drain valve.
14. Lower elements back into fry pot and replace element guard and baskets.
15. Remove oil bucket by pulling forward then upward.
16. Use handles and lift oil bucket to sink.
17. Pour away soiled water.
18. Thoroughly wash, rinse and dry oil bucket and oil suction pipe.
19. Replace strainer and micro-filter in oil bucket and return oil bucket to cradle.
20. Fill fry pot with clean oil to - **MIN** - mark. Refer to Section 7.2.

SECTION 9 - PREPARATION OF SOLID FATS/SHORTENING

COOKING HINTS

Allow approximately 6 minutes for unit to heat up from cold to required operating temperature.

Choice of Frying Medium

Select a top quality medium to obtain optimum results. Shortening or solid fats can be used if necessary. Solid fats **MUST** be heated carefully. Solid fat has a lower smoke point temperature than shortening.

E421F fat melt cycle pulses heat into the fryer.

A quality shortening is a more stable frying medium. It allows longer periods of use without smoking or foaming and will also give food a better flavour. Quality shortening has a higher flashpoint temperature and will reduce gumming around the appliance.

WARNING - NEVER MIX SHORTENING AND SOLID FAT!

Charging The Pan

Prior to operation, clean fry pot out using hot water and detergent. Rinse out and dry thoroughly.

Ensure drain valve is closed. Fill fry pot with cold shortening to - **MIN** - level mark on element guard.

Maximum oil level capacity is 2 x 10 litres.

Solid Fat

If solid fat is to be used, remove element guard. Cut fat into small pieces. Place 9.2kg in each fry pot and pack it down. Position element guard on top of fat. Ensure FAT MELT CYCLE (*E421F only*) is selected for this process.

Note

The element guard will lower slowly as solid fat melts.

Warning

If element guard does not lie flat, lift plate from centre slightly and lower carefully ensuring that no splashing of hot oil occurs.

Check that correct shortening level is achieved when all solid fat has melted. The required temperature may then be set.

Solid fat should always be heated this way to prevent overheating and burning.

WARNING: It is dangerous to use shortening that is too old. Such shortening has a reduced flash point temperature and is prone to surge boiling.

CAUTION: To prevent surge boiling. **DO NOT EXCEED** recommended loads or charge the pan with over-wet food items. **NEVER** leave a working appliance unattended.

SECTION 10 - COOKING HINTS

Frying food involves many variables and the following information is a guide only.

1. Ensure frying medium is clean and free of debris.
2. When topping up with oil, ensure oil level does not exceed - **MIN** - when cold and - **MAX** - line when hot.
3. Never overfill baskets with food product.
4. Filter oil as often as is practically possible. Remember, this can be done whilst oil is below 180°C.
5. It is advised that a skimmer is used continuously between frying batches of food to remove any floating debris. Failure to do this may result in oil becoming bitter to taste.
6. During quiet spells, it is recommended that thermostat is turned down to a lower setting. This will conserve energy in addition to extending expected oil life.
7. To ensure a good eating experience, fry food as close to serving time as possible.
8. After serving and when fryer has been turned off, replace lid to ensure that no foreign bodies can contaminate frying medium.

WIRING DIAGRAM for E421

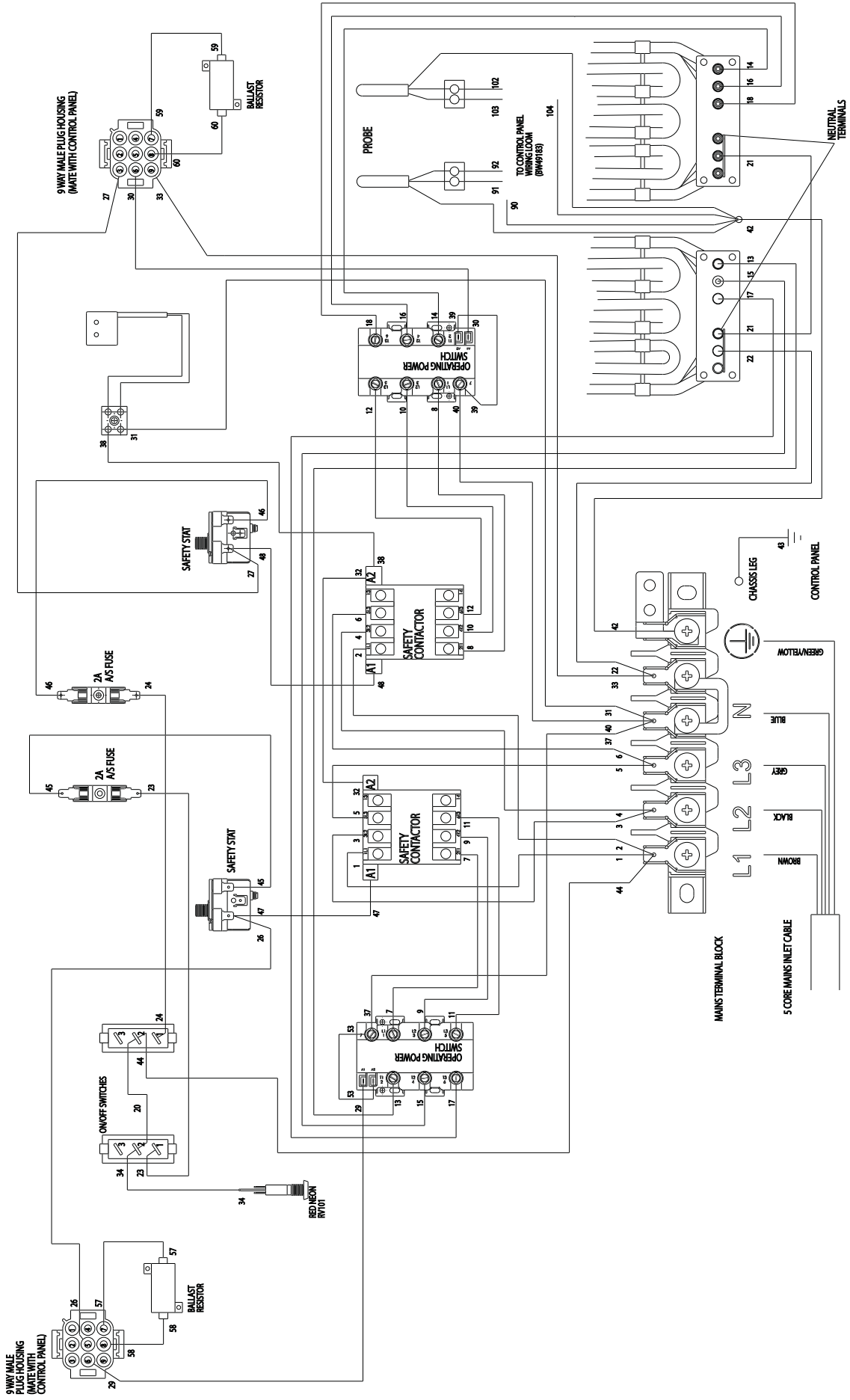

9 WAY MALE
PLUG HOUSING
(MATE WITH CONTROL PANEL)

26 27 28 29 30 31 32 33 34 35

BALLAST
RESISTOR

57 58 59 60

ON/OFF SWITCHES

20 21 22 23 24

34 35 36 37 38

RED NEON
RNY01

SAFETY SWITCH

26 27 28 29 30 31 32 33 34 35

2A
A5 FUSE

46 47 48 49 50 51 52 53 54 55

SAFETY CONTACTOR

A1 A2

1 2 3 4 5 6 7 8 9 10 11 12 13 14 15 16 17 18

OPERATING POWER
SWITCH

8 9 10 11 12 13 14 15 16 17 18 19 20 21 22 23 24 25 26 27 28 29 30 31 32 33 34 35 36 37 38 39 40 41 42 43 44 45 46 47 48 49 50 51 52 53 54 55 56 57 58 59 60

PROBE

90 91 92 102 104

TO CONTROL PANEL
WIRING HARNESS
(BYPASS)

104

NEUTRAL
TERMINALS

21 22 23 24 25 26 27 28 29 30 31 32 33 34 35 36 37 38 39 40 41 42 43 44 45 46 47 48 49 50 51 52 53 54 55 56 57 58 59 60

MAINS TERMINAL BLOCK

L1 L2 L3 N

5 CORE MAINS INLET CABLE

BROWN

BLACK

GREY

BLUE

GREEN/YELLOW

CHASSIS LEG

CONTROL PANEL

48

WIRING DIAGRAM for E422

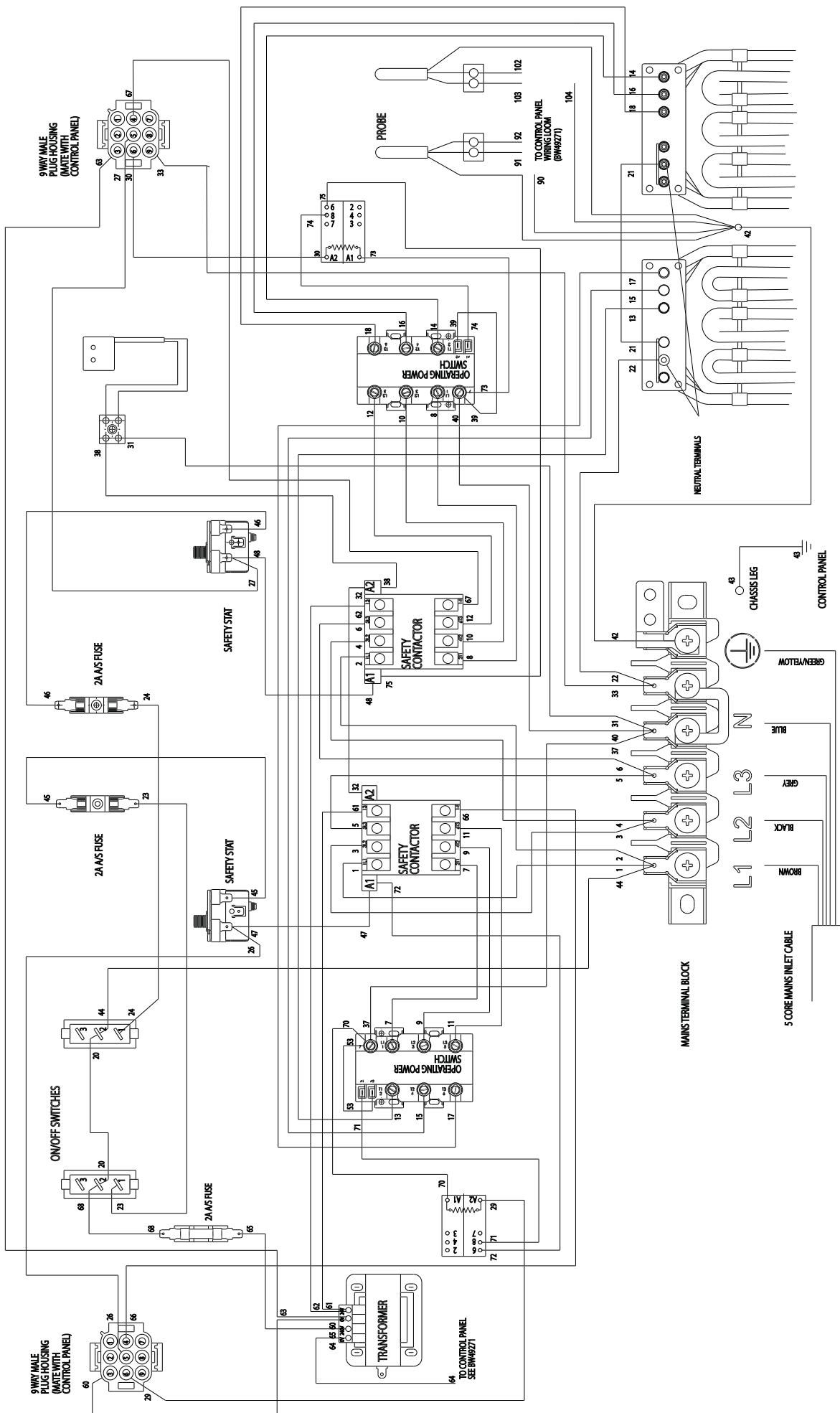

WIRING DIAGRAM for E421F

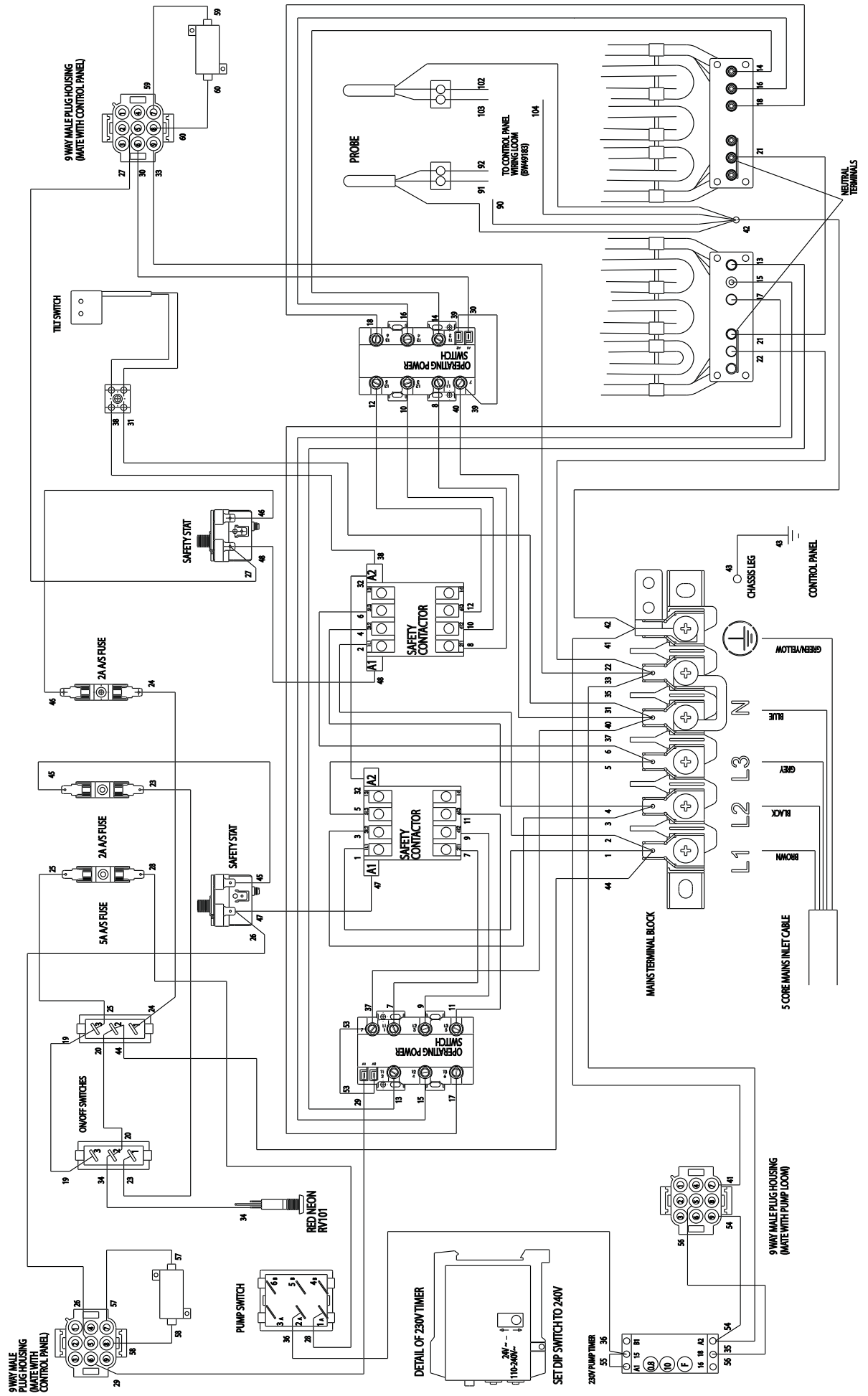

WIRING DIAGRAM for E422F

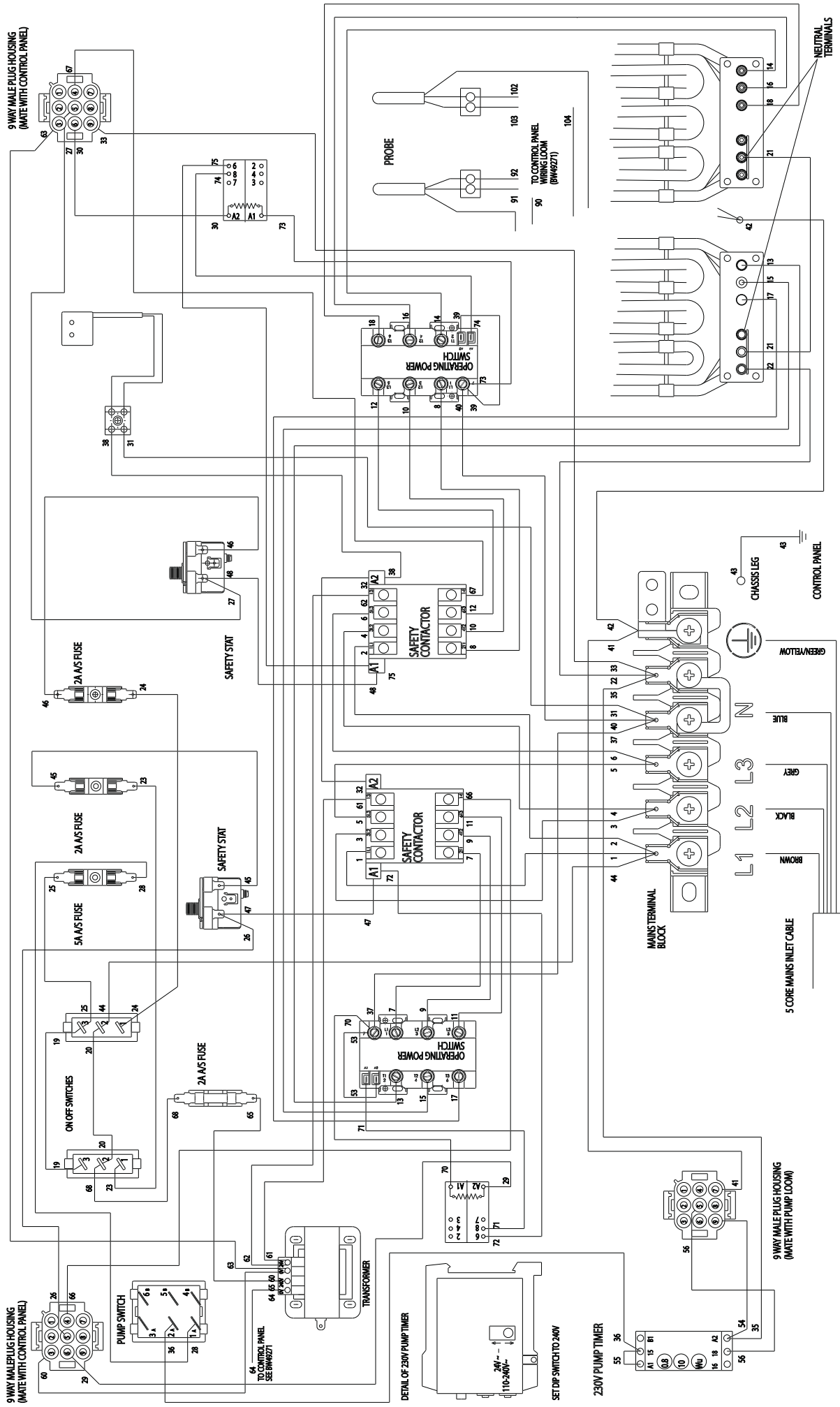

E421/421F Control Panel Wiring Diagram

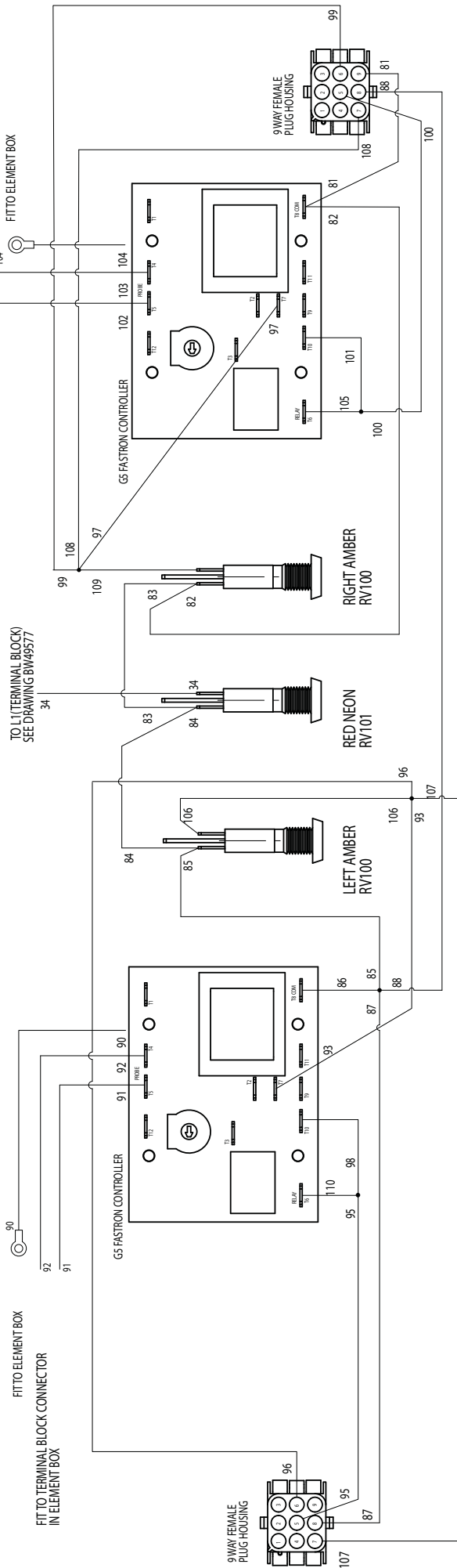

E422/422F Control Panel Wiring Diagram

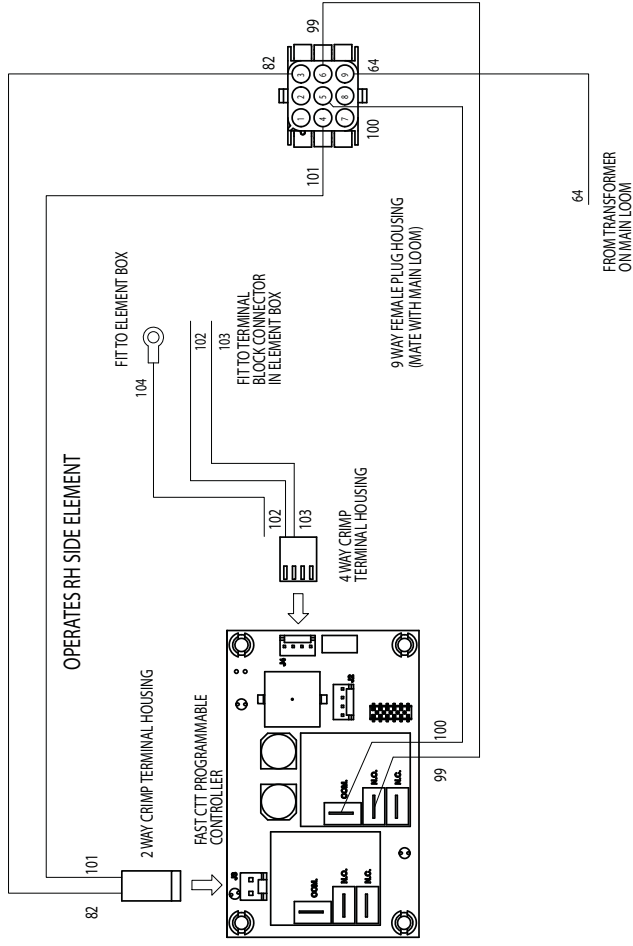
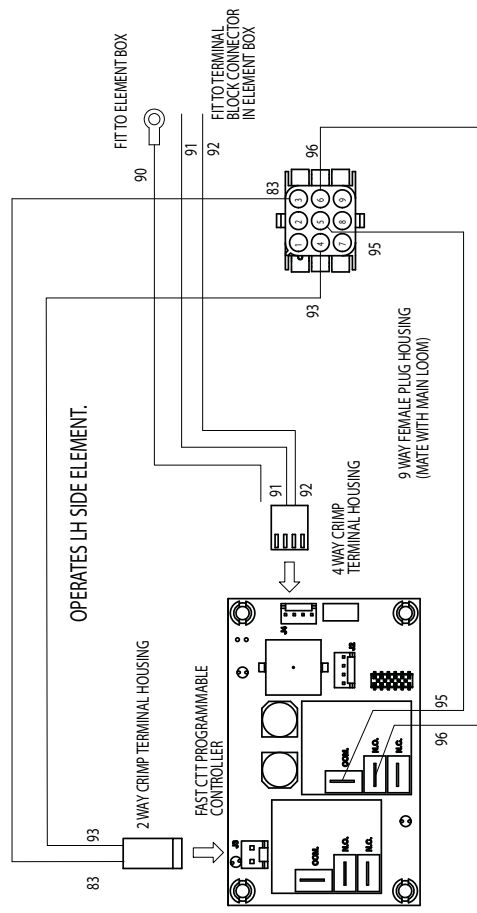

CIRCUIT DIAGRAM for E421

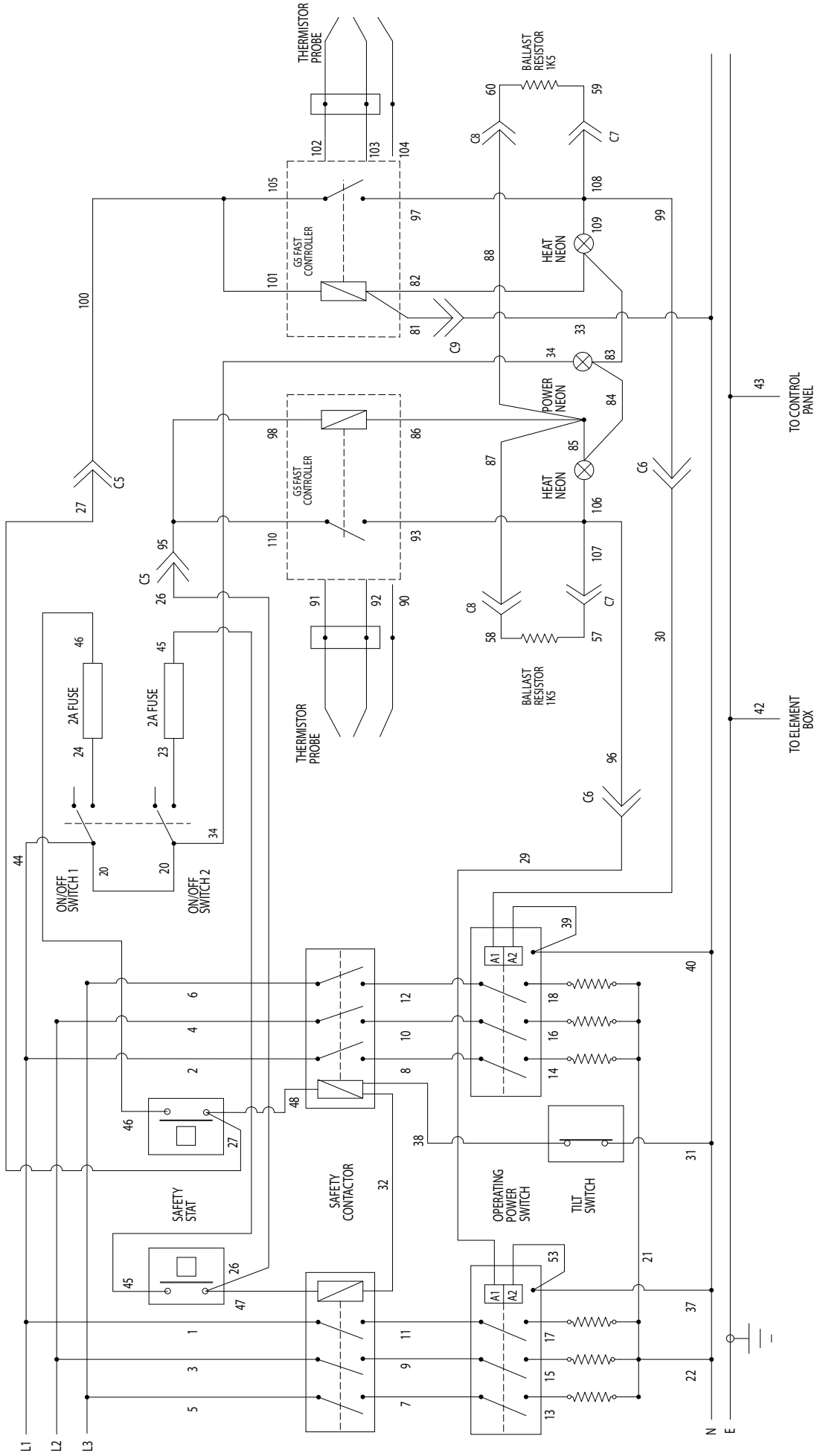

CIRCUIT DIAGRAM for E421F

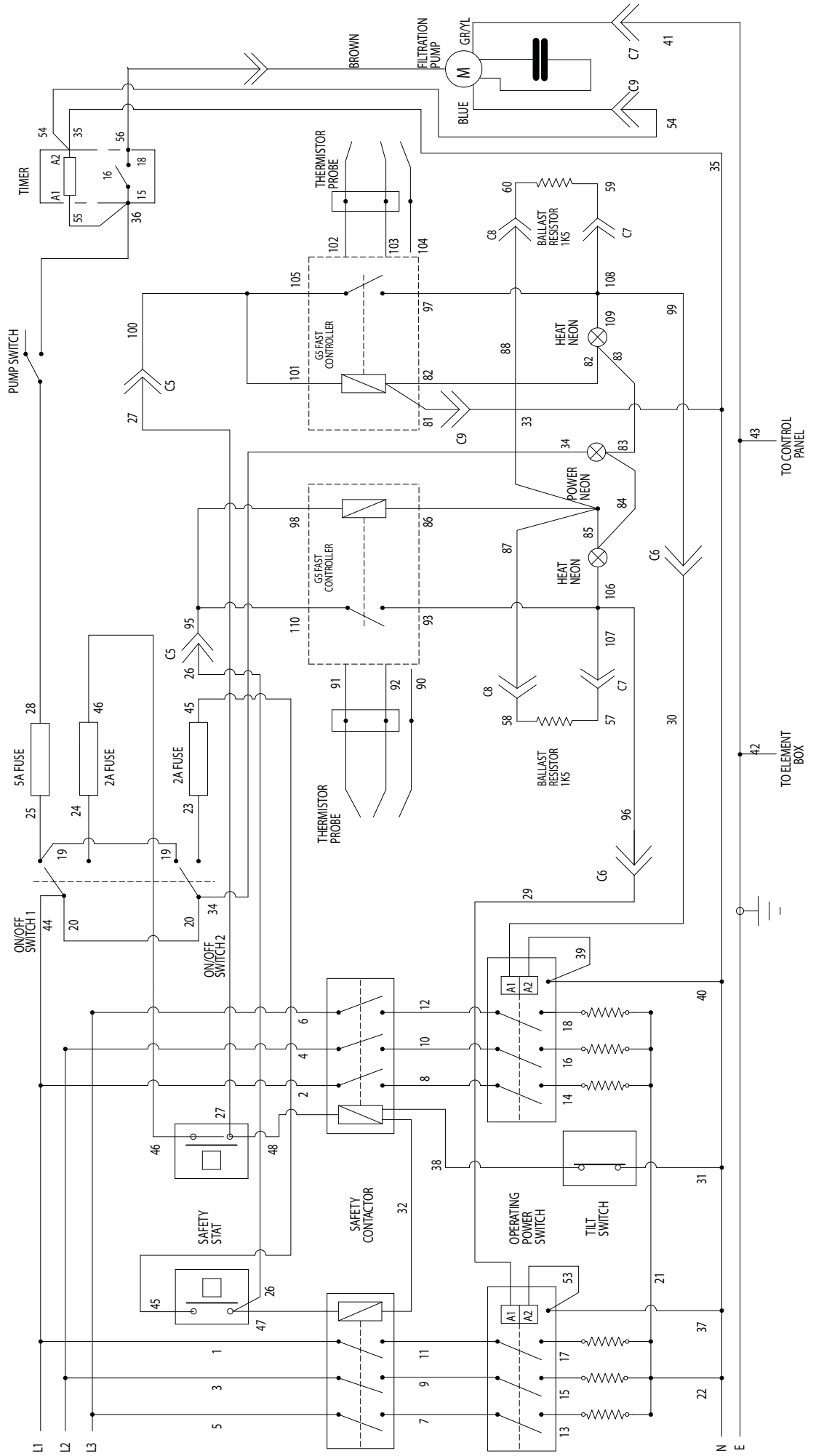

CIRCUIT DIAGRAM for E422

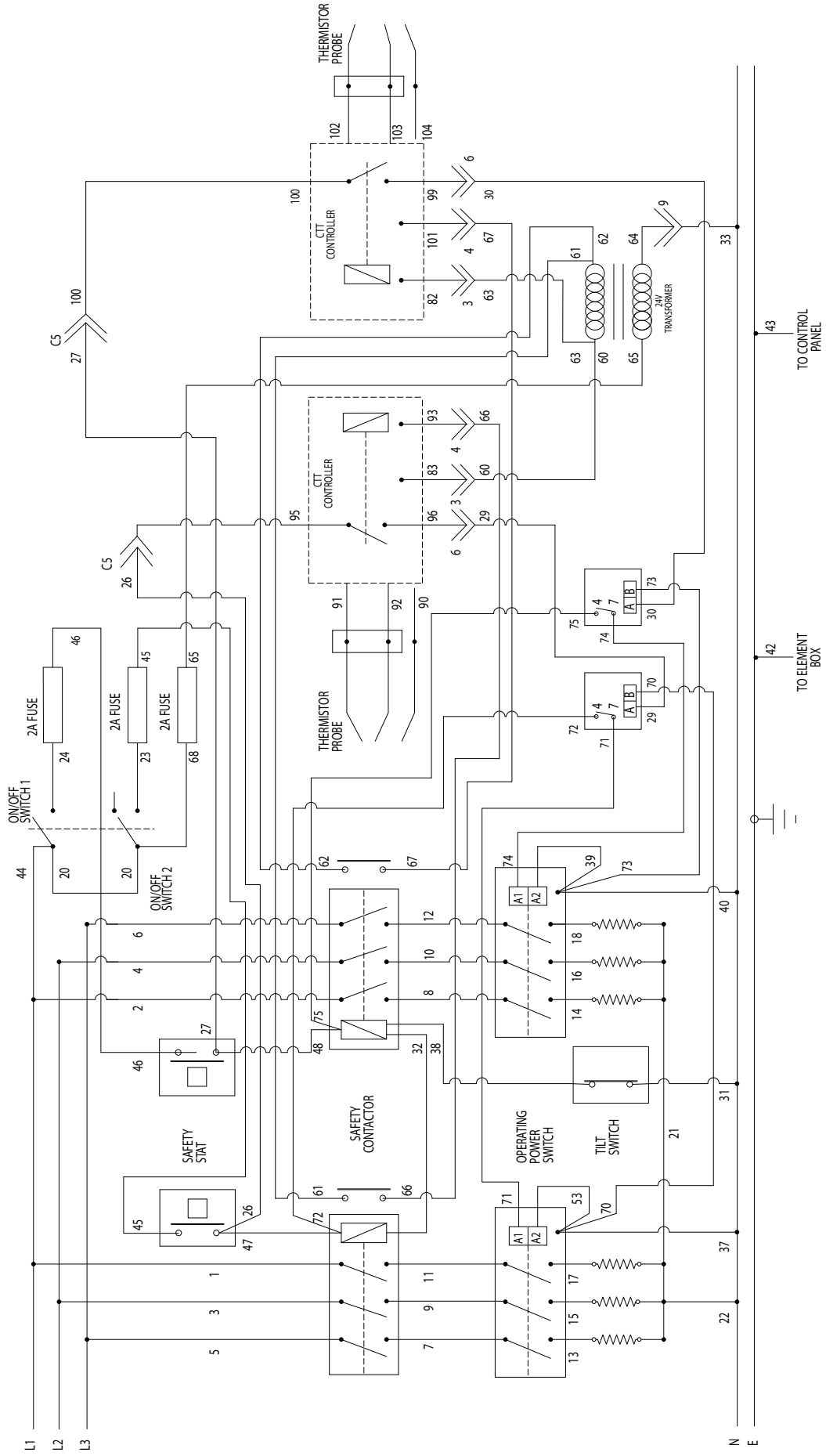

CIRCUIT DIAGRAM for E422F

