

3G Audio

KARAOKE AMPLIFIER

AK SERIES _____

AK-3120

AK-3200

AK-3300

OWNER'S MANUAL _____

CHINESE

PRECAUTIONS

- Thank you for purchasing our products. Please read this manual carefully for your correct operation of this equipment, and keep this manual for future reference.

- For your safety please don't open the rack to avoid electric shock due to high voltage inside. Consult professionals for maintenance help.
- Keep the instrument off rain or humidity.
- This instrument must work in places with good air flow.
- Please check whether local voltage supply can meet the requirement of this instrument.
- Please pull out the plug when this instrument is not in use for a long time.
- Load must be configured following this manual. Don't let the instrument work overloaded for a long time.

 Please make sure the local power supply is similar to what this appliance requires (~220V/50HZ),and carefully check there is no any damage for outlet and wire prior to operating the appliance.

CONTENT

	Power supply for this appliance	1
Introduction	Features	2
	Signal connector.....	2
	The front panel (AK3120)	3
	Operation (AK3120)	4
	The front panel (AK3200,AK3300).....	5
	Operation(AK3200,AK3300)	6
	The back panel	7
Controller (AK3200,AK3300)	8	
Installation	Prior to Installation	9
	System Connection	9
Attention	Safety Instruction	10
	Specification	11
	Maintenance	11

POWER SUPPLY

Please carefully check whether the local power supply meets what this appliance requires.

How to select the right power supply

You'd better carefully check whether the local power supply meets what this appliance requires prior to operating. You can adjust the switch on the back panel of this appliance to switch the power supply to 110V or 220V based on your local power supply. And you are advised that you must unplug before adjusting the switch for power supply selecting.

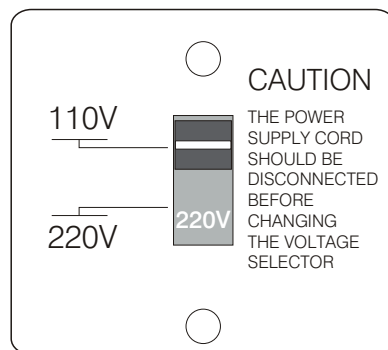

ACCESSORIES

Please make sure the following is attached prior to unpacking.

AK3120:

User Manual-----1 Piece

Warranty -----1 Piece

Certification -----1 Piece

AK3200/AK3300:

User Manual-----1 Piece

Warranty -----1 Piece

Certification -----1 Piece

Remote controller -----1 Piece

Battery -----2 Piece

INTRODUCTION

You'd better read the instructions prior to operating the appliance. And please keep it as a reference in the future.

FEATURES

- Refraining the whistle
- Automatic selection for signal sources
- Available for KTV Room
- Available for connecting 3 groups speaker simultaneously
- Built-in vocal embellishment circuit ,make the sound rich & natural
- Built-in strong refrigerant fan for ventilation to meet for a long period of time working.

SIGNAL CORD

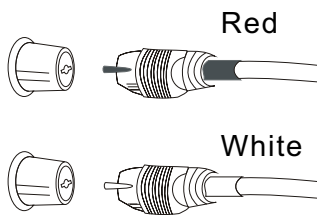

Male RCA connector (Red) to match Female RCA (Red)
Male RCA connector (White) to match Female RCA (White)

FUNCTION INSTRUCTIONS

FUNCTION INSTRUCTIONS (THE FRONT PANEL) ————— AK3120

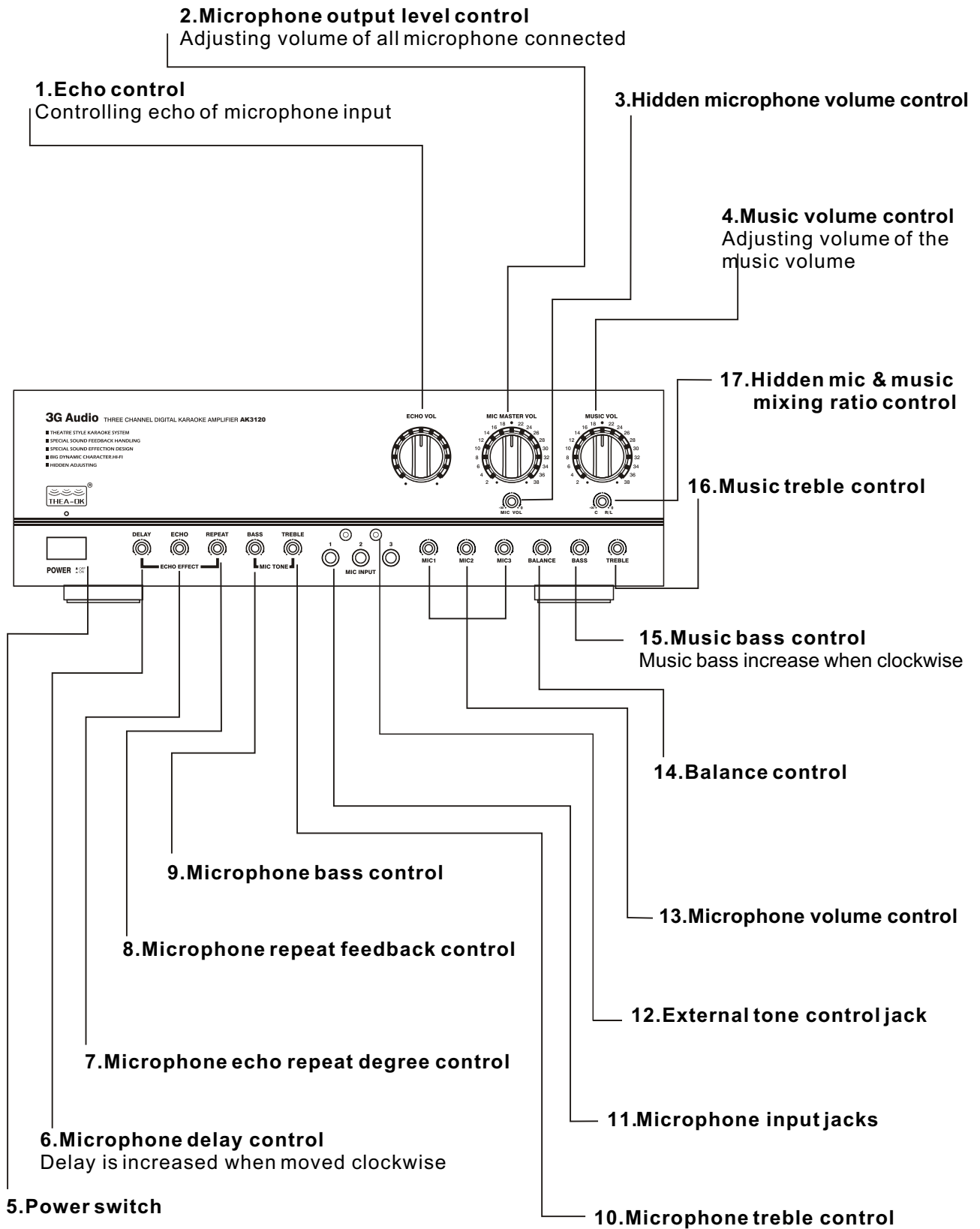

AK3120 OPERATION GUIDE

1. Push down power switch 5 to connect power supply

2. Insert microphone to microphone jack 11 and adjust the microphone volume, to get correct microphone volume by adjusting 13.

3. Adjusting vocal sound:

High frequency if you want to increase high frequency, please turn the high frequency control(TREBLE 10) by clockwise, and un-clockwise is reduce. No howling is suggested and preferred.

Low frequency if you want to increase low frequency, please turn the low frequency control(TREBLE 9) by clockwise, and anticlockwise is reduce. No howling is suggested and preferred.

4. Total microphone volume control:

Before the total microphone volume control 2 adjusting, please move this control between 1822, then you can operation on 2-3 step.

5. Add ECHO effect of microphone:

First turn the microphone volume control to middle position, then speaker to the microphone while you are adjusting the delay 6 and repeat control 7, and increase effect 8 until you get your ideal performance result

6. Adjusting music volume:

Make sure that the music volume should be at minimum position before power on, then increase step by step to get your ideal performance result.

7. Adjusting music sound quality:

Treble adjusting (TREBLE)

You can turn the TREBLE 16 by clockwise to increase treble high frequency, anticlockwise is for reducing treble

Bass adjusting (BASS)

You can increase the BASS 15 by clockwise to increase the low frequency, anticlockwise is for reducing bass.

8. Attention when using microphone:

When howling, please do not make the microphone and speaker not closed and near. Or you can low down microphone volume to cancel the howling. The microphone and mouth should keep certain distance and angle to ensure sound clear and pure.

The microphone switch should be power off when not using microphone, also please pull out the microphone from the microphone jack(s).

9. Microphone signal / left right channel signal ration adjusting

If you want the left and right channel should have microphone signal, please adjust 17 by clockwise, then the left and right channel signal will increase. Anticlockwise is for signal low down.

10. Howling Restraining:

A. To locate microphone volume control between 8-10 before inserting microphone

B. While adjusting microphone volume control, adjusting the music volume till you can get the balance between vocal singing and accompaniment music.

C. After above operation, if the microphone volume is not enough, then adjust each channel microphone volume hidden button.

FUNCTION INSTRUCTIONS

FUNCTION INSTRUCTIONS (FRONT PANEL) ————— AK3200/AK3300

Take AK3200 as a sample.

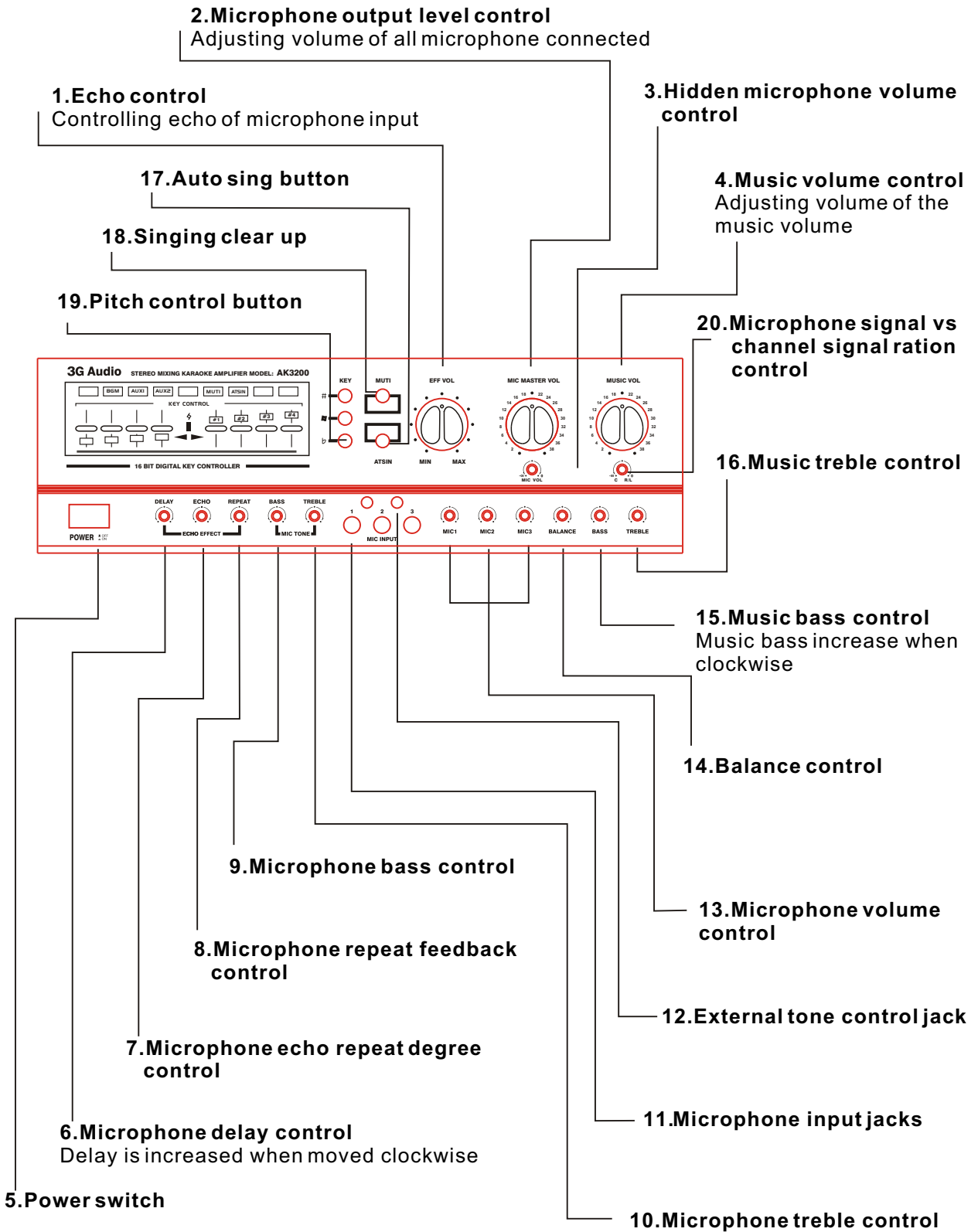

AK3200/AK3300 OPERATION GUIDE

1. Push down power switch 5 to connect power supply

2. Insert microphone to microphone jack 11 and adjust the microphone volume, to get correct microphone volume by adjusting 13.

3. Adjusting vocal sound:

High frequency if you want to increase high frequency, please turn the high frequency control(TREBLE 10) by clockwise, and un-clockwise is reduce. No howling is suggested and preferred.

Low frequency if you want to increase low frequency, please turn the low frequency control(TREBLE 9) by clockwise, and anticlockwise is reduce. No howling is suggested and preferred.

4. Total microphone volume control:

Before the total microphone volume control 2 adjusting, please move this control between 1822, then you can operation on 2-3 step.

5. Add ECHO effect of microphone:

First turn the microphone volume control to middle position, then speaker to the microphone while you are adjusting the delay 6 and repeat control 7, and increase effect 8 until you get your ideal performance result

6. Adjusting music volume:

Make sure that the music volume should be at minimum position before power on, then increase step by step to get your ideal performance result.

7. Adjusting music sound quality:

Treble adjusting (TREBLE)

You can turn the TREBLE 16 by clockwise to increase treble high frequency, anticlockwise is for reducing treble

Bass adjusting (BASS)

You can increase the BASS 15 by clockwise to increase the low frequency, anticlockwise is for reducing bass.

8. Tune function operation:

When your vocal singing tune is not accordant with the music, you can push the tune key 19, to make music tune is accordant with your vocal tune.

9. Microphone signal / left right channel signal ration adjusting

If you want the left and right channel should have microphone signal, please adjust 17 by clockwise, then the left and right channel signal will increase. Anticlockwise is for signal low down.

10. Attention when using microphone:

When howling, please do not make the microphone and speaker not closed and near. Or you can low down microphone volume to cancel the howling. The microphone and mouth should keep certain distance and angel to ensure sound clear and pure.

The microphone switch should be power off when not using microphone, also please pull out the microphone from the microphone jack(s).

11. Howling Restraining:

A. To locate microphone volume control between 8-10 before inserting microphone

B. While adjusting microphone volume control, adjusting the music volume till you can get the balance between vocal singing and accompaniment music.

C. After above operation, if the microphone volume is not enough, then adjust each channel microphone volume hidden button.

REAR PANEL

THE REAR PANEL CONFIGURATION AND THE FUNCTION

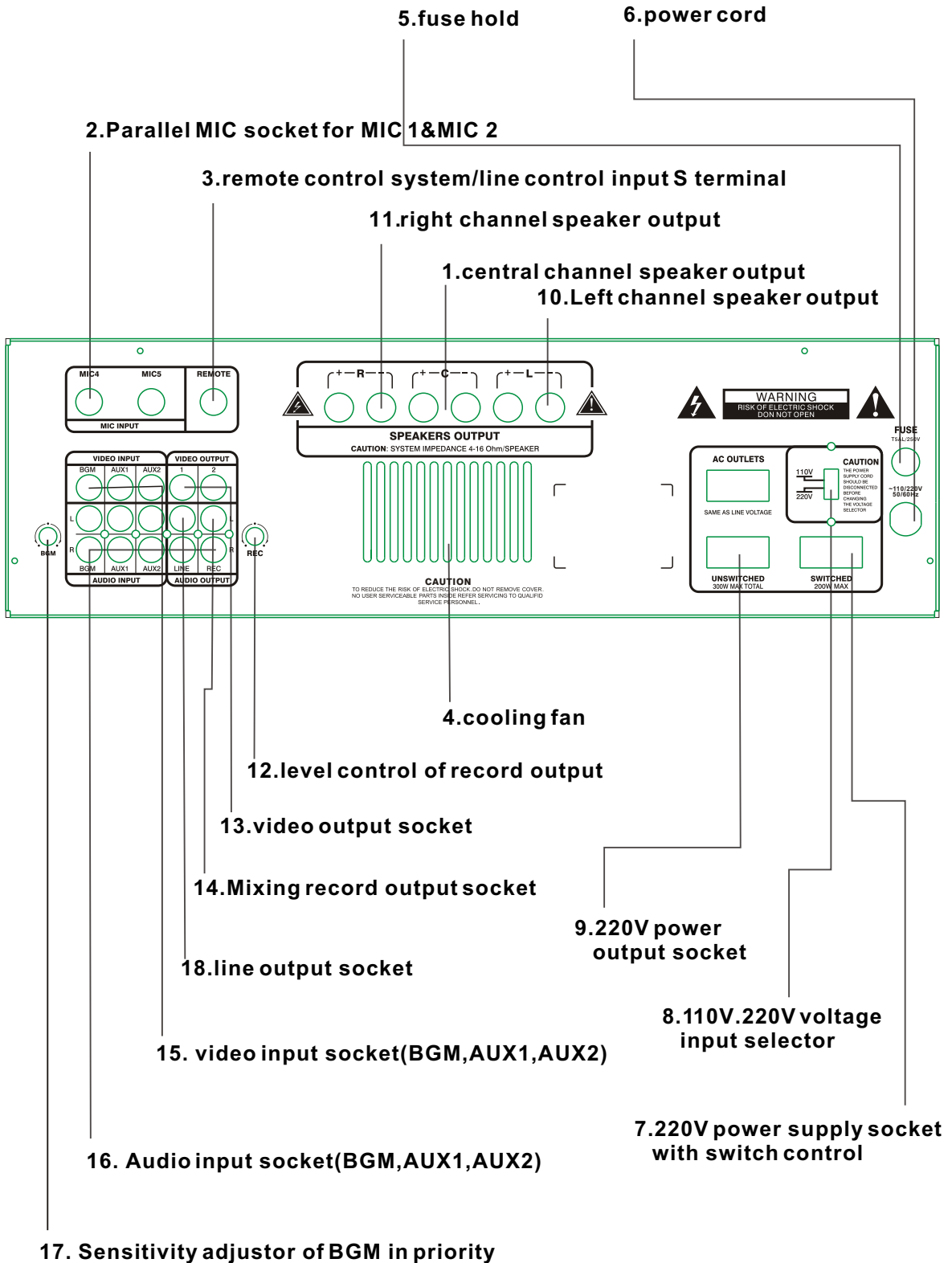

REMOTE CONTROLLER

REMOTE CONTROLLER ————— AK3200/AK3300

This unit can be controlled by the attached wireless remote controller, you can control the unit at your seat, it very convenient.

The name of button is same as the units', please refer to the introduction of units' to learn the function.

BATTERY INSTALLATION ————— AK3200/AK3300

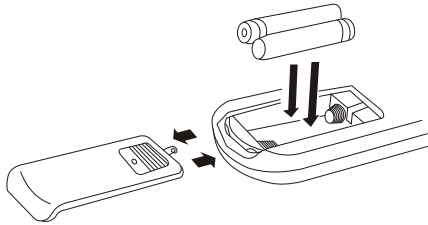

- 1.open the cover following the arrowhead
- 2.install the batteries(AA, R6,UM-3), following the diagram.
- 3.close the cover

THE NAME OF BUTTON AND FUNCTION ————— AK3200/AK3300

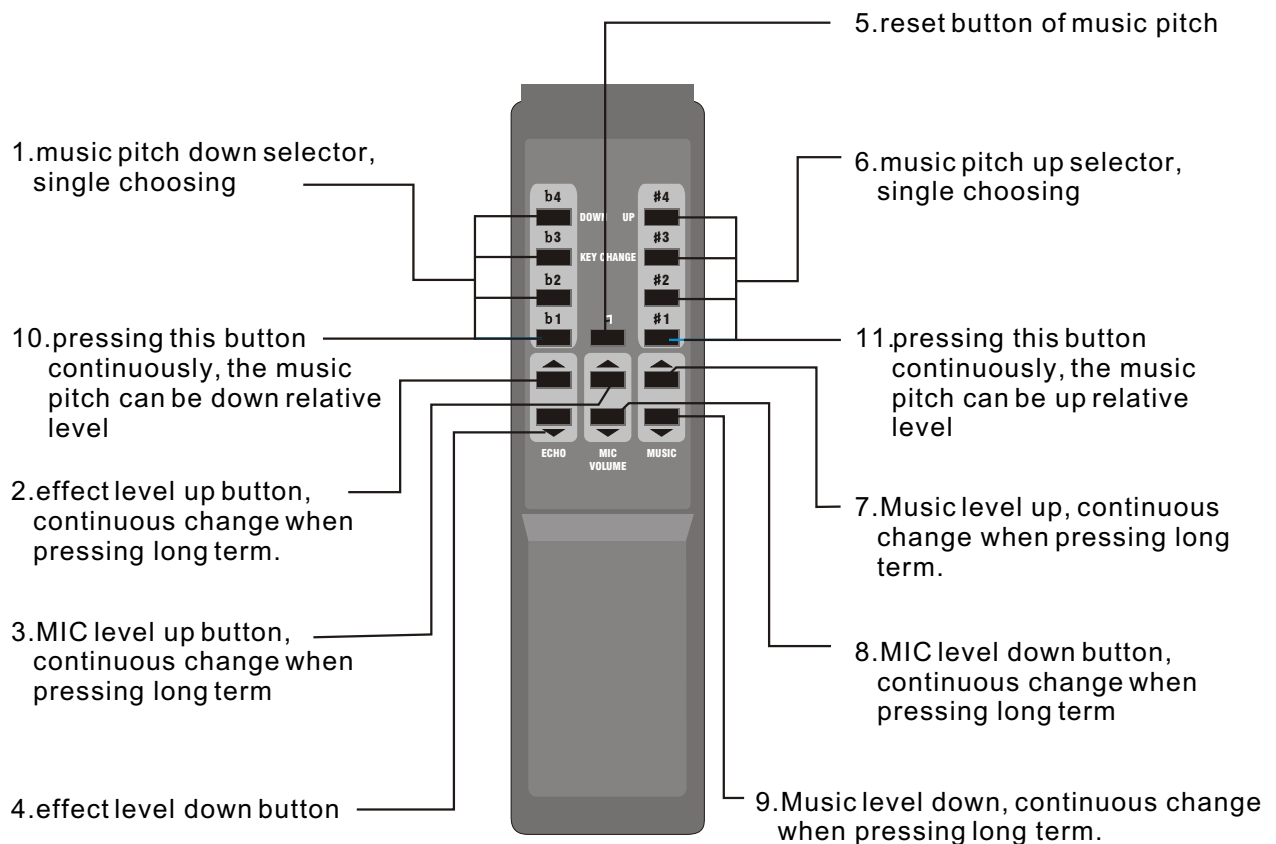

CONNECTION

CONNECTION OF THE SPEAKER CABLE

1. turn the screw of binding post anticlockwise, insert the cable into the hole;
2. turn the screw of binding post clockwise to make sure the cable impacted
choose appropriate speaker cable, connect the speaker under shortest way.

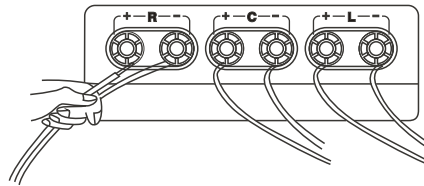

Please make sure the speaker phase correct. If the phase is inverted, the sound will be abnormal, and the LF will be not enough.

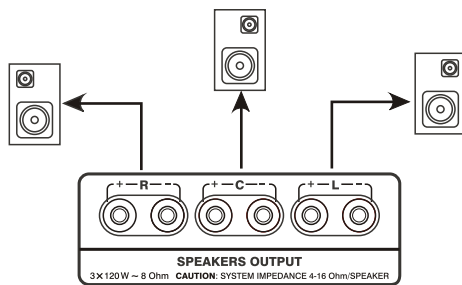

Note: the end of cable never touch another binding post

SYSTEM CONNECTION

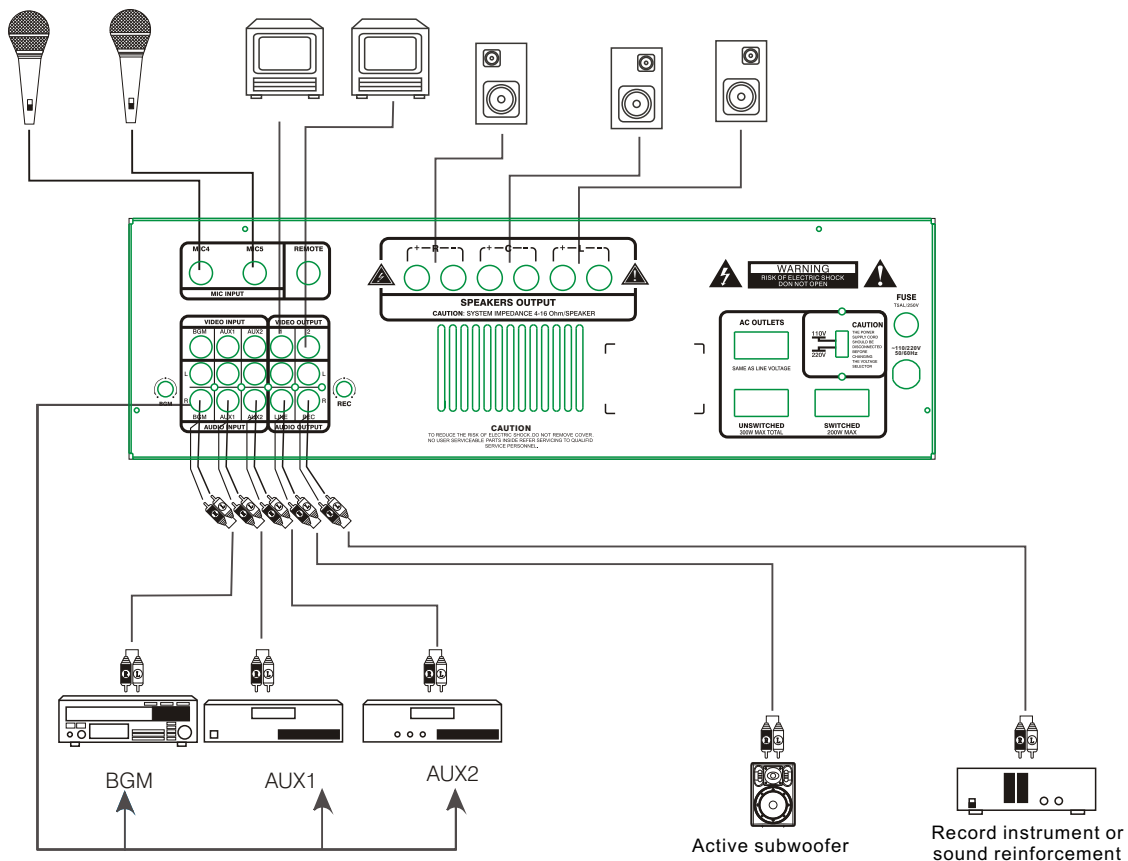

ADDITIONAL INSTRUCTION

SAFETY INSTRUCTIONS

DO NOT OPEN THE COVER:

Do not open the cover to avoid the risk of electric shock caused by high voltage parts in the product. Any problems caused by user's wrong actions are out of warranty.

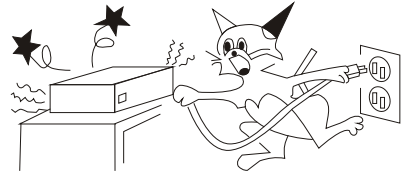

DO NOT DAMAGE THE POWER CORD:

Please hold the plug when pull out or plug in the cord. Do not pull out or touch the cord with wet hand, or it will cause the risk of electric shock. Power supply cords should be routed so they are not likely to be walked upon or pinched by items placed on or against them. When removing the cord from a power outlet be sure to remove it by holding the plug attachment and not by pulling on the cord.

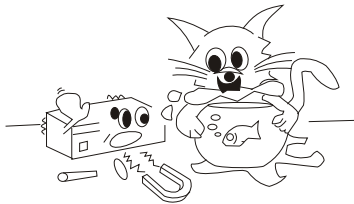

AVOID OBJECT AND LIQUID ENTRY:

Take care that objects do not fall into and that liquids are not spilled into the inside of the product. If the object or liquid enter the product, please ask qualified personnel to check it.

ABNORMAL STATUS:

In the event of abnormal noise and smell, please put off the power supply and pull out the cord, please ask qualified personnel to check it.

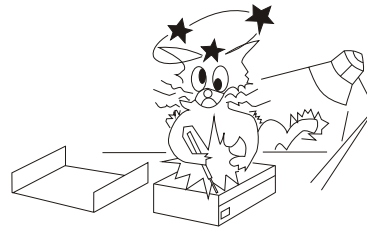

NONUSE FOR A LONG TIME:

When nonuse it for a long time, please put off the power supply and pull out the cord to avoid the unexpected dangers.

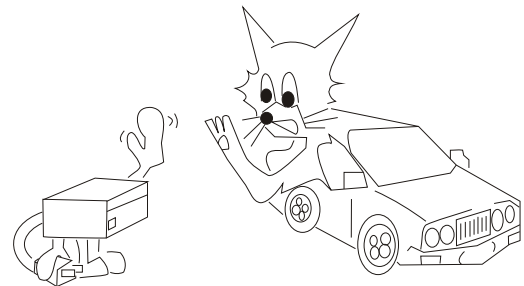

SPECIFICATION

SPECIFICATION

Output power(RMS)	Power supply..... ~110V/~220V,50Hz
AK3120 125W+125W+125W(1KHz,8Ohm)	
AK3200 200W+200W+200W(1KHz,8Ohm)	Power supply consumption
AK3300 300W+300W+300W(1KHz,8Ohm)	AK3120 <600W
THD (1KHz,100W,8Ohm)0.02%	AK3200 <1000W
Frequency response 20Hz-20KHz±2dB	AK3300 <1600W
Input sensitivity/impedance	AC output socket
MIC 20mV/2KOhm	One group with switch 200W
LINE 200mV/10KOhm	Two groups without switch 300W
VIDEO 1Vp-p/75Ohm	
Pitch control	Static power consumption 30W
Music	Net weight
LF(100Hz) ±10dB	AK3120 11.5kg
HF(10KHz) ±10dB	AK3200 12.5kg
MIC	AK3300 14.0kg
LF(100Hz) ±10dB	Total weight
HF(10KHz) ±10dB	AK3120 13.0kg
Effect ECHO	AK3200 14.0kg
Pitch change control ±4°	AK3300 15.5kg
(Except for AK3120)	
Loading impedance	Packing dimension 505x435x200(mm)
Output impedance 4-16Ohm	
Recommend impedance 8Ohm	

※Cosmetic changes may be made

MAINTENANCE

- ▲ The equipment can be cleaned with dry cotton cloth. If the equipment is abnormally dirty, please clean it with a piece of cotton cloth dipped in detergent for 5 to 6 seconds, and finally dry it with a piece of dry cloth.
- ▲ Don't use alcohol, insecticide, or any other volatile or corrosive liquid to clean the equipment, which will cause colour fade or flake-off of the equipment surface.
- ▲ When the equipment is not used for a long time, please keep it in an appropriate dry place.

3G Audio