

Pneumatic Positioner

YT-1200 Series

USER'S MANUAL

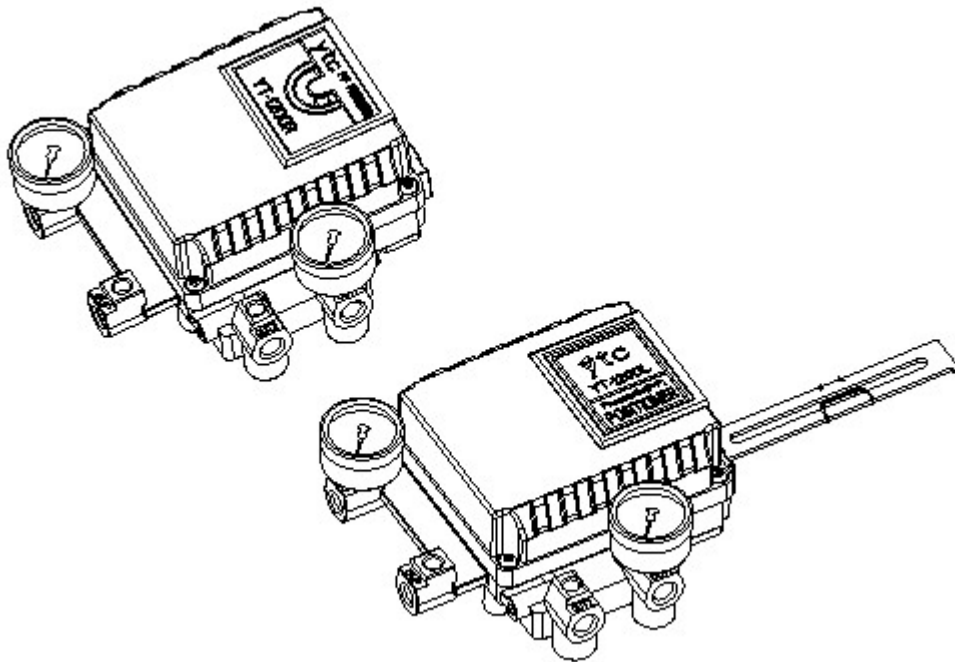

Introduction

Thank you for choosing YTC product. Each product is fully inspected after the production to offer you the highest quality. In order to fully utilize the product, we strongly recommend users to read this manual carefully and understood.

- The manual should be given to the end-user.
- The manual can be changed or revised without any prior notice. Any changes in product's specification, structure, and/or any components may not result immediate revised version of the manual.
- The manual should not be duplicated or reproduced for any purpose without any approvals from Young Tech Co., Ltd, South Korea / YTC.

Manufacturer Warranty

- For the safety, it is imperative to follow instructions in the manual. It is not manufacturer's liability for any damages which caused by users' negligence.
- It is not manufacturer's liability for any damages or accidents which resulted by any alteration or modification of the product and parts. If alteration or modification is necessary, please contact the manufacturer directly.
- Manufacturer warrants the product from the date of original retail purchase of the product for one (1) year, except as otherwise stated.
- Manufacturer warranty will not cover the products that the product have been subjected to abuse, accident, alteration, modification, tampering, negligence, misuse, faulty installation, lack of reasonable care, repair or service in any way that is not contemplated in the documentation for the product, or if the model or serial number has been altered, tampered with, defaced or removed; damages that occurs in shipment, due to act of God, failure due to power surge, and cosmetic damage. Improper or incorrectly performed maintenance or report voids this Limited Warranty.
- For detailed warranty information, please contact the corresponding local Young Tech Co., Ltd office or main office in South Korea.

Product Description

Main Features and Functions

- The product can operate normally in very extreme environment, such as vibration and temperature.
- The durability has been proven after testing 2 million cycles at the minimum.
- Response time is very short and accurate.
- Simple part change can set 1/2 Split Range.
- It is economical due to less air-consumption.
- Direct / Reverse action can be set easily.
- Zero & Span adjustment processes are simple.
- Feedback connection is easy.

Operation Logic

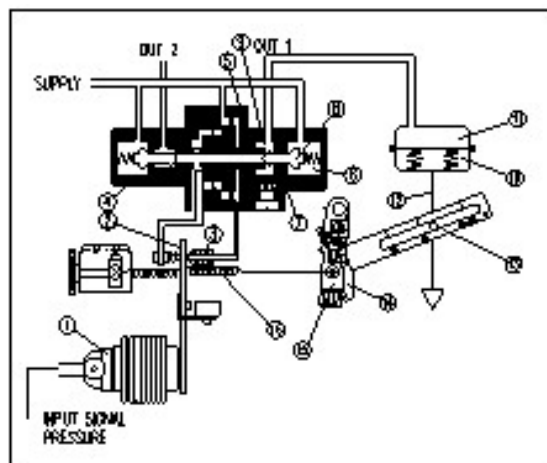

<YT-1200L>

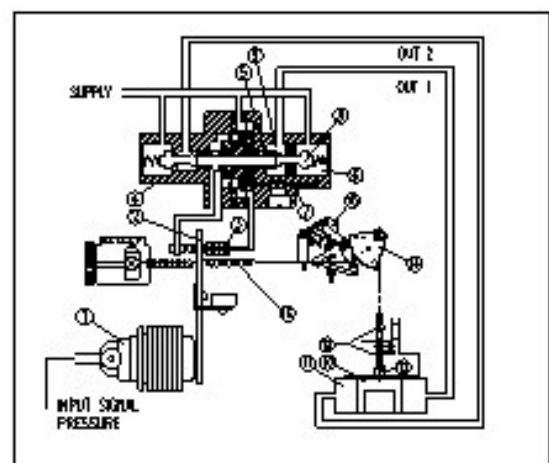

<YT-1200R>

Bellows(①) push flapper(②) if input pressure increases. Then the gap between nozzle(③) and flapper(②) increases, which results pressure in upper spool(⑤) exhaustion. This would cause spool(⑤) to rise upward. As the spool(⑤) rises, it pushes format(⑧), and the air pressure will be supplied to the actuator(⑩). As the actuator's inner pressure increases, the actuator stem(⑫) will move. For graphical diagram, please refer to <Figure 1>.

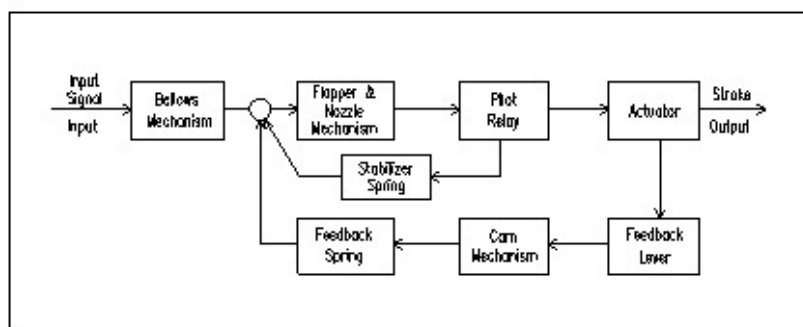

<Figure 1>

Label Description

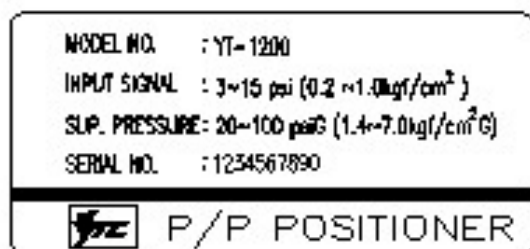

Model:	Indicates model name and any options (if any)
Input Signal:	Indicates current input signal range.
Supply Pressure:	Indicates the range of supply pressure.
Serial Number:	Indicates unique serial number.

Suffix Symbol

YT-1200 series follows suffix symbols as below.

YT-1200 **1** **2** **3** **4** **5**

1 Motion Type:	L : Linear R : Rotary
2 Acting Type:	S : Single D : Double
3 Feedback Lever (YT-1200L)	1 : 10 ~ 40mm 2 : 30 ~ 70mm 3 : 60 ~ 100mm 4 : 100 ~ 150mm
Feedback Lever (YT-1200R)	1 : M6 x 40L 2 : M6 X 63L 3 : M8 X 40L 4 : M8 X 63L 5 : NAMUR
4 Connection Type	1 : PT 2 : NPT
5 Ambient Temp.	S : -20°C ~ 70°C H : -20°C ~ 120°C L : -40°C ~ 70°C

* For special specification, please contact our sales department.

Specification

Category	YT-1200L		YT-1200R	
	Single	Double	Single	Double
Input Signal	0.2~1.0kgf/cm ² (3~15psi)			
Supply Pressure	1.4~7.0kgf/cm ² (20~100psi)			
Stroke	10 ~ 150mm		0~90°	
Air Connection	PT (NPT) 1/4			
Gauge Connection	PT (NPT) 1/8			
Protection	IP66			
Cam	Linear			
Ambient Temp	Standard: -20~70°C High: -20~120°C Low: -40~70°C			
Linearity	±1.0% F.S		±2.0% F.S	
Hysteresis	±0.75% F.S		±1.0% F.S	
Sensitivity	±0.2% F.S		±0.5% F.S	
Repeatability	±0.3% F.S		±0.5% F.S	
Air Consumption	3.0LPM(Sup=1.4kgf/cm ²), 11LPM(Sup=4.0kgf/cm ²)			
Flow Capacity	80LPM(Sup=1.4kgf/cm ²), 200LPM(Sup=4.0kgf/cm ²)			
Material	Aluminum Diecasting			
Weight	1.7kg			

* Test under ambient temperature of 20°C, absolute pressure of 760mmHg, and humidity of 65%. Please contact us for the more detailed specification.

Parts and Assembly

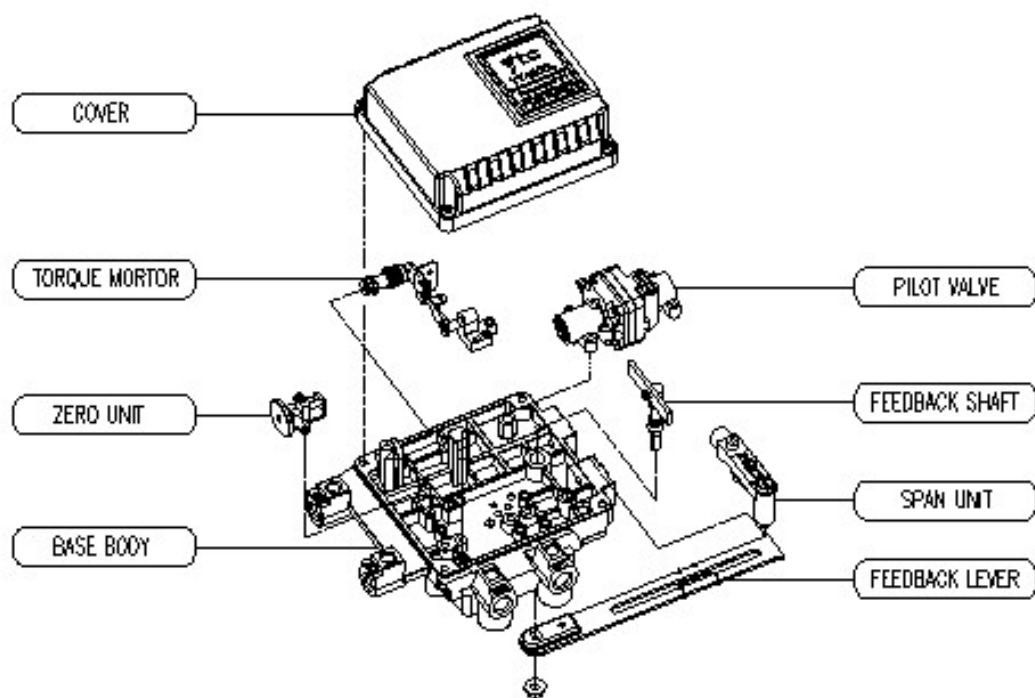

<YT-1200L>

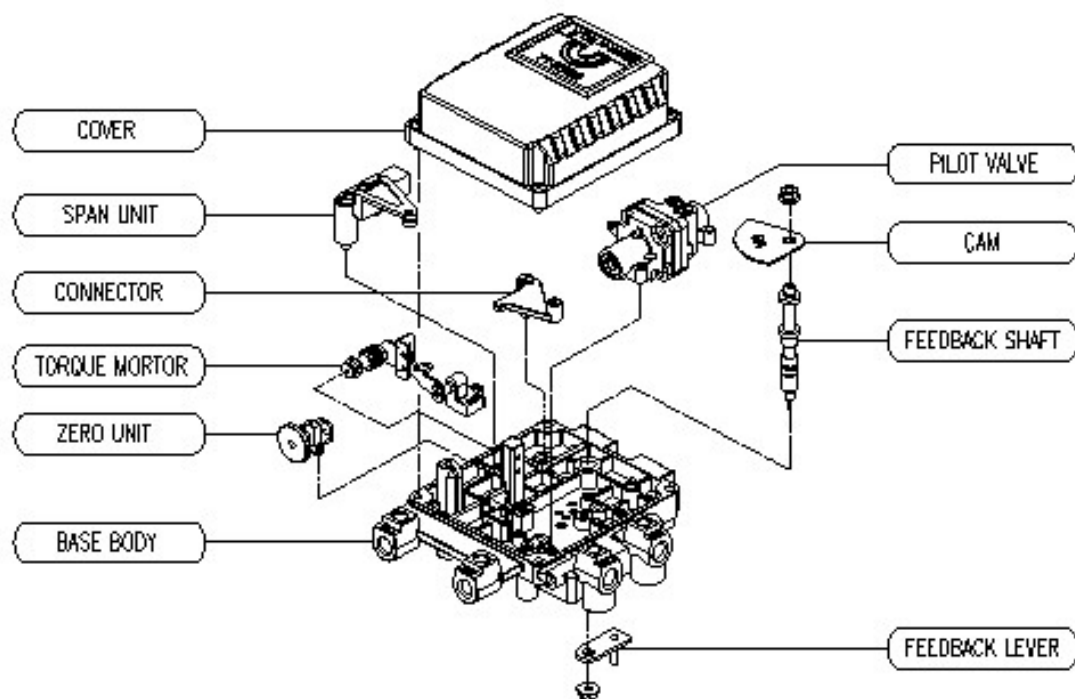

<YT-1200R>

Dimensions

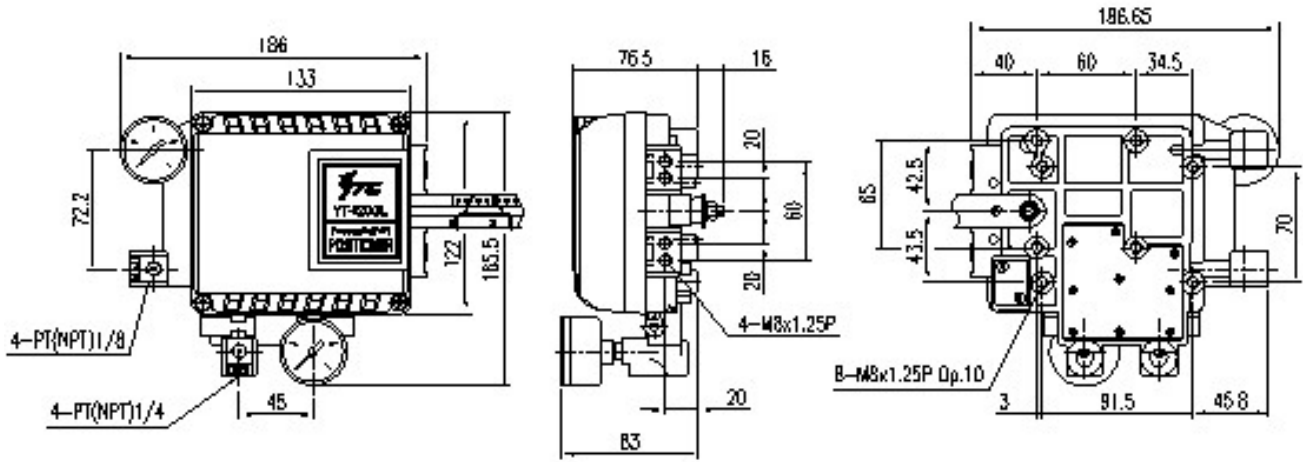

<YT-1200L Dimension>

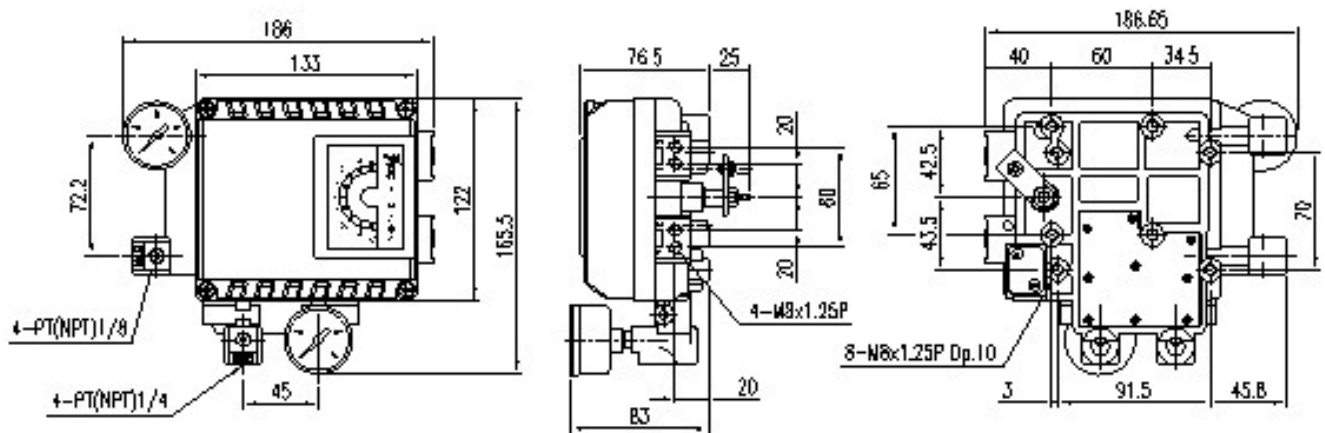

<http://www.ytc.kr>

<YT-1200R Dimension>

Installation

Safety Warning

When installing a positioned, please ensure to read and follow safety instruction.

- All input and supply pressure to valve, actuator, and other related devices must be turned off.
- Use bypass valve or other equipment to avoid entire system "shut down."
- Make sure there is no remaining pressure in the actuator.

Tools for Installation

- ① Hexagonal wrench
- ② Screw Drivers (+) and (-)
- ③ Spanners for hexagonal-head bolts

YT-1200 Installation

YT-1200L should be installed on linear motion valve such as globe valve or gate valve using spring return type diaphragm or piston actuator. Before installation, be sure to check for following installation components.

- ① YT-1200L main body
- ② Feedback lever and lever spring
- ③ Flange nut (bottom side of YT-1200L)
- ④ 4 pcs of hexagon head bolts (M8 x 1.25P)
- ⑤ 4 pcs of M8 plate washer

Installation Steps

1. Proper bracket must be made in order to attach positioned on the actuator yoke. Please consider following when making a bracket.
 - A. Feedback lever should be leveled at 50% of the valve stroke. (refer to step G)
 - B. Feedback lever connection bar of the actuator damp should be installed at the positioned that the valve stroke and numbers which indicated on the feedback lever must be fitted. (refer to step H)
2. Attached YT-1200L to the bracket, which was produced in previous step, by using bolts. <Fig 1> Please refer to backside of the unit for size of the bolts. The standard size of bolt is M8 x 1.25P and other bolts sizes are available. Please contact YTC sales department.
3. Attach YT-1200L (with bracket) to the actuator yoke – DO

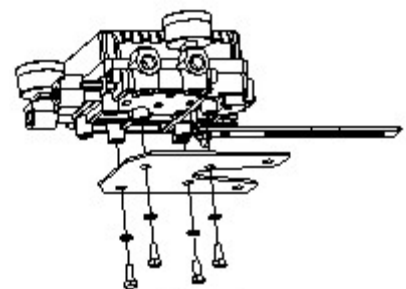

<Figure 1>

NOT TIGHTEN COMPLETELY.

4. Connect YT-1200L feedback lever to the actuator clamp. The gap on the YT-1200L feedback lever is 65mm. The connection bar thickness should be less than 6.3mm.
<Fig 2>

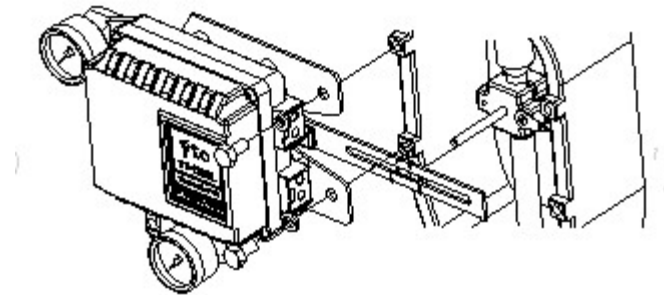

<Figure 2>

5. Connect air filter regulator to the actuator temporarily. Set supply pressure of the regulator in order to position the actuator damp at 50% of valve stroke. <Fig 3>

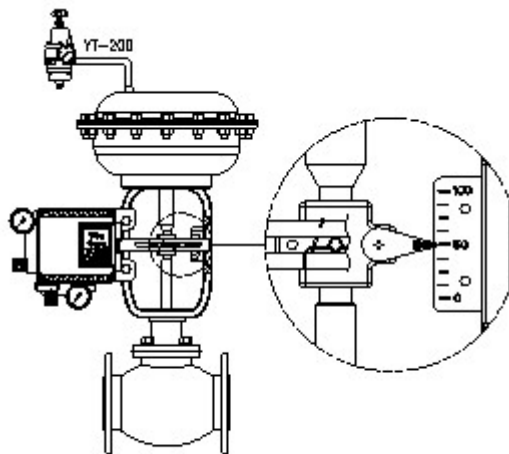

<Figure 3>

6. Insert connection bar into the YT-1200L feedback lever. The connection bar should be inserted at the 50% point on the feedback lever, which would help to reduce hysteresis.
<fig 4>

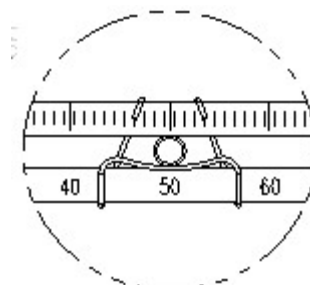

<Figure 4>

7. If connection bar does not point at 50% point, then adjust bracket or feedback link bar position. Failure to position at 50% would lower the linearity of the positioner. <fig 5>

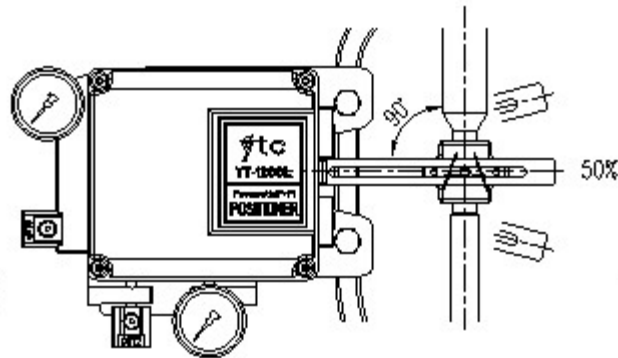

<Figure 5>

8. Check valve stroke. The stroke numbers are indicated on the feedback lever. Position connection bar at the number on the feedback lever according to the valve stroke. <fig 6> To adjust, move the bracket or the connection bar.

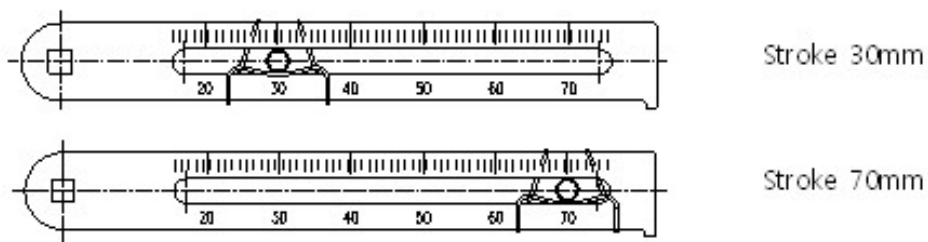

<Figure 6>

NOTE

After installing YT-1200L, operate the valve from 0% to 100% stroke by using air filter regulator. Both of 0% and 100%, the feedback lever should not touch the lever stopper, which is located on the backside of YT-1200L. <fig 7> If the feedback lever touches the stopper, YT-1200L should be installed further away from the center of the yoke.

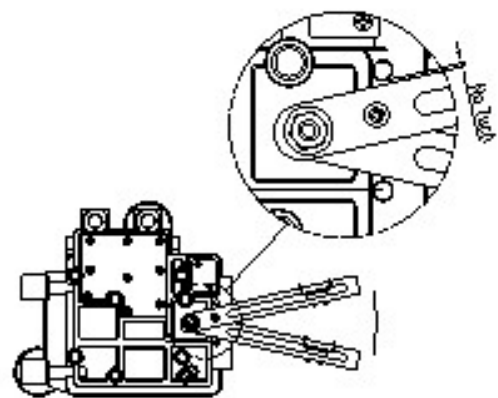

<Figure 7>

9. After the proper installation, tighten all of the bolts on the bracket, the feedback lever, and the connection bar.

YT-1200R Installation

YT-1200R should be used for rotary motion valve, that is ball valve, butterfly valve using rack and pinion, scotch yoke or complex type actuator, which its stem rotates 90 degrees. Before installation, be sure to check for following installation components.

- ① YT-1200R main body
- ② Fork lever and lever spring
- ③ 1 set of bracket (3 pcs)
- ④ 4 pcs of hexagon head bolt M8 x 1.25P
- ⑤ 4 pcs of M8 plate washer

YT-1200R Install Example

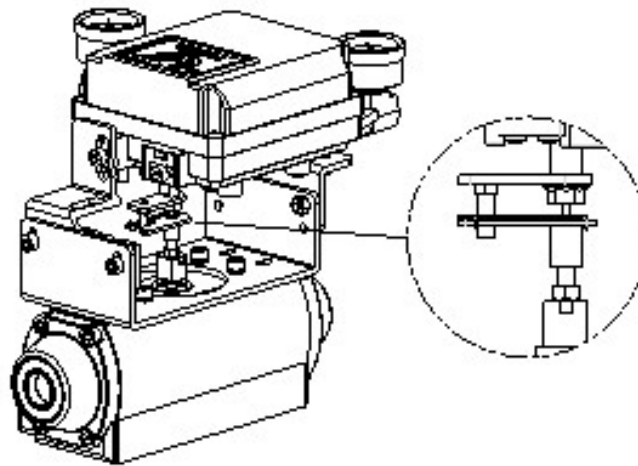

YT-1200R on Fork Lever

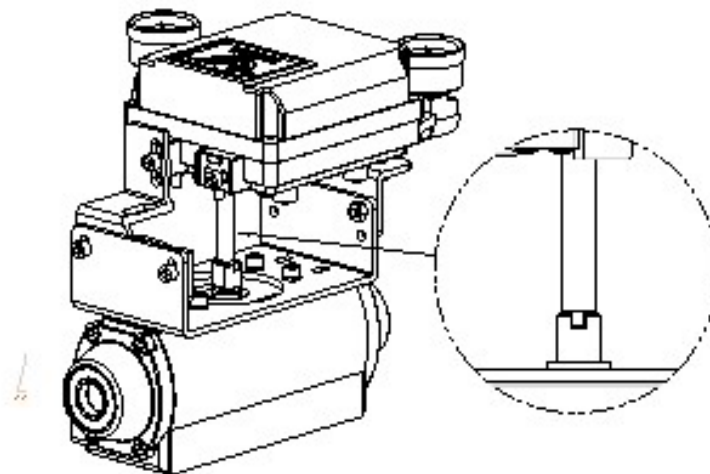

YT-1200R on NAMUR Lever

Bracket Information

YT-1200R is supplied with standard bracket. The bracket can be used for fork lever and NAMUR bracket. Please see <fig 8> for more detailed information.

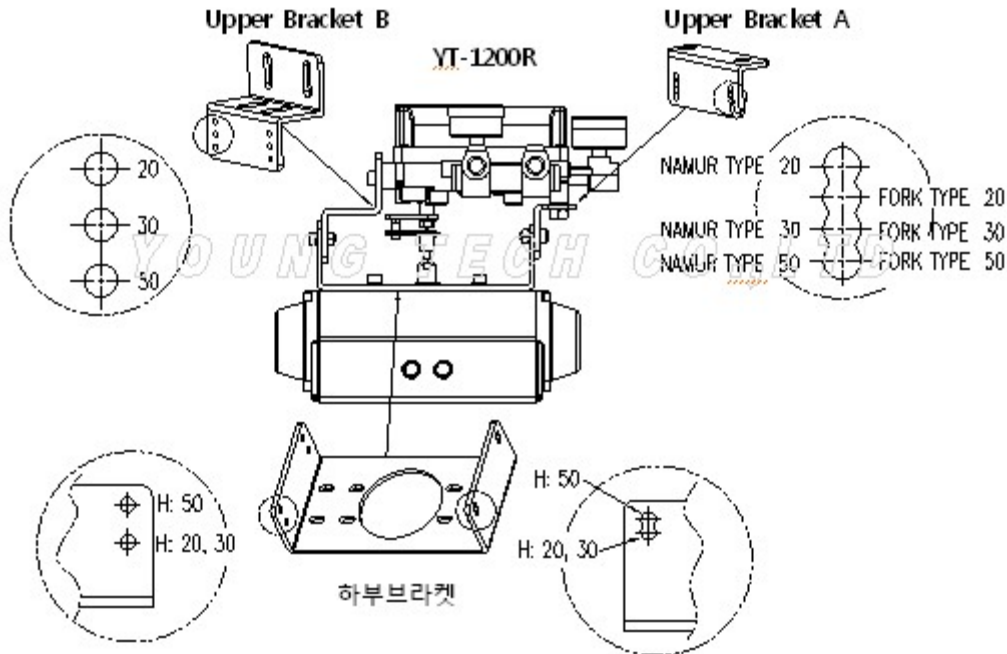

<Figure 8>

1. Standard actuator stem height (H) is 20, 30, or 50 mm. After check "H", assemble with the bracket as shown in <fig 8 & 9>

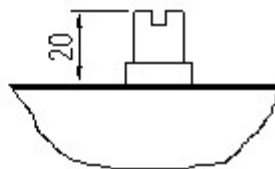

Actuator Stem (H)

Actuator

<Figure 9>

2. Attached bracketed YT-1200R to the actuator by using hexagonal-headed and wrench bolts. Size of the bracket hole is 6mm. When tightening bolts, use spring washer or similar for complete attachment to the actuator, so YT-1200R will not be shaken by vibration or any other impact. The direction of bracket is different by the operating condition, but in general, the positioned is installed as shown. <fig 10>

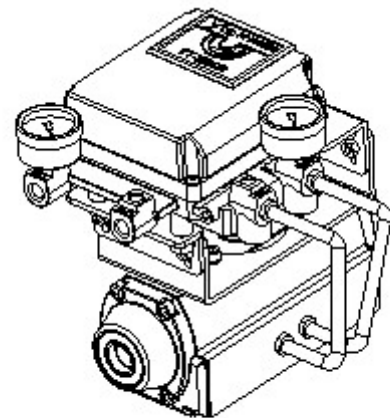

<Figure 10>

3. Set rotation position of the actuator stem at zero point, "0%". For a single type of actuator, it is easy to check zero point, because the actuator stem is positioned at zero point when there is no supply pressure. If double acting actuator is used, check actuator stem's rotation direction (clockwise or counter-clockwise) by supplying pressure.
4. Install the fork lever as shown in <fig11> after setting actuator stem at zero point. Check the direction of the actuator stem – clockwise or counter-clockwise. Installation angle of the fork lever should be 45 degrees based on the linear shaft. For NAMUR shaft, the angle does not matter.

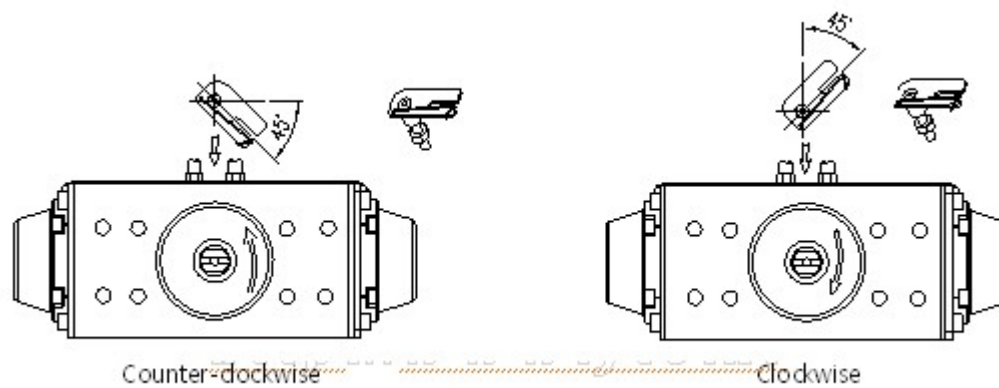

<Figure 11>

5. After setting fork lever position, lock nuts which are assembled on bottom of the fork lever.
6. Attach YT-1200R to the bracket. Fix the damping pin on the main shaft of YT-1200R and insert connection bar into the fork lever slot, so it can be locked to the fork lever spring. This sets the alignment of the main shaft of YT-1200R and center of the actuator stem. Bad alignment of the main shaft and the actuator stem lowers YT-1200R's durability, because too much force will be on the main shaft of YT-1200R. <fig 12>

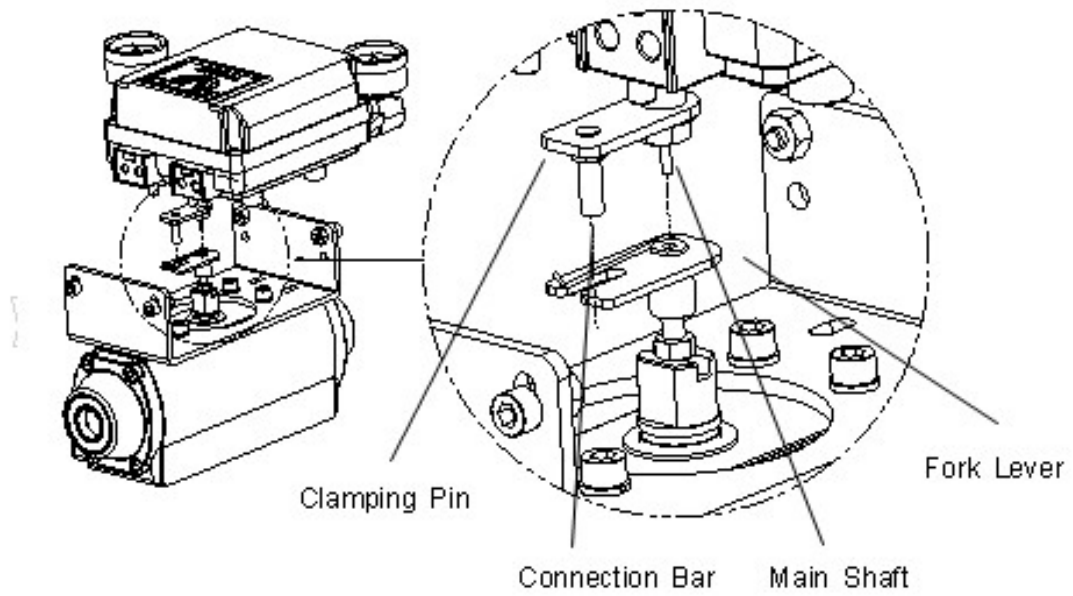

<Figure 12>

7. Tighten YT-1200R base and the bracket with hexagon-headed bolts and plate washer. It is recommended to tighten four bolts after checking YT-1200R's position. <fig 13>

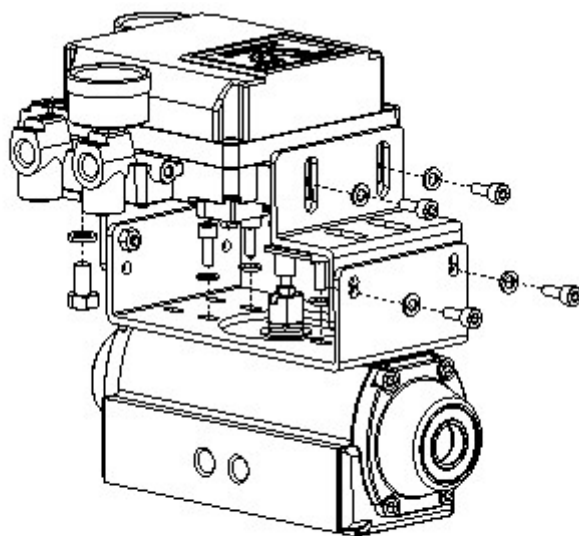

<Figure 13>

Piping Connection

Note

- To avoid entering moisture, oil, or dust into the product, please carefully make selection of supply pressure compressor.
- It is recommended to attach air filter regulator <YT-200> before supply port of YT-1200.

Supply Pressure Condition

- ① Dry air with at least 10°C lower than ambient temperature.
- ② Avoid from dusty air. Filter can only sort 5 micron or larger.
- ③ Avoid any oil.
- ④ Comply with ANSI/ ISA-573 1975(R1981) and ISA S73-1975(R1981).
- ⑤ Not to be used beyond the range of 1.4 – 7 kgf/cm² (140 – 700 kPA).
- ⑥ Set air filter regulator's supplied pressure 10% higher than actuator's spring range pressure.

Pipe Condition

- ① Make sure inside of pipeline is emptied.
- ② Do not use pipeline that has been squeezed or has hole.
- ③ To maintain flow rate, use the pipeline that has more than 6mm inner diameter. (10mm outer diameter)
- ④ Do not use extremely long pipeline system. It may affect flow rate due to the friction inside of the pipeline.

Piping connection with actuator

- Single Acting Actuator

YT-1200 series single acting type is set to use OUT1 port. OUT1 port should be connected with supply pressure port from actuator when using single acting type of spring return actuator. <fig 14 & 15>

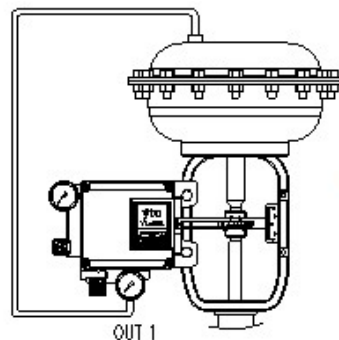

<Figure 14: YT-1200L>

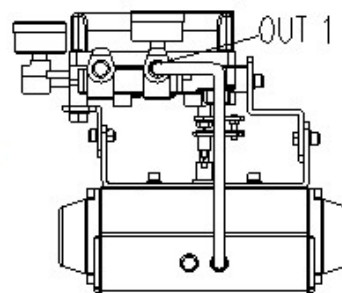

<Figure 15: YT-1200R>

- Double Acting Actuator

For YT-1200 series double acting type, when inputting current signal, supply pressure is out from OUT1 port. Please refer to <fig 16 & 17>

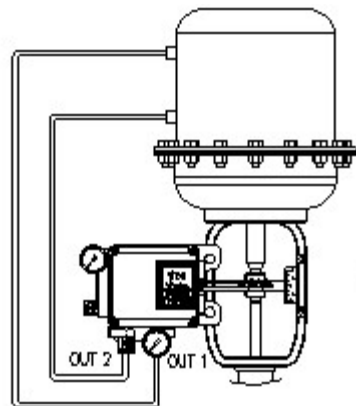

<Figure 16: YT-1200L>

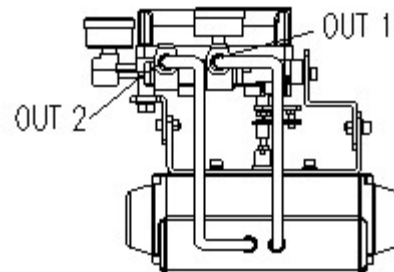

<Figure 17: YT-1200R>

Adjustment

Adjustment – Cam

- ① Direction of actuator's stem rotation must be checked when supply signal is supplied. When actuator's stem rotates clockwise, the face of cam must be shown "DA." On the other hand, when the stem rotates counter-clockwise, adjust cam so "RA" shows on the face of cam.
- ② Check whether actuator's angle is at the initial point.
- ③ After checking the initial point, release the hexagonal flange nut and adjust the position of the bearing so it is at 0 point. <Figure 18>
- ④ When produced, the cam is set as RA.

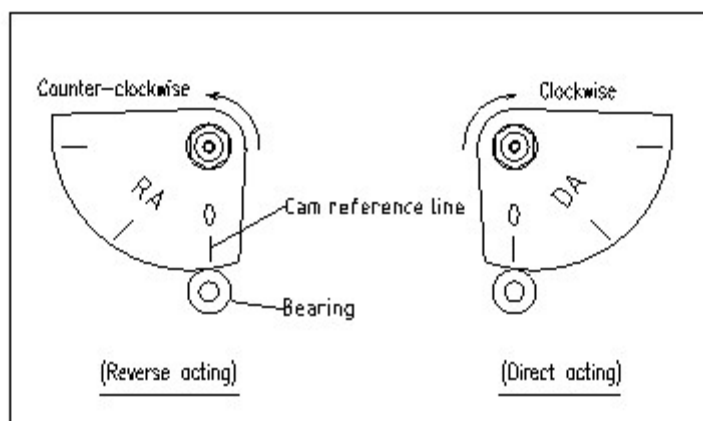

<Figure 18>

Adjustment – Zero Point

- ① Set supply signal at 3 psi and rotate adjuster clockwise or counter-clockwise to adjust actuator's rotation angle. <Figure 19>
- ② When adjusting zero for single actuator, rotation angle is equal to positioner's pressure gauge.

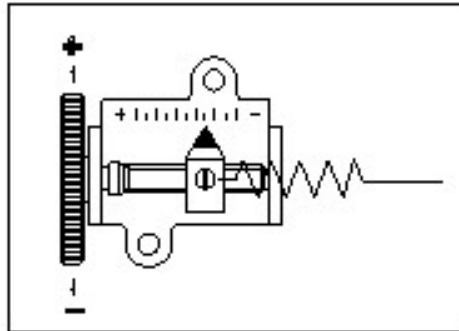

<Figure 19>

Adjustment – Span

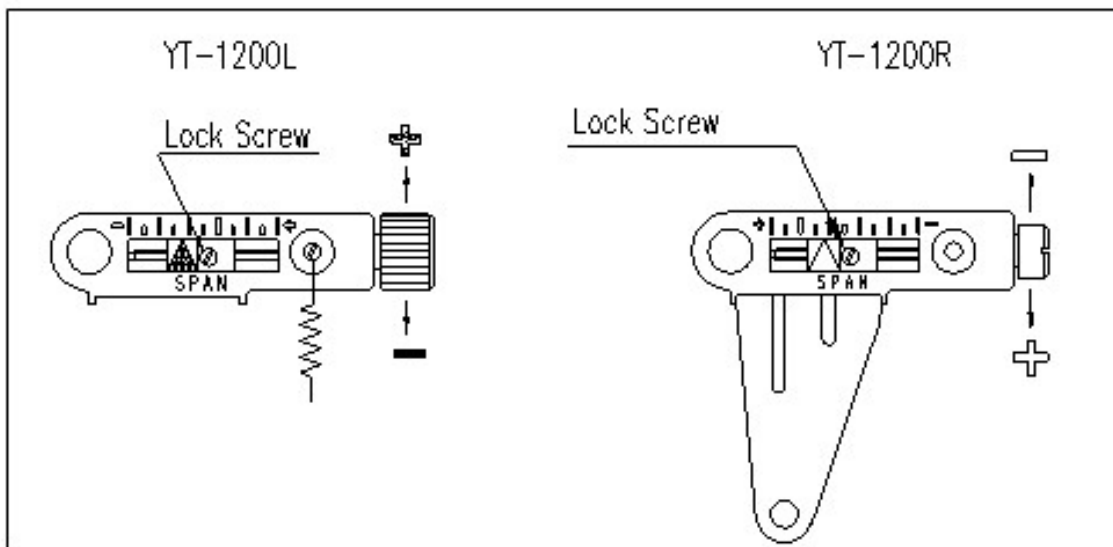

<Figure 20>

- ① After setting zero, rotate Span screw so supply signal reaches at the span point on the indicator.
- ② Changing span point affects zero point setting. So zero setting must be set again. After setting zero point, confirm the span point. This step must be repeated until both points are properly set.
- ③ If 1/2 split range is used, YT-1200L can be used after span and zero point are set. For YT-1200R with 1/2 split range, the span spring must be changed.
- ④ After setting is completed, tighten Lock Screw. <Figure 20>

Adjustment – A / M Switch <Auto / Manual>

1. A / M switch adjusts the valve operation to automatic or manual.
2. YT-1200 series is set as "A" / Automatic as default. If user wants to set as "M" / Manual, the setting can be adjusted by turning the switch counter-clockwise.

<fig 21>

3. If the setting is at "M", the air pressure will be supplied to the actuator directly. Always set the setting back to "A" after any change.
4. If OUT2 in single acting actuator or double acting actuator is used, A / M switch will not operate.

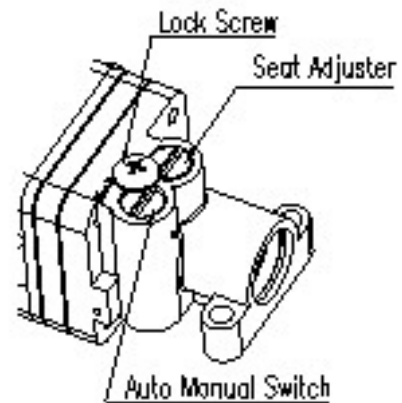

<Figure 21>

Adjustment – Seat Adjuster

- ① Seat adjuster is set according to the customer's request before the positioner is delivered. Please do not adjust the seat adjuster.
- ② Seat adjuster is used for double acting actuator. Please do not touch the seat adjuster, because it can affect the positioner's performance.

Troubleshooting

➤ **Positioner does not respond to the input signal.**

- ① Check supply pressure level. The level must be at least 1.4 kgf/cm²
- ② Check if input signal is properly supplied to the positioned. The signal should be 3-15 psi.
- ③ Check if the positioner's nozzle has been blocked. Also, check if the pressure is supplied to the positioned and the pressure is being exhausted through the nozzle. If the nozzle has been blocked by any substances, please send the unit to YTC for repair.
- ④ Check if feedback lever has been installed properly.

➤ **The pressure of OUT1 reaches exhausting pressure level and does not come back down.**

- ① Check A / M switch. If the switch has been damaged, replace the switch or pilot relay valve.
- ② Check for a gap or damages between the nozzle and the flapper. If damaged, please send the unit to YTC for repair.

➤ **The pressure is exhausted only by A / M switch.**

- ① Check if the positioner's nozzle has been blocked. Also, check if the pressure is supplied to the positioner and the pressure is being exhausted through the nozzle. If the nozzle has been blocked by any substances, please send the unit to YTC for repair.

➤ **Hunting occurs.**

- ① Check if safety spring has been displaced. <Next to pilot relay valve>
- ② Check if the size of actuator is too small. If so, insert an orifice in order to reduce the pressure flow rate.
- ③ Check if there is any friction between the valve and the actuator. If so, increase actuator's size or reduce the friction level.

➤ **Actuator only operates by on / off.**

- ① Check pipe connection
- ② Check cam direction

➤ **Linearity is too low.**

- ① Check if the feedback lever is properly installed. Especially check if the feedback lever is parallel to the around at 50% point.
- ② Check if zero and span has been properly adjusted, that is not too low or not too

high.

- ③ Check if supply air pressure level is stable from the regulator. If the level is unstable, replace the regulator.

➤ **Hysteresis is too low.**

- ① In case of double acting actuator, check if seat adjustment has been properly done. Please contact YTC for any further inquiries regarding the seat adjustment.
- ② Backlash can occur when feedback lever and lever spring is loosen. To avoid backlash, adjust the lever spring.
- ③ Check if the connection bar to the feedback lever is tightly fastened.

Young Tech Co., Ltd

Address: #662-8 Pungmu-Dong, Gimpo-City, Kyunggi-Do, South Korea
Telephone: +82-31-986-8545
Fax: +82-31-986-2683
Website: <http://www.ytc.kr>

User Manual and other information on the documents are subjected to change without any notice. Please visit website for most updated information, Printed Date: June, 2007