

Elite Steam
Residential Steam Humidifiers



User manual

Revision 3.0

→ READ AND SAVE THESE INSTRUCTIONS ←

Warning

If present, remove the following items:

LATCH THE CYLINDER CLAMP

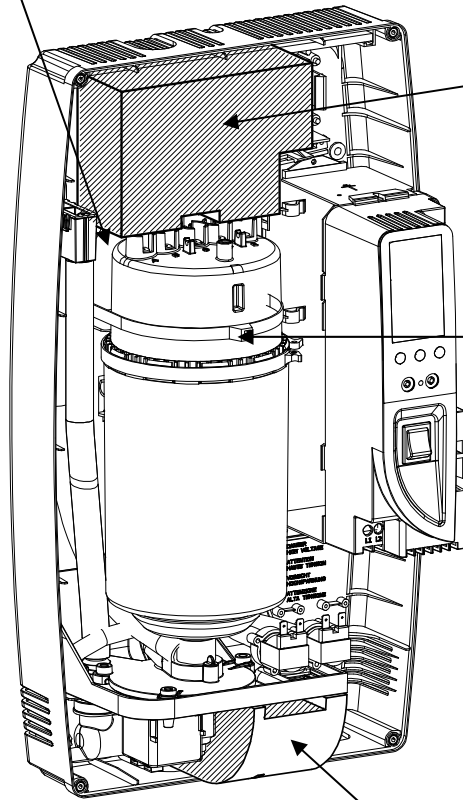

REMOVE BEFORE INSTALLING

REMOVE BEFORE INSTALLING

REMOVE BEFORE INSTALLING

REMOVE BEFORE INSTALLING

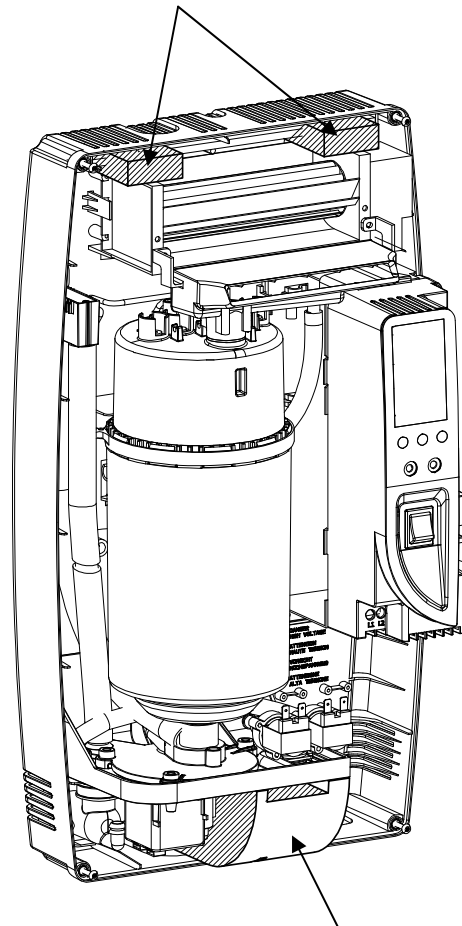

REMOVE BEFORE INSTALLING

IMPORTANT WARNINGS

We wish to save you time and money!
We can assure you that the thorough reading of this manual will guarantee correct installation and safe use of the product described.



BEFORE INSTALLING OR HANDLING THE HUMIDIFIER PLEASE CAREFULLY READ AND FOLLOW THE INSTRUCTIONS AND SAFETY STANDARDS DESCRIBED IN THIS MANUAL AND ON THE LABELS ATTACHED TO THE *Elite Steam*.

CAUTION: ALWAYS DISCONNECT THE MAIN POWER BEFORE OPENING OR SERVICING THE HUMIDIFIER!

Elite Steam produces non-pressurized steam by means of electrodes immersed in the water contained in the plastic steam generator cylinder. Electric current passes through the water between the electrodes, heating the water into steam, which is then used to humidify the air.

The quality of the water used affects the operation of this unit, so the *Elite Steam* may be supplied with untreated water, as long as this is drinkable and not softened or demineralized. The water converted into steam is automatically replaced through an electric fill valve. Periodically, based on the water quality, the unit will also drain some water to dilute the build-up of minerals in the steam generator. In cases of high water mineral content, an activated carbon filter in series with a particulate filter, no more than 5 microns is suggested.

This humidifier has been designed exclusively to directly humidify rooms or ducts, using a distribution system. The installation, use and maintenance operations must be carried out according to the instructions contained in this manual and on the labels applied internally and externally.

IMPORTANT: BEFORE beginning installation:

- Check for shipping damage to cartons. Mark the shipping waybill accordingly.
- Open cartons and check for any hidden damage. Mark the shipping waybill accordingly.
- Check packing slip to ensure all items have been received. Notify GENERAL FILTERS, INC. of any shortages or damaged parts. **You must notify General Filters, Inc. within 5 working days of any shortages.**

CAUTION: ELECTRIC SHOCK HAZARD! The humidifier has components under power inside!

CAUTION: SCALDING HAZARD! The humidifier has hot parts (100°C/ 212°F)

WARNING: Install the humidifier out of the reach of children.

The humidifier must be installed in accordance with all local and national standards.

All service and/or maintenance operations must be performed by qualified personnel who are aware of the necessary precautions and are capable of performing the operations correctly.

Disconnect the humidifier from the main power supply before accessing any internal parts.

The conditions of the environment and the power supply voltage must comply with the specified values listed on the data label in the humidifier.

All other uses and modifications made to the humidifier that are not authorized by the manufacturer are considered incorrect, and the manufacturer assumes no liability for the consequences of any such unauthorized use.

Please note that the humidifier contains powered electrical devices and hot surfaces.

The humidifier is made of metallic and plastic parts. All parts must be disposed of according to the local and national standards for waste disposal.

WARNING: Your humidifier requires water to operate. Do NOT mount it above materials or machinery that could be damaged if a leak occurs. General Filters, Inc. assumes no responsibility for consequential or inconsequential damage as a result of any leaks.

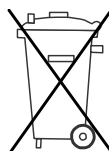

Disposal of the parts of the humidifier: the humidifier is made up of metallic and plastic parts. All parts must be disposed of according to the local standards on waste disposal.

CONTENTS

1. <u>How The Elite Steam Works</u>	6
1.1 Basic Operation	6
1.2 Cylinder Life	7
1.3 Calculating Humidity Load	7
2. <u>Models</u>	8
3. <u>INSTALLATION</u>	9
3.1 Positioning	9
3.2 Mounting	9
3.3 Plumbing	11
3.4 Steam distribution	12
3.5 Power wiring	15
3.6 Control wiring	15
3.7 Wiring Connections:	17
4. <u>START-UP</u>	18
4.1 Startup Checklist	18
4.2 The Elite Steam Controller	18
4.3 Starting Elite Steam	18
4.4 Starting with a new cylinder	18
5. <u>OPERATING ELITE STEAM</u>	19
5.1 Displaying Information	19
5.2 Changing The Maximum Production	19
5.3 Activating Manual Drain	19
5.4 Resetting the hour counter	19
5.5 Using the E2 Humidistat	20
5.6 Alarms	20
6. <u>TROUBLE SHOOTING</u>	21
7. <u>Maintenance</u>	22
7.1 Periodic checks	22
7.2 Cylinder maintenance	22
7.3 Replacement Parts	23
8. <u>TECHNICAL SPECIFICATIONS</u>	24
9. <u>LIMITED WARRANTY</u>	25

1. HOW THE ELITE STEAM WORKS

1.1 Basic Operation

Elite Steam is an electrode humidifier. It produces steam for humidification by passing electric current through the water between metal electrodes in the plastic steam generator cylinder. There are no heating elements. Steam output is directly proportional to the conductivity of the water, and the amount of electrode immersed in the water.

On a call for humidity, the *Elite Steam* controller will open the water fill valve (1) and allow water to enter the cylinder. A flow restrictor (4) prevents the unit from filling too quickly or with too much pressure. The water flows up the fill tube (2) and into the fill cup (3). Water then flows over the dam in the fill cup (3), which creates a 1" air gap to prevent backflow of contaminated water into the feed lines, and through the fill tube (6) and into the bottom of the steam cylinder (5). Any backflow or overflow of water travels through the overflow hose (13) to the drain.

As the water fills the cylinder, it will reach the electrodes (7) and current will begin to flow. As the water continues to fill the cylinder, the current will increase, and this is monitored by an amperage transformer connected to one of the power wires and located on the electronic controller. When the desired current is reached, the fill valve will close (1) and the water will then begin to warm and produce steam. If the water reaches the cylinder full probes (9) or if current rises too much, the drain pump (11) will be activated to drain away some water and reduce the current flow to acceptable levels. Note that, any time the drain pump is activated, the tempering valve (10) will be opened for tempering the hot drained water down to 140 degrees F / 60 degrees C in accordance to local and national standards.

Periodically, based on the incoming water conductivity, the unit will run drain pump (11) and drain some water to reduce the mineral concentration. Every 120 hours the unit automatically drains to remove mineral sediment on the bottom of the cylinder. A strainer (12) in the cylinder helps to prevent mineral debris from jamming the drain pump (11). In case *Elite Steam* remains powered but idle, i.e. without producing steam, for more than 72 hours (3 days), the cylinder will be emptied to not have stagnant water inside.

If there is no water in the cylinder, there will be no current flow and no steam production. The electrodes do not burn out, but they will eventually become completely coated with mineral and the cylinder will then need to be replaced. Cleaning cylinders may cause electrode damage, therefore voiding its warranty. See 7.2.2 maintenance section on page 21.

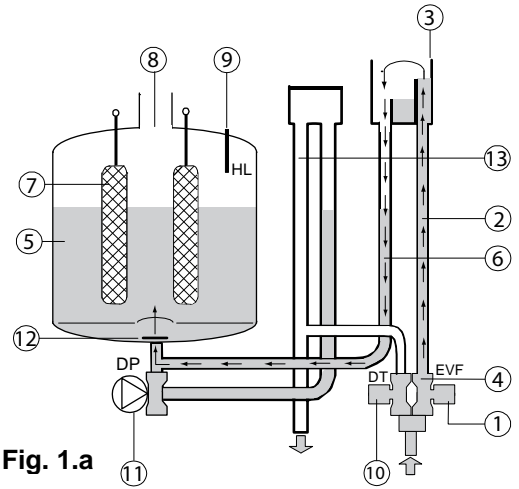

Fig. 1.a

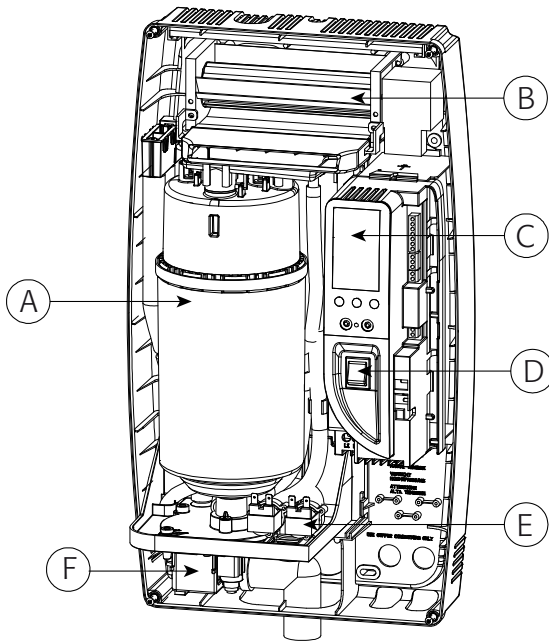

Fig. 1.b

No.	Description
A	Steam generator cylinder
B	Room blower/manifold (optional)
C	User interface/display
D	On/Off, SET buttons
E	Fill & tempering valves
F	Drain pump

1.2 Cylinder Life

1.2.1 Basics of the Steam Cylinder

The Steam Cylinder is the engine of the humidifier. As the humidifier operates water is evaporated and minerals are left behind. Much of these minerals are removed through the cylinder drain. Some are deposited on the walls of the cylinder and the cylinder electrodes. When a lower section of the electrodes develop a thick coating, the water level is raised to expose clean electrode surface. Eventually minerals cover the electrodes' entire length with a thick coating and little electrical current can pass between them resulting in poor steam output. The humidifier can sense the low amperage and will display the E6 Cylinder Exhausted error code. There are several factors that influence cylinder life.

1.2.2 Water

Characteristics of water influence cylinder life and can vary greatly from place to place. Total mineral content of the water is important. Equally important is what minerals are present in the water. Most water conditions result in flaky scale that eventually fills the bottom of the cylinder until it can no longer function. Water with high silica content can result in a thin glass-like coating on the electrodes that is highly insulating resulting in shorter cylinder life. **Only cold water is to be used. Water conductivity that is not matched to the correct cylinder will shorten cylinder life.**

1.2.3 Water Filtration

Typically additional filtration of the incoming water supply is not necessary. If, however, mineral content is known to reduce cylinder life excessively or if cylinder life proves insufficient then water filtration can be added. In most cases the addition of a two element water filter can improve cylinder life. The filter should contain an activated carbon element and a particulate filter element rated for 5 microns or less. Micron is a size measurement. The filter system should have a flow rate of at least 2 gpm. The activated carbon will absorb much of the mineral content while the particulate filter will catch any granular material or sediment. It is important to remember that the increase in cylinder life will be accompanied by the need to replace filter elements with each cylinder change.

1.2.4 Humidity Load and Cylinder Life

Humidity load demands have an effect on cylinder life. Normal installations where humidity capacity is properly sized require only intermittent periods where full humidifier capacity is required. This allows the water level in the cylinder to be increased only as electrode segments become insulated. This tends to maximize cylinder life.

Extraordinary installations that require constant operation at full capacity reduce cylinder life. The water level in the cylinder is, on average, much higher, and the electrodes become completely insulated more quickly. Installations like this may result in cylinder life of less than 1000 hours.

The importance of providing adequate humidifier capacity should not be underestimated.

1.2.5 Maximum Production

Another factor affecting cylinder life is the maximum production setting. A higher production rate will result in a shorter cylinder life. For this reason DS-25 and RS-25 units are preset from the factory at 70%. Further reductions in Maximum Production will extend cylinder life. See Figure 1.c.

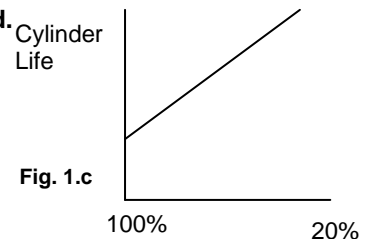

1.2.6 Structures Under Construction

In high end construction projects, humidification is often required while the structure is being finished. Humidification is necessary to protect and stabilize wood floors, trim and decoration. Humidification load, however, in an unfinished structure may be five to eight times higher than when finished. Elite Steam humidifiers may be operated while construction is underway but, reduced cylinder life is to be expected and budgeted for. **Good practice dictates that the steam cylinders also be replaced once the project is complete.**

1.3 Calculating Humidity Load

1.3.1 Steps to Determine Humidity Load

Total Square Footage
 x Average Ceiling Height
 x Factor From Table 1.2
x 1.05 for each Fireplace
 Humidity Load in lbs./hour

x 2.88 convert to gallons/day
 Gallons per Day Humidity Load

Table 1.2 Pounds of Moisture / Hour / Cubic Foot *

Indoor Air Temp °F	Indoor RH%			
	35%	40%	45%	50%
68	0.00015	0.00018	0.00021	0.00024
70	0.00017	0.00020	0.00023	0.00026
72	0.00019	0.00022	0.00025	0.00028

* Based on .5 air changes per hour.

*Based on .5 air changes per hour.

2. MODELS

There are two basic models available in two voltages. **Duct models require selection of an additional kit.**

Duct Steam Injection



Fig. 2.a

Room Steam Discharge



Fig. 2.b

MODEL LIST

PART NUMBER	DESCRIPTION	PARTS INCLUDED
RS 15P Fig. 2.b	Room steam discharge, 15 gallons per day (5.5 Lbs per hour) 115-120v	Complete Humidifier. E2 humidistat, code valve, water fill connector, water supply tubing
RS 25 Fig. 2.b	Room steam discharge, 35 gallons per day (12 Lbs per hour) 220-240v	Complete Humidifier. E2 humidistat, code valve, water fill connector, water supply tubing
DS 15P Fig. 2.a	Duct steam injection 15 gallons Humidifier only, Kit selection required per day (5.5 Lbs per hour) 115-120v	Humidifier only, Kit selection required
DS 25 Fig. 2.a	Duct steam injection 35 gallons per day (12 Lbs per hour) 220-240v	Humidifier only, Kit selection required
DMNKIT (not shown)	Duct mount kit	8 ft. steam hose, nozzle, E2 humidistat, code valve, water fill connector, condensate hose, water supply tubing, air proving pressure switch.
RMB 15 (not shown)	Remote mount blower kit for DS 15	12 ft. steam hose, E2 humidistat, code valve, condensate hose, water fill connector, water supply tubing, and thru-the wall sleeve with 120v blower and grille pkg.
RMB 35 (not shown)	Remote mount blower kit for DS 25	12 ft. steam hose, E2 humidistat, code valve, condensate hose, water fill connector, water supply tubing, and thru-the wall sleeve with 240v blower and grille pkg.

3. INSTALLATION

3.1 Positioning

The **Elite Steam** has been designed for wall mounting and, since it is an atmospheric steam humidifier, should be placed close to the point where the steam will be used, to minimize the steam hose length (and the amount of condensate). **Certain clearances must be maintained around the unit for safety and maintenance.**

Duct Steam Injection

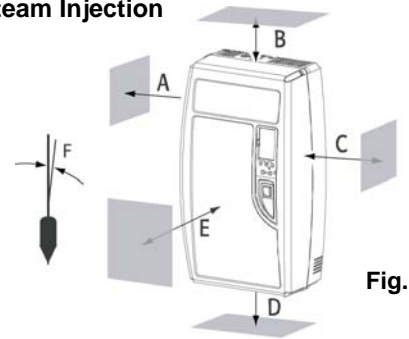

Fig. 3.a

	Millimeters	Inch
A	(150 mm)	6"
B	(150 mm)	6"
C	(150mm)	6"
D	(150 mm)	6"
E	(600 mm)	24"
F	max. 0.2°	

Tab. 3.a

3.2 Mounting

3.2.1 Removing the front cover

The front cover is secured by four screws located at the four corners of the unit. Use a phillips head screwdriver to remove the four cover screws. Then simply pull the front cover away from the back part of the unit. Return it in reverse order.

Be careful not to over-tighten the screws.

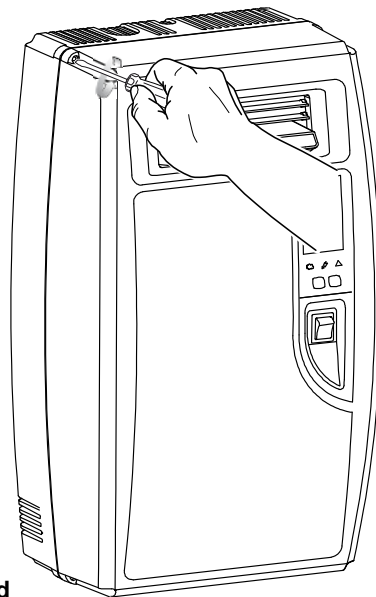

Fig. 3.d

Room Steam Discharge

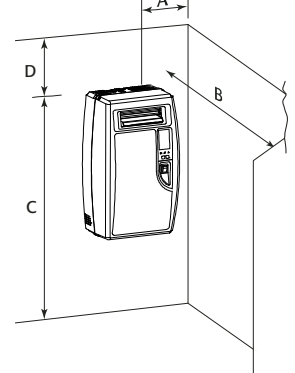

Fig. 3.b

	Millimeters	Inch
A	150 mm	6"
B	1800 mm	72"
C	1800mm	72"
D	600 mm	24"

Tab. 3.b

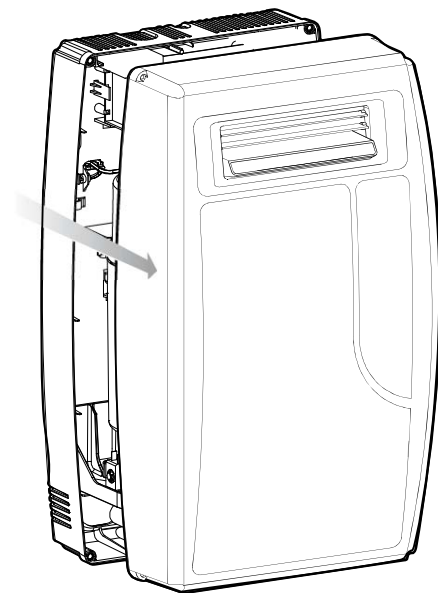

Fig. 3.e

Unit Dimensions: Duct and Room Units

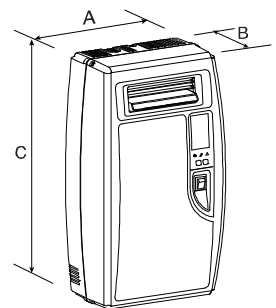

Fig. 3.c

	Millimeters	Inch
A	341 mm	13.5"
B	204 mm	8.1"
C	600 mm	23.7"
	Kilograms	Pounds
Weight empty	8kg	18 lbs
Weight packaged	10kg	22 lbs
Weight installed with water	12kg	26 lbs

Tab. 3.c

3.2.2 Fastening to the wall

Drill the wall according to the drilling template supplied; then secure Elite Steam firmly to the wall by the screws and anchors supplied.

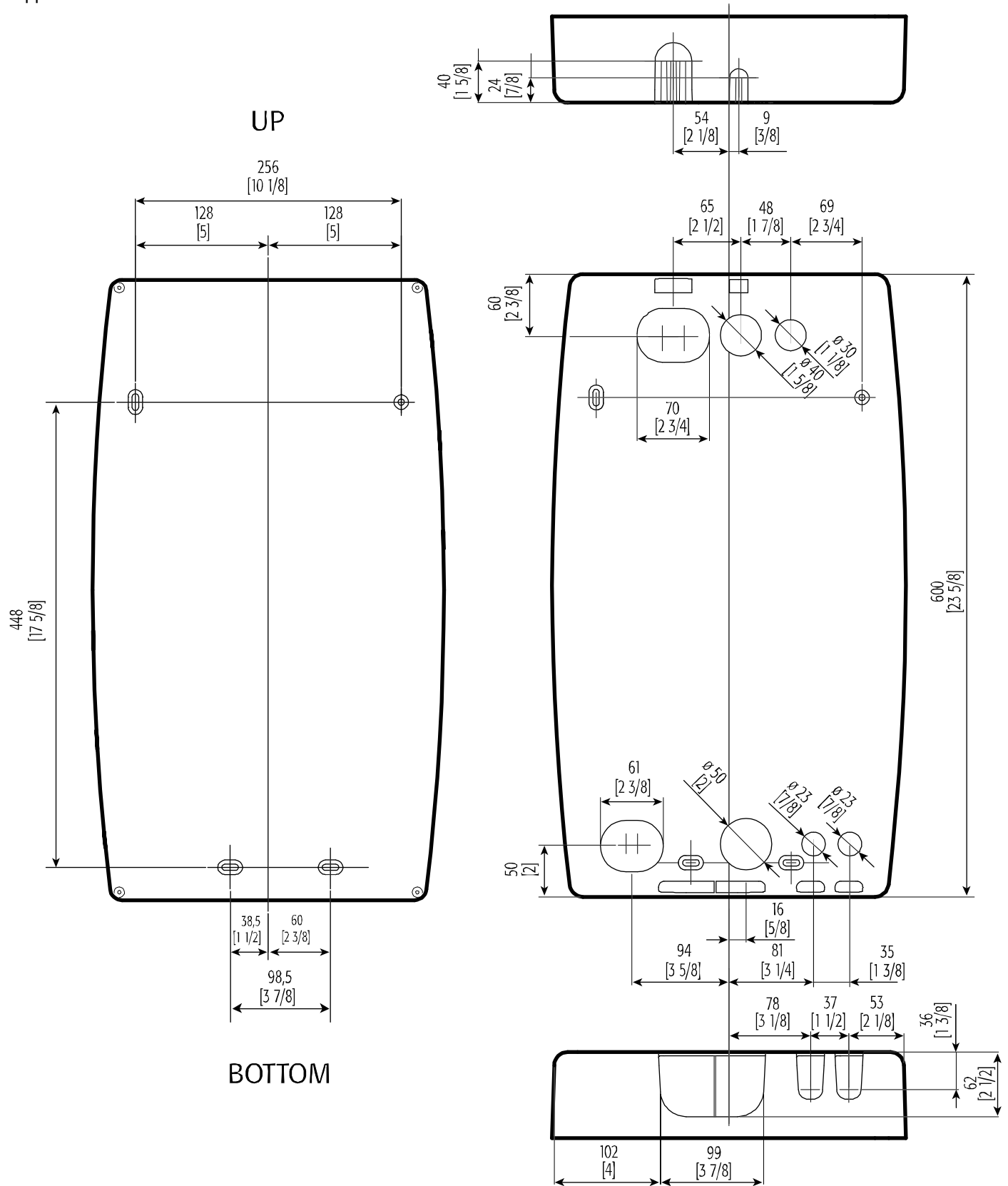

Fig. 3.f

3.3 Plumbing

3.3.1 Water Characteristic Requirements

The humidifier must be supplied with water with the following characteristics:

- pressure between 20psi and 110psi or 0.1 and 0.8 MPa (1 and 8 bar)
- temperature between 33°F and 104°F or 1°C and 40°C
- flow-rate minimum of 0.45 L/min or 0.21gpm
- hardness no greater than 40°FH (equal to 400 ppm³ of CaCO), conductivity: from 125 to 1250 μS/cm
- absence of organic compounds
- the characteristics of the water of supply must fall within the following limits:

LIMIT VALUES FOR LOW SALT CONTENT WATER

	Units	Min	Max
Hydrogen ions (pH)		7	8.5
Specific conductivity (R,20°C)	μS/cm	300	
Total dissolved solids (c R)	mg/l	(*)	(*)
Dry residue at 180°C	mg/l	(*)	(*)
Total hardness	mg/l CaC ₂ O	150	400
Temporary hardness	mg/l CaC ₂ O	=	200
Iron + Manganese	mg/l Fe + Mn	=	0.2
Chlorides	ppm Cl	=	30
Chlorides	mg/Si ₂ O	=	20
Chlorine residue	mg/l Cl-	=	0.2
Calcium sulphate	mg/l CaS ₄ O	=	100

Tab.3.d

LIMIT VALUES FOR LOW NORMAL WATER

	Units	Min	Max
Hydrogen ions (pH)		7	8.5
Specific conductivity (R,20°C)	μS/cm	125	500
Total dissolved solids (c R)	mg/l	(*)	(*)
Dry residue at 180°C	mg/l	(*)	(*)
Total hardness	mg/l CaC ₂ O	0	200
Temporary hardness	mg/l CaC ₂ O	=	150
Iron + Manganese	mg/l Fe + Mn	=	0.2
Chlorides	ppm Cl	=	20
Chlorides	mg/Si ₂ O	=	20
Chlorine residue	mg/l Cl-	=	0.2
Calcium sulphate	mg/l CaS ₄ O	=	60

Tab.3.e

(*) Values dependent on the specific conductivity: in general: $cR \approx 0.65 \cdot \sigma R, 20^\circ C$; $R180 \approx 0.9 \cdot \sigma R, 20^\circ C$

Note: There is no relationship between the hardness and conductivity of water.

Water Conductivity must be matched by specifications of the steam cylinder. Check or know the water conductivity of the proposed site before installation. Replace the steam cylinder before startup if not correct. See Table 3.f right.

ELITE STEAM models	Conductivity μS/cm	Steam Cylinder
DS25, RS25, DS25LC, RS25LC, DS35, RS35	300-1250	35-14
DS25, RS25, DS25LC, RS25LC, DS35, RS35	125-500	35-15
DS15P, RS15P, DS15, RS15	125-1250	15-14
DS20A, RS20A	300-1250	20-14A
DS20A, RS20A	125-500	35-14

Tab.3.f

The following water types are not acceptable:

1. Softened water as this will lead to foam, electrode corrosion and greatly shortened cylinder life.
2. Water containing disinfectants or corrosion inhibitors, as these are potential irritants.
3. Industrial water, boiler water or water from cooling circuits.
4. Any potentially chemically or bacteriologically contaminated water.
5. Heated water.

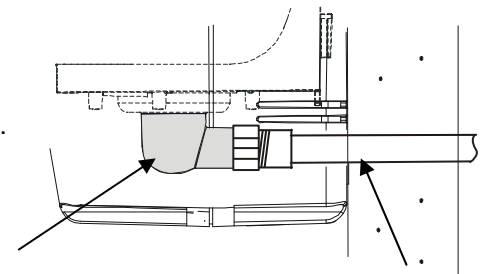

Water drain outlet

Fig. 3.g

Extension tube

3.3.2 Water Supply Connection

We recommend the connection between the fill valve and the water supply line by a soft poly hose capable of absorbing the water hammering in order to avoid damage to the fill valve itself. The water line may be routed through the back or through the bottom of the unit. With poly tubing, a tubing support must be used to prevent tubing collapse and leaks. The fitting then threads onto the fill valve inlet located on the bottom of the humidifier using a 3/4" G connection. **Note that there is a strainer built into the fill valve fitting underneath the unit, which will require periodic cleaning, so be sure to allow clearance for access.**

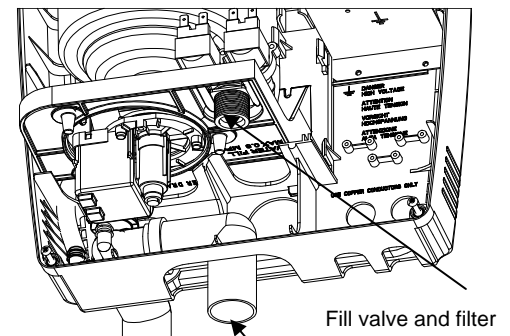

Fig. 3.h

Fill valve and filter

Water drain

3.3.3 Water Drain

The Elite Steam also requires a connection to a drain. The drain line may be routed out the back or bottom of the unit using the included angle fitting. The drain line can be 1-1/4" PVC, CPVC or polypropylene. The drain line is not glued or otherwise attached to the humidifier so it must be supported by itself. A coupling should be used. The Elite Steam includes a drain tempering valve that runs whenever the drain pump runs and flushes cool water into the drain line to insure the drain water temperature never exceeds 60°C or 140°F.

The drain water characteristics are:

- Drain Rate 26.8 liter per minute or 7.1 gallons per minute
- Connection 32mm or 1 1/4"
- Temperature 60°C or 140°F

NOTE: Drain line must be trapped under the unit to prevent flash steam from condensing in the unit cabinet.

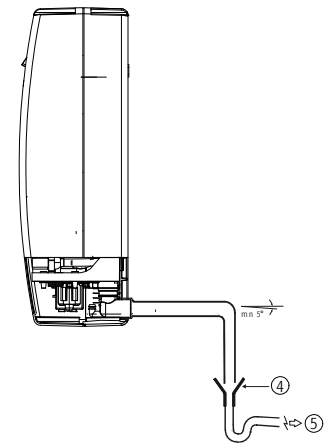

3.3.4 Drain Connections

When using a rear outlet drain passing through drywall, we suggest using a 1 1/4" extension tube type SJ (see Fig. 3.f). When using a bottom outlet drain, attach the included 90° fitting to the drain outlet. The drain outlet may be rotated. Then connect a 1 1/4" trap adaptor to connect to drain pipe.

IMPORTANT WARNING: The drain pipe must be free without back pressure. We recommend an external anti-flooding device not supplied to protect from faults of external hydraulic circuits.

3.4 Steam distribution

3.4.1 Duct steam injection (Additional kit required)

The maximum allowed duct static pressure is 2 in WC.

The **Elite Steam** duct injection models include a plastic duct injection nozzle. See Fig. 3.i

	Millimeters	Inch
A	31.5 mm	1.24"
B	50 mm	1.96"
C	56 mm	2.20"
D	57.5 mm	2.26"
E	100 mm	3.93"
F	∅ 8 mm	∅ 0.31"
G	∅ 22 mm	∅ 0.86"
H	∅ 30 mm	∅ 1.18"
I	12 or 22 mm	0.47 or 0.87"

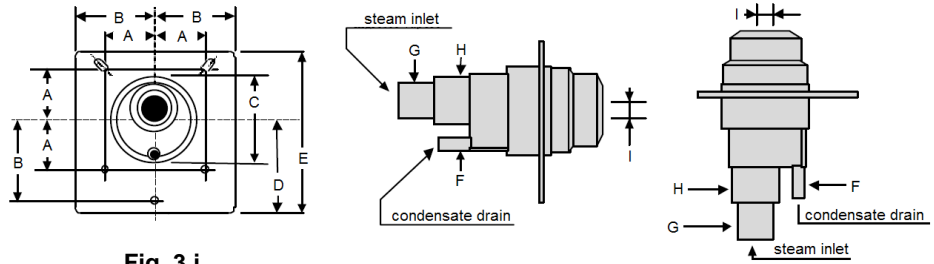

Fig. 3.i

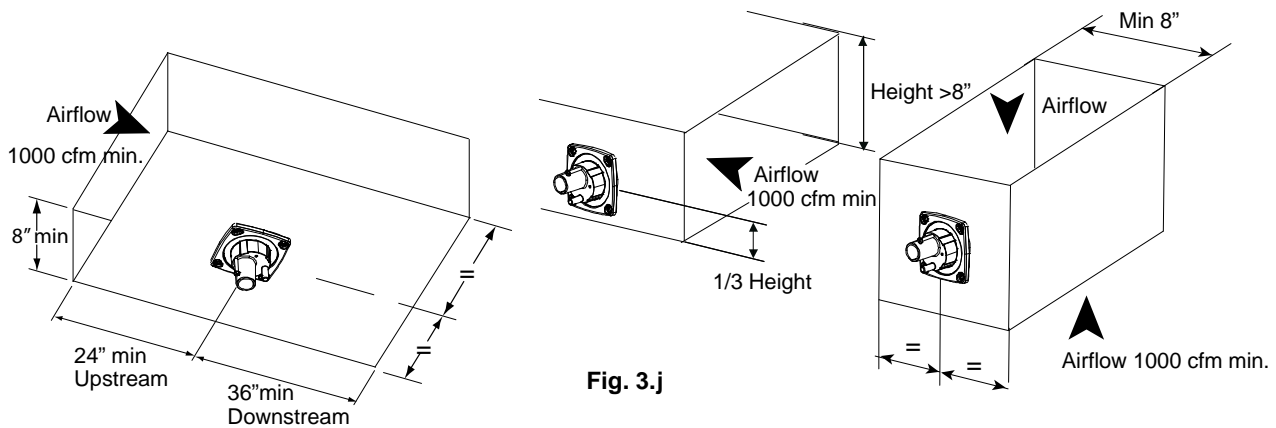

Fig. 3.j

3.4.2 Duct Distribution (Additional kit required)

If a duct steam distribution nozzle is to be used, select an accessible location on the duct, allowing at least 36" of straight duct (no elbows or obstructions) after the point where the nozzle will be installed and the clearances can be maintained as per the following drawings. See Fig.3.j To mount the steam nozzle, cut or drill a 2-1/2" hole in the duct. Apply caulk to the to the mounting plate of the nozzle. Attach the nozzle to the duct using 4 #10 sheet metal screws (supplied). Nozzle must be level or vertical with condensate outlet to the bottom.

IMPORTANT: Allow 1 M (3 feet) of straight duct downstream of the distributor pipes and nozzles for absorption of the steam. Always allow 0.6M (2 feet) of straight duct upstream of the distributor pipes for evaporation of the steam. Turbulent air flow may require longer lengths.

Optional stainless steel duct distributor pipe:

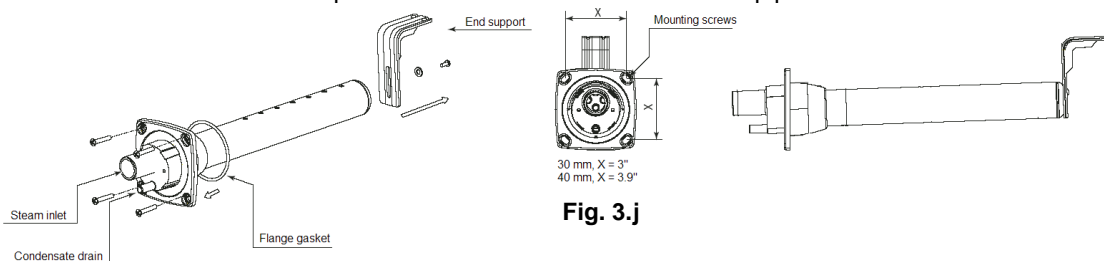

Fig. 3.k

To install the distributor pipes:

1. Cut a round hole in the side of the duct to match the steam pipe and condensate return.
2. Apply silicone sealant to the mounting plate and insert the pipe through the hole and secure it with sheet metal screws. See Fig. 3.k
3. Connect the steam and condensate hoses using the hose clamps supplied.
(Note: end support bracket supplied only with 36" and longer distributors.)

3.4.3 Return Condensate Connection

The return condensate hose from the nozzle, etc. must be trapped. Coil the hose into a vertical loop and secure it below the nozzle, etc. This trap prevents steam from being released into the cabinet. The hose end may be run through the knockout at the top of the humidifier and be inserted into the hole located on top of the fill cup. The hole may be enlarged to suit. See Fig.3.l.

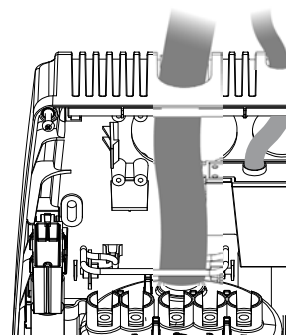

Fig. 3.l

3.4.4 Steam Hoses

IMPORTANT WARNING: NINETY PERCENT (90%) OF ALL OPERATION PROBLEMS ARE CREATED BY IMPROPER STEAM PIPING FROM THE HUMIDIFIER UNIT TO THE DUCT DISTRIBUTOR PIPES.

To avoid these problems, remember one simple fact when running the steam hose: steam naturally flows up hill, and condensate naturally flows downhill. Run the steam hose or piping to avoid any kinks, sharp elbows, or low spots that could collect or restrict the flow of steam to the distributor pipe, or the flow of condensate back to the humidifier. Support the hose adequately to avoid sags. The following diagrams are to provide you with some guidelines. If you have a situation you are unsure of, *please* contact the factory for instructions.

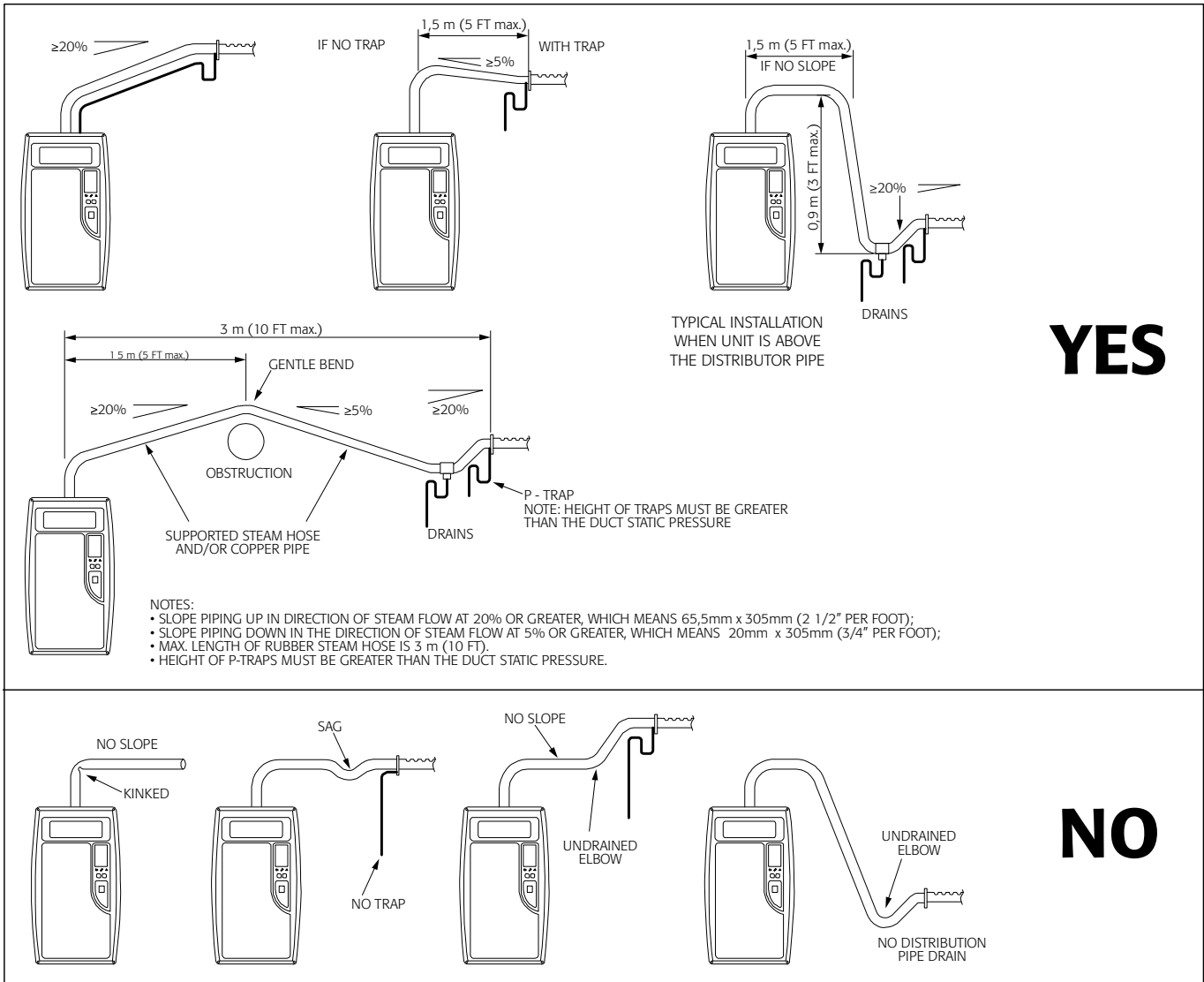

Fig. 3.m

IMPORTANT: Maximum length of rubber steam hose is 4m (12 feet.). Insulated copper tubing may be up to 6m(20feet) in length. In all cases, minimize sharp bends and elbows. Use 2 - 45° elbows instead of 90°s.
Hose inner diameter = 7/8" (22 mm); Hose outer diameter = 1-1/4" (30 mm).

3.4.4 Remote Mount Blower

Remote Mount Blowers, are used to distribute the steam directly into the room. The drawings show the **minimum recommended distances** to avoid the flow of humidified air from coming into direct contact with persons, lights, electrical appliances, and surfaces before the steam has been totally absorbed by the environment. For further details on the assembly, the electrical connections and the use of a Remote Mount Blower, please refer to the specific instruction manual.

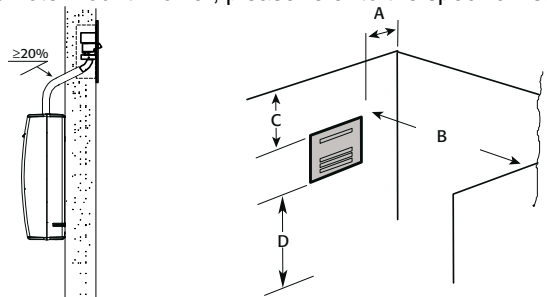

Fig. 3.n

	Millimeters	Inch
A	150 mm	6"
B	1800 mm	72"
C	600 mm	24"
D	2100 mm	84"

Tab. 3.g

3.5 Power wiring

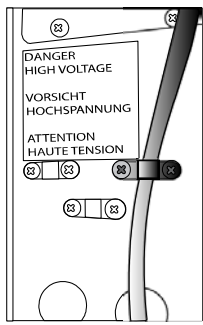

Fig. 3.o

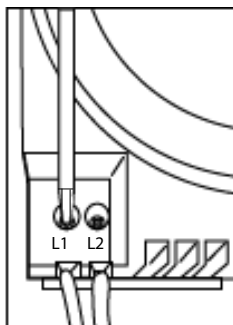

Fig. 3.p

Check that the power supply voltage to be connected matches the value indicated on the rating plate inside the electrical panel.

Insert the power and ground connection cables into the electrical panel compartment using the strain reliefs supplied, and connect to the terminals. An external fused disconnect must be installed. See Fig. 3.o

All wiring must be in accordance with local, state and national electric codes.

NOTE: to avoid unwanted interference, the power cables should be kept separate from any control wiring.

NOTE: Tolerance allowed on main voltage = -15% to +10%.

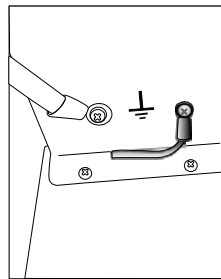

Fig. 3.q

Connect power wires to the power terminal block located at the bottom left of the control module, polarity does not matter. See Fig. 3.p

Connect the ground wire to the unit's chassis ground, located just behind the power wiring terminal block. See Fig. 3.q

Model	Power supply (single phase)	Steam Output (lbs/hr)	Steam Output (kg/h)	POWER (kW)	CURRENT (A)	EXTERNAL POWER WIRES	EXTERNAL FUSE (A) OR BRAKER
DS15	110Vac 50/60Hz	5.5	2.5	1.80	16.40	AWG10	25
RS15	110Vac 50/60Hz	5.5	2.5	1.80	16.40	AWG10	25
DS35	230Vac 50/60Hz	12	5.4	3.89	16.95	AWG10	25
RS35	230Vac 50/60Hz	12	5.4	3.89	16.95	AWG10	25

3.6 Control wiring

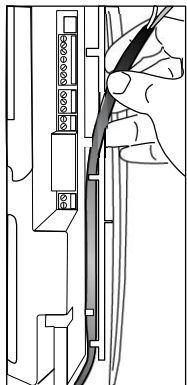

Fig. 3.r

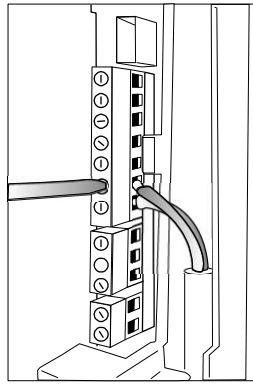

Fig. 3.s

Elite Steam allows connection of any simple or automatic humidistat, and safety devices such as high-limit humidistat, air flow proving switch, and remote on/off. The humidifier is operated by the closing of a mechanical humidistat H, or by the closing of a voltage-free remote contact, or alternatively by a combination of both. The diagrams in the figures show the connections to be made on the terminal block, in case of:

Fig. 3.u Operation performed by a simple enabling contact;

Fig. 3.t Operation controlled by an external mechanical humidistat;

Fig. 3.v A combination of both humidistat and pressure switch (most common).

Contact AB-AB:

- closed: humidifier enabled to produce steam (production starts when humidistat closes);
- open: steam production is immediately stopped.

The remote on/off contact is usually a series of external potential-free contacts that enable the humidifier to produce steam when all of them are closed, indicating the duct/AHU is ready to accept steam. Connect the 12500 Pressure Switch NO and C terminals to the AB-AB contacts.

For example,

- fan contact closes when fan is running;
- downstream cooling coil contact closes when coil is off;
- etc.

Contact IN-GND:

- closed: steam production starts if contact AB-AB is closed
- open: steam production is stopped after 5 sec.

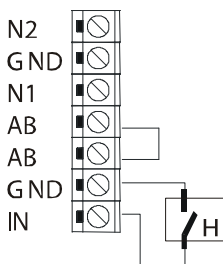

Fig. 3.t

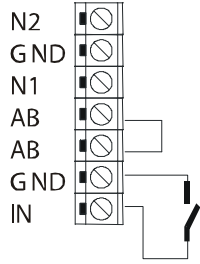

Fig. 3.u

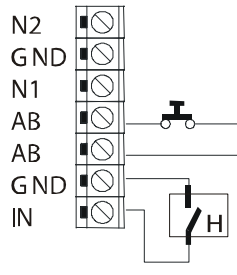

Fig. 3.v

3.6.1 Connect the E2 Humidistat for On/Off Operation:

1. Remove the humidistat from the base, squeeze the louvered base at the top and bottom. To remove the humidistat from the wall, lift up on the humidistat and pivot top away from wall.
2. Before wall mounting, please remove the black foam gasket.
3. Before return air duct mounting, please remove the breakout piece.
4. If return air duct mounting, route wires between humidistat and base.
5. Mount the sensor outside the house. Do not mount on South side of the house or in direct sunlight. Place at least 4 feet away from any exhaust vent. If in air intake, place 1 foot or closer to outside wall. Place at least 6" higher than possible snow. Do not route sensor wire near high voltage wires.
6. Connect the GND-IN terminals on the humidifier to the HUM terminals on the E2 Humidistat. Connect the GND-24V terminals to the ACL-ACN terminals on the E2 Humidistat. see Fig.3.x

3.6.2 Modulating Operation

Connect an external 0...10 Vdc modulating input between terminals IN-GND. Connect any Safety Switches (high-limit, air flow switch, remote on/off) in series to terminals AB-AB. If no safety switches are used, then a jumper must be installed between AB-AB. DO NOT apply any voltage to AB-AB.

3.6.3 Connect the ADCD humidistat for Modulating Operation

To select signal modulating see Fig 3.y Connect the power supply to the ADCD G and O terminals, using the terminal GND and 24V on the Elite Steam. **Note MODULATING OPERATION requires a change in signal type. See SEC. 5.1.1 page 19.**

Connect an external signal to the ADCD using the terminal IN from the Elite Steam and AOUT in ADCD. See the diagram below.

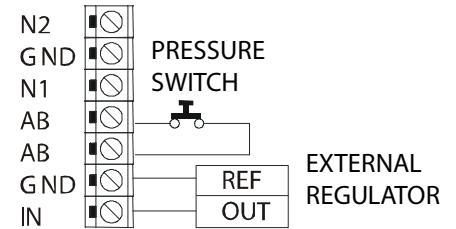

Fig. 3.w

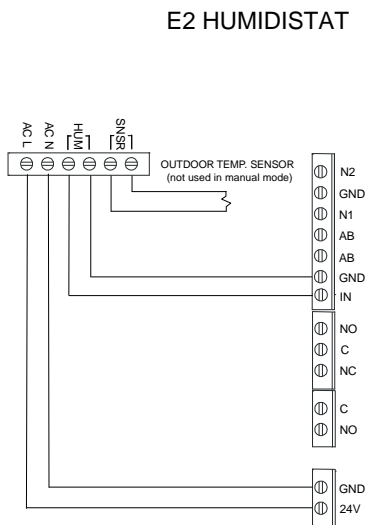

Fig. 3.x

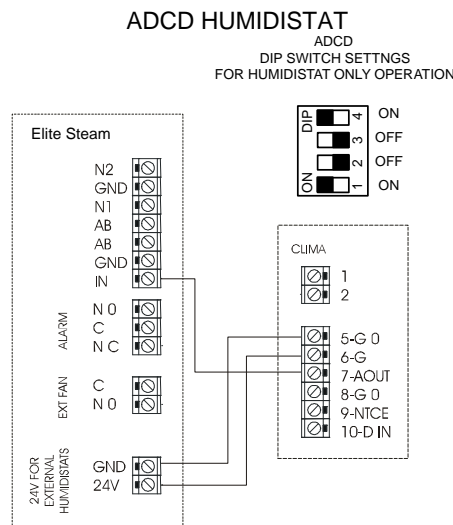

Fig. 3.y

FURNACE BLOWER OPERATION

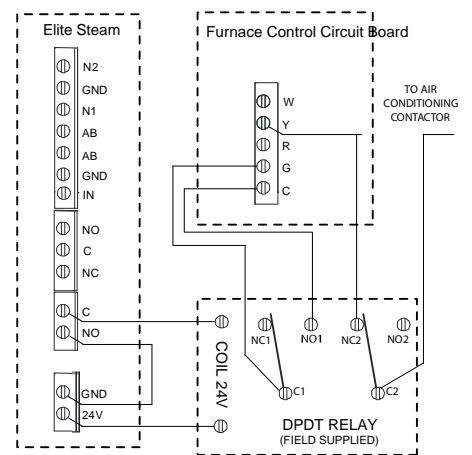

Fig. 3.z

3.6.4 Safety and High Limit Switches

Remove the jumper between terminals AB-AB and connect any simple high-limits, air flow switch, 12500 pressure switch, and remote contacts in series to terminals AB-AB; otherwise, if no such dry contacts are available, the jumper must remain in place between terminals AB-AB. DO NOT apply any voltage to AB-AB.

Thread the control wiring through the bottom of the unit, and the strain relief (see photo at top of previous page), and then up the side of the control module to the top right wiring terminal blocks. Connect the control wiring to the control wiring terminal blocks found at the top right side of the control module.

3.7 Wiring Connections:

Terminals	Functions	Electrical specifications
L1-L2 -GROUND	Power supply and Ground connections	Power supply 110 VAC 1-phase 50-60Hz 1.86kW or 230VAC 1-phase 50-60Hz 4.05kW
KEY	Programming port	Connecting to Programming port or supervisor
N1-GND- N2	NTC air proving sensor	Connection to NTC 2K and 10K to 20°C
AB-AB	Remote enabling input	Imposes an external NO contact ; Rmax=300 Ohm; Vmax=33 Vdc; Imax=6mA dc; humidifier enabled = contact closed
IN-GND	Control signal input	If programmed 0...10V: Input impedance 10 kohm If programmed ON-OFF: Vmax 33Vdc Imax = 5mA Rmax = 300 Ohm
NC-C-NO	NC alarm contact Common alarm contact NO alarm contact	250V; 8Amp max with resistive load; 4 Amp max with inductive load
NO-C	External fan relay	250V; 8Amp max with resistive load; 4 Amp max with inductive load
24GND	Power for external humidistat	Power supply for external humidistat 24 Vac; 2 Watt

3.7.1 Wiring diagram of controller

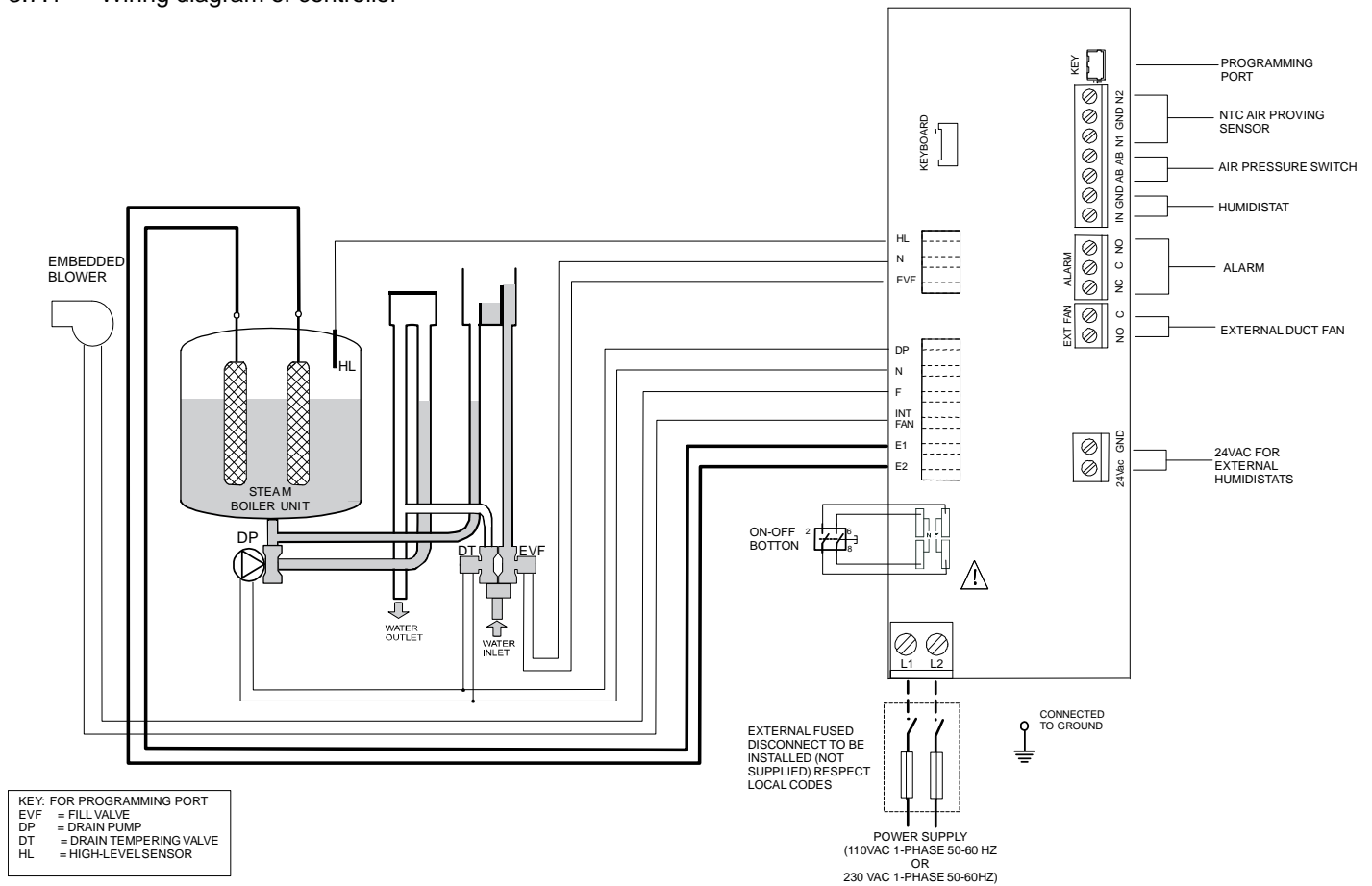

Fig. 3.z.1

4. START-UP

IMPORTANT WARNINGS:

1. Before starting, check that the humidifier is in perfect condition, that there are no water leaks and that the electrical parts are dry;
2. Do not connect power if the humidifier is damaged or even partially wet!

When installation is completed, flush the supply pipe for around 10 minutes by piping water directly into the drain, without sending it into the humidifier; this will eliminate any scale or residues that may cause foam when boiling.

4.1 Startup Checklist

Before starting the humidifier, the following should be checked:

- Water is connected, the line has been flushed, and external valves are open.
- Drain is connected, run to an open drain, and has a trap under the unit.
- Electricity is connected in accordance with instructions, local codes and data labels in the unit.
- The power fuses are installed and intact.
- All control wiring is done and tested.
- Airflow switch is wired to open on air flow loss.
- Hi-limit humidistat is wired to open on humidity rise above set point.
- Unit wires have been checked to make sure they and all connectors are tight from shipping.
- The steam hose(s) are run correctly with no sags or kinks and sloped properly according to the manual.
- Condensate hoses are run correctly with no sags or kinks and sloped properly according to the manual.

4.2 The Elite Steam Controller

The *Elite Steam* controller features a comprehensive information display that shows the operation of the system at a glance:

1.	Display is % of nominal capacity
2.	Maintenance
3.	Display is amperage (default)
4.	Steam is being produced
5.	Cylinder filling
6.	Foaming
7.	Water presence inside the cylinder
8.	Cylinder draining
9.	LEDs indicate: power (yellow), operation (green) and alarms (red)
10.	Drain button for manual draining of cylinder and confirming parameter values
11.	ON/OFF button
12.	Reset button to reset alarms and access parameters
13.	Level of output: 33%, 66%, 100%
14.	Fan relay is activated

The Elite Steam is now ready to operate.

4.3 Starting Elite Steam

- Insure that the external power is turned on.
- Push the top part of the On/Off button so that the I part is in. The yellow Power LED will be lit. The Elite Steam is now ready to operate.
- When there is a call for humidity, Elite Steam will close its power relays and send power to the electrodes in the plastic steam generator. The green Operation LED will light, indicating that operation has begun.

4.4 Starting with a new cylinder

When starting with a new cylinder, you should activate the cylinder cleaning function as follows:

1. Switch Elite Steam off.
2. Press and hold both buttons, “**reset**” and “**drain**”, and switch Elite Steam back on. When the wrench blinks  then release the two buttons.
3. Press and hold “**reset**” until the display shows 04.
WARNING: DO NOT confirm any value higher than 04. If 05 or higher is displayed, press “**reset**” until the display goes back to the normal operating mode and restart from step
4. Press “**drain**” (minimum 1 second): the cleaning starts.

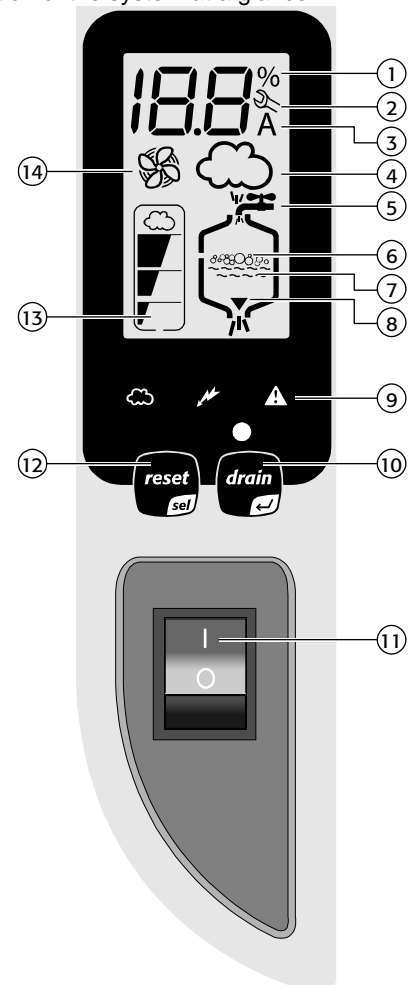

During the cleaning, the electrodes are powered and water is filled in until it touches the high-level sensor or the phase current equals 20A, whichever occurs first. After either of the events is detected, the boiler is fully discharged with the electrodes un-powered (the drain pump and the drain tempering valve are activated for 3 minutes). Warming the filling water helps washing out any mould release or dirt. General Filters, Inc. recommends to do two cleanings when starting a new boiler. After the cleaning ends, the humidifier starts the regular duty. When starting the unit with a new or empty cylinder, it may take a significant amount of time (hours) for the unit to build up enough mineral concentration to reach rated capacity. This time can be shortened by the addition of Alka-Seltzer through the steam outlet on top of the cylinder.

5. OPERATING ELITE STEAM

5.1 Displaying Information

By pressing the "reset" button for 2 seconds, the display will loop from amperage to production in % of the maximum production to the hour counter and back to amperage:



1. **Amperage:** it is the value of the current that flows through the water making it boiling off (default display)
2. **Production %:** it is the current production expressed as a percentage of the humidifier's capacity
3. **Hour counter,** expressed in tens; for instance, when the display shows 13 the real hour value will be between 130 and 139 hours.

5.1.1 Select Signal Type

The Elite Steam is preset for the included E Series humidistat (signal type 0). If the included humidistat is used, this section may be omitted. If another humidistat is used, review this section to see if changes are needed.

1. Switch Elite Steam off.
2. Press and hold both buttons "reset" and "drain" and switch Elite Steam back on. When the wrench blinks,  release the 2 buttons.
3. Press "Reset" until the display shows 02. WARNING: DO NOT confirm any value higher than 04. If 05 or higher is displayed, press "Reset" until the display goes back to the normal operating mode and restart from step 1.
4. Press "drain" (minimum 1 second) to confirm: the display shows "P1" then the current signal type and "set"
5. Press "Reset" to change signal type between 0 and 1:
 - 0 = On-Off humidistat such as the GeneralAire "M" or "E" series humidistat.
 - 1 = external 0...10 Vdc modulating signal such as the GeneralAire ADCD series humidistat
6. Press "drain" (minimum 1 second) when done to confirm the new value of P1 and exit to the normal operating mode.
7. Switch Elite Steam off: you can now proceed with connecting the control wiring.

5.2 Changing The Maximum Production

The maximum production can be adjusted between 20% to 100% of the nominal production in steps of 5% in order to suit the environment characteristics. DS25 and RS25 Maximum production is factory set at 70%.

1. Switch Elite Steam off.
2. Press both and hold both buttons "Reset" and "Drain", and switch Elite Steam back on. When the wrench blinks;  release the 2 buttons.
3. Press "reset" until the display shows 01. WARNING: DO NOT confirm any value higher than 04. If 05 or higher is displayed, press "Reset" until the display goes back to the normal operating mode and restart from step 1.
4. Press "drain" (minimum 1 second) the display shows "P0" then the current Maximum Production Percent and "set".
5. Press "reset" to change the Maximum Production in steps of 5% between 20% and 100%.
6. Press and hold "drain" (minimum 1 second) when done to confirm the new Maximum Production and exit to the normal operating mode.

5.3 Activating Manual Drain

Press and hold the "drain" button on the front of the unit until the cylinder is drained. Note: Water will continue to flow from the tempering valve after the cylinder is empty.

5.4 Resetting the hour counter



The hour counter should be reset every time the cylinder is changed in order to reset and restart the internal maintenance timer:



1. Switch Elite Steam off.
2. Press and hold both buttons "Reset" and "Drain" and switch Elite Steam back on. When the branch  blinks; release buttons.
3. Press and hold "reset" until the display shows 03. WARNING: DO NOT confirm any value higher than 04. If 05 or higher is displayed, press "reset" until the display goes back to the normal operating mode and restart from step 1.
4. Press "drain" (minimum 1 second) to confirm: the hour counter will be reset at once and Elite Steam will go back to the normal operating mode.

5.5 Using the E2 Humidistat

Press  to select **OFF**, **MANUAL** or **AUTO mode** (if outdoor sensor is connected).

OFF mode: The humidifier is turned off.

MANUAL mode: The E2 will work to maintain the single humidity selected. You can set your desired humidity level by pressing  or . The humidifier will turn ON or OFF according to your manual setting. (The humidifier will operate when the measured relative humidity falls more than 2% below the set point.) Humidity will have to be lowered when weather is colder or if condensation is suspected.







AUTO mode: The E2 will automatically raise the humidity as the outdoor temperature increases. This provides the highest possible humidity. The E2 will automatically lower the humidity as temperatures drop. This minimizes the risk of condensation on cold surfaces like windows. You can adjust the Auto Humidity Index Set Point from 0 (low) to 10 (high) by pressing  or . The Humidity Index is based on the outdoor temperature and indoor humidity. The humidifier will switch ON/OFF according to the calculated auto humidity index set point. Lower Index settings are for older homes with less insulation and vapor barriers. Higher Index settings are for newer homes with complete vapor barriers, triple pane windows and high R value insulation. If condensation occurs reduce Index setting by 2 points until condensation stops.

NOTE If the outdoor temperature sensor fails,  flashes and the unit will default to **MANUAL mode**.

To toggle between indoor / outdoor temperature and indoor humidity: Press .

To change the temperature unit: Press °C / °F.

To set the temperature / humidity offset in MANUAL or AUTO mode:

1. Simultaneously press  and  when viewing the temperature or humidity reading.
2. Use  or  to change the setting (-3 to 3).
3. Press  and  simultaneously or wait 5 seconds to confirm and move onto the next setting.

Lo or Hi will flash on the display when:

MEASUREMENT	LO	HI
Indoor temp.	Below 0°C (32°F)	Above 99°F(37°C)
Outdoor temp.	Below -40°C (-40°F)	Above 50°C (122°F)
Humidity	Below 10%	Above 90%

- If power is lost, current settings are retained.

WARNING: Do not allow excess humidification. Excess humidity can cause condensation and enable mold and mildew growth.

5.6 Alarms

In the event of an alarm, the red alarm LED will flash, the alarm relay will close, and the alarm code will flash in the display. Multiple alarms will flash in sequence, alternating with the main display. Pressing the sel button for 2 seconds will reset the alarms, although still active alarms will continue to display.

Dis play	Description	Action	Red Led	Alarm Relay	Notes
--	Remote on-off open	Unit disabled	Off	Off	
EE	Internal memory error	Unit disabled	On	On	
E0	Control board configuration not valid	Unit disabled	On	On	Turn off, check control board, reprogram
E1	High current alarm	Unit disabled	On	On	Turn off, check connections, check cylinder (no limescale bridges between electrodes, no electrodes short-circuited)
E2	Low production, low supply water conductivity or excessive foam/limescale in the cylinder	Unit disabled. Press "reset/sel" key for 1 seconds to reset.	On	On	Check supply water conductivity (too low?), replace the cylinder.
E4	Fill alarm, unable or slow fill (current does not increase within timeout)	Press "reset/sel" key for 1 seconds to reset, otherwise the warning will be reset automatically every 10 minutes until the supply water is available again.	On	On	Check water supply and fill valve; check drain pump for leakage
E5	Drain alarm, unable to drain (current does not decrease within timeout)	Press "reset/sel" key for 1 seconds to reset	On	On	Check drain pump and drain connection
E6	Cylinder exhausted (critical performance detected)	The warning is automatically reset if Elite Steam can produce the demand, otherwise turn off and then on.	Off	Off	Change cylinder (urgent)
E7	Foam detected	Press "reset/sel" key for 1 seconds to reset	Off	Off	If it continues, do some cleaning cycles (read chap. "Starting with a new cylinder")
E8	Cylinder lifetime expired (2000 hours)	Reset the hour counter (read chap. Resetting the hour counter")	Off	Off	Change the cylinder.
E9	High controller temperature (above 176 °F / 80 °C)	The warning is automatically reset if the temperature decreases below 176 °F / 80 °C.	Off	Off	Check the ambient temperature, replace the controller.

6. TROUBLE SHOOTING

Problem	Causes	Solutions
The humidifier does not turn on	<ol style="list-style-type: none"> 1. No electrical power 2. On/off switch of the humidifier in position 0 (open) 3. Control connectors improperly connected 4. Blown fuses 5. Transformer failure 	<ol style="list-style-type: none"> 1. Check the safety devices upstream from the humidifier and the presence of power 2. Close the switch on the panel: position I 3. Check that connectors are properly inserted in terminal block 4. Check the condition of fuses 5. Check that the proper voltage is connected and turned on
The humidifier does not start operation	<ol style="list-style-type: none"> 1. Remote ON/OFF contact open 2. The humidistat has not been connected correctly 3. Humidistat failure 4. Control signal not compatible with the type set 5. Value measured by the sensor/s higher than the corresponding set point 	<ol style="list-style-type: none"> 1. Close ON/OFF contacts 2. Check the external connection 3. Replace the humidistat
The humidifier fills with water without producing steam	<ol style="list-style-type: none"> 1. High steam back pressure 2. Fill valve strainer clogged 3. Mineral in the fill cup 4. Drain solenoid valve leaking 	<ol style="list-style-type: none"> 1. Check that the steam hose is not kinked or sagging, trapping condensate 2. Clean the fill valve strainer 3. Clean the fill cup 4. Check for voltage at the drain solenoid valve and/or drain solenoid replacement
The humidifier wets the duct	<ol style="list-style-type: none"> 1. The distributor is not installed correctly (too near the top of the duct or the condensate return is blocked) 2. Air flow rate is too low 3. Humidifier active when the fan in the duct is off 	<ol style="list-style-type: none"> 1. Check that the steam distributor is installed correctly 2. Increase air flow in duct or decrease PO maximum steam production setting 3. Check the connection of the device (flow switch or differential pressure switch) controlling the humidifier to the ventilation in the duct
The humidifier wets the floor below	<ol style="list-style-type: none"> 1. The humidifier drain is blocked 2. The supply water or overflow circuit has leaks 3. The condensate drain pipe does not bring the water back to the drain pan 4. The steam hose is not properly fastened to the cylinder 	<ol style="list-style-type: none"> 1. Clean the drain assembly and pan 2. Check the entire water circuit 3. Check the correct position of the condensate drain hose in the drain pan 4. Check the fastening of the hose clamps on the steam outlet

Tab. 6.a

Problem	Causes	Solutions
Water in the cylinder turns black	<ol style="list-style-type: none"> 1. Minerals in the cylinder have overconcentrated and are deteriorating the electrodes. 	<ol style="list-style-type: none"> 1. Check for sags & kinks that could trap condensate in the steam hoses that could cause a back pressure on the cylinder. 2. Check the duct static pressure. 3. Check the fill valve and inlet strainer. 4. Check the drain pump operation. 5. Correct installation problems and replace cylinder.
Heavy arcing occurs within hours of startup	<ol style="list-style-type: none"> 1. The feed water contains large amounts of Iron, Copper or other conductive contaminants. 	<ol style="list-style-type: none"> 1. Contact the factory for an optional drain timer to force additional drains to control the minerals. 2. If you are using a softener. Discontinue use. 3. Check the electrodes in the cylinder to be sure they were not damaged in shipping.
Humidifier continuously fills and drains without producing steam	<ol style="list-style-type: none"> 1. Mineral has bridged between the electrodes. 2. There is back pressure from the steam hoses or duct. 3. The flow regulator in the fill valve is broken or out of place. 4. Water conductivity is very high. 5. Water is foaming excessively. 	<ol style="list-style-type: none"> 1. Clean or replace the cylinder. 2. Check the steam hoses for kinks or gullies that might be trapping condensate. 3. Replace the fill valve. 4. Consider using a mix of demineralized water with raw water. 5. Check cylinder - replace if exhausted. If feed water contains silica or nitrates, install a 1 micron water filter.

Tab. 6.b

7. MAINTENANCE

7.1 Periodic checks

- After one hour of operation: Check that there are no significant water leaks.
- Every fifteen days or no more than 300 operating hours: Check operation, that there are no significant water leaks and the general condition of the cylinder. Check that during operation there is no arcing between the electrodes.
- Every three months or no more than 1000 operating hours: Check operation, that there are no significant water leaks and, if necessary, replace the cylinder. Check that there are no blackened parts of the cylinder. If there are blackened parts of the cylinder, check the condition of the electrodes, and if necessary replace the cylinder.
- Annually or no more than 2500 operating hours: Replace the cylinder.

CAUTION: ALWAYS DISCONNECT THE MAIN POWER BEFORE DOING MAINTENANCE!

CAUTION: always disconnect the main power before touching the cylinder in the event of leaks, as current may flow through the water.

7.2 Cylinder maintenance

The life of the cylinder depends on a number of factors, including: the amount and type of mineral in the water, the correct use and sizing of the humidifier, and the output, as well as careful and regular maintenance. Another factor affecting cylinder life is Maximum Production, the higher the production rate the shorter the cylinder life; for this reason the DS-25 and RS-25 are preset from the factory at 70%. Further reductions in maximum production will extend cylinder life. See figure 7.a

IMPORTANT WARNINGS

The humidifier and its cylinder contain live electrical components and hot surfaces, and therefore all service and/or maintenance operations must be performed by expert and qualified personnel, who are aware of the necessary precautions. Before performing any operations on the cylinder, check that the humidifier is disconnected from the power supply. Remove the cylinder from the humidifier only after having drained it completely using the manual “drain” button or procedure. Check that the model and the power supply voltage of the new cylinder correspond to the data on the rating label.

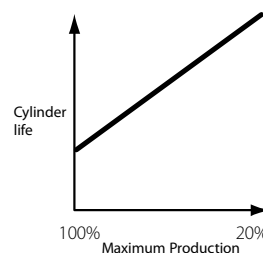

Fig. 7.a

7.2.1 Replacing the cylinder

IMPORTANT WARNING: the cylinder may be hot. Allow it to cool before touching it or use protective gloves.

To replace the cylinder:

1. Completely drain the cylinder by pressing and holding the “**drain**” button until the cylinder is empty;
2. Turn the humidifier off and disconnect the main power;
3. Remove the cover;
4. DS Models:
 - Remove the steam hose from the cylinder;
 - Flip up the cylinder holding bracket and lift the cylinder out of the unit;
5. RS Models:
 - Undo the 2 bolts of the embedded fan;
 - Flip up the cylinder holding bracket;
6. Disconnect the distributor from the cylinder and lift the cylinder out of the unit;
7. Disconnect the electrical connections from the top of the cylinder;
8. Install the new cylinder in the humidifier by performing the previous operations in reverse

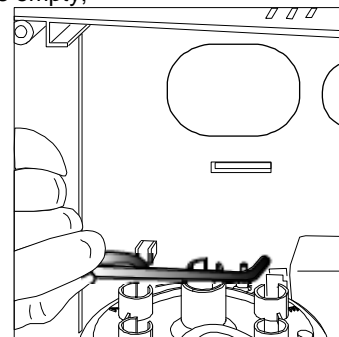

Fig. 7.b

CAUTION: Do not tighten the 7/8” hose clamp so tight that it crushes the cylinder outlet

WARNING: Electrical connections to the cylinder must be tight or possible fire hazard may result.

Threaded nuts on power wires must be connected with 22 to 29 inch-pounds of torque (2.5 to 3.3 Nm).

7.2.2 Maintenance of the other plumbing components

IMPORTANT WARNINGS:

- External power must always be disconnected when performing any maintenance on the humidifier.
- When cleaning the plastic components do not use detergents or solvents;
- Scale can be removed using a solution by using vinegar or a weak solution of acetic acid and a soft brush; then rinse the cylinder thoroughly with fresh water.

Cleaning the fill valve:

After having disconnected the cables and the hoses, remove the valve and check the condition of the inlet filter; clean if necessary using the same cleaning solution as for the steam cylinder and a soft brush.

Cleaning the drain pump:

Remove the valve body, clean if necessary using the same cleaning solution as for the steam cylinder and a soft brush.

Cleaning the drain pan:

Clean the pan of any mineral deposits and check that the water flows freely from the pan to the drain at the drain pump.

Cleaning the supply, fill, overflow pipes: Check that these are clear and clean or replace if necessary.

IMPORTANT WARNING: after having replaced or checked the plumbing, check that components have been reconnected correctly with the proper seals. Re-start the humidifier and perform a number of cleaning cycles (from 2 to 4, read chap. “Starting with a new cylinder”), then check for any water leaks.

7.3 Replacement Parts

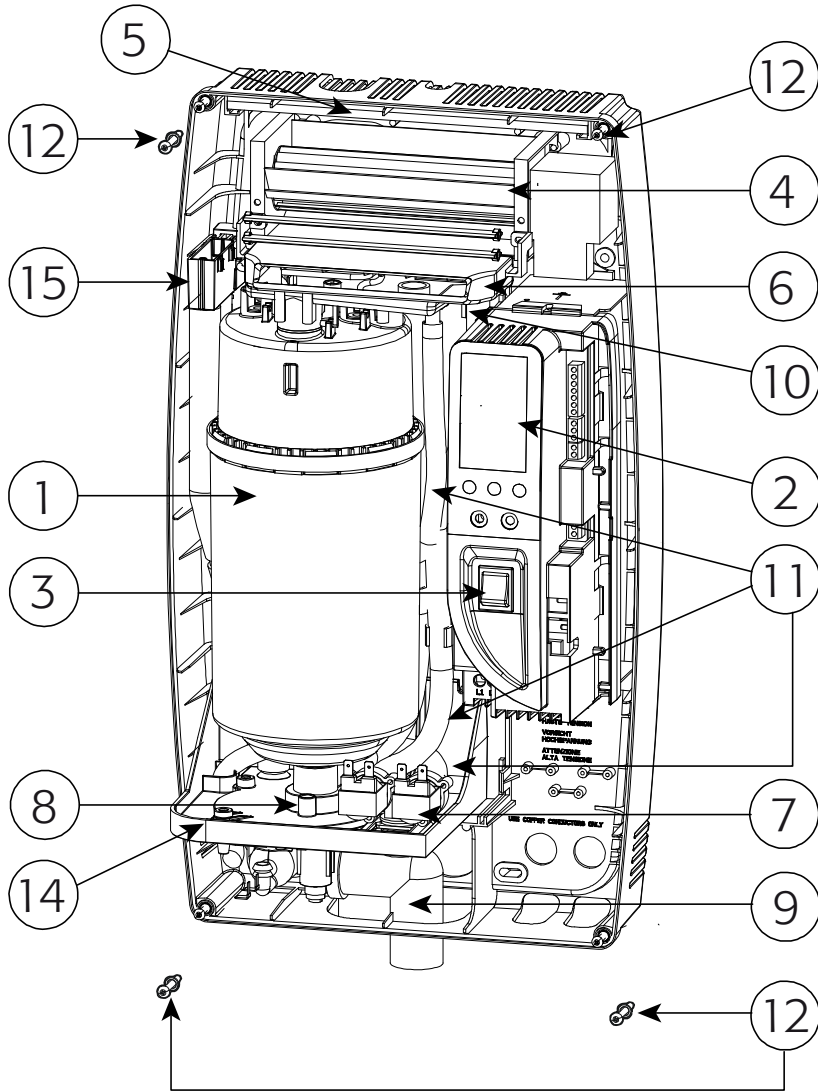

Item	Part No.	Description
1	See the table below	Steam generator cylinder
2	7800	25-1 CONTROL MODULE 5.4 kg/h 230V WITH DRAIN PUMP
	7801	15-5 CONTROL MODULE 2.5 kg/h 110V WITHN DRAIN PUMP
3	7551	35-18 ON/OFF SWITCH FOR CH SERIES
4	7534	15-2 ROOM BLOWER ASSEMBLY 110/1 FOR CH SERIES
	7535	35-2 ROOM BLOWER ASSEMBLY 230/1 FOR CH SERIES
5	7544	35-19 BLOWER FILTER KIT FOR CH SERIES
6	7536	35-20 INTERNAL STEAM DISTRIBUTOR MANIFOLD FOR CH SERIES
7	7802	15-6 FILL SOLENOID VALVE + DRAIN TEMPERING 110 V FOR DRAIN PUMP
	7803	25-3 FILL SOLENOID VALVE + DRAIN TEMPERING 230 V FOR DRAIN PUMP
8	7804	15-7 KIT FOR DRAIN PUMP 110V
	7805	25-7 KIT FOR DRAIN PUMP 230V
9	7542	35-21 90 DEGREE DRAIN ADAPTER FOR CH SERIES
10	7806	25-2 FILL TANK + PLUG FOR DRAIN PUMP
11	7807	25-4 ROOM TUBING KIT FOR DRAIN PUMP
	7808	25-5 DUCT TUBING KIT FOR DRAIN PUMP
12	7553	35-25 COVER HOLDING SCREWS FOR CH SERIES
14	7809	25-6 BOTTOM TANK FOR DRAIN PUMP
15	7810	25-8 DRAIN TANK + PLUG FOR DRAIN PUMP
	7811	25-50 WIRING KIT FOR UNIT WITH DRAIN PUMP

Item	Part No.	Description
1	7523	15-14 CYLINDER STD. CONDUCTIVITY 110/1 5.5 LBS/HR DS15P, RS15P, DS15, RS15
1	7524	35-14 CYLINDER STD. CONDUCTIVITY 230/1 12 LBS/HR DS25, RS25, DS25LC, RS25LC
1	7543	35-15 CYLINDER LOW CONDUCTIVITY 230/1 12 LBS/HR DS25, RS25, DS25LC, RS25LC
1	7516	20-14A CYLINDER STD. CONDUCTIVITY 230/1 7 LBS/HR DS20A, RS20A
	7552	35-16 INTERNAL FILTER AND GASKET KIT FOR CYLINDER

8. TECHNICAL SPECIFICATIONS

Steam flows, VAC, kW	5.5 lbs/hr (2.5 kg/h): 110 VAC 1-phase 50-60 Hz, 1.86 kW 12 lbs/hr (5.4 kg/h): 230 VAC 1-phase 50-60 Hz, 4.05 kW	Notes
Steam pressure	3.81 in WC / 950 Pa	For duct only
Dimensions (mm)	24" x 14" x 8" (600 x 341 x 204 mm)	(Height x Width x Depth)
Weight empty/packaged/installed with water	18/22/26 lbs. (8/10/12 kg)	
IP class	IP20	
Electrode power cables	12 AWG	
Power relays	2 x 30 Amp	on board
Ground connection	Screw	
Input water type	Potable water	no demin. or softened water
Conductivity range	125-1250 µS/cm	Special cylinders for cond. < 350
Water fill connection	1/4" O.D. Compression	Adapter to 3/4" FPS
Water fill - instant flow	0.09 – 0.16 gpm (0.35 – 0.60 l/min)	
Drain connection	32 mm O.D. (1.25")	Adjustable from horizontal to vertical. May be from back or bottom of unit.
Drain water temp	< 140°F (< 60°C)	drain tempering device
Drain flow	Max 7.1 gpm (max 26.8 l/min)	
Embedded fan flow	71 cfm (120 m³/hr)	Direct Room Discharge Only
Serial communication	RS485	

9. LIMITED WARRANTY

DS and RS Residential Humidifiers, if properly registered by the return of the page 25 warranty registration to General Filters, Inc., are warranted to the consumer against defects in materials and workmanship for a period of two years from the date of installation, so long as the product has been installed and operated in accordance with all appropriate manuals and wiring diagrams in a residential structure.

Installation in commercial, industrial or office building will void all warranties. Installation to a water source that does not meet unit specification will void all warranties. Replacement of routinely replaceable parts such as steam cylinders and gaskets, are not covered by this limited warranty or any other warranties.

Any other defective parts will be repaired without charge except for removal, reinstallation and transportation costs. To obtain repair service under this limited warranty, the consumer must send the defective part to General Filters, Inc.

THERE ARE NO EXPRESS WARRANTIES COVERING THIS HUMIDIFIER OTHER THAN AS SET FORTH ABOVE. THE IMPLIED WARRANTIES OF MERCHANTABILITY AND FITNESS FOR A PARTICULAR PURPOSE ARE EXPRESSLY EXCLUDED. THE MANUFACTURER ASSUMES NO LIABILITY IN CONNECTION WITH THE INSTALLATION OR USE OF THIS PRODUCT, EXCEPT AS STATED IN THE LIMITED WARRANTY. THE MANUFACTURER WILL IN NO EVENT BE LIABLE FOR INCIDENTAL OR CONSEQUENTIAL DAMAGES. This limited warranty gives you specific legal rights, and you may also have other rights which vary from state to state. Some states do not allow either limitations on implied warranties, or exclusions from incidental or consequential damages, so the above exclusion and limitation may not apply to you.

Any questions pertaining to this limited warranty should be addressed to General Filters, Inc. General Filters, Inc. has elected not to make available the informal dispute settlement mechanism which is specified in the Magnuson-Moss Warranty Act.

General Filters, Inc.
43800 Grand River
Novi, MI 48375-1115
www.generalfilters.com

Canadian General Filters, Inc.
400 Midwst Road
Scarborough, ON M1P 3A9
www.cgfproducts.com

 <p>FILL OUT AND MAIL THIS WARRANTY CARD AND LITERATURE REQUEST FORM</p> <p><input type="checkbox"/> AIR CLEANERS AND AIR PURIFIERS</p> <p><input type="checkbox"/> HUMIDIFIERS</p> <p><input type="checkbox"/> DIGITAL HUMIDITY GAGE</p> <p><input type="checkbox"/> AIR FILTER GAGE</p> <p><input type="checkbox"/> FUEL OIL FILTERS AND ACCESSORIES</p>	<p style="text-align: right;">OWNER REGISTRATION ONLINE AT WWW.GENERALAIRE.COM OR FILL IN REGISTRATION AND MAIL TO:</p> <p style="text-align: right;">WARRANTY REGISTRATION</p> <p style="text-align: right;">GENERAL FILTERS, INC. 43800 GRAND RIVER AVE NOVI, MI 48375-1115</p> <p>MODEL _____ SERIAL # _____</p> <p>OWNER'S NAME _____</p> <p>STREET ADDRESS _____ STATE _____</p> <p>CITY _____ PROVINCE: _____ POSTAL CODE _____</p> <p>DEALER'S NAME _____</p> <p>STREET ADDRESS _____ STATE _____</p> <p>CITY _____ PROVINCE: _____ POSTAL CODE _____</p> <p>DATE OF INSTALLATION _____</p>
--	--



GENERAL FILTERS, INC.
43800 GRAND RIVER AVE
NOVI, MICHIGAN 43875-1115

WWW.GENERALAIRE.COM

CANADIAN GENERAL FILTERS, LTD.
400 MIDWEST POAD
SCARBOROUGH, ONTARIO M1P3A9

WWW.CGFPRODUCTS.COM

Agency: