

# Forbes Marshall Safety Relief Valve

---

FMSRV (DN 15)

---

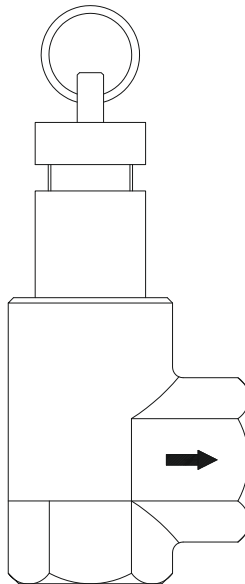

**ProductHUB**

Installation and Maintenance Guide



## Table of Contents

1.	Preface .....	1
2.	Important Safety Notes .....	1
3.	Brief Product Information .....	3
4.	Product Working Principle .....	6
5.	Installation Guidelines .....	6
6.	Startup and Commissioning.....	7
7.	Maintenance Guidelines .....	8
8.	Troubleshooting .....	9
9.	Available Spares .....	9
10.	Warranty Period .....	9

**PLEASE NOTE** - Throughout this manual this cautionary symbol is used to describe a potential damage or injury that might occur if the safety considerations are overlooked. This symbol denotes CAUTION, WARNING or DANGER.



## 1. Preface:

This manual is intended for anyone using, commissioning, servicing, or disposing of the below mentioned products safely and efficiently.

### **Forbes Marshall Safety Relief Valve. [FMSRV (DN15)]**

**Sizes:** DN15 (1/2")

#### **PLEASE NOTE:**

Throughout this manual the following cautionary symbol is used to describe a potential damage or injury that might occur if the safety considerations are overlooked.

## 2. Important Safety Notes:



Read this section carefully before installing/operating/maintaining the product. The precautions listed in this manual are provided for personnel and equipment safety. Furthermore, Forbes Marshall accepts no responsibility for accidents or damage occurring as a result of failure to observe these precautions. Note that the product is designed to perform for non-contaminated fluids only. A contamination in the form of chemical, foreign particle etc. can lead to problem with product performance and life of the product.

If these products in compliance with the operating instructions are, properly installed, commissioned, maintained and installed by qualified personnel (refer Section 2.7) the safety operations of these products can be guaranteed. General instructions for proper use of tools and safety of equipments, pipeline and plant construction must also be complied with.

### **2.1 Intended use:**

Check if the product is suitable for intended use/ application by referring to the installation and maintenance instructions, name plates and technical information sheets.

- i) The product is suitable for use as defined in the technical information sheet. In case the need arises to use the product on any other fluid please contact Forbes Marshall for assistance.
- ii) Check for the suitability in conformance to the limiting conditions specified in technical information sheet of the product.
- iii) The correct installation and direction of fluid flow has to be determined.
- iv) Forbes Marshall products are not intended to resist external stresses, hence necessary precautions to be taken to minimize the same.

### **2.2 Accessibility and Lighting:**

Safe accessibility and working conditions are to be ensured prior to working on the product.

### **2.3 Hazardous environment and media:**

The product has to be protected from hazardous environment and check to ensure that no hazardous liquids or gases pass through the product.

### **2.4 Depressurizing of systems and normalizing of temperature:**

Ensure isolation and safety venting of any pressure to the atmospheric pressure. Even if the pressure gauge indicates zero, do not make an assumption that the system has been depressurized.

To avoid danger of burns allow temperature to normalize after isolation.

### **2.5 Tools and consumables:**

Ensure you have appropriate tools and / or consumables available before starting the work. Use of original Forbes Marshall replacement parts is recommended.

### **2.6 Protective clothing:**

Consider for the requirement of any protective clothing for you/ or others in the vicinity for protection against hazards of temperature (high or low), chemicals, radiation, dangers to eyes and face, noise and falling objects

### **2.7 Permits to work:**

All work to be carried out under supervision of a competent person. Training should be imparted to operating personnel on correct usage of product as per Installation and Maintenance instruction. "Permit to work" to be complied with (wherever applicable), in case of absence of this system a responsible person should have complete information and knowledge on what work is going on and where required, arrange to have an assistant with his primary goal and responsibility being safety. "Warning Notices" should be posted wherever necessary.

### **2.8 Handling:**

There is a risk of injury if heavy products are handled manually. Analyze the risk and use appropriate handling method by taking into consideration the task, individual, the working environment and the load.

### **2.9 Freezing:**

Provision should be made to protect systems which are not self-draining, against frost damage (in environment where they may be exposed to temperatures below freezing point) to be made.

### **2.10 Returning products:**

Customers and Stockist are reminded that, when returning products to Forbes Marshall they must provide information on any hazards and the precautions to be taken due to contamination residues or mechanical damage which may present a health, safety or environmental risk.

This information must be provided in writing including Health and Safety data sheets relating to any substances identified as hazardous or potentially hazardous.

### 3. Brief Product Information:

#### 3.1 Description:

The Forbes Marshall Safety Relief Valve FMSRV is a high lift safety valve with gun metal seat, valve and body and brass internals suitable for use on steam, air and water.

#### 3.2 Size and Pipe Connections:

DN 15

Screwed BSPT

**Note** : Available with IBR certificate

**For following set pressure ranges 5 colour coded springs are available**

00 to 15 psi	White
15 to 35 psi	Yellow
35 to 75 psi	Green
75 to 125 psi	Blue
125 to 250 psi	Red

#### 3.3 Limiting Conditions:

Minimum blow off pressure	0.34 bar g
Maximum blow off pressure	17.3 bar g

#### 3.4 Operating Range:

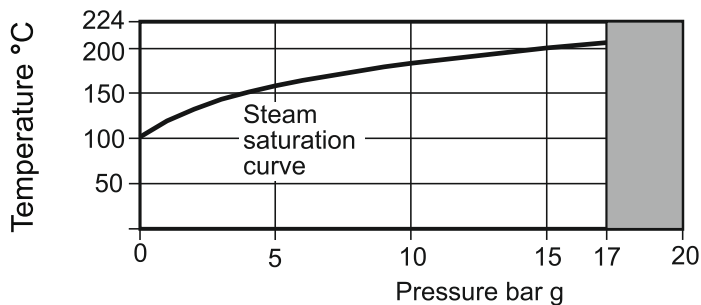

 The product **must not** be used in this region.

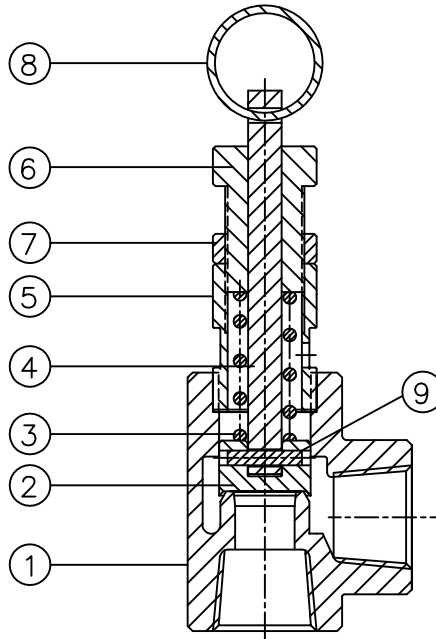
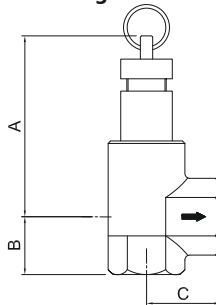

**Figure 1: Forbes Marshall Safety Relief Valve**

**Materials:**

Sr. No.	Part	Material	Standard
1	Body	G.M	BS 1400
2	Valve Head	G.M.	BS 1440 LG 2
3	Spring	Spring Steel	I.S. 4454 part IV
4	Spindle	Brass	I.S.4170
5	Bonnet	Brass	I.S.4170
6	Adjustment Cap	Brass	I.S.4170
7	Lock Nut	Brass	I.S.4170
8	Ring	C 20	I.S.2062
9	Dowel Pin	SS 304	ASTM A 276

### 3.5 Product Dimension and Drawing:



**Figure 2: Dimensional drawing of FMSRV (DN15)**

Dimensions: (approx. ) in mm:

Size (DN)	A	B	C	Weight (kg)
15	87	23	30	0.42

### 3.6 Capacity Chart:

Discharge capacities with 10% accumulation above the set pressure for various fluids shown below

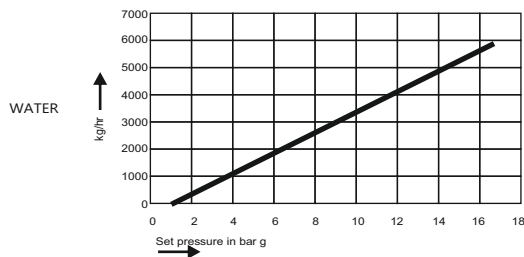
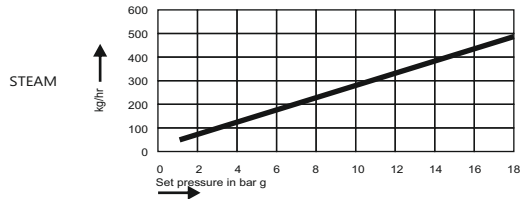

#### 4. Product Working Principle (Refer to Figure 1):

The Forbes Marshall Safety Relief Valve is normally set at a pressure which is 10% above the working pressure of the system. This is referred to as a set pressure. When the safety pressure reaches blow off pressure the safety valve opens to its full lift to discharge full capacity. The valve closes at reset pressure.

The steam enters the Safety Relief Valve through the inlet from the bottom. When the steam reaches the set point of the FMSRV it lifts the valve head **(2)** off the valve seat, working against the spring **(3)** present inside the valve body **(1)**. As long as the steam pressure exceeds the set pressure, the valve remains open. As soon as it comes below the set pressure, the spring force pushes the valve head **(2)** back onto the valve seat.

#### 5. Installation Guidelines (Refer to Figure 3):



**Note:** Before implementing any installations observe the "Important Safety notes" in section 2. Referring to the Installation and Maintenance Instructions, name-plate and Technical Information Sheet, check that the product is suitable for the intended installation.

1. The Forbes Marshall Safety Relief Valve should always be mounted vertically upwards with its main axis kept vertical.
2. There should be no intervening valve or any fitting between the piping and the safety relief valve which could isolate the FMSRV (Refer to fig. 3a).
3. The inlet connection should never be smaller than the valve inlet and output pipe should be either equal or larger than the valve outlet.
4. Where the outlet pipework is directed upwards a small bore drain should be provided at the lowest point. Take the drain to a place where discharge will not create any hazard or inconvenience (Refer to fig. 3b).
5. Each safety relief valve should have its own discharge pipe.
6. Make sure that safety relief valve is set to the correct pressure.
7. Safety relief Valves should not be insulated.
8. Excessive pressure loss at the inlet of a safety relief valve when it operates will cause extremely rapid opening and closing of the valve, observed as chattering or hammering. This may result in reduced capacity as well as damage to seating faces and the other parts of the valve. When normal pressure is restored it is possible that the valve will leak. Therefore the Valve should be fitted 8-10 pipe diameters downstream of Converging or Diverging Fittings or Bends (Refer to fig. 3c)



These valves are not suitable for mounting on boilers

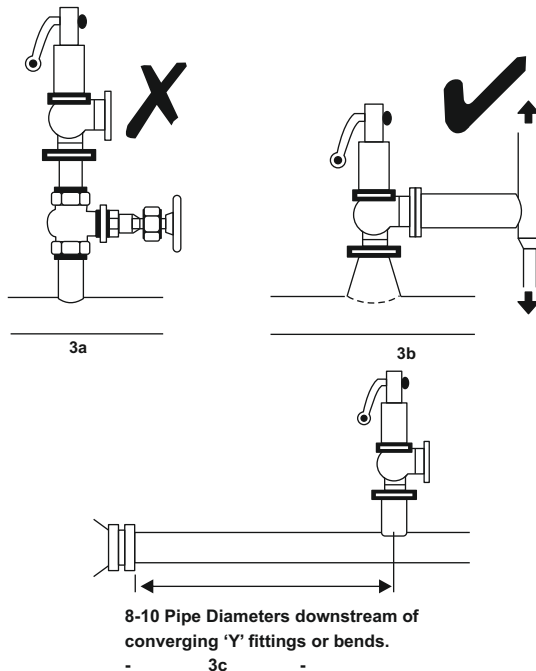

**Figure 3: Correct Installation of Safety Valve**

## 6. Startup and Commissioning :

### 6.1 Flushing of lines:

As part of pre-installation all fluid handling equipment particularly piping should be thoroughly cleaned of scale and the internal debris which accumulates during construction. This is accomplished by blowing or flushing with air, steam, water and other suitable medium.

Note: For a detailed procedure on flushing of lines please visit Forbes Marshall website.

### 6.2 Commissioning:

1. Fit the valve and ensure there is no leakage from the inlet or outlet connections. Raise the system pressure and check the valve working. Make sure that the valve operates at the correct pressure and the over pressure is only be limited to 10% of the system pressure.
2. Set the valve at the set pressure. If the valve is set too close to the operating pressure of the system the valve may operate continuously and keep on popping up. This may result in reduced capacity as well as damage to seating faces and the other parts of the valve. It will also fail to close satisfactorily when normal operating pressure is restored. Hence it is advisable to set it at 10% higher than the operating pressure.

## 7. Maintenance Guidelines :



Before undertaking any maintenance on the product it must be isolated from both supply line and return line and any pressure should be allowed to safely normalize to atmosphere. The product should then be allowed to cool.

### 7.1 Routine and Preventive Maintenance:

S.No	Parameters to be checked	Frequency for checking and maintaining						
		Immediately	Daily	weekly	Monthly	Quarterly	Half yearly	Annually
1	Visual inspection for leakages		Y					
2	Testing of Safety relief Valve					Y		
3	Cleaning of internals							Y

\*Re-certification by respective regulatory authorities as and when required

### 7.2 Tool Kit:

To carry out any maintenance of the SRV please use the tools mentioned in the table below.

Part	Tool	Size
Bonnet	open spanner	22mm (A/F)
Valve seat	box spanner	28 mm (A/F)
Adjust bolt and lock nut	open spanner	22mm (A/F)

### 7.3 Maintenance/Replacement Procedure : (Refer to Figure 1)

1. Before carrying out any maintenance on the valve, make sure that it is isolated first.
2. Remove the Safety Relief Valve from the pipeline.
3. Remove the adjustment bolt **(6)** and the adjustment nut **(7)**
4. Remove the bonnet **(5)** of the valve
5. Pull out the spindle **(4)** off the body **(1)** to expose the valve head **(2)** with the spring **(3)** out of the body.
6. Clean and lap the valve seat on the valve head in oscillation motion.
7. Reassemble in the reverse manner.
8. Fit the valve back on the pipeline. Set the pressure to 10% above the working pressure of the system. Use the adjustment bolt, nut and the pressure gauge present downstream to set the pressure.

## 8. Troubleshooting:

If the expected performance is unachievable after the installation of the safety relief valve, check the following points for appropriate corrective measures.

Failure Mode	Possible Cause	Remedy
Valve Leakage	Check for spring range	Refer to the spring ranges given in section 3.2
	Valve seating surface dirty or damaged	It is usually sufficient to clean the seating surfaces and reassemble. If the seating surface has been damaged it is necessary to re-lap. When reassembling all foreign matter and scales should always be cleared away from the surrounding components, all lapping paste removed and seating surface cleaned.
Not Releasing the Pressure	Check the pressure setting of the valve	<ol style="list-style-type: none"> <li>1. It should be 10% above the working pressure of the system.</li> <li>2. Make sure the spring range selected is not higher than mentioned in section 3.2 for a given pressure range.</li> </ol>

## 9. Available Spares:

SPARE CODE	SPARE PART
S2250520	SPARES KIT: DN15 VALVE HEAD AND SPINDLE KIT FOR FMSRV (DN 15) (STEAM &
S2250521	SPARES KIT: SPRING KIT FOR DN15 FMSRV (DN 15) - 05 - 15 – PSI
S2250522	SPARES KIT: SPRING KIT FOR DN15 FMSRV (DN 15) - 15 - 35 – PSI
S2250523	SPARES KIT: SPRING KIT FOR DN15 FMSRV (DN 15) - 35 - 75 – PSI
S2250524	SPARES KIT: SPRING KIT FOR DN15 FMSRV (DN 15) - 75 - 125 – PSI
S2250525	SPARES KIT: SPRING KIT FOR DN15 FMSRV (DN 15) - 125 - 250 – PSI
S2250529	SPARES KIT: DN15 VALVE HEAD AND SPINDLE KIT FOR FMSRV (DN 15) (AIR

### How to Order:

Example: Forbes Marshall Safety Valve, FMSRV , DN15 with BSPT ends & a set pressure of 6 bar g.

**Note :** available with IBR certificates

### How to Order Spares:

Always order spares by using the description given in the column headed available spares. For codes refer user manual.

## 10. Warranty Period:

As per the ordering information and agreement in the contract

ALL CONTENTS HEREIN ARE THE PROPERTY OF FORBES MARSHALL PRIVATE LIMITED ("FMPL") OR FORBES MARSHALL STEAM SYSTEMS PRIVATE LIMITED ("FMSSPL"), AS THE CASE MAY BE, AND HAVING PROTECTION UNDER THE INTELLECTUAL PROPERTY RIGHTS. ANY REPRODUCTION, DISTRIBUTION OR DISCLOSURE WITHOUT PRIOR WRITTEN PERMISSION IS PROHIBITED.  
The information in this document is subject to change without notice. FMPL or its Subsidiaries, Associates, Affiliates and Group Companies assume no responsibility for inaccuracies or omissions and specifically disclaim any liabilities, losses, or risks, personal or otherwise, incurred as a consequence, directly or indirectly, of the use or application of any of the contents of this document.