

STK672-040GEVB, STK672-050GEVB, STK672-060GEVB



ON Semiconductor®

<http://onsemi.com>

STK672 Series Evaluation Board User's Manual

Thick-Film Hybrid IC Unipolar
Constant-current Chopper (external
Excitation PWM) Circuit with Built-in
Microstepping Controller Stepping Motor
Driver (sine wave drive)

EVAL BOARD USER'S MANUAL



Figure 1. STK672 Series Evaluation Boards

This Evaluation Board User's Manual describes the set-up and use of the STK672 Series Evaluation Board for SANYO Semiconductor (An ON Semiconductor Company) Thick-Film Hybrid IC Unipolar Constant-Current Chopper Circuit with Built-in Microstepping Controller Stepping Motor Driver devices STK672-040-E, STK672-050-E, and STK672-060-E. For datasheets and additional information on these devices, please visit the ON Semiconductor website at www.onsemi.com

STK672-040GEVB, STK672-050GEVB, STK672-060GEVB

EVALUATION BOARD

STK672-040-E and STK672-060-E (100.0 mm x 80.0 mm x 1.6 mm, phenol 1-layer board)

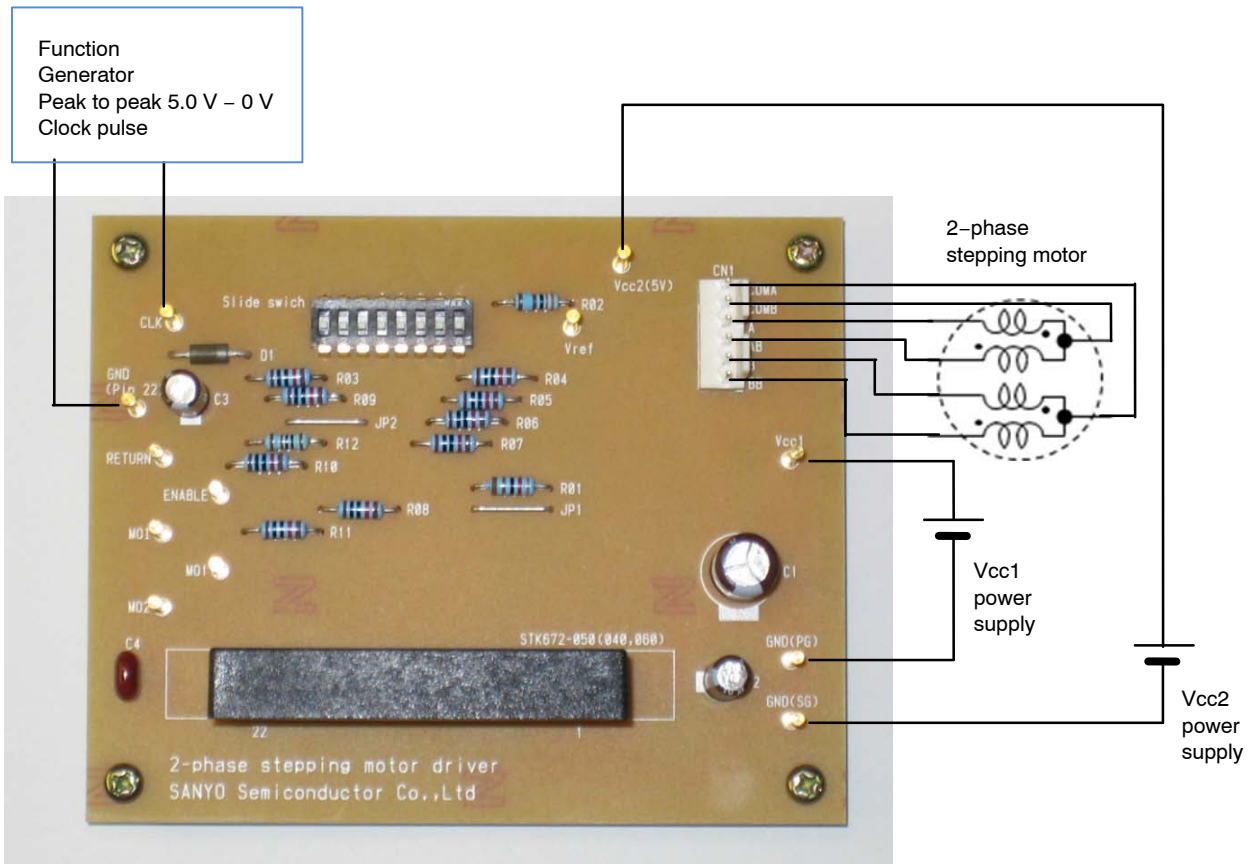

Figure 2. STK672-040-E / STK672-060-E Evaluation Board

STK672-040GEVB, STK672-050GEVB, STK672-060GEVB

EVALUATION BOARD

STK672-050-E(100.0 mm x 80.0 mm x 1.6 mm, phenol 1-layer board)

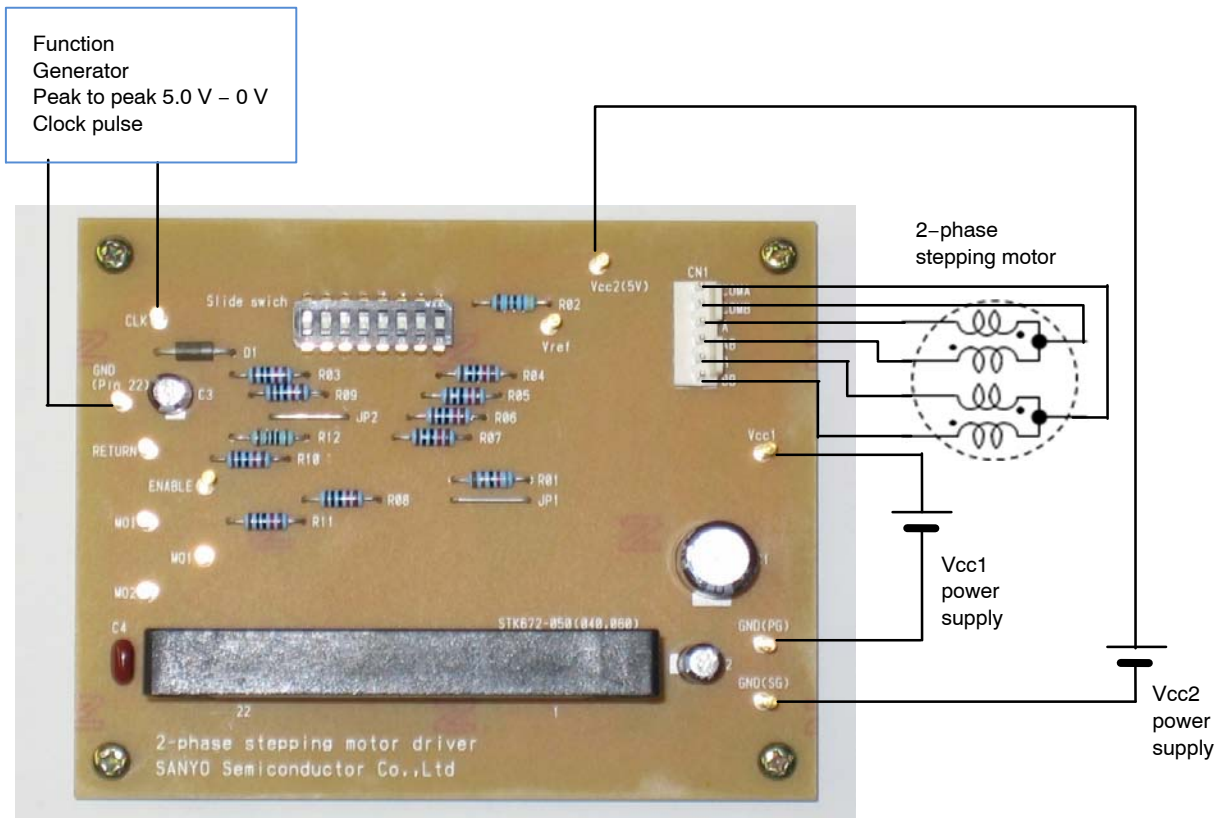
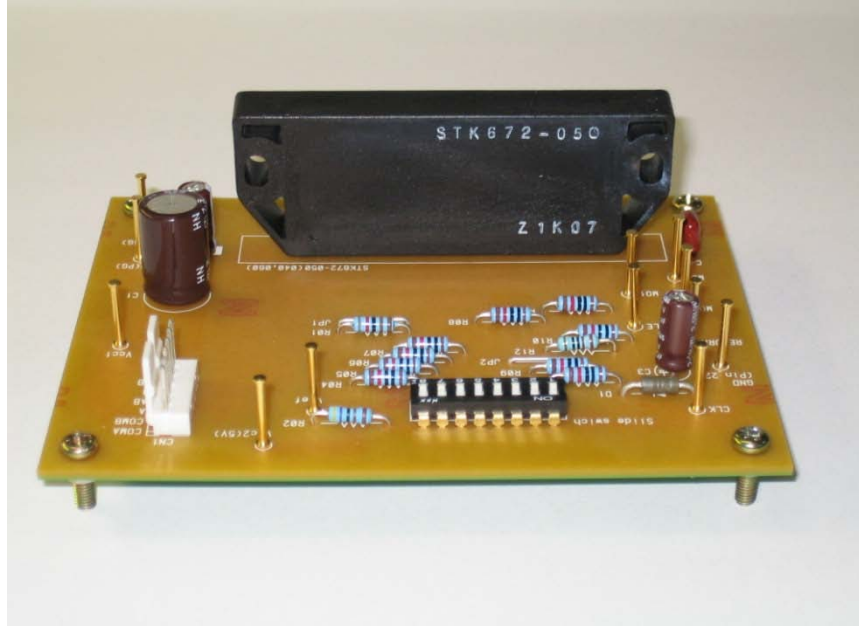

Figure 3. STK672-050-E Evaluation Board

STK672-040GEVB, STK672-050GEVB, STK672-060GEVB

SUBSTRATE SPECIFICATIONS

(Substrate recommended for operation of STK672-050-E)

Size: 100 mm x 80 mm x 1.6 mm 1-layer board

Material: Phenol

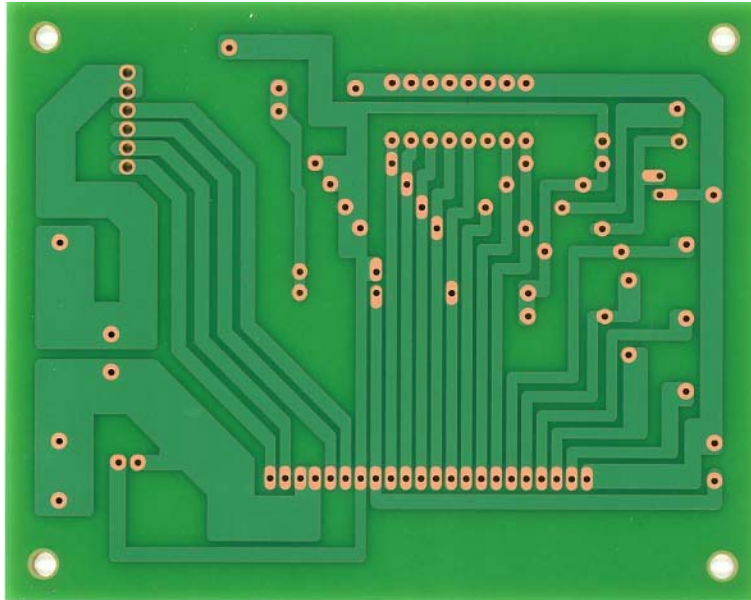

Figure 4. Copper Side (35 μ)

ALLOWABLE POWER DISSIPATION (Reference value)

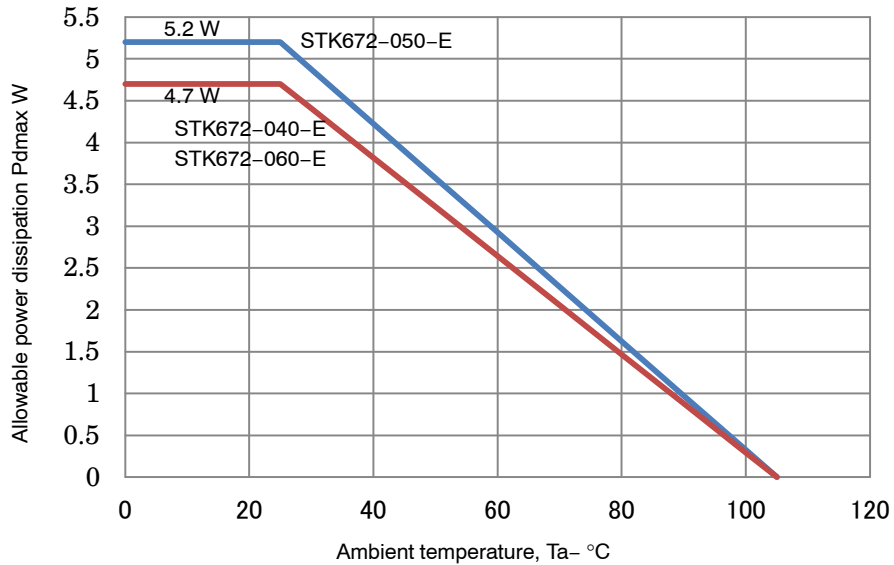

Figure 5. Allowable Power Dissipation

EVALUATION CIRCUIT

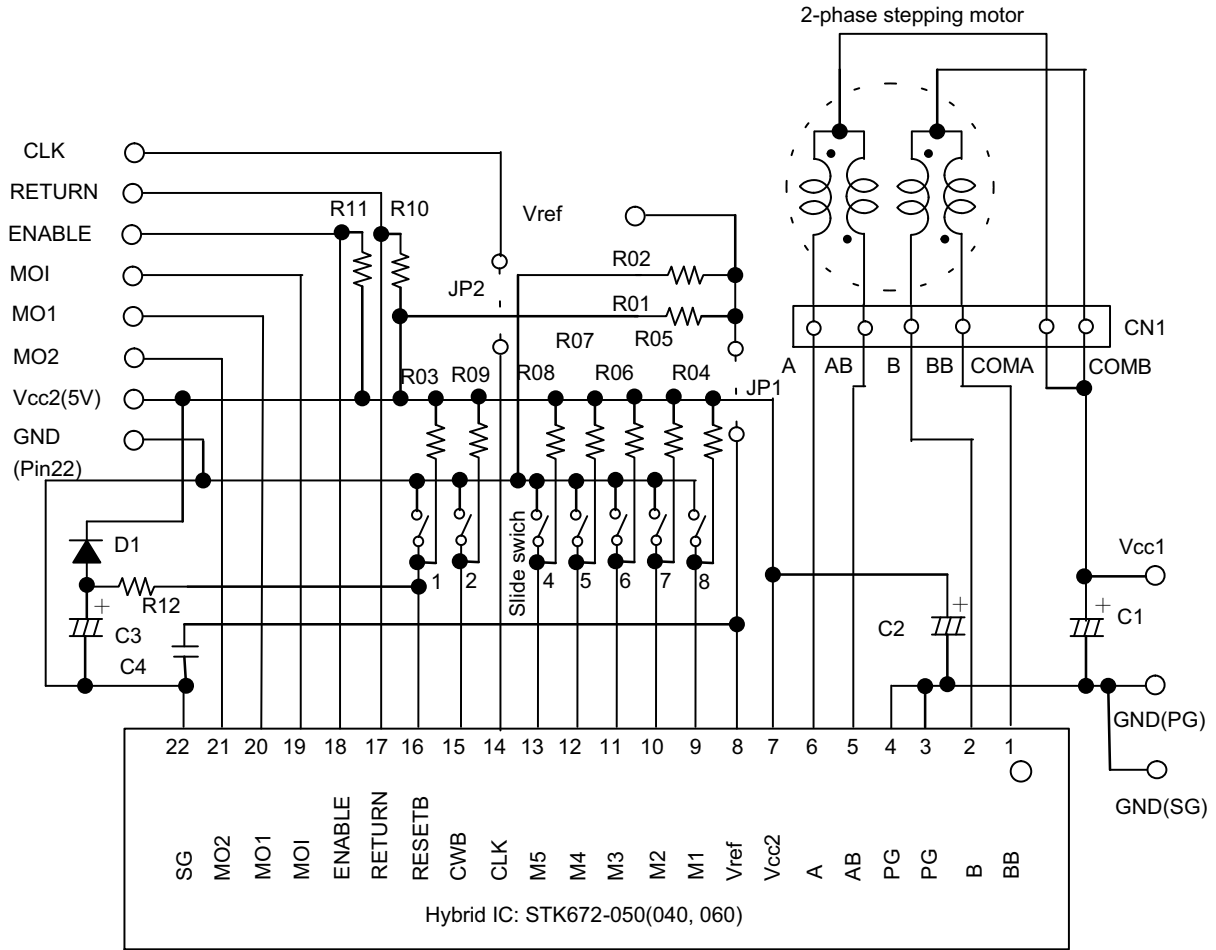

Figure 6. Evaluation Circuit

STK672-040GEVB, STK672-050GEVB, STK672-060GEVB

BILL OF MATERIALS

Table 1. BILL OF MATERIALS FOR STK672-050-E EVALUATION BOARD

Designator	QTY	Description	Value	Tolerance	Foot-print	Manufacturer	Manufacturer Part Number	Substitution Allowed	Lead Free
C1	1	Vcc1 Bypass Capacitor	220 μ F / 50 V	\pm 20%		SUN ELECTRONICS	50ME220CA	YES	YES
C2	1	Vcc2 Bypass Capacitor	10 μ F / 50 V	\pm 20%		SUN ELECTRONICS	50ME10CA	YES	YES
C3	1	Capacitor for power on reset circuit	10 μ F / 50 V	\pm 20%		SUN ELECTRONICS	50ME10CA	YES	YES
C4	1	Vref stabilization Capacitor	0.1 μ F / 50 V	\pm 10%		Panasonic	ECQV1H104JL2	YES	YES
R01	1	Resistor to set Vref		\pm 1%		AKAHANE ELECTRONICS	RN14S****FK	YES	YES
R02	1	Resistor to set Vref		\pm 1%		AKAHANE ELECTRONICS	RN14S****FK	YES	YES
R03 to R11	9	Pull-up Resistor	10 k Ω	\pm 5%		AKAHANE ELECTRONICS	RN14S103JK	YES	YES
R12	1	Resistor for power on reset circuit	1 k Ω	\pm 5%		AKAHANE ELECTRONICS	RN14S102JK	YES	YES
D1	1	Diode for power on reset circuit				SANYO Semiconductor (An ON Semiconductor Company)	DS135AE	YES	YES
HIC	1	Hybrid IC				SANYO Semiconductor (An ON Semiconductor Company)	STK672-050	NO	YES
CN1	1	Vertical Header				MOLEX	5045-06A	YES	YES
Slide switch	1	Dip slide switch				NIHON KAIHEIKI	JS01-08AP4-ST	YES	YES
JP1, JP2	2	Jumper				Mac-Eight	JR-4	YES	YES
TP1 to TP12	12	Test Point				Mac-Eight	ST-1-3	YES	YES

NOTE: R01 and R02 are used to Vref for current setting.
Therefore their value is not mentioned in this table.

STK672-040GEVB, STK672-050GEVB, STK672-060GEVB

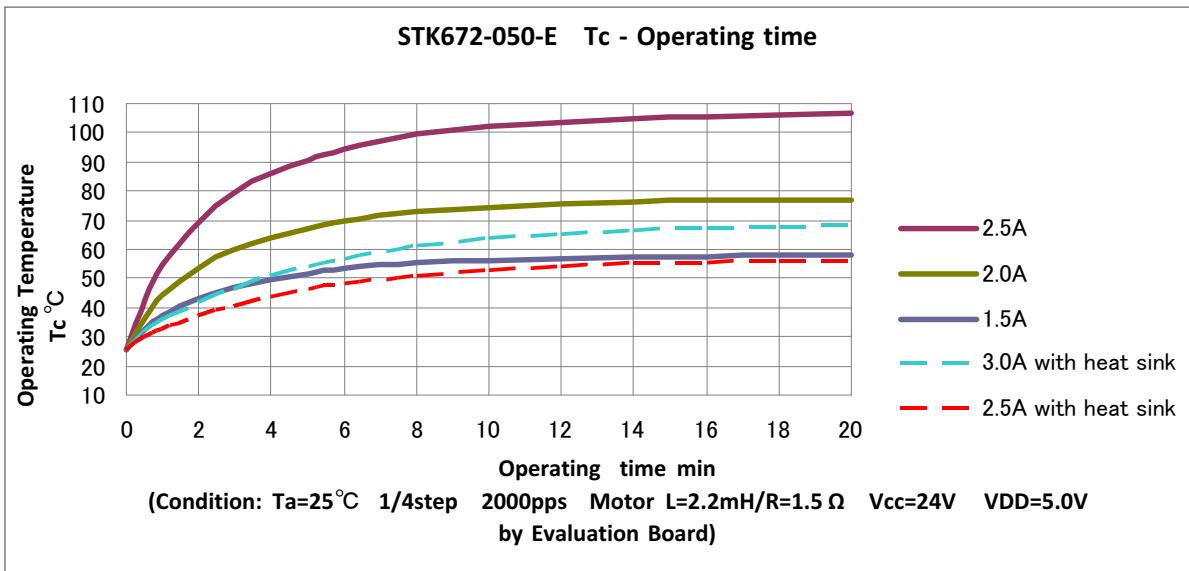
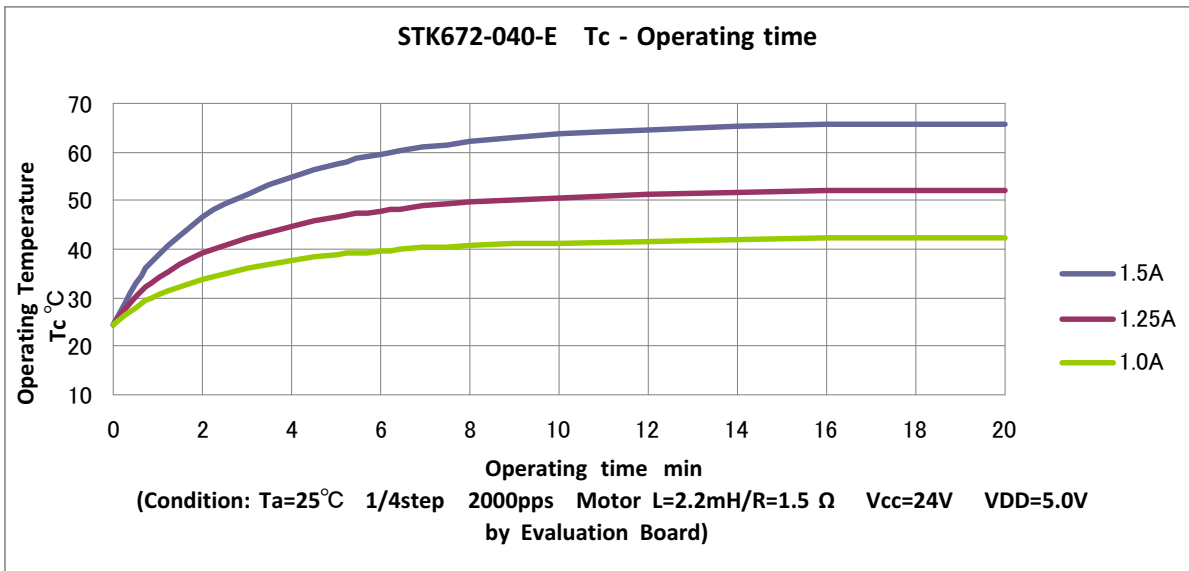
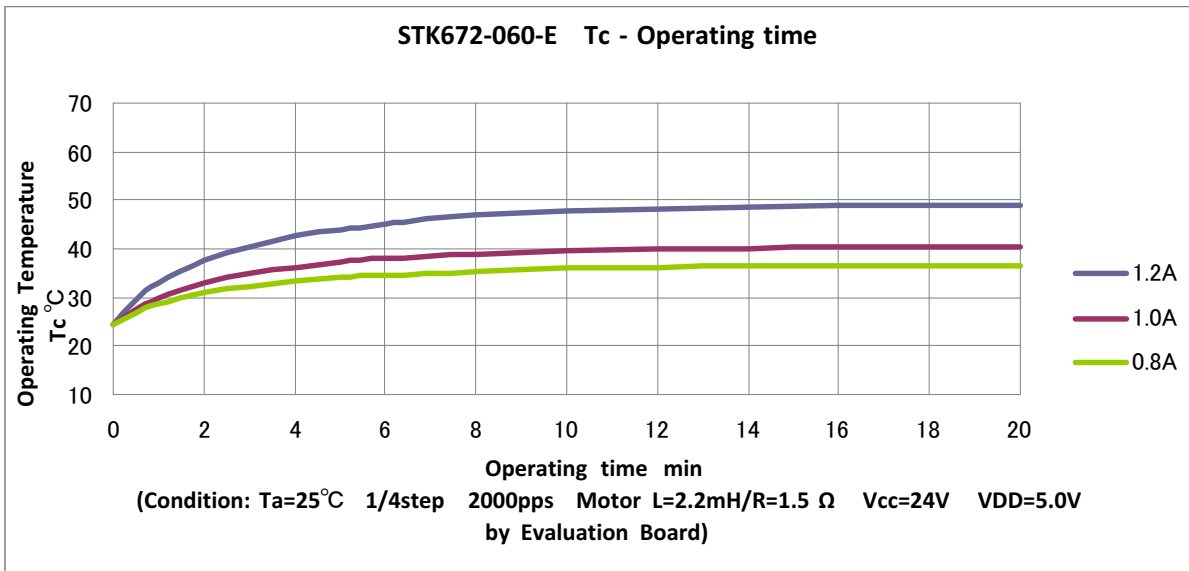

Figure 7. Operating Temperature

STK672-040GEVB, STK672-050GEVB, STK672-060GEVB

NOTES: Heat sink size used in STK672-050-E
IOH = 3.0 A and 2.5 A: 100 mm X 70 mm X
2.0 mm Al plate (no surface finish)
The Tc temperature should be checked in the
center of the metal surface of the product
package.

EVALUATION BOARD SETUP

[Supply Voltage]

Vcc1 (10 to 45 V): Power Supply for stepping motor
Vref (0 to 2.5 V): Const. Current Control for Reference
Voltage
Vcc2 (5 V): Power Supply for internal logic IC

[Toggle Switch State]

ON Side: Low (GND)
OFF Side: High (5 V pull up resistors)

[Operation Guide]

1. Motor Connection:
Connect the stepping motor to A, AB, B, BB,
COMA, and COMB.
2. Initial Condition Setting:
Set "ON" the slide switch RESETB, and set "ON
or OFF" M1 to M5 depend on step mode, and set
"ON or OFF" CWB, and set low CLK.
3. Power Supply:
At first, supply DC voltage to Vcc2, and VREF.
Next, supply DC voltage to Vcc1.
4. Ready for Operation from Standby State:
Turn "OFF" the slide switch RESETB.
Output A and BB are set initial position 70%.
5. Motor Operation:
Input the CLK signal into the terminal CLK.

[Setting the motor current]

The motor current IOH is set by the Vref voltage on the
hybrid IC pin 8. The following formula gives the
relationship between IOH and Vref.

STK672-040-E

$IOH = (1/3) \times Vref / R_s$, R_s : The hybrid IC internal current
detection resistor (0.33 Ω 3%)
 $Vref = Vcc2 (5.0 V) \times R02 / (R01 + R02) = IOH \times R_s \times 3$
In case of IOH = 1.2 A, Vref = 1.2 x 0.33 x 3 = 1.19 V

STK672-050-E

$IOH = (1/3) \times Vref / R_s$, R_s : The hybrid IC internal current
detection resistor (0.2 Ω 3%)
 $Vref = Vcc2 (5.0 V) \times R02 / (R01 + R02) = IOH \times R_s \times 3$
In case of IOH = 2.0 A, Vref = 2.0 x 0.2 x 3 = 1.2 V

STK672-060-E

$IOH = (1/7.66) \times Vref / R_s$, R_s : The hybrid IC internal current
detection resistor (0.22 Ω 3%)
 $Vref = Vcc2 (5.0 V) \times R02 / (R01 + R02) = IOH \times R_s \times 7.66$
In case of IOH = 0.8 A, Vref = 0.8 x 0.22 x 7.66 = 1.35 V

ON Semiconductor and  are registered trademarks of Semiconductor Components Industries, LLC (SCILLC). SCILLC reserves the right to make changes without further notice to any products herein. SCILLC makes no warranty, representation or guarantee regarding the suitability of its products for any particular purpose, nor does SCILLC assume any liability arising out of the application or use of any product or circuit, and specifically disclaims any and all liability, including without limitation special, consequential or incidental damages. "Typical" parameters which may be provided in SCILLC data sheets and/or specifications can and do vary in different applications and actual performance may vary over time. All operating parameters, including "Typicals" must be validated for each customer application by customer's technical experts. SCILLC does not convey any license under its patent rights nor the rights of others. SCILLC products are not designed, intended, or authorized for use as components in systems intended for surgical implant into the body, or other applications intended to support or sustain life, or for any other application in which the failure of the SCILLC product could create a situation where personal injury or death may occur. Should Buyer purchase or use SCILLC products for any such unintended or unauthorized application, Buyer shall indemnify and hold SCILLC and its officers, employees, subsidiaries, affiliates, and distributors harmless against all claims, costs, damages, and expenses, and reasonable attorney fees arising out of, directly or indirectly, any claim of personal injury or death associated with such unintended or unauthorized use, even if such claim alleges that SCILLC was negligent regarding the design or manufacture of the part. SCILLC is an Equal Opportunity/Affirmative Action Employer. This literature is subject to all applicable copyright laws and is not for resale in any manner.

PUBLICATION ORDERING INFORMATION

LITERATURE FULFILLMENT:

Literature Distribution Center for ON Semiconductor
P.O. Box 5163, Denver, Colorado 80217 USA
Phone: 303-675-2175 or 800-344-3860 Toll Free USA/Canada
Fax: 303-675-2176 or 800-344-3867 Toll Free USA/Canada
Email: orderlit@onsemi.com

N. American Technical Support: 800-282-9855 Toll Free
USA/Canada
Europe, Middle East and Africa Technical Support:
Phone: 421 33 790 2910
Japan Customer Focus Center
Phone: 81-3-5817-1050

ON Semiconductor Website: www.onsemi.com

Order Literature: <http://www.onsemi.com/orderlit>

For additional information, please contact your local
Sales Representative

Mouser Electronics

Authorized Distributor

Click to View Pricing, Inventory, Delivery & Lifecycle Information:

[ON Semiconductor:](#)

[STK672-040GEVB](#) [STK672-050GEVB](#)