

### STEVAL-MKI121V1: discovery kit for INEMO-M1

By Alessandra Di Pietro

#### Introduction

The STEVAL-MKI121V1 features the second generation of the iNEMO™ module family offered by STMicroelectronics. It combines INEMO-M1 and the pressure sensor LPS331AP, representing a new and complete 10-DoF (degree-of-freedom) open platform able to provide fast inertial application development using MEMS sensors and the STM32.

This user manual provides an overview of the system-on-board (SoB) and helps the user to discover the INEMO-M1 high-performance features and to develop and customize applications using the STEVAL-MKI121V1 and the graphical user interface (iNEMO suite) that is provided with the kit.

Figure 1. STEVAL-MKI121V1 demonstration board

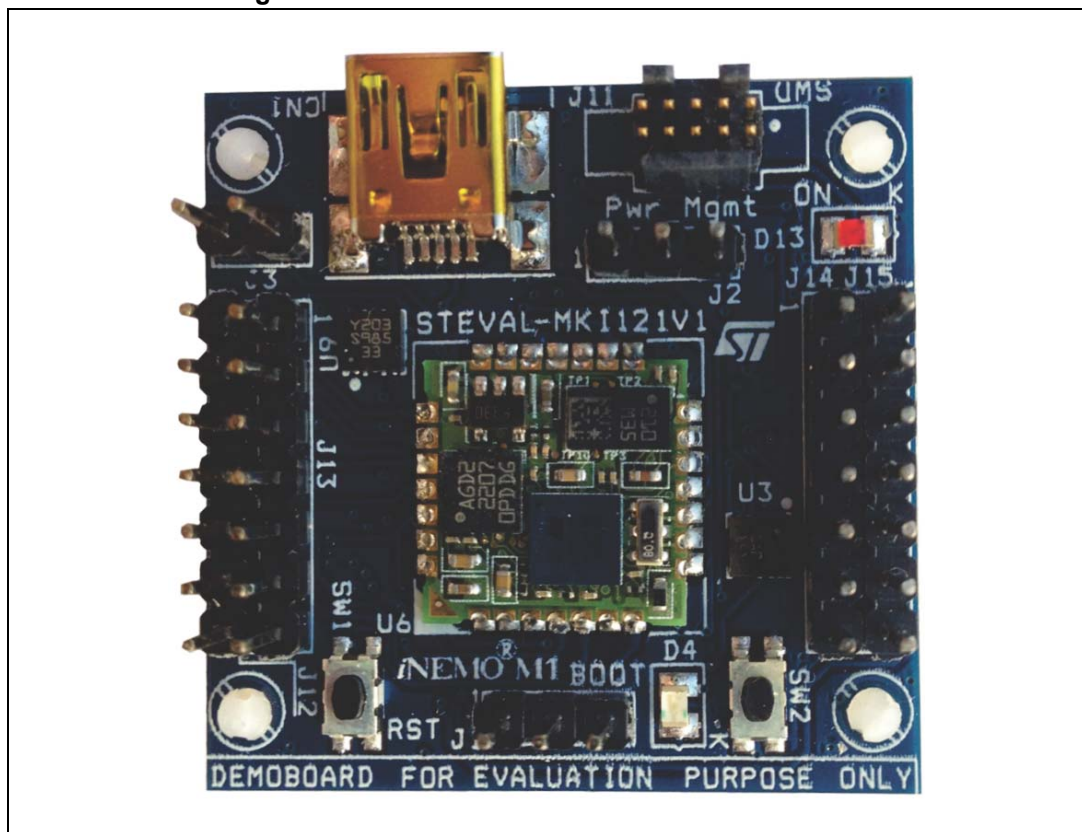

# Contents

- 1 Overview ..... 4**
  - 1.1 Features ..... 4
  - 1.2 Demonstration software ..... 4
  
- 2 Hardware layout and configuration ..... 5**
  - 2.1 Power supply and power selection ..... 6
    - 2.1.1 USB supply source ..... 6
    - 2.1.2 VEXT supply source ..... 7
    - 2.1.3 D\_VDD supply source ..... 7
  - 2.2 INEMO-M1 ..... 7
  - 2.3 LPS331AP MEMS pressure sensor ..... 9
  - 2.4 Serial wire debug (SWD) connector ..... 11
  - 2.5 Pushbuttons ..... 11
  - 2.6 LEDs ..... 11
  - 2.7 Extension connectors ..... 12
  - 2.8 USB ..... 15
  - 2.9 Jumpers ..... 16
  
- 3 Getting started with iNEMO suite ..... 17**
  - 3.1 iNEMO suite ..... 18
    - 3.1.1 iNEMO suite main window ..... 20
    - 3.1.2 Connecting iNEMO ..... 21
    - 3.1.3 Acquisition settings ..... 22
    - 3.1.4 Starting the acquisition and visibility of data ..... 24
    - 3.1.5 Starting the AHRS algorithm and settings ..... 24
    - 3.1.6 AHRS 3D demo ..... 25
    - 3.1.7 3D view alignment ..... 26
    - 3.1.8 Compass demo ..... 27
  
- Appendix A Schematics ..... 28**
  
- 4 Revision history ..... 35**

## List of figures

Figure 1.	STEVAL-MKI121V1 demonstration board	1
Figure 2.	iNEMO suite GUI	5
Figure 3.	STEVAL-MKI121V1 block diagram	6
Figure 4.	Top view - layout description	6
Figure 5.	Bottom view - layout description	7
Figure 6.	INEMO-M1	9
Figure 7.	INEMO-M1 functional block diagram	10
Figure 8.	Pressure sensor block diagram	11
Figure 9.	SWD connector (J11) and schematic	12
Figure 10.	USB mini-B connector (CN1) and schematic	16
Figure 11.	How to see the STEVAL-MKI121V1 COM port number	19
Figure 12.	Kit selector window	20
Figure 13.	iNEMO suite main window	21
Figure 14.	Selected COM port number	22
Figure 15.	New data file icon	22
Figure 16.	How to open the connection	23
Figure 17.	Acquisition settings	24
Figure 18.	Sensor settings	25
Figure 19.	3D cube demo	26
Figure 20.	3D cube demo - 3D view alignment	27
Figure 21.	Compass demo	28
Figure 22.	Reset, pushbutton, boot, user LED	29
Figure 23.	USB	30
Figure 24.	INEMO-M1 SoB	31
Figure 25.	Pressure sensor	32
Figure 26.	Power management stage	33
Figure 27.	SWD	34
Figure 28.	Pinout connectors	35

# 1 Overview

## 1.1 Features

- Two power supply options
  - through the USB connector (5 V), or
  - from an external supply voltage (3.6 V - 6 V VEXT or 2.4 V - 3.6 V D\_VDD)
- INEMO-M1: 9-axis SoB, 13x13x2 mm compact design
- LPS331AP: MEMS pressure sensor 260-1260 mbar absolute digital output barometer
- Extension header for INEMO-M1 I/Os for quick connections to prototype the board and for easy probing
- SWD connector for programming and debugging
- Two push buttons (reset and user)
- Two LEDs (user LED, power-on LED)
- Mini-B USB connector

## 1.2 Demonstration software

To facilitate user development and analysis of the sensor data, the STEVAL-MKI121V1 demonstration kit includes a graphical user interface (GUI), iNEMO suite, to display sensor outputs, the compass application, AHRS 3D demo cube<sup>(a)</sup>, as well as a firmware library for easy development of customized applications and a package for a DFU (Device Firmware Upgrade).

The iNEMO suite application allows the user to also work with the previous iNEMO V1 and iNEMO V2 platforms. At the startup of the application, the kit selector window appears, in order to choose the platform used (select STEVAL-MKI121V1 in this case). For more details on getting started with the iNEMO suite, please refer to [Section 3](#).

The latest version of the firmware package and PC GUI can be downloaded from the STEVAL-MKI121V1 product page on [www.st.com](http://www.st.com).

Figure 2. iNEMO suite GUI



a. The STEVAL-MKI121V1 runs the AHRS 3D demo cube, but the firmware library doesn't include the AHRS algorithm which is available in the STEVAL-MKI121CD1 CD.

## 2 Hardware layout and configuration

The STEVAL-MKI121V1 discovery board has been designed to evaluate the INEMO-M1 features.

Figure 3 illustrates the hardware block diagram of the device.

Figure 3. STEVAL-MKI121V1 block diagram

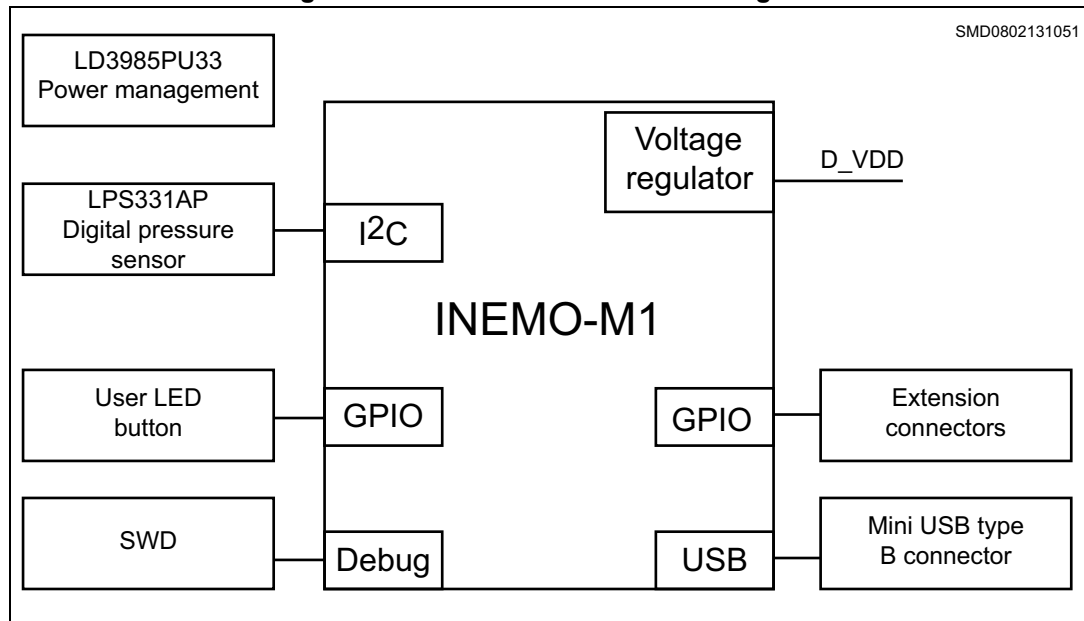

Figure 4 illustrates the top view of the layout and Figure 5 shows the bottom view.

Figure 4. Top view - layout description

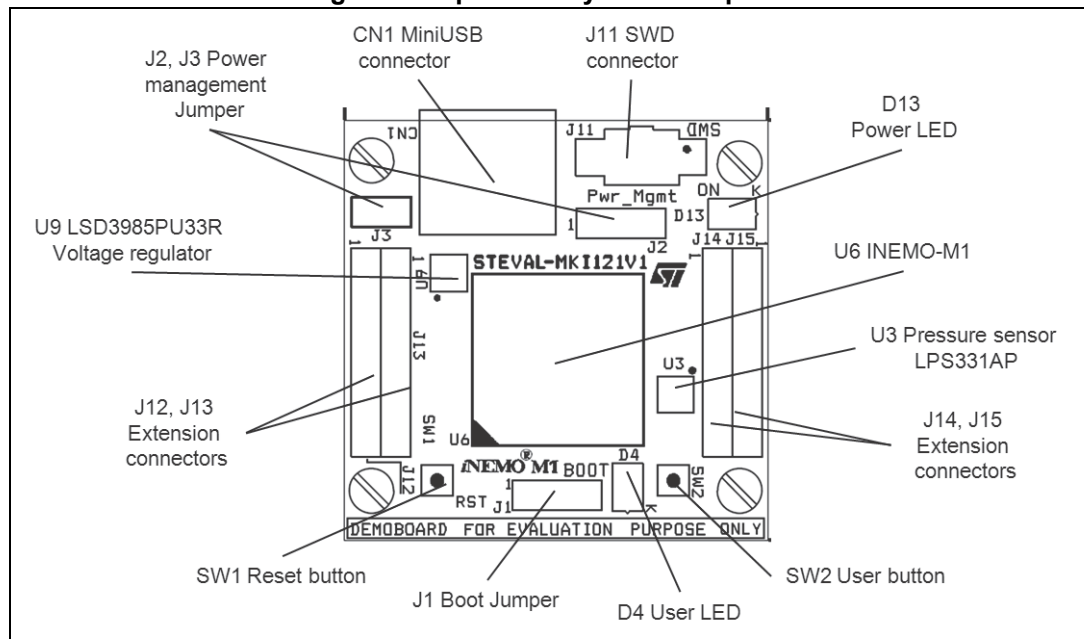
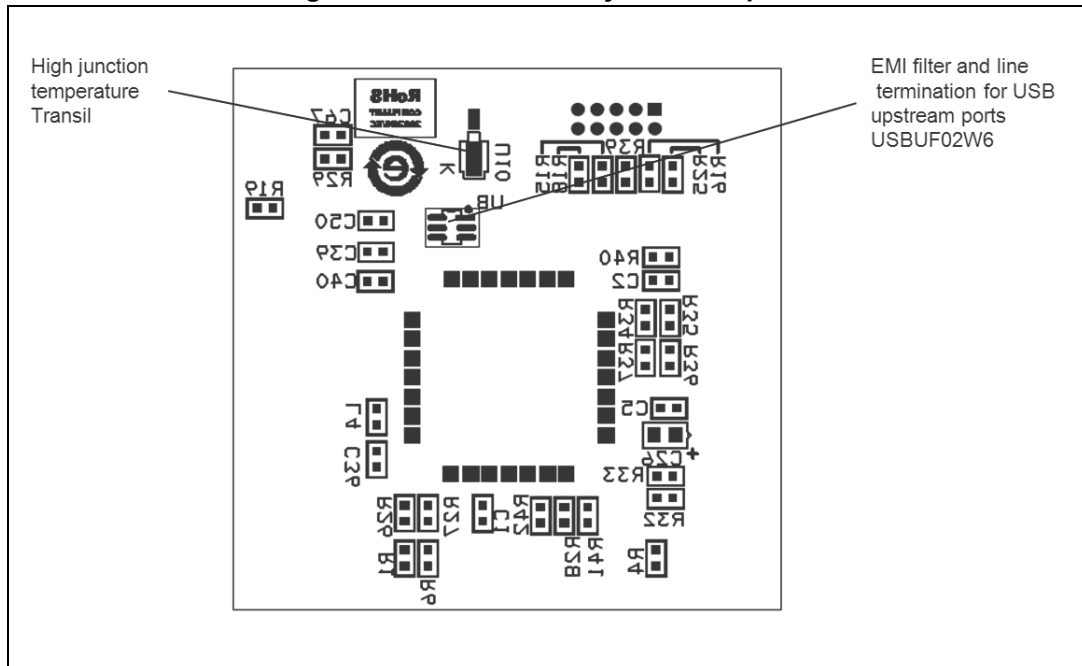

Figure 5. Bottom view - layout description



## 2.1 Power supply and power selection

The STEVAL-MKI121V1 can be powered through a USB connector or an external power supply voltage up to 6 V DC as follows:

- 5 V DC power from type B mini USB connector
- 3.6 to 6 V DC power from VEXT (pin1 of the J15 extension connector)
- 2.4 to 3.6 V DC power from D\_VDD (pin1 of the J12, J13 or J14 extension connector)<sup>(b)</sup>

### 2.1.1 USB supply source

If the STEVAL-MKI121V1 is supplied through the USB connector, one of two options can be selected to regulate the voltage:

- INEMO-M1 internal voltage regulator
- STEVAL-MKI121V1 (LSD3985PU33R) voltage regulator

The voltage regulator is selected using J2 and J3 according to [Table 1](#). The LED D13 is turned on if the board is powered correctly.

b. The VEXT pin has to be left floating

**Table 1. Power selection options**

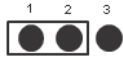
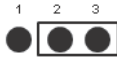
Regulator	J2 jumper configuration	J3 jumper configuration
STEVAL-MKI121V1 (LSD3985PU33R) voltage regulator		ON
NEMO-M1 internal voltage regulator		x

**2.1.2 VEXT supply source**

The STEVAL-MKI121V1 is powered by VEXT, connecting the voltage source to pin 1 of the J15 extension connector.

The input voltage value shall be in the range 3.6 - 6 V and it is regulated in this case by the internal INEMO-M1 voltage regulator.

**2.1.3 D\_VDD supply source**

The STEVAL-MKI121V1 is powered by D\_VDD, connecting the voltage source to pin1 of the J12 or J13 or J14 extension connector.

The input voltage value shall be in the range 2.4 - 3.6 V. In this case the INEMO-M1 internal voltage regulator is bypassed, so the VEXT pin has to be left floating.

**2.2 INEMO-M1**

The INEMO-M1 is the smallest sensor fusion system-on-board (SoB) of the iNEMO module family.

The INEMO-M1 is a 9-degree-of-freedom system-on-board (SoB), combining the latest advances in ST MEMS-based technology with the powerful computational core (ARM® Cortex™-M3) of the STM32 family. The INEMO-M1 platform has been designed following specific guidelines in order to have a modular solution based on the principles of miniaturization, low power consumption and cost effectiveness, obtaining a solution having the best trade-off between performance and flexibility of the system to cover a wide range of applications.

Figure 6. INEMO-M1

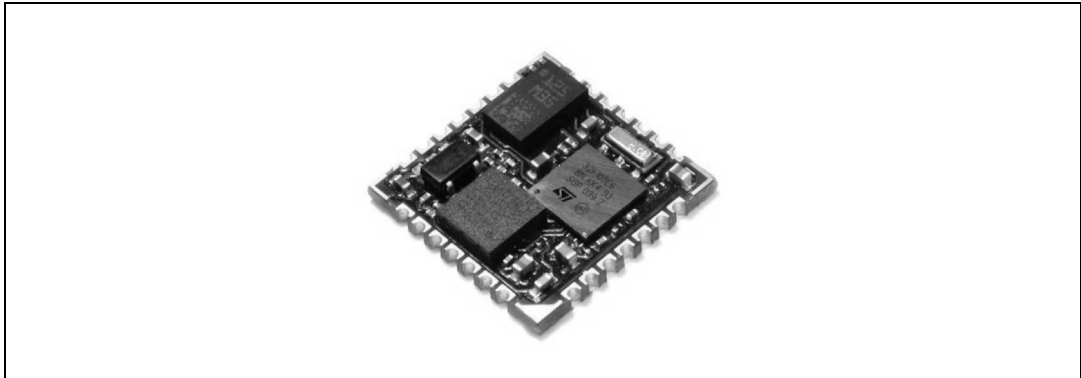

This SOB provides the following benefits.

- The INEMO-M1 operates from a 2.4 V - 3.6 V power supply voltage range. Additionally, the internal voltage regulator LDS3985M33R enables the module to be powered by an external voltage from 3.6 up to 6 V, correctly supplying the devices on-board and also supplying external ICs
- The INEMO-M1 architecture embeds the:
  - STM32F103REY6: WLCSP package, high density performance line ARM<sup>®</sup> Cortex<sup>™</sup>-M3 based 32-bit MCU
  - LSM303DLHC: 6-axis geomagnetic module,  $\pm 2g$ ,  $\pm 4g$ ,  $\pm 8g$ ,  $\pm 16g$  linear acceleration programmable full scale, and from  $\pm 1.3$  Gauss to  $\pm 8.1$  Gauss magnetic programmable field full scale, I<sup>2</sup>C digital output
  - L3GD20: 3-axis digital gyroscope (roll, pitch, yaw), 16-bit data output,  $\pm 250^\circ/s$ ,  $\pm 500^\circ/s$ ,  $\pm 2000^\circ/s$  selectable full scale
  - LDS3985M33R: ultra-low drop-low noise BiCMOS 300 mA voltage regulator
- The INEMO-M1 has been designed to exploit a wide range of peripherals (CAN, USART, SPI and I<sup>2</sup>C, full-speed USB 2.0) supported by the STM32F103REY6, in order to have the maximum flexibility in communication. Thanks to this full range of communication peripherals and its extremely compact design, the INEMO-M1 can be directly integrated in a broad variety of advanced motion-based platforms in several application segments, resulting in enhanced performance of the platform as the system's capabilities are accessible within the application.
- Free ADC channels for external inputs
- Low-power modes: power-down/sleep
- In-system ceramic resonator
- In-application programming (IAP) interfaces for firmware upgrades
- Compact design: 13 x 13 x 2 mm

For further information, please consult the INEMO-M1 datasheet and the STM32 reference and Flash programming manuals which are available from STMicroelectronics at [www.st.com](http://www.st.com).



Figure 7. INEMO-M1 functional block diagram

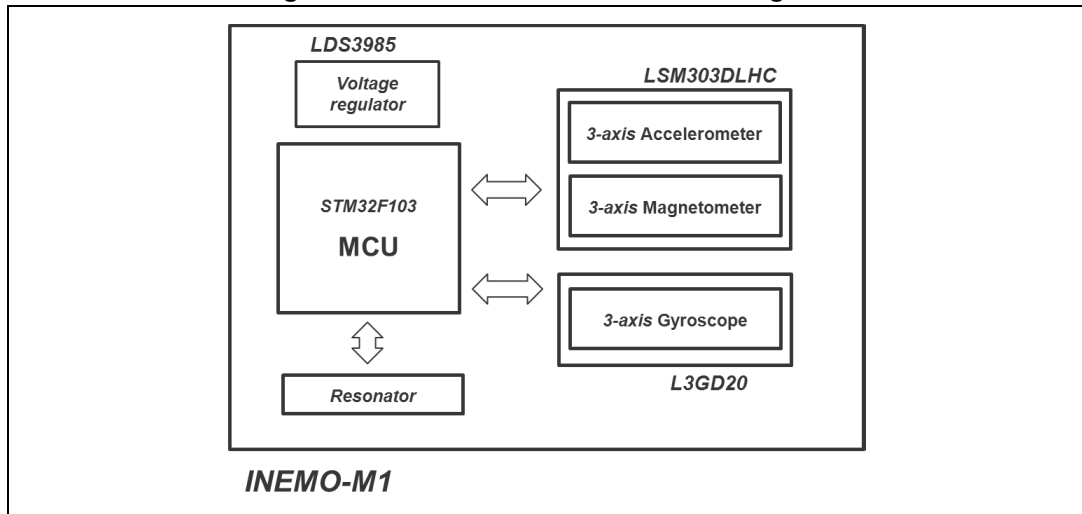

## 2.3 LPS331AP MEMS pressure sensor

The LPS331AP is an ultra-compact absolute piezoresistive pressure sensor housed in an HCLGA package.

The device includes a monolithic sensing element and an IC interface able to take the information from the sensing element and to provide a digital signal to the external world. The sensing element consists of a suspended membrane inside a single mono-silicon substrate. It is capable of detecting pressure and is manufactured using a dedicated process (VENSENS) developed by ST.

The STEVAL-MK1121V1 board uses an I<sup>2</sup>C communication (I2C1 on pin 12 and pin 13 of INEMO-M1) and the LPS331AP slave address is set to 0xBA. The LPS331AP features two fully programmable interrupt sources (INT1 and INT2) which may be configured to trigger different pressure events. In the STEVAL-MK1121V1, only the INT1 interrupt source is connected to the INEMO-M1 through Press\_INT (pin 7 of INEMO-M1). The device may also be configured to generate, through the interrupt pins, a data ready signal (Drdy), which indicates when new measured data is available, therefore simplifying data synchronization in digital systems. The connection between the LPS331AP and the INEMO-M1 is shown in [Figure 8](#).

*Note:* I2C1 and INT1 (Press\_INT) can be disconnected from the pressure sensor and reconfigured for other purposes, simply by removing dedicated resistors as described in [Table 3](#).

Figure 8. Pressure sensor block diagram

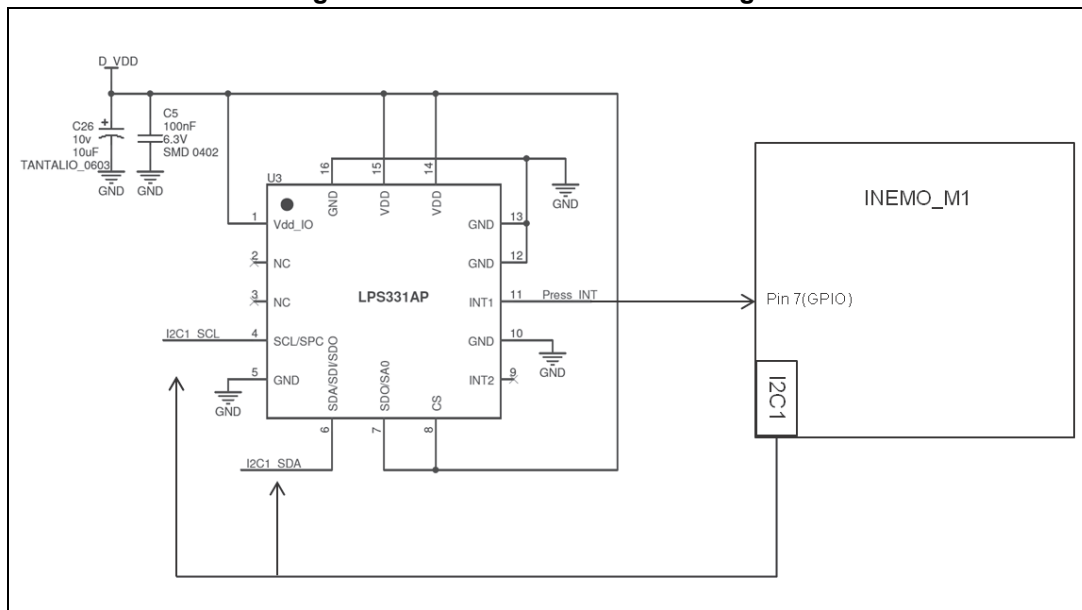

## 2.4 Serial wire debug (SWD) connector

The SWD connector allows program loading and debugging of the STM32 inside INEMO-M1 using a SWD dongle (like ST-LINK/V2) through a dedicated JTAG\_SWD adapter board.

A specific driver needs to be installed on the user's PC for communication with the SWD dongle.

Figure 9. SWD connector (J11) and schematic

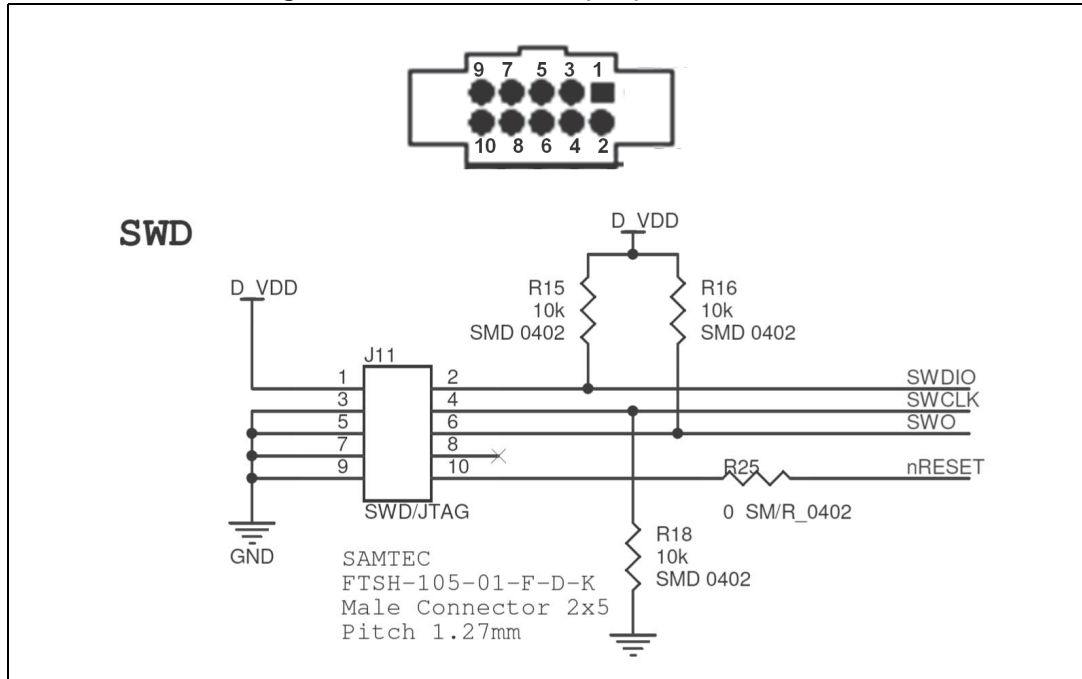

## 2.5 Pushbuttons

- SW1: reset pushbutton connected to nRESET is used to reset the INEMO-M1
- SW2: user button connected to pin 16 of INEMO-M1

*Note:* The user button can be disconnected from SW2 and reconfigured for other purposes simply by removing the dedicated resistor as described in [Table 3](#).

## 2.6 LEDs

- D4: Blue LED is a user LED connected to the I/O pin 26 of INEMO-M1
- D13: Red LED indicates that the board is powered.

*Note:* The user LED can be disconnected from D4 and reconfigured for other purposes simply by removing the dedicated resistor as described in [Table 3](#).

## 2.7 Extension connectors

Four 7-pin male connectors J12, J13, J14 and J15 can be used to connect a user’s daughterboard to facilitate the development of applications.

Each pin on the connectors can be utilized by the user’s daughterboard, a lot of these are free I/Os and others can be used after disconnecting them from the corresponding functional block on the STEVAL-MKI121V1 board. Please refer to [Table 2](#) and [Table 3](#).

**Table 2. INEMO-M1 pin description versus board function**

INEMO-M1 pin #	Description	Basic Function	Remap	MCU pin name	STEVAL-MKI121V1 I/O assignment	Free I/O	Pin # of J12	Pin # of J13	Pin # of J14	Pin # of J15
1	VDD (2.4 - 3.6 V) <sup>(1)</sup>				D_VDD		1	1	1	
2	BOOT0			BOOT0	BOOT0			2		
3	nRESET			NRST	Reset button				2	
4	GPIO_PA3	USART2_RX / TIM5_CH4 / ADC123_IN3 / TIM2_CH4		PA3				4		
5	GPIO_PA2	USART2_TX / TIM5_CH3 / ADC123_IN2 / TIM2_CH3		PA2				5		
6	GND				GND			7	7	7
7	GPIO_PA0	WKUP / USART2_CTS / ADC123_IN0 / TIM2_CH1_ETR / TIM5_CH1 / TIM8_ETR		PA0-WKUP	LPS331AP( Press_INT) <sup>(2)</sup>			6		
8	GPIO_PA11	USART1_CTS / USBDM / CAN_RX / TIM1_CH4		PA11					6	
9	GPIO_PA12	USART1_RTS / USBDP / CAN_TX / TIM1_ETR		PA12					5	
10	GPIO_PB6	I2C1_SCL / TIM4_CH1	USART1_TX	PB6					4	
11	GPIO_PB7	I2C1_SDA / TIM4_CH2	USART1_RX	PB7					3	

Table 2. INEMO-M1 pin description versus board function (continued)

INEMO-M1 pin #	Description	Basic Function	Remap	MCU pin name	STEVAl-MK121V1 I/O assignment	Free I/O	Pin # of J12	Pin # of J13	Pin # of J14	Pin # of J15
12	GPIO_PB9	TIM4_CH4	I2C1_SDA / CAN_TX	PB9	LPS331AP (I2C1) <sup>(2)</sup>					6
13	GPIO_PB8	TIM4_CH3	I2C1_SCL / CAN_RX	PB8	LPS331AP (I2C1) <sup>(2)</sup>					5
14	GND				GND			7	7	7
15	GND				GND			7	7	7
16	GPIO_PA10	USART1_RX / TIM1_CH3		PA10	User Button (Push Button) <sup>(2)</sup>		7			
17	JTDO	JTDO	PB3 / TRACES WO / TIM2_CH2 / SPI1_SCK	PB3	SWD (SWO)					4
18	GPIO_PA9	USART1_TX / TIM1_CH2		PA9	USB_EN <sup>(2)</sup>		6			
19	JTMS-SWDIO	JTMS-SWDIO	GPIO_PA13	PA13	SWD (SWDIO)					3
20	JTCK-SWCLK	JTCK-SWCLK	GPIO_PA14	PA14	SWD (SWCLK)					2
21	VEXT (3.6 - 6 V) <sup>(3)</sup>				V_EXT					1
22	GPIO_PA4	SPI1_NSS / USART2_CK / DAC_OUT1 / ADC12_IN4		PA4			2			
23	GPIO_PA5	SPI1_SCK / DAC_OUT2 / ADC12_IN5		PA5			3			
24	GPIO_PA6	SPI1_MISO / TIM8_BKIN / ADC12_IN6 / TIM3_CH1	TIM1_BKIN	PA6			4			
25	GPIO_PA7	SPI1_MOSI / TIM8_CH1N / ADC12_IN7 / TIM3_CH2	TIM1_CH1N	PA7			5			
26	GPIO_PA1	USART2_RTS / ADC123_IN1 / TIM5_CH2 / TIM2_CH2		PA1	USER_LED <sup>(2)</sup>			3		

**Table 2. INEMO-M1 pin description versus board function (continued)**

INEMO-M1 pin #	Description	Basic Function	Remap	MCU pin name	STEVAL-MKI121V1 I/O assignment	Free I/O	Pin # of J12	Pin # of J13	Pin # of J14	Pin # of J15
27	VDD (2.4 - 3.6 V) <sup>(1)</sup>				D_VDD		1	1	1	
28	GND				GND			7	7	7

1. When using an external regulated supply voltage, these pins are input supply pins with voltage in the range 2.4 V - 3.6 V. When using the internal voltage regulator, these pins are @3.3 V (output) and can be used to supply other ICs.
2. Can be reconfigured by the user by removing the related resistor, please refer to [Table 3](#).
3. When using an external regulated supply voltage, this pin shall be left floating. When using the internal voltage regulator, this pin is used as the supply input in the range 3.6 V- 6 V.

**Table 3. Functional block disconnection on STEVAL-MKI121V1**

INEMO-M1 pin number	STEVAL-MKI121V1 I/O assignment	How to disconnect from functional block on STEVAL-MKI121V1 board
7	Press_INT	Remove R41
12	I2C1_SDA	Remove R37
13	I2C1_SCL	Remove R34
16	Push_Button	Remove R40
18	USB_EN	Remove R39
26	USER_LED	Remove R42

## 2.8 USB

The STEVAL-MKI121V1 is provided with USB 2.0 compliant full-speed communication via a USB type mini-B receptacle connector (CN1), with dedicated EMI filter and line termination through the USBUF02W6 (U8). Pin 18 of the INEMO-M1 is used for the software connection/disconnection of the USB cable. The MCU pins are configured in output push-pull mode: when high, the USB communication is enabled; when low, it is disabled. Connector and hardware connections are shown in [Figure 10](#).

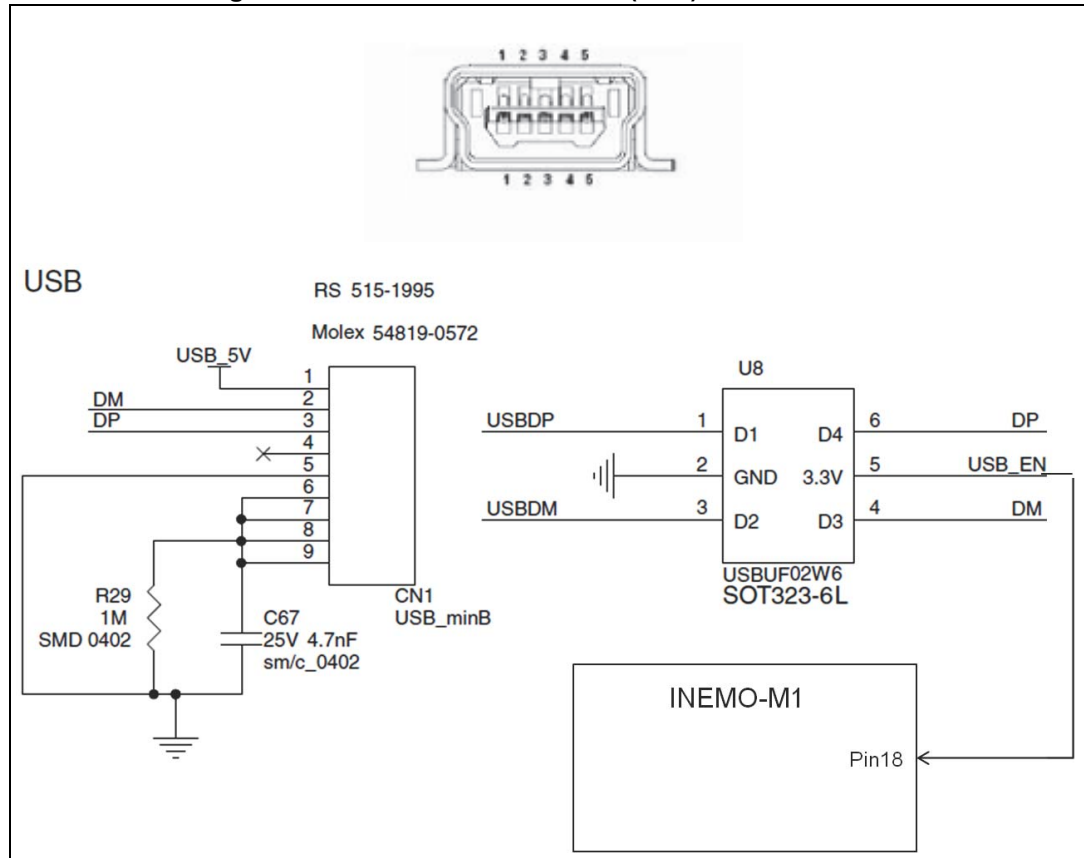
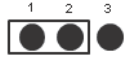
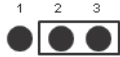
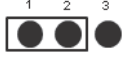

**Figure 10. USB mini-B connector (CN1) and schematic**



## 2.9 Jumpers

The details of the jumper settings are described in [Table 4](#).

**Table 4. J1, J2, J3 settings**

Jumper	Description
J1	BOOT0 is connected to D_VDD power when J1 is set as shown below. System memory is selected as boot space 
	BOOT0 is connected to GND when J1 is set as shown below. Main Flash memory is selected as boot space 
J2	USB_5V is connected to VREG_LDS when J2 is set as shown below. The input voltage is regulated to 3.3 V by LDS3985PU33R and J3 has to be on to power the INEMO-M1 module. 
	USB_5V is connected to V_EXT when J2 is set as shown below. The input voltage is regulated internally by the INEMO-M1 module 
J3	Jumper on: D_VDD is connected to 3.3 V, regulated by the LDS3985PU33R regulator Jumper off: D_VDD is not connected to 3.3 V. It can be regulated by the INEMO-M1 internal regulator or it can be the voltage source coming from pin1 of the J12 or J13 or J14 extension connector.



## 3 Getting started with iNEMO suite

The installation of the graphical user interface (GUI) requires the following two steps:

1. Install the PC software delivered with the demonstration kit
2. Install the virtual COM driver needed to use the board

### PC system requirement

- Microsoft Windows XP® Service Pack 2, or higher
- Microsoft.NET Framework 2.0 (or higher)

### PC software installation

To install the iNEMO suite, run the setup file and follow the instructions.

*Note:* The latest setup file is available on [www.st.com](http://www.st.com).

### Virtual Com driver installation

To install the virtual COM driver, plug the iNEMO board into a free USB port, an icon should appear in the “Notify Bar”. Wait for the “Hardware Update Wizard” window and follow the instructions:

- Install from a list or specific location (Advanced)
- Browse C:\Program Files\STMicroelectronics\iNEMO Suite\driver inemo and choose x64 or x86 folder according to your system.

Once the installation has finished, a COM port number is assigned to the ST virtual COM driver ([Figure 11](#)). This number is required to correctly run the iNEMO GUI as outlined in the steps in [3.1: iNEMO suite](#).

Figure 11. How to see the STEVAL-MKI121V1 COM port number

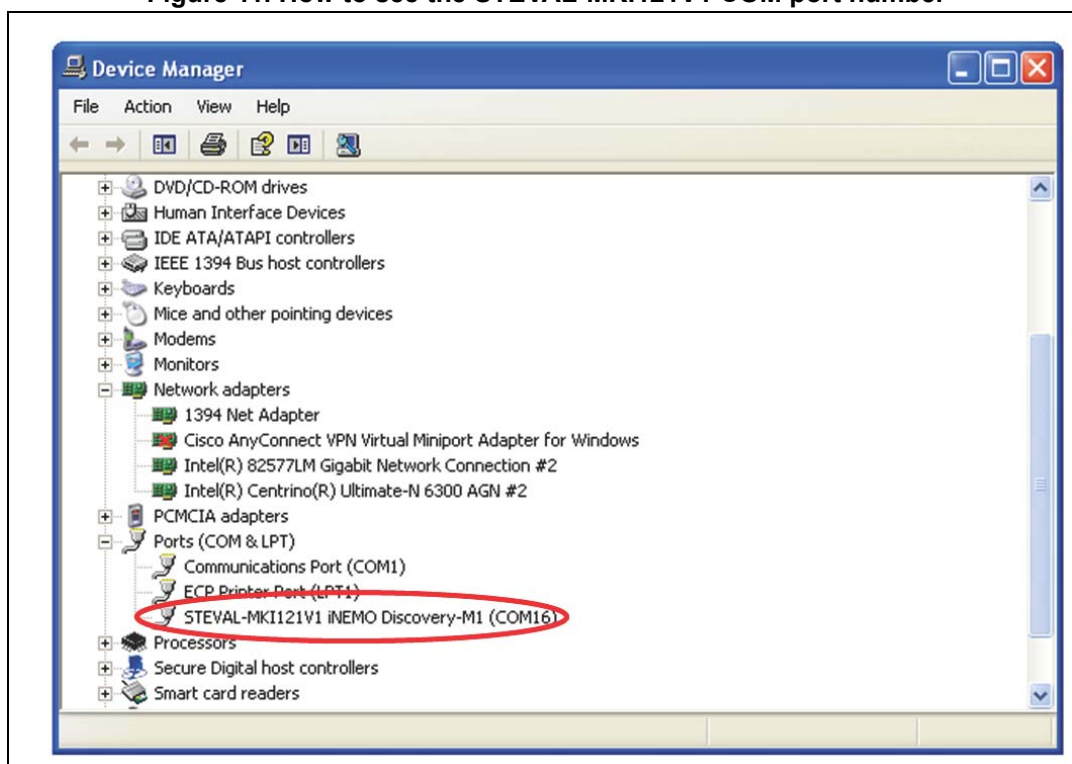

### 3.1 iNEMO suite

The iNEMO suite application allows the user to also work with the iNEMO V1 and iNEMO V2 platform. At the startup of the application, the kit selector window appears in order to choose the platform to be used (*Figure 12*).

For the STEVAL-MKI121V1 the iNEMO suite application also has a TCP/IP server for external/remote demo applications. When the server starts, in the log bar a message shows the availability of the server. Each client may be connected to the server on port 31001 (default) to receive data from the device through the iNEMO suite (server).

Every time a client connects to the server, the log bar shows the IP address of the client that just connected.

Each demo (client) can elaborate and show these data. (The structure of the data sample sent to all clients is `FrameData_t` defined in the `iNEMOM1_SDK.h` file).

The TCP/IP server may be enabled/disabled from the Tools->Communication->Settings menu (its state is shown on the status bar). From this dialog box, the user can change the communication port (default 31001). Pay close attention to this information in order to avoid a communication block from an installed firewall.

To run the iNEMO suite:

1. Click on Start > All Programs > STMicroelectronics > iNEMO Suite > iNEMO Suite Application
2. Launch the iNEMO software tool program (Goldfish icon)
3. The “Kit Selector” window appears (Figure 12). Select STEVAL-MKI121V1.
4. Check that the serial port is correct (see Figure 11). Otherwise click the refresh button and choose the right COM port.

It is preferable to connect the iNEMO board to a free USB port before launching the GUI. In this way, the GUI directly finds the COM port into which the board is plugged.

To change the COM port, press the “New” button on the toolbar (Figure 15) or from the menu File/New and the kit selector dialog window appears.

Figure 12. Kit selector window

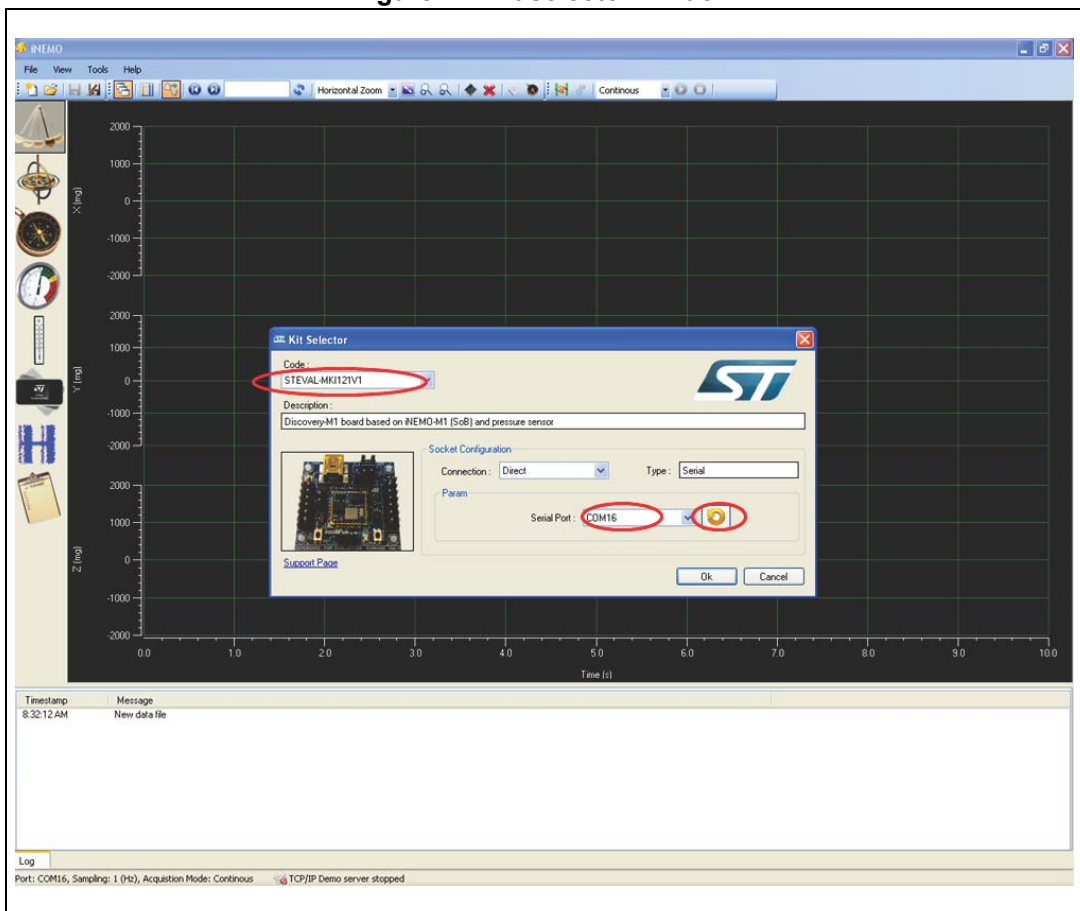

### 3.1.1 iNEMO suite main window

The main window contains the following sections referenced by the corresponding numbers in *Figure 13*:

1. Sensor selector which allows the user to move to a different sensor data view
2. Toolbar for data acquisition setting, to set frequency, acquisition mode, etc.
3. Toolbar for graphic management helps the user to explore the graphic window. It allows zooming in on the graph, enabling the cursors, saving data, and so on
4. Status bar shows the acquisition info
5. Log window
6. Default menu bar
7. Graph where the data are plotted

Figure 13. iNEMO suite main window

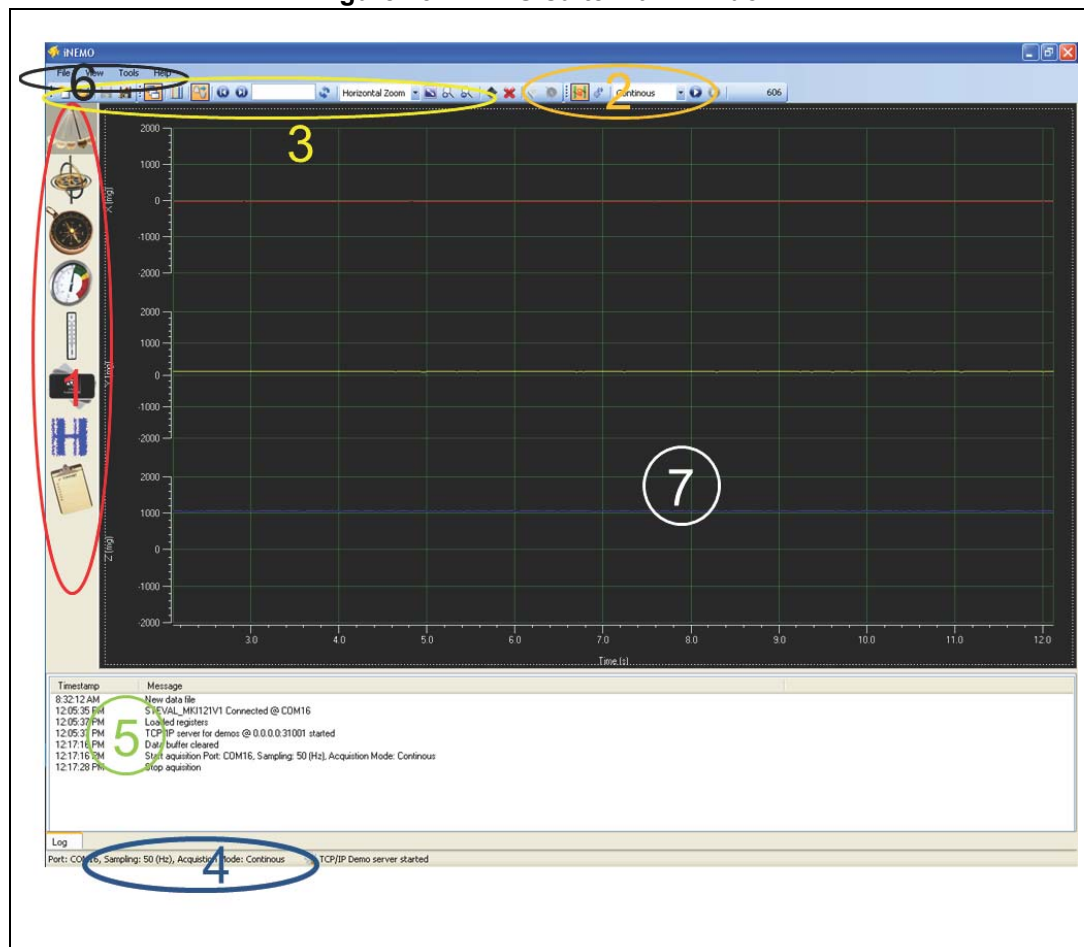

### 3.1.2 Connecting iNEMO

Before starting the acquisition of data, it is necessary to open the connection between iNEMO and the PC. It is preferable to connect the iNEMO board to a free USB port before launching the GUI. In this way, the GUI directly finds the COM port into which the board is plugged.

The bottom part of the GUI main window shows the COM port number, see [Figure 14](#).

Figure 14. Selected COM port number

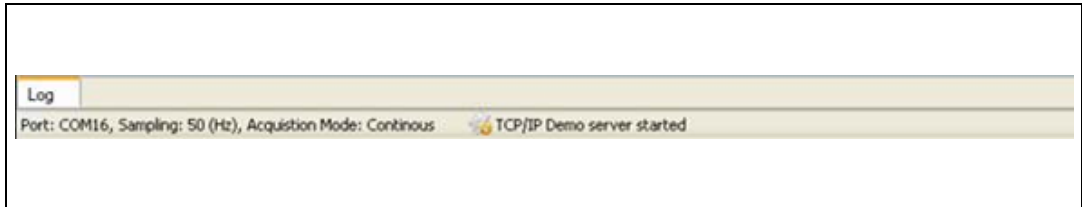

The user must check that the COM port number is the same as the one shown in the device manager ([Figure 11](#)).

If the COM number is different, it is necessary to set the right number. By clicking the new data file icon ([Figure 15](#)), the kit selector window appears and it is possible to select the COM port number as in [Figure 12](#).

Figure 15. New data file icon

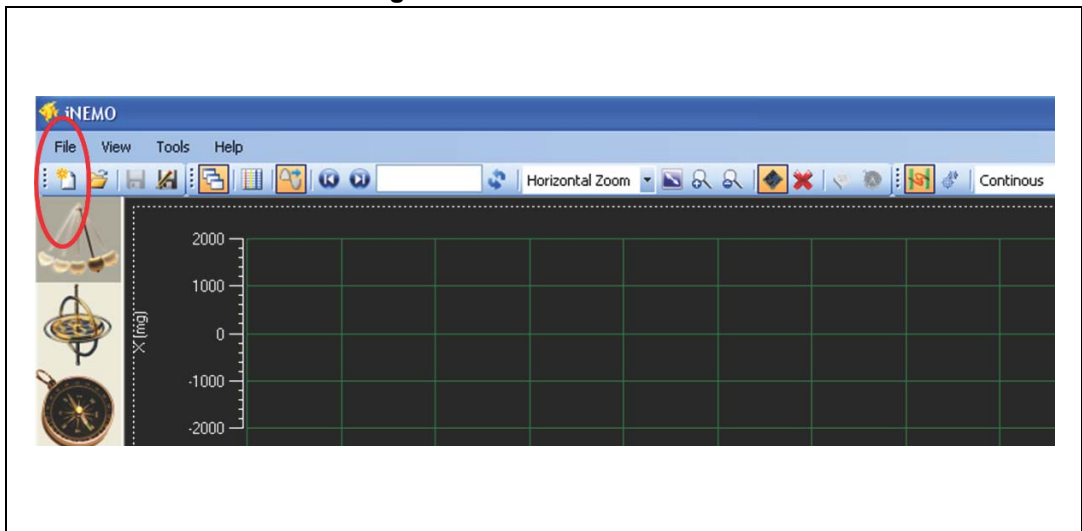

When the correct COM number is set, click on the connect icon to open the communication and, in the log window, a connection message appears (*Figure 16*).

**Figure 16. How to open the connection**

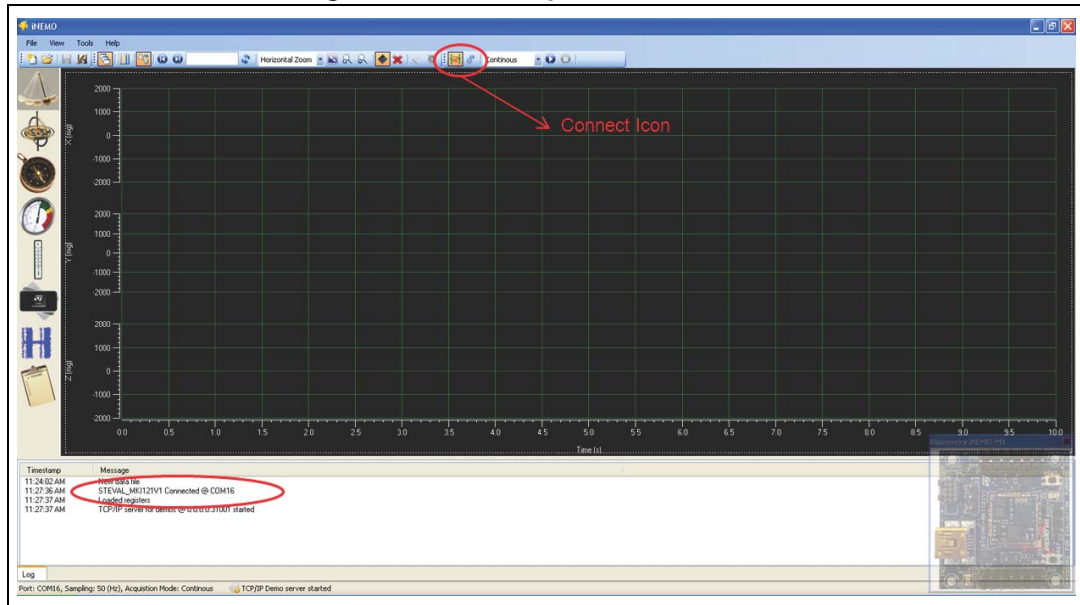

### 3.1.3 Acquisition settings

Before starting the acquisition it is possible to modify the acquisition setting (*Figure 17*):

- Sensor output:
  - Enable/disable the output of a sensor
- Acquisition mode:
  - Raw data: sensor data plotted as raw data in the graph
  - AHRS: this feature enables the attitude heading reference system algorithm based on the Kalman filter and sends sensor data plus orientation data
  - Compass: this feature enables the compass application. To show compass application press the compass icon
  - Sampling frequency: it sets the acquisition rate of the sensors. If only one sensor is enabled, by checking the synchronous flag, the sampling frequency are synchronized with the value of the output data rate of the relevant sensor. Otherwise, the sampling frequency and output data rate can be set with a different value.
- Acquisition duration:
  - Samples: iNEMO acquires data from a limited number of sensors, set in the “number of samples” box
  - Continuous: iNEMO acquires data until the user stops the acquisition by clicking the “Stop” button

When the AHRS feature is enabled, the sampling frequency is automatically set to 50 Hz, and it can't be modified.

Figure 17. Acquisition settings

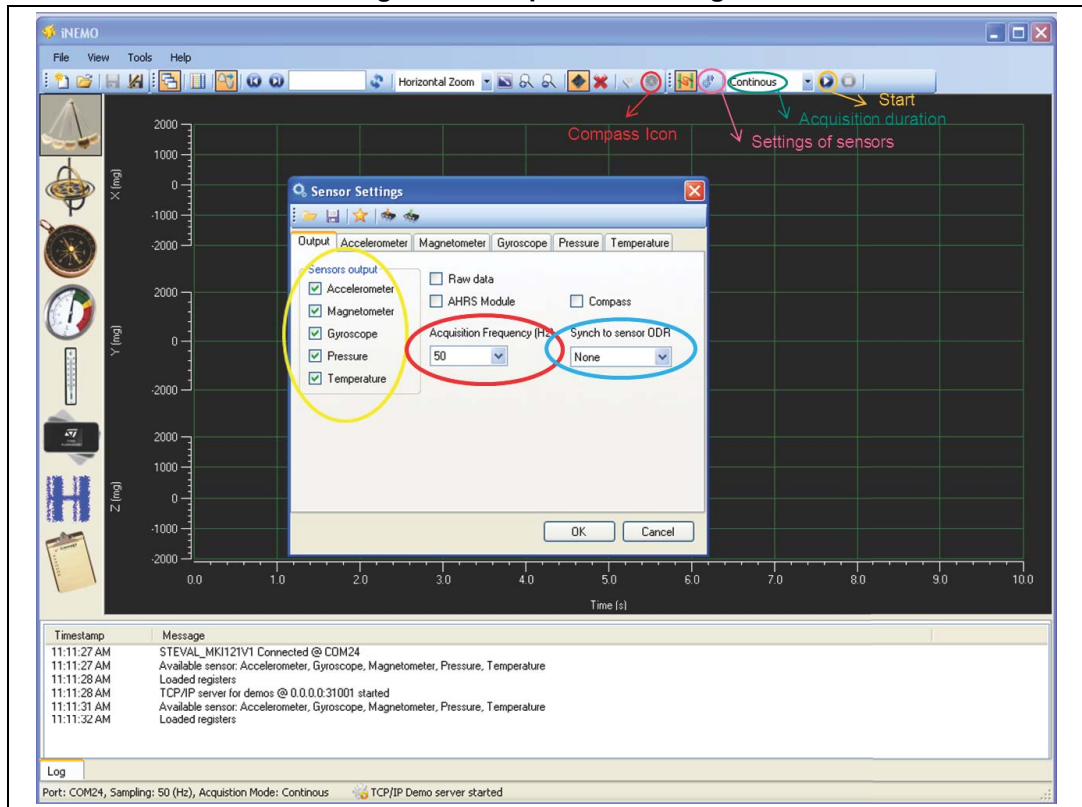

For each sensor it is possible to set parameters like offset, scale factor, output data rate, full scale, as well as other ones related to selecting sensors. The output data rate can be synchronized with the sampling frequency of one sensor selected from the “Sync to sensor ODR” drop-down menu.

The sensor settings can be also saved/loaded to/from flash (Figure 18). This functionality is useful for board calibration.

Figure 18. Sensor settings

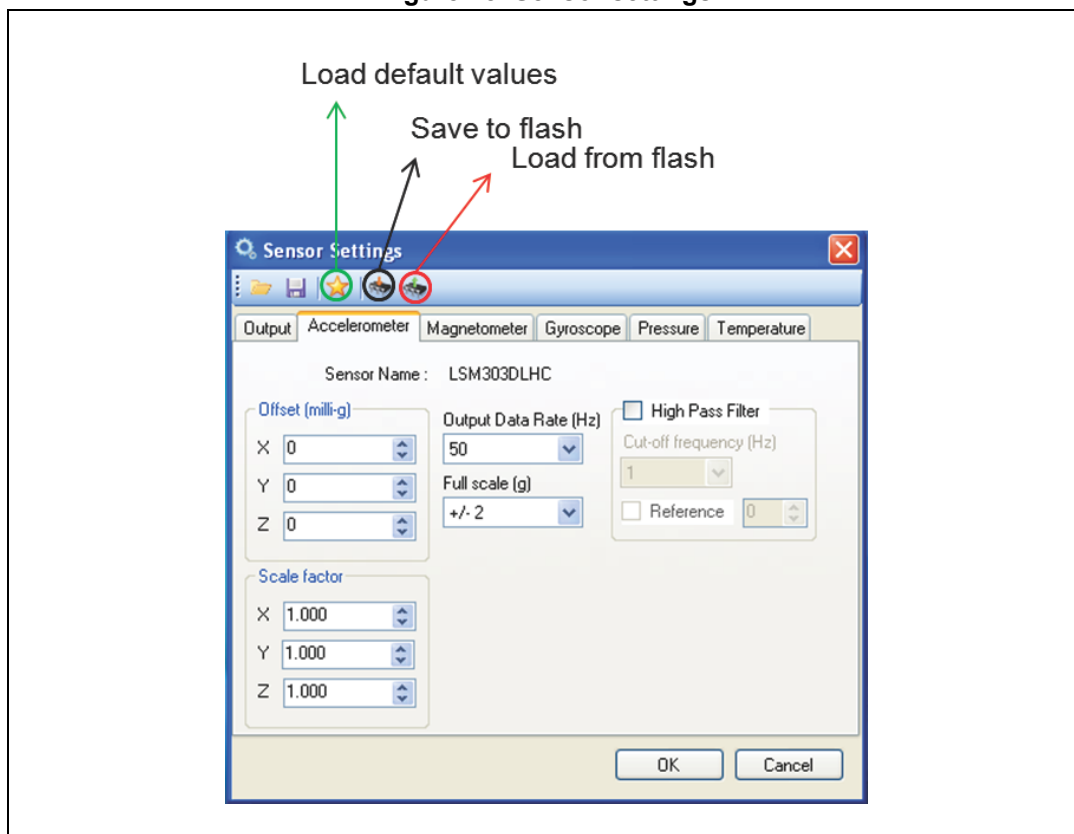

### 3.1.4 Starting the acquisition and visibility of data

By clicking the “Start” icon, the acquisition starts. The user can view the sensor data in the graphics. Each sensor is acquired simultaneously but it has a dedicated graphic, the user can choose the sensor using the icons on left of the GUI.

### 3.1.5 Starting the AHRS algorithm and settings

When the AHRS algorithm is enabled (see [Section 3.1.3](#) and [Figure 17](#)), the iNEMO MCU executes the extended Kalman filter to retrieve information about the board orientation starting from the acceleration, angular rate, and magnetic field data.

The orientation data are sent to the PC in two ways: roll, pitch, and yaw (RPY) angles and quaternion.

When the AHRS acquisition has begun, the user must check that the data are stable which means checking, in the RPY graphic, that the data are flat when iNEMO is in a stationary position.

If not, the user must strongly shake the board and, after that, leave the board in a motionless position while waiting for flat data (sometimes it may be necessary to do this operation more than once).



### 3.1.6 AHRS 3D demo

If AHRS 3D is enabled, it is possible, by clicking on the “Run\Stop 3D Demo icon”, to open a 3D window in which an orientation demo is performed.

The “iNEMO 3D Cube Demo” is an external client application whose connection is automatically made by the external client. It is also possible to start the application from the system menu Start/Programs/STMicroelectronics/iNEMO Suite/Demos/3D Cube Demo/ or launch from a console with the command “iNEMO 3D Cube Demo.exe IP=xxx.yyy.www.zzz, PORT=31001”, where xxx.yyy.www.zzz is the IP address of the server. The application can also be run from a remote PC which is in the same network as the server. More than one instance of the application can run on the same PC or remotely, it depends on the network speed connection and the PC processor speed and RAM.

From the 3D cube window it is possible to execute the following useful commands:

- ESC - to close the window alignment
- F1 - to hide or show window help
- F2 - to align the 3D view towards the monitor (see [3.1.7: 3D view alignment](#))
- F3 - to show roll, pitch, and yaw values
- F4 - to show quaternion values

Figure 19. 3D cube demo

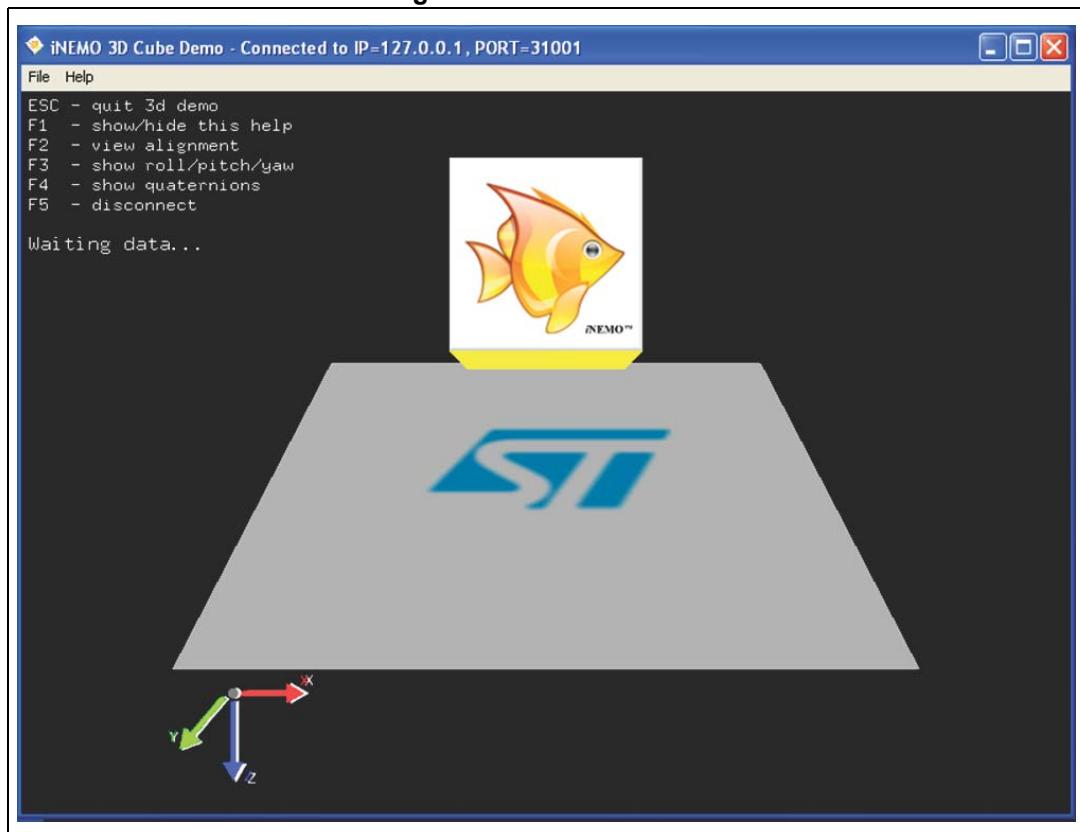

### 3.1.7 3D view alignment

The AHRS reference frame is aligned to the magnetic north (see [Figure 19](#) for reference) which means that the yaw angle value is referenced to the magnetic north. In order to better understand the tracked motion, it can be useful to realign the rotation in the direction of the monitor, by using the view alignment operation (it is just a transformation of the reference).

To align iNEMO, it is necessary to point the USB cable towards the monitor and press the F2 key. If the calibration is correct, the cube shows the “goldfish” side ([Figure 20](#)).

Figure 20. 3D cube demo - 3D view alignment

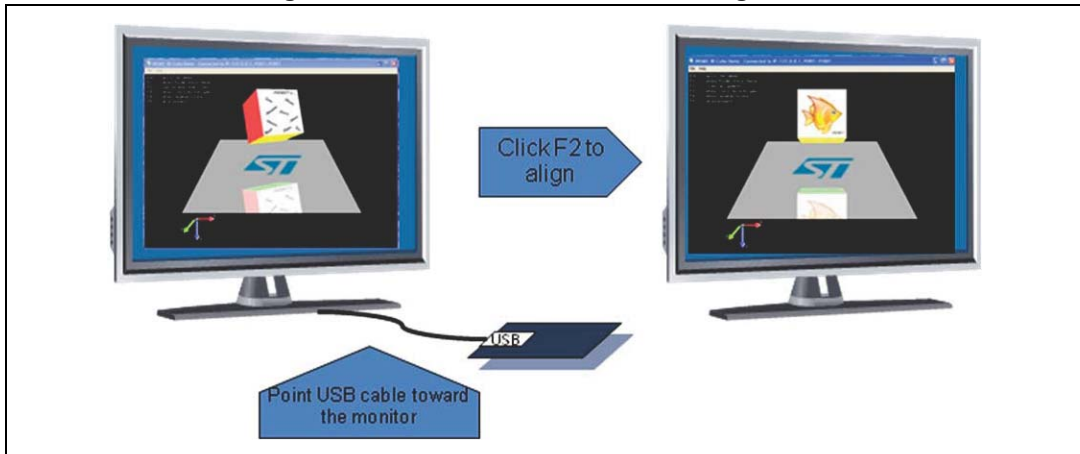

### 3.1.8 Compass demo

The iNEMO suite also includes the Compass demo (*Figure 21*) developed using the accelerometer and magnetometer sensor. To run the demo, check “Compass” in the sensor settings window (see *3.1.3: Acquisition settings, Figure 17*), press the compass icon and start the acquisition from the GUI toolbar (*Figure 17*).

Figure 21. Compass demo

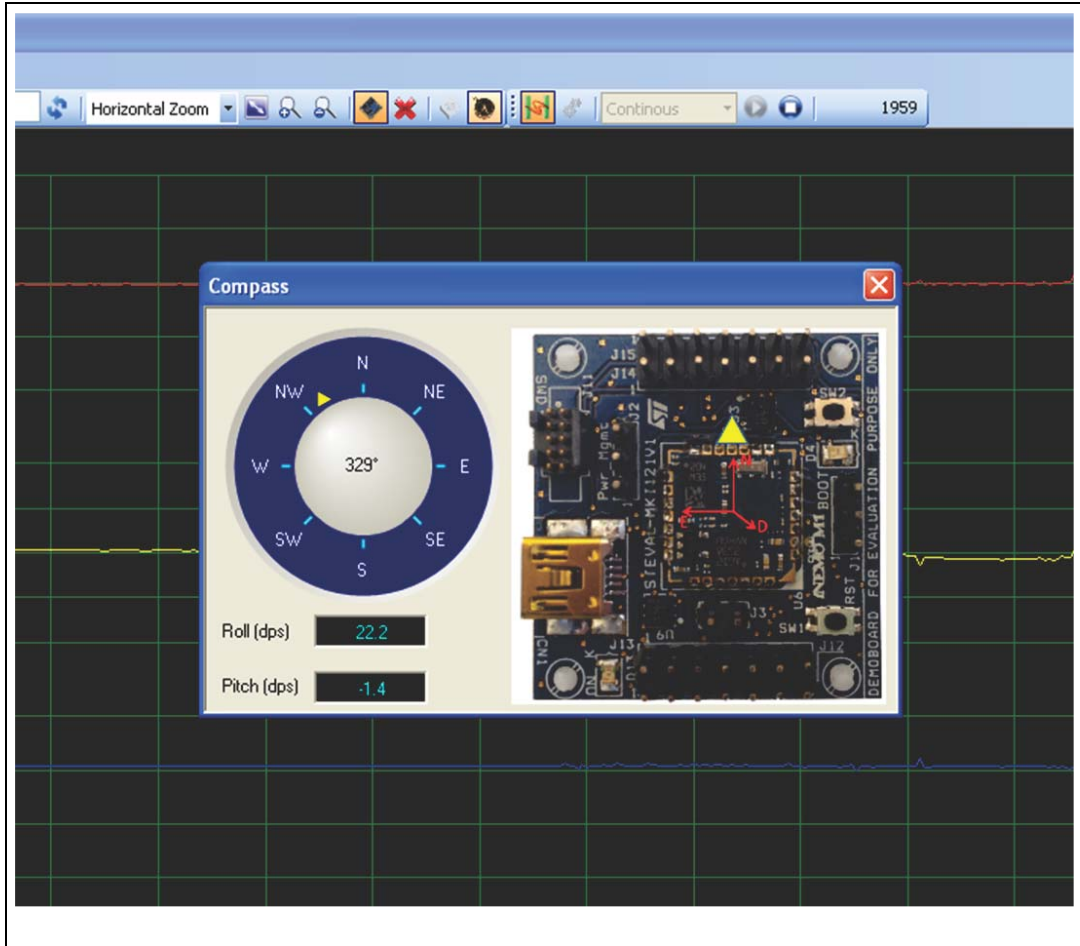

The heading of the board is indicated by the yellow arrow according to the NED system as shown in *Figure 21*. The “Compass” window also shows information on roll and pitch values.

The demo is a tilt-Compass including the hard iron calibration. HIC (hard iron calibration) corrects the errors resulting from external magnetic influences that can affect the accuracy of the heading readings. To enable the HIC, click on the “Start HIC” button in the “Sensor Settings Magnetometer” window and follow the instructions.

# Appendix A Schematics

Figure 22. Reset, pushbutton, boot, user LED

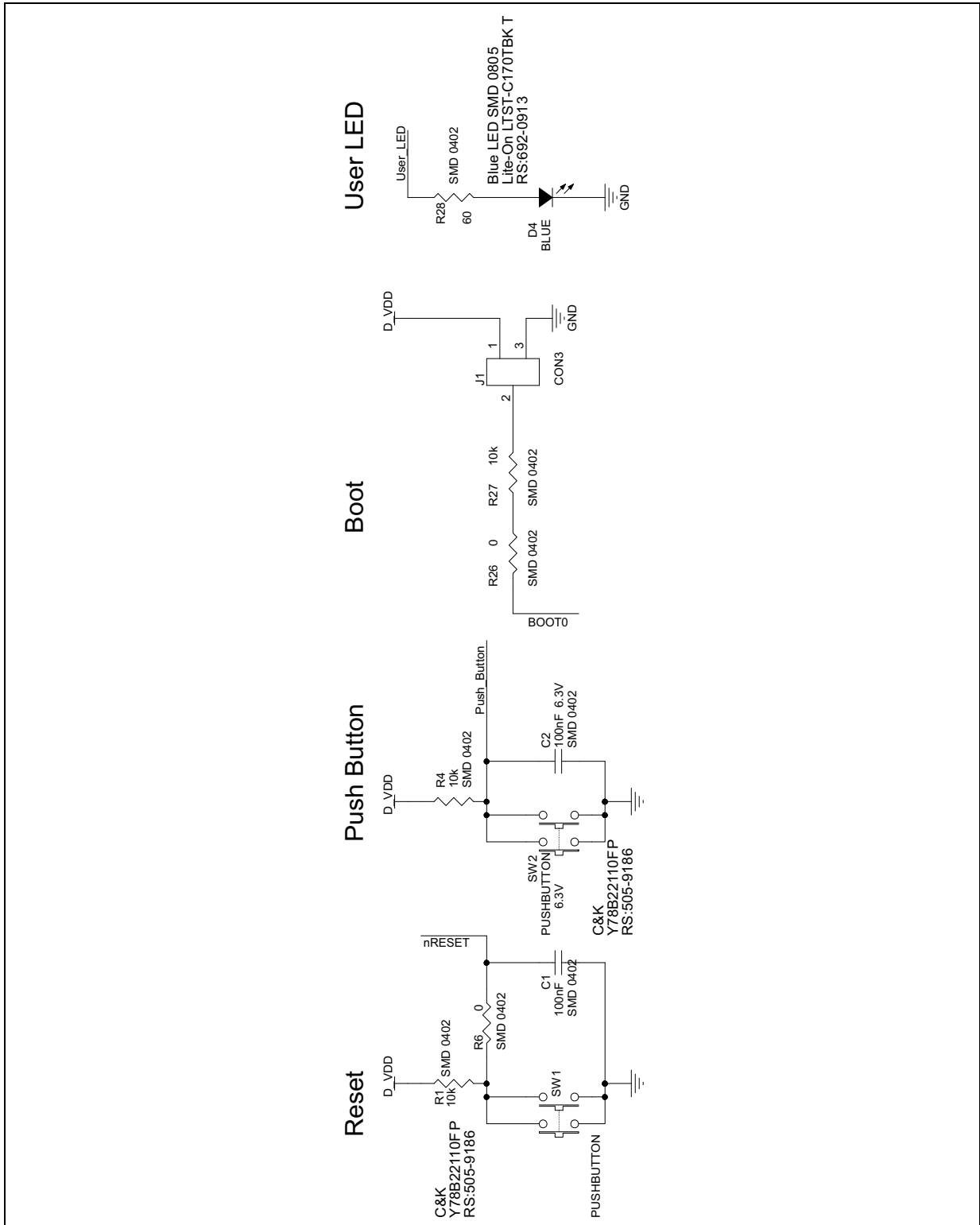

Figure 23. USB

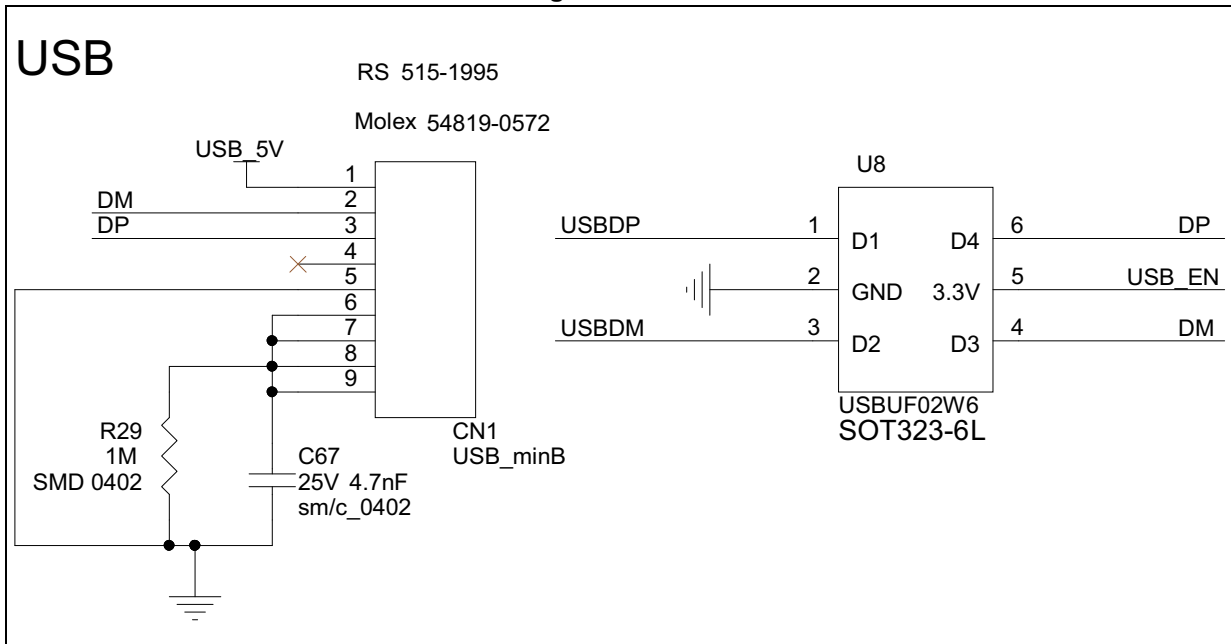

Figure 24. INEMO-M1 SoB

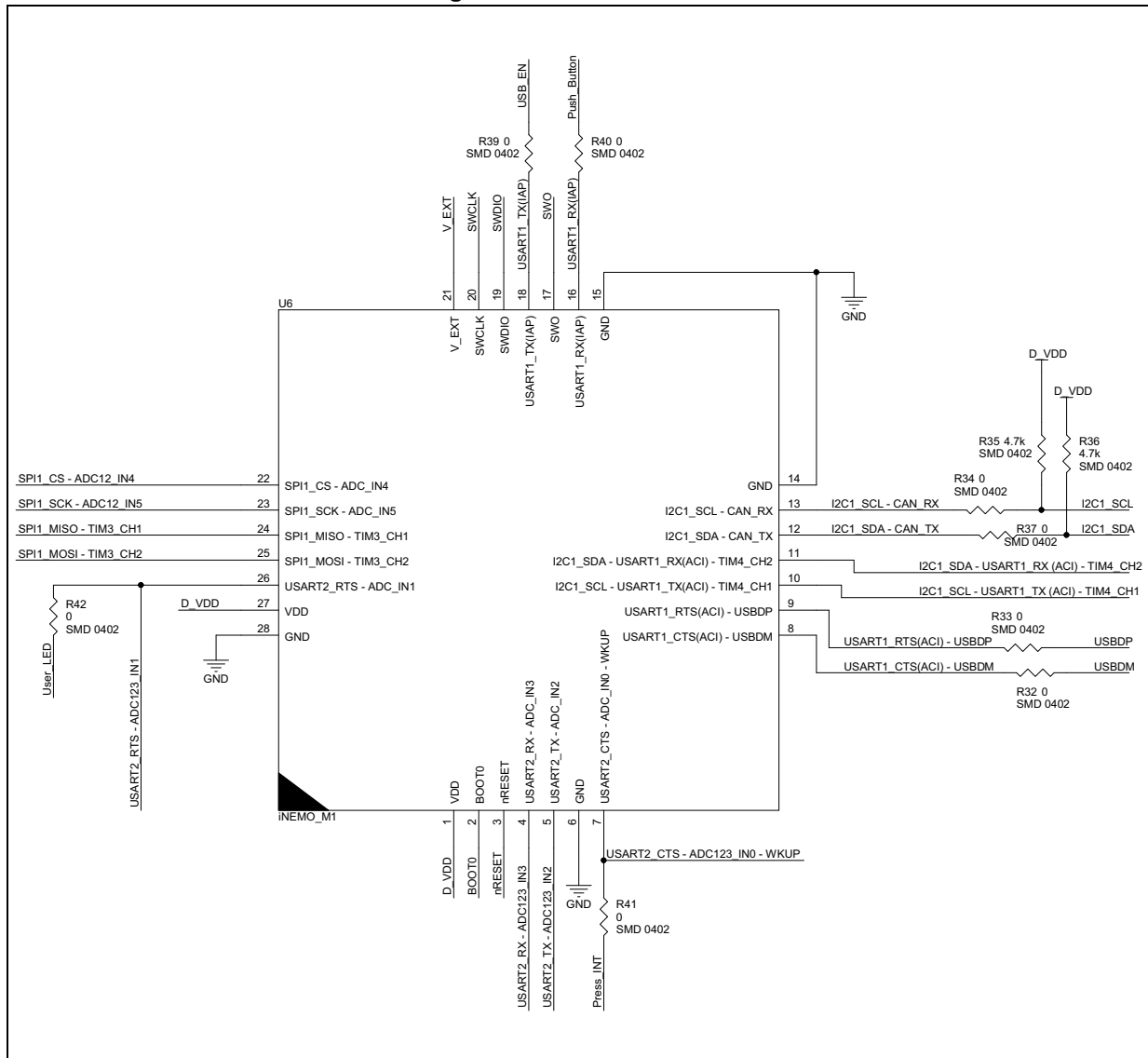

Figure 25. Pressure sensor

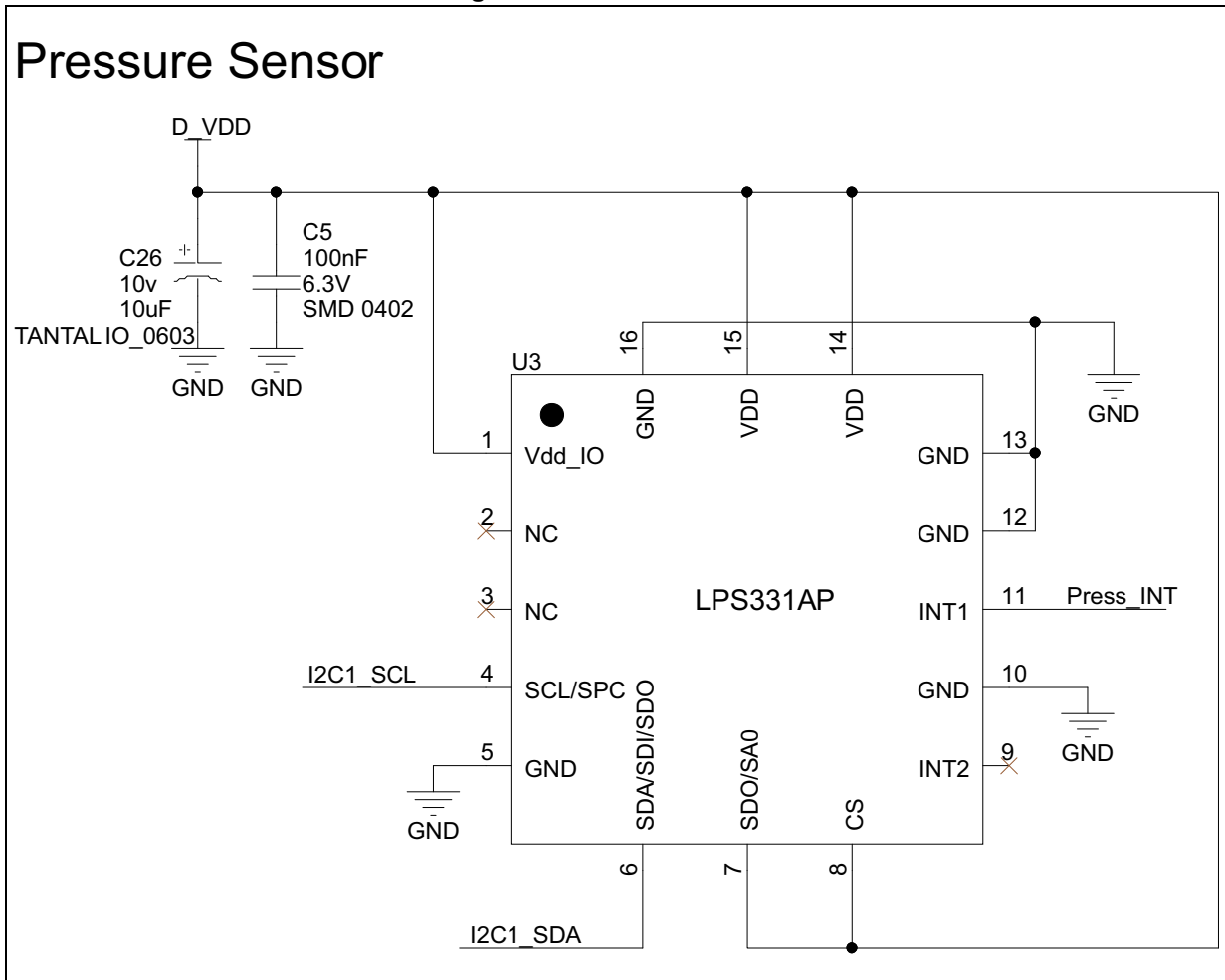

Figure 26. Power management stage

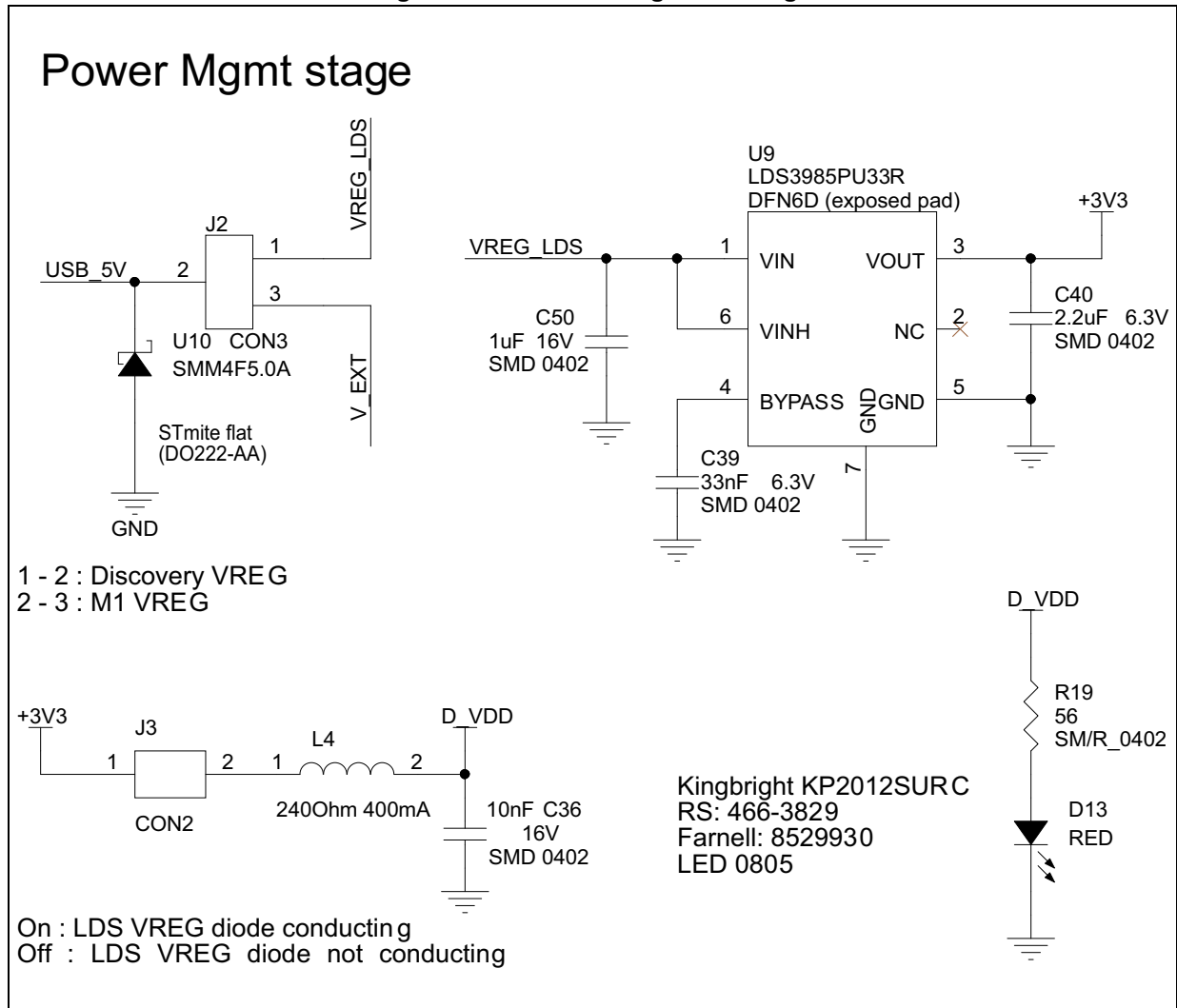



Figure 27. SWD

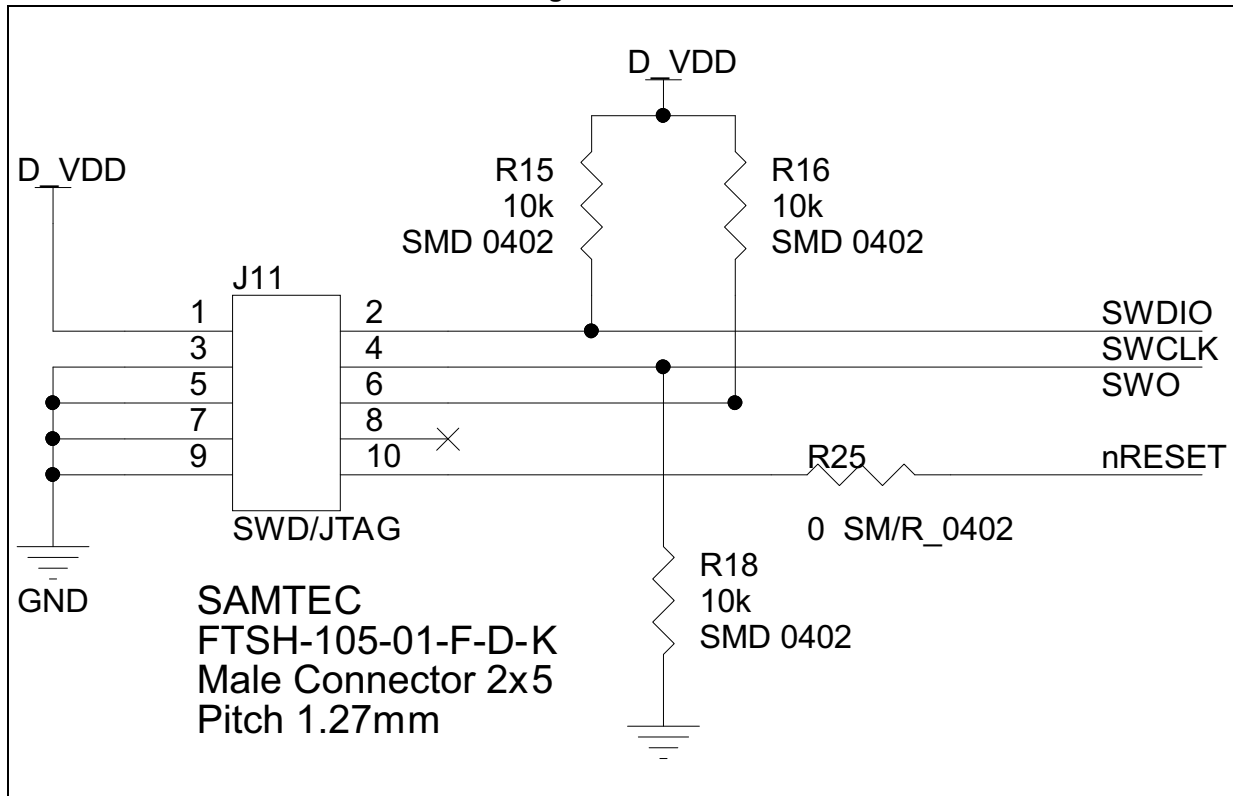
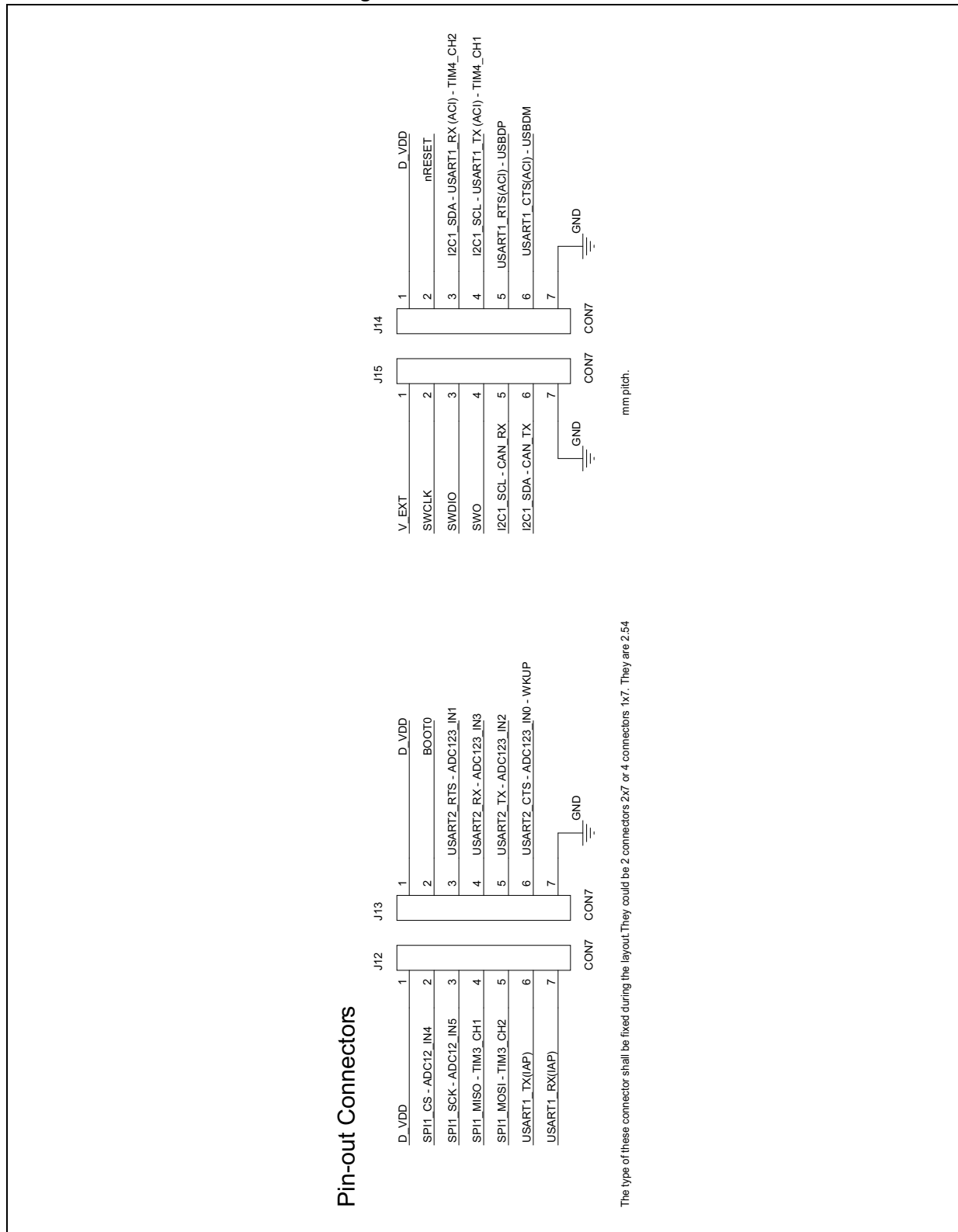

Figure 28. Pinout connectors



The type of these connector shall be fixed during the layout. They could be 2 connectors 2x7 or 4 connectors 1x7. They are 2,54

## 4 Revision history

**Table 5. Document revision history**

Date	Revision	Changes
24-May-2013	1	Initial release.

**Please Read Carefully:**

Information in this document is provided solely in connection with ST products. STMicroelectronics NV and its subsidiaries ("ST") reserve the right to make changes, corrections, modifications or improvements, to this document, and the products and services described herein at any time, without notice.

All ST products are sold pursuant to ST's terms and conditions of sale.

Purchasers are solely responsible for the choice, selection and use of the ST products and services described herein, and ST assumes no liability whatsoever relating to the choice, selection or use of the ST products and services described herein.

No license, express or implied, by estoppel or otherwise, to any intellectual property rights is granted under this document. If any part of this document refers to any third party products or services it shall not be deemed a license grant by ST for the use of such third party products or services, or any intellectual property contained therein or considered as a warranty covering the use in any manner whatsoever of such third party products or services or any intellectual property contained therein.

**UNLESS OTHERWISE SET FORTH IN ST'S TERMS AND CONDITIONS OF SALE ST DISCLAIMS ANY EXPRESS OR IMPLIED WARRANTY WITH RESPECT TO THE USE AND/OR SALE OF ST PRODUCTS INCLUDING WITHOUT LIMITATION IMPLIED WARRANTIES OF MERCHANTABILITY, FITNESS FOR A PARTICULAR PURPOSE (AND THEIR EQUIVALENTS UNDER THE LAWS OF ANY JURISDICTION), OR INFRINGEMENT OF ANY PATENT, COPYRIGHT OR OTHER INTELLECTUAL PROPERTY RIGHT.**

**ST PRODUCTS ARE NOT AUTHORIZED FOR USE IN WEAPONS. NOR ARE ST PRODUCTS DESIGNED OR AUTHORIZED FOR USE IN: (A) SAFETY CRITICAL APPLICATIONS SUCH AS LIFE SUPPORTING, ACTIVE IMPLANTED DEVICES OR SYSTEMS WITH PRODUCT FUNCTIONAL SAFETY REQUIREMENTS; (B) AERONAUTIC APPLICATIONS; (C) AUTOMOTIVE APPLICATIONS OR ENVIRONMENTS, AND/OR (D) AEROSPACE APPLICATIONS OR ENVIRONMENTS. WHERE ST PRODUCTS ARE NOT DESIGNED FOR SUCH USE, THE PURCHASER SHALL USE PRODUCTS AT PURCHASER'S SOLE RISK, EVEN IF ST HAS BEEN INFORMED IN WRITING OF SUCH USAGE, UNLESS A PRODUCT IS EXPRESSLY DESIGNATED BY ST AS BEING INTENDED FOR "AUTOMOTIVE, AUTOMOTIVE SAFETY OR MEDICAL" INDUSTRY DOMAINS ACCORDING TO ST PRODUCT DESIGN SPECIFICATIONS. PRODUCTS FORMALLY ESCC, QML OR JAN QUALIFIED ARE DEEMED SUITABLE FOR USE IN AEROSPACE BY THE CORRESPONDING GOVERNMENTAL AGENCY.**

Resale of ST products with provisions different from the statements and/or technical features set forth in this document shall immediately void any warranty granted by ST for the ST product or service described herein and shall not create or extend in any manner whatsoever, any liability of ST.

ST and the ST logo are trademarks or registered trademarks of ST in various countries.

Information in this document supersedes and replaces all information previously supplied.

The ST logo is a registered trademark of STMicroelectronics. All other names are the property of their respective owners.

© 2013 STMicroelectronics - All rights reserved

STMicroelectronics group of companies

Australia - Belgium - Brazil - Canada - China - Czech Republic - Finland - France - Germany - Hong Kong - India - Israel - Italy - Japan - Malaysia - Malta - Morocco - Philippines - Singapore - Spain - Sweden - Switzerland - United Kingdom - United States of America

[www.st.com](http://www.st.com)

# Mouser Electronics

Authorized Distributor

Click to View Pricing, Inventory, Delivery & Lifecycle Information:

[STMicroelectronics:](#)

[STEVAL-MKI121V1](#)