

Service Guide

Grease pump Kit

Description

The Champion product grease kit is a manually operated, spring powered grease kit that comes complete with a hand piece. It is designed to fit a 2.5kg grease pail. The hand piece for the product, once loaded, is capable of approximately 30 high pressure shots before needing to be reprimed. The high pressure/high volume option facilitates quick and easy greasing with grease pressures of 10,000psi and dispensing quantities of up to 1.25 grams per stroke possible. Suitable for use with greases up to NLGI2, the light weight, rugged and portable unit makes light work of arduous greasing applications. The Champion product is the ideal greasing tool for people looking to minimize the time and effort required to grease their vehicles or machinery.

Specifications

Uses	Light and self collapsing grease
Discharge Quantity	Once loaded, approximately 30 shots – up to 1.25 grams of grease per shot
Size	2.5kg grease pails
Pressures	Up to 10,000psi

Important Please Note

Our Champion product 2.5kg grease kit is designed for use with most greases, however, trouble free greasing is assured with the use of greases up to No. 2 consistency. That is, the kit is recommended for use with light and self collapsing greases.

Preparing Your Champion 2.5kg Grease Kit

- 1 Remove follower plate from the pump tube.
- 2 Insert follower plate into the grease container as shown with boss facing upwards. Push down firmly onto the grease until grease emerges through the boss.
- 3 Push the pump tube through the boss and down until the drum cover sits firmly on rim of grease container. Hand tighten the 3 thumbscrews evenly under rim of the container.
- 4 To achieve initial prime, push rod cap down several times by using your hand or foot to start grease flowing through the grease hose. When the hose is full of grease, the rod cap will stay down.
- 5 Squeeze gun handle and hold handle closed to bleed air out of the system. When fully bled, grease from out of the 2.5kg drum will appear at the coupler.

Note: Grease must travel through entire length of hose to accomplish full bleeding and it may be necessary to repeat Step 4 a couple of times. If unit fails to prime, bump container base several times on a solid surface to settle the grease.

Important Please Note

Your Champion product 2.5kg grease kit is now ready for operation.

While greasing, the rod cap will rise slowly. When it is fully up and the hand piece loses pressure, push the rod cap down once or twice to reprime the system and to enable you to continue greasing. Each pump prime will provide sufficient grease for up to 30 grease shots. The hand piece is normally operated on the hi-volume switch position. Should high pressure be required to help clear a blocked or seized lube point, simply move the button on the hi-pressure position.



Changing over 2.5kg grease drums

- 1 Unscrew the 3 thumbscrews.
- 2 Remove the Champion product from the container.
- 3 Remove follower plate from the empty 2.5kg grease drum and repeat preparation steps 2, 3 and 4

Before operating your product 2.5kg grease kit, bleed any trapped air from the unit.

To remove trapped air: (Point gun in direction of an empty receptacle)

- 1 Push pump plunger down a few times to start the grease flowing through the grease hose.
- 2 Squeeze and hold gun handle in to automatically remove trapped air –repeat 1 and 2 until all air is removed.

How to clean the strainer

Should the strainer need cleaning, (refer trouble shooting guide, page 3, item C(b)), undo the nut at the base of the pump spring with a suitable spanner, remove assembly, lever off strainer cover and clean the appropriate parts as illustrated.

Parts and Drawing Breakdown For the Pump Kit

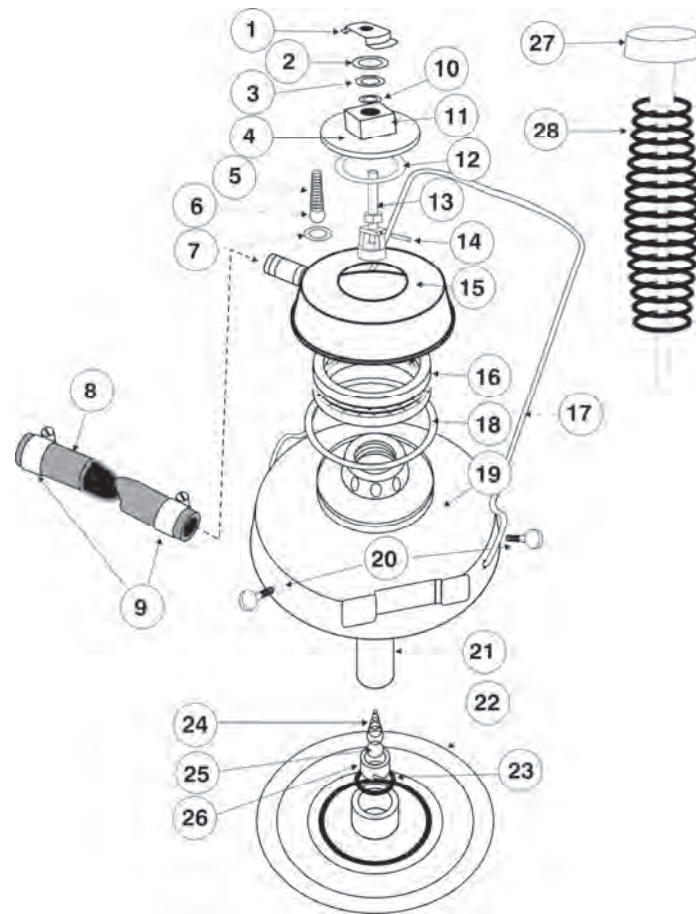

Parts List

ITEM	DESCRIPTION
1	Retainer Cap
2	Washer
3	Back up washer
4	Clamp nut
5	Ball spring
6	1/2" Ball
7	O'Ring
8	Hose
9	Hose Clamp
10	O'Ring
11	Clamp Nut
12	Sealing Washer
13	Piston Rod and Cup Assembly
14	Spirol Pin
15	Strainer Cover
16	Strainer
17	Handle
18	O'Ring
19	Lid Base
20	Thump Screw
21	Pump Tube
22	Follower
23	O'Ring
24	Ball Retainer
25	9/16" Ball
26	Footvalve
27	Piston Rod and Cap Assembly
28	Pump Spring

Trouble Shooting For the pump Kit of the product

PROBLEM	CAUSE	SOLUTION
Rod cap rises slowly when the hand piece is not in use (no visible external leakages)	(a) dirt trapped between inlet ball (26) and piston (b) piston O'Ring (25) defective or worn	(a) unscrew clamp nut (7) and withdraw assembly. Clean ball (26) and piston (10) thoroughly. Reassemble (b) replace piston O'Ring .
Rod cap springs up and the unit will not pump grease	(a) air lock in grease caused by dent in container stops follower damaged O'Ring (21) in follower (20) (b) grease container empty (c) footvalve assy (19) faulty, holding ball (18) off seat	(a) remove dents or tilt follower plate (20) under dent. Replace O'Ring (21) in follower plate (20). Change over to new container or refill with grease. Replace with new assy 17-18-19 do not attempt to rework this part.
Rod cap stays down. The 2.5kg grease kit will not pump grease	(a) grade of grease too heavy (b) strainer blocked	(a) Use No. 2 grade of grease, or lighter. Force out old grease. (b) Unscrew clamp nut (7) and withdraw assembly. Using a screwdriver, lever off the strainer cover (11). Clean or replace the strainer (13). see general instructions below for cleaning technique.
Grease leaks at top of clamp nut (7)	Gland O'Ring (96) and back up washer (5) are defective or worn	Unscrew clamp nut (7) and withdraw assembly. Hold piston (10) and loosen the nut (27). Remove the pin (9) and withdraw the piston (10). Ease spring tension on the nut (27) by pushing against spring (92) on clamp nut (7) and carefully undo nut (27). Replace O'Ring (96) and back up washer (5). Order (5). When re-assembling support piston (10) when driving pin (9) home, please ensure that the flat end of spring (2) fits in the cap (1).
Grease leaks at bottom of strainer cover (11)	(a) O'Ring (14) damaged (b) Spot welds broken	(a) Unscrew clamp nut (7) and withdraw assembly. Using screwdriver, lever off strainer cover (11) replace O'Ring Order (14) (b) Replace drum cover base (15).
Grease leaks from under clamp nut (7)	(a) Dirt under clamp nut (7) (b) Damaged seal washer (8)	(a) Undo and clean surfaces (b) Replace seal washer. Order (8).

Parts and Drawing Breakdown For the Pump Hand piece

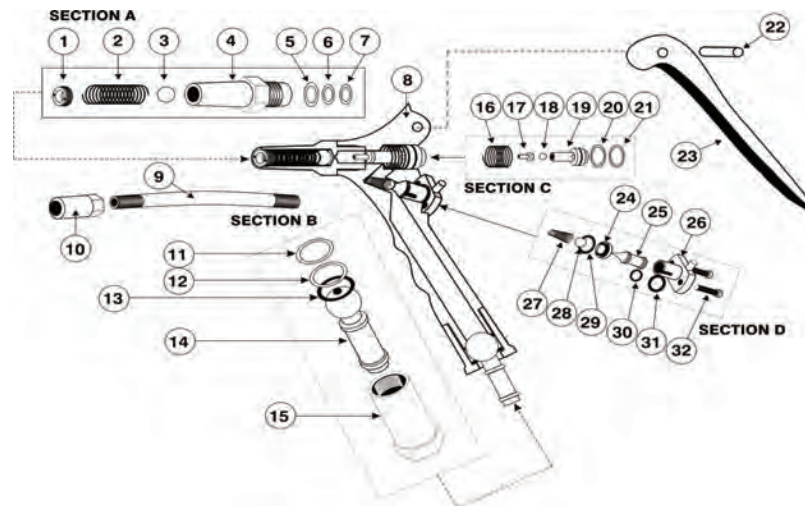

Parts List – The hand piece

ITEM	DESCRIPTION	QTY		
1	Outlet Screw	1		
2	Outlet Spring	1		
3	Outlet Ball	1		
4	Outlet Body	1		
5	Teflon Back Up Washer	1		
6	Glyd Ring	1		
7	Piston O-ring	1		
8	Hand piece Casting	1		
9	Rigid Extension	1		
10	Grease Coupler	1		
11	Retainer O-ring	1		
12	Hose Adaptor Washer	1		
13	Hose Adaptor O-ring	1		
14	Hose Adaptor Ball End	1		
15	Ball Socket Retainer	1		
16	Inlet Check Spring	1		
17	Valve Stem Piston	1		
18	Piston Ball	1		
19	Piston	1		
20	Glyd Ring	1		
21	Seal Body O-ring	1		
22	Handle Pin	1		
23	Handle	1		
24	Valve Inlet Seat	1		
25	Operating Plunger Control	1		
26	Control Body Assembly	1		
27	Inlet Spring	1		
28	Inlet Ball	1		
29	Seal Body O-ring	1		
30	Plunger Control O-ring	1		
31	Seal Body O-ring	1		
32	Cap Socket	2		

Trouble shooting for the product Hand Piece

PROBLEM	CAUSE	SOLUTION
The 2.5kg grease kit coupler leaks	<p>(a) There is dirt under the seat of the outer ball (3)</p> <p>(b) The valve stem (17), has worked itself loose and is holding the outlet ball (3), off its seat.</p>	<p>(a) Set the hand piece to the high volume setting and strike handle sharply. If the coupler still leaks, remove the rigid extension (9), spring keeper screw (21), spring (22) and outer ball (23). Clear the seat and partly replace the ball, screw and spring keeper screw. Prime the pump completely to ensure the maximum possible supply of grease to the hand piece and tighten up the spring keeper screw until the grease begins to stop leaking. Then tighten the spring keeper in an extra two full turns. Finally, reassemble the rigid extension to the hand piece.</p> <p>IMPORTANT: Please note that if you tighten up the spring keeper screw too much, the hand piece will become difficult to operate. Too few turns will allow the hand piece to leak. If the coupler still leaks, replace the outlet body (4). When refitting the outlet body to the handle, ensure that the handle is held in the closed position. Doing so enables the back up washers (5 & 7) and o’ring seals to seat squarely on to the piston (19).</p> <p>(b) Remove the handle (23) by withdrawing the handle pin (22). Remove the piston (19), retighten the valve stem (17) or replace with spare part.</p>
Hand piece leaks at the back end of the piston	The glyd ring (20) is worn	<p>Remove handle (22) by withdrawing handle pin (22). Remove the piston (19) and replace with the spare part.</p> <p>IMPORTANT: If any signs of wear are visible on the piston, replace with the spare part will also be required to solve this problem.</p>
The hand piece fails to deliver grease when on the high pressure setting	<p>(a) There is dirt under the delivery ball (18) or there is a damaged ball seat in the piston (19)</p> <p>(b) Seals are worn (25), (26) and (27).</p> <p>(c) Valve inlet stem (17) has become loose or dislodged from the piston (19).</p>	<p>(a) Change the setting to “high volume” and hit the handle (23) hard to shift the dirt off the seat. If leaks are still occurring, remove the handle (23) by withdrawing handle pin (22), spring (16) and ball (18). Clean the ball and seat if the problem continues, order and install spare part .</p> <p>(b) Use spare part and (b) Use spare part and replace seals in the following order – washer (5), O’ring (6) and washer (7).</p> <p>(c) Refer to the 2.5kg grease kits coupler leaks section to referencing section (b).</p>

PROBLEM	CAUSE	SOLUTION
The hand piece fails to deliver grease when on the high volume setting	(a) There is dirt on the valve inlet seat (24). (b) Operating plunger control (25) sticking in control body assembly (26).	(a) IMPORTANT: This problem will result in a decreased volume of grease being dispensed per shot. Remove control body (26) and tap out valve inlet seat (24), O' Ring (31), ball (30) and spring (27). Clean the ball and seat and replace in the following order – spring, ball, O'Ring, valve seal and control body. (b) Replace the control body assembly (26).
Control push rod in the control body leaks	O'Ring (31) is worn	Remove control body assembly (26) from the hand piece. Also remove the operating control plunger (25) from the control body and replace with spare part kit.
Hand piece leaks at the grease swivel	Worn seals (11) & (12)	Unscrew ball socket retainer (15), push the seals out and use spare part kit . Be careful to replace the components in the following order – O'Ring (13) and washer (12). Locate O'Ring (11) on to the hand piece casting (8). Reassemble ball
When on the high volume setting, the hand piece is too slow and too hard to operate	(a) Spring (16) may have weakened or collapsed and are blocking the flow of grease (b) The grade of grease being used is too heavy. (c) Too much compression on the outlet spring (2).	(a) Replace spring (16) and use spare part kit and valve stem spare part kit. (b) Change to an NLGI2 or lower viscosity grease. (c) Reset the spring keeper screw as noted in the 2.5kg grease kits coupler leaks section. If the problem persists, you will need to replace the outlet body assembly.

GENERAL INSTRUCTIONS

ALWAYS When the gun has been serviced and the trouble found to be caused by dirt in the valves, the pump unit should also be cleaned out thoroughly to eliminate the dirt at its source.

CLEANLINESS Dirt and foreign matter (lint, etc.) can seriously affect operation and machinery. Dismantling and reassembly of this unit should only be attempted in clean conditions.